



**AD-115ES**  
**Parts Manual**  
24 VAC Phase 7 / S.A.F.E. System  
July 2002

---

**American Dryer Corporation**  
88 Currant Road  
Fall River, MA 02720-4781  
Telephone: (508) 678-9000 / Fax: (508) 678-9447  
E-mail: techsupport@amdry.com

[www.amdry.com](http://www.amdry.com)

# Retain This Manual In A Safe Place For Future Reference

American Dryer Corporation products embody advanced concepts in engineering, design, and safety. If this product is properly maintained, it will provide many years of safe, efficient, and trouble free operation.

**ONLY qualified technicians should service this equipment.**

**OBSERVE ALL SAFETY PRECAUTIONS** displayed on the equipment or specified in the installation manual included with the dryer.

The following “**FOR YOUR SAFETY**” caution must be posted near the dryer in a prominent location.

## FOR YOUR SAFETY

Do not store or use gasoline or other flammable vapors and liquids in the vicinity of this or any other appliance.

## POUR VOTRE SÉCURITÉ

Ne pas entreposer ni utiliser d'essence ni d'autres vapeurs ou liquides inflammables à proximité de cet appareil ou de tout autre appareil.

We have tried to make this manual as complete as possible and hope you will find it useful. ADC reserves the right to make changes from time to time, without notice or obligation, in prices, specifications, colors, and material, and to change or discontinue models.

## Important

For your convenience, log the following information:

DATE OF PURCHASE \_\_\_\_\_ MODEL NO. AD-115ES  
RESELLER'S NAME \_\_\_\_\_  
Serial Number(s) \_\_\_\_\_  
\_\_\_\_\_  
\_\_\_\_\_

Replacement parts can be obtained from your reseller or the ADC factory. When ordering replacement parts from the factory, you can FAX your order to ADC at (508) 678-9447 or telephone your order directly to the ADC Parts Department at (508) 678-9000. Please specify the dryer model number and serial number in addition to the description and part number, so that your order is processed accurately and promptly.

The illustrations on the following pages may not depict your particular dryer exactly. The illustrations are a composite of the various dryer models. Be sure to check the descriptions of the parts thoroughly before ordering.

### **“IMPORTANT NOTE TO PURCHASER”**

Information must be obtained from your local gas supplier on the instructions to be followed if the user smells gas. These instructions must be posted in a prominent location near the dryer.

# Table of Contents

Control Door Assembly .....	4
Phase 7 Non-Coin Microprocessor Control Panel Assembly .....	5
Dual Timer "Tap Touch" Controls .....	6
Control Box Assembly .....	7
Dual Timer Control Box Assembly .....	8
Lint Drawer / Lint Drawer Switch Box Assemblies for Models Mfd. as of April 12, 2003 .....	9
Lint Drawer / Lint Drawer Switch Box Assemblies for Models Mfd. prior to April 12, 2003 .....	10
Drop Lint Door Assembly .....	11
Front Panel Main Door Assembly .....	12
Microprocessor Temperature Sensor Bracket Assembly .....	14
Non-Microprocessor Temperature Sensor Bracket Assembly .....	15
Tumbler / Support Assemblies .....	16
Tumbler Bearing Mount Assembly .....	17
Idler Bearing Mount Assembly .....	18
T.E.F.C. Tumbler Motor Mount Assembly .....	20
Blower Motor Mount Assembly .....	21
Direct Spark Ignition Burner Assembly .....	22
Sail Switch Assembly .....	24
60 kW 208-240 Volt Electric Oven Assembly .....	26
60 kW 380-416 / 480 Volt Electric Oven Assembly .....	28
72 kW 208-240 Volt Electric Oven Assembly .....	30
72 kW 380-416 / 480 Volt Electric Oven Assembly .....	32
208-240 Volt Oven Relay Box Assembly .....	34
380-480 Volt Oven Relay Box Assembly .....	35
Steam Damper Assembly .....	36
Phase 7 Reversing Relay Panel Assembly .....	37
Dual Timer Reversing Relay Mounting Panel Assembly .....	38
Back Guard Assembly .....	39
Fire Suppression System Solenoid Assembly for Models Mfd. as of September 23, 2004 .....	40
Fire Suppression System Solenoid Assembly for Models Mfd. prior to September 23, 2004 .....	41
S.A.F.E. Temperature Probe Assembly .....	42
Additional Parts Available .....	43

# Control Door Assembly

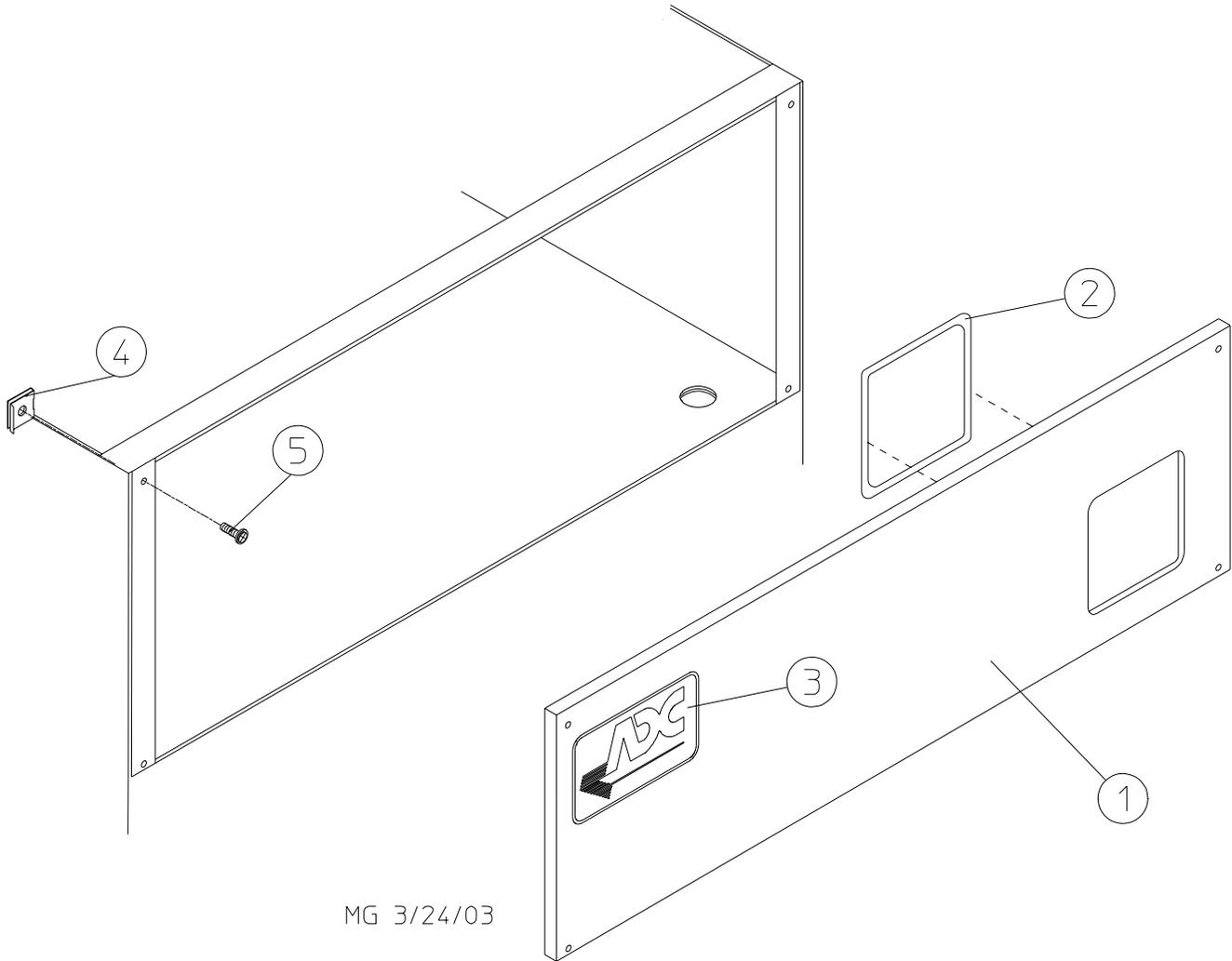

MG 3/24/03

MAN6586

Illus. No.	Part No.	Qty.	Description
1	825339*	1	Control Door Assembly (for gas models and electric models Only)
	825365*	1	Short Control Door (for steam models Only)
2	117604	3	Noise Suppression Tape (sold by the foot)
3	112360	1	ADC Logo
	870011	1	Logo Double-Sided Tape Kit
4	154011	4	Multi-Thread U-Nut
5	150321	4	#10-32 x 1/2" Phillips Head Machine Screw

\* Specify color when ordering.

# Phase 7 Non-Coin Microprocessor Control Panel Assembly

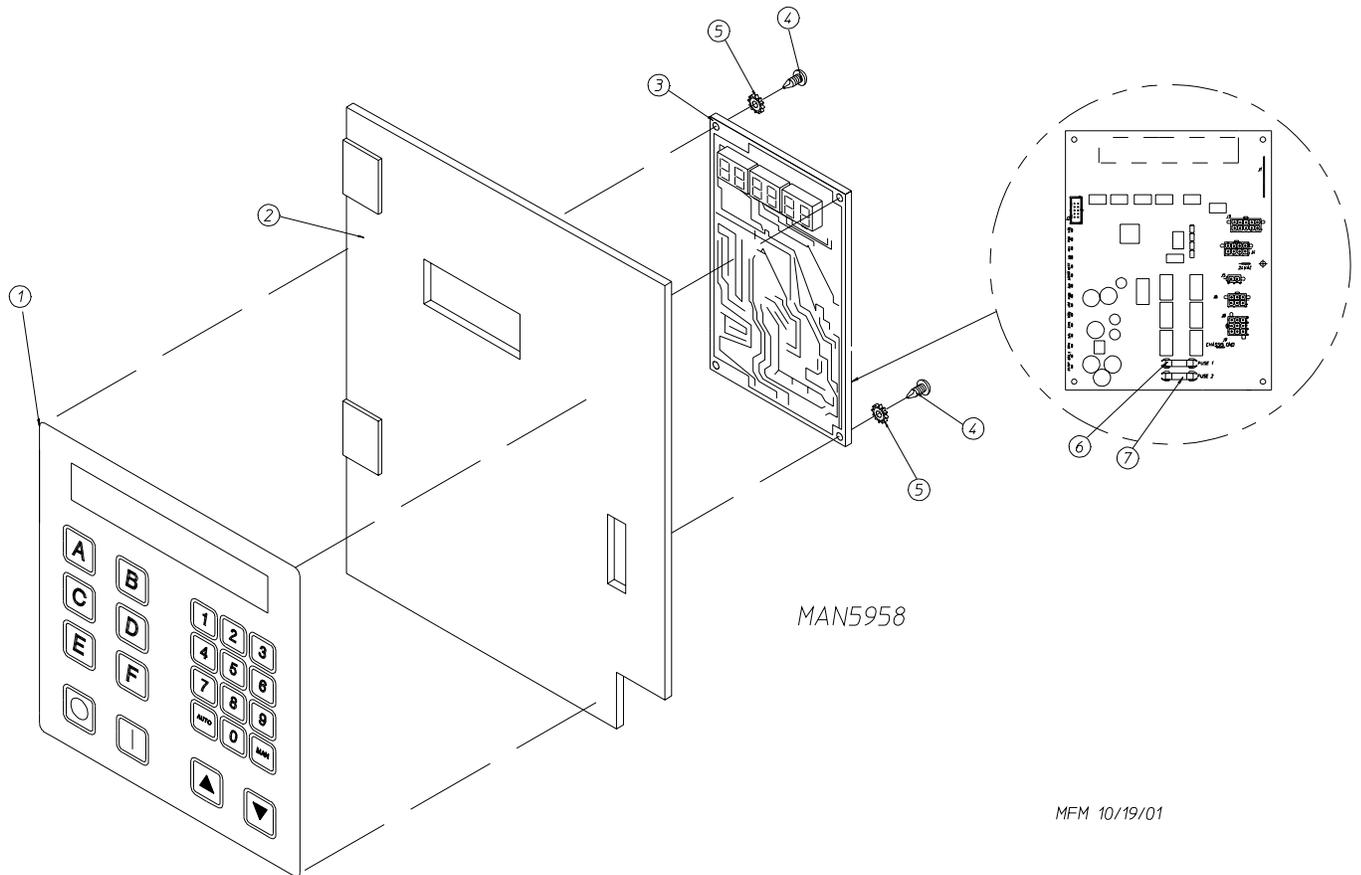

Illus. No.	Part No.	Qty.	Description
1	112577	1	Phase 7 Non-Coin Keypad
2	850979	1	Phase 7 Microprocessor Controller (computer) Panel ONLY
3	887003	1	Phase 7 Microprocessor Controller with S.A.F.E. System (for models mfd. as of December 1, 2003)
	887000	1	Phase 7 Microprocessor Controller with S.A.F.E. System (for models mfd. prior to December 1, 2003)
	887024	1	Phase 7 Microprocessor Controller without Fire Suppression System
4	150005	4	#6-32 x 3/4" Phillips Round Head Machine Screw
5	153010	4	#6 Star Washer
6	136097	1	500-mA Fuse
7	136016	1	5-amp Fuse

# Dual Timer "Tap Touch" Controls

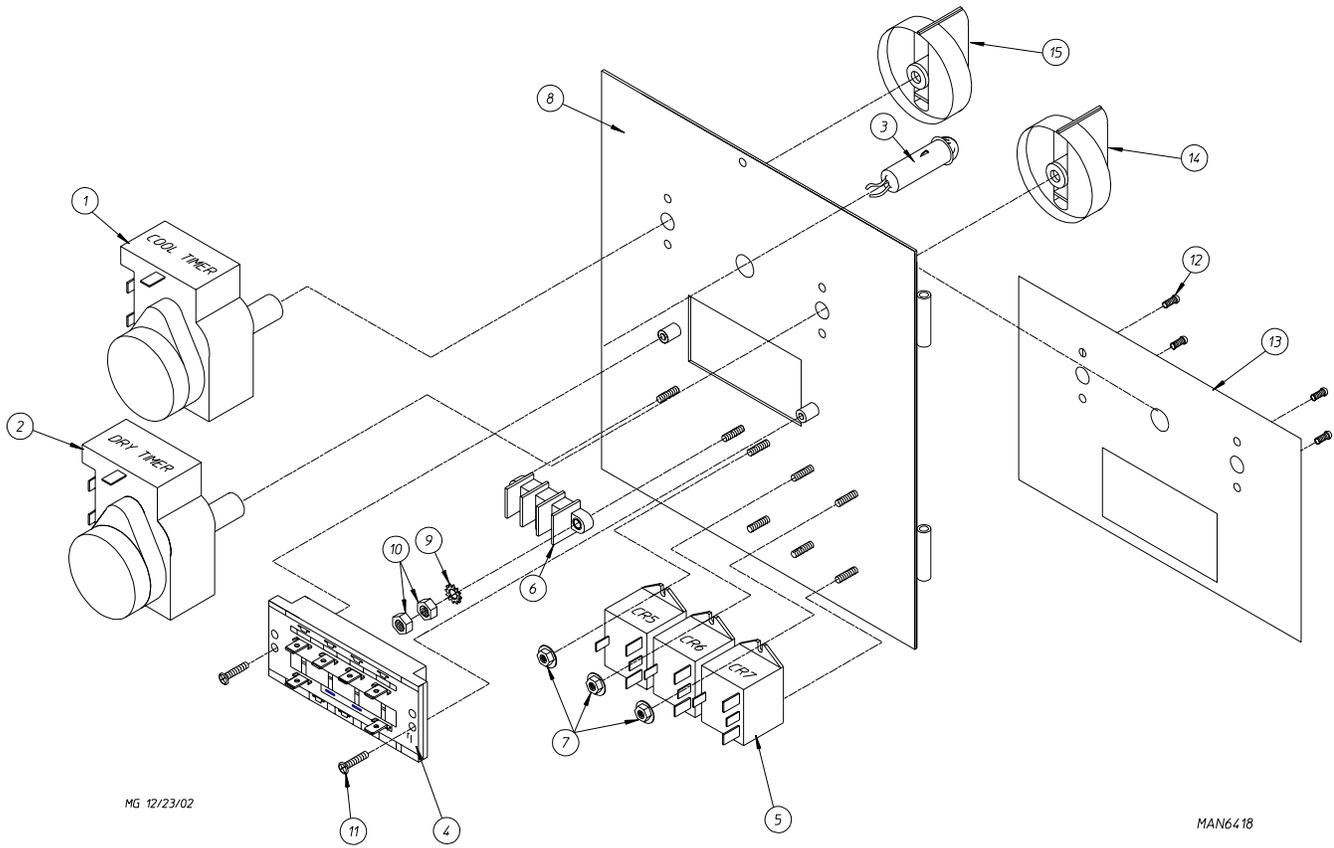

MG 12/23/02

MAN6418

<u>Illus. No.</u>	<u>Part No.</u>	<u>Qty.</u>	<u>Description</u>
1	124030	1	15 Minute Timer – 24 VAC
2	124025	1	60 Minute Timer – 24 VAC
3	824175	1	Red Pilot Light – 24 VAC
4	122301	1	"Tap Touch" Switch
5	131932	3	Relay SPST 24V
6	120708	1	Terminal Closed Block
7	151000	6	#6-32 Pal Nut
8	824296	1	Dual Timer Panel Complete Assembly (includes illus. nos. 1 through 15)
	824067	1	Dual Timer Panel ONLY
9	153010	2	#6 Star Washer
10	152000	2	#6-32 Hex Nut
11	150207	2	#10-24 x 1/2" Phillips Pan Head Machine Screw
12	150110	4	#8-32 x 1/4" Phillips Round Head Machine Screw
13	112563	1	Dual Timer Panel Overlay
14	124104	1	Pure Touch Knob with Red Pointer
15	124105	1	Pure Touch Knob with Blue Pointer

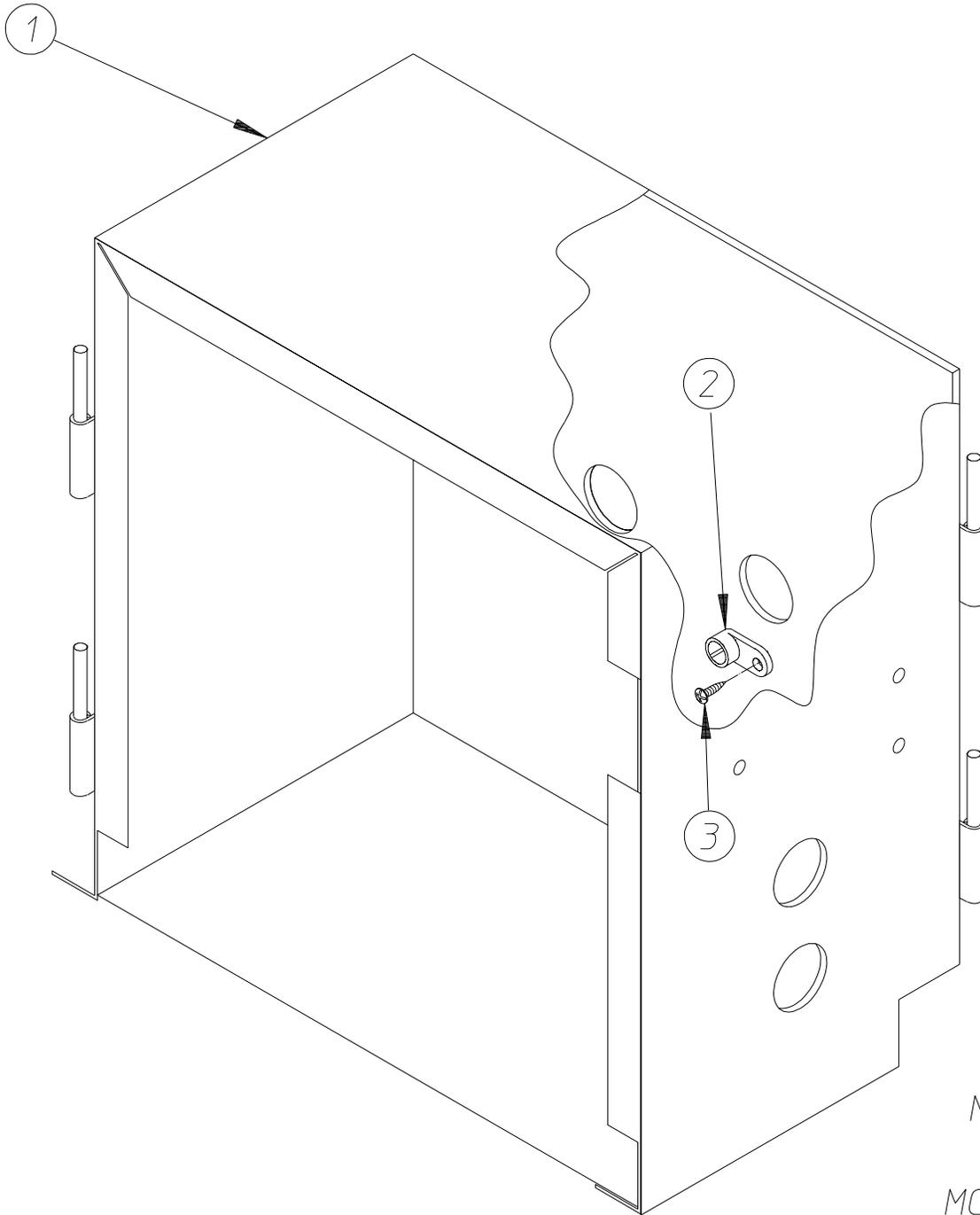

<u>Illus. No.</u>	<u>Part No.</u>	<u>Qty.</u>	<u>Description</u>
1	853122	1	Electric Box
2	121010	1	L-70 Ground Lug
3	150309	1	#10-16 x 1/2" Hex Head TEK Crimpite Screw

# Dual Timer Control Box Assembly

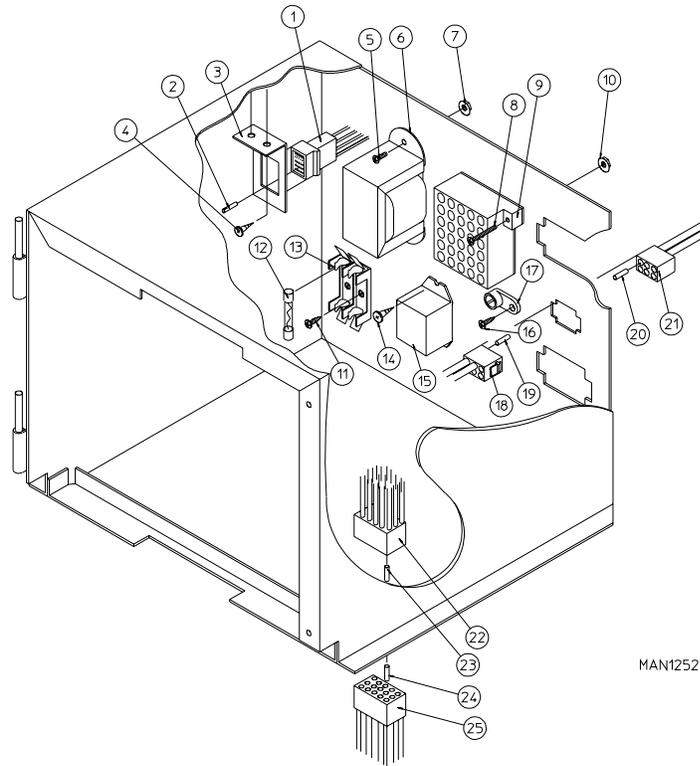

Illus. No.	Part No.	Qty.	Description
1	122603	1	9-Pin Socket Connector
2	122701	7	Socket Terminal
	122801	1	Pin / Socket Extraction Tool
3	315010	1	9-Pin Connector Bracket
4	150300	2	#10-16 x 1/2" Hex Washer TEK Screw
5	150100	2	#8-32 x 1/2" Phillips Round Head Machine Screw
6	132070	1	24 VAC Transformer – 50/60 Hz (for gas models and steam models)
7	151001	2	#8-23 Pal Nut
8	150002	2	#6-32 x 1" Phillips Round Head Machine Screw
9	120715	1	30-Position Terminal Block
10	151000	2	#6-32 Pal Nut
11	150102	*	#8 x 3/8" Phillips Round Head TEK Screw
12	136057	2	1/2-amp (Slo-Blo) Fuse
	182453	1	6-amp (fast acting) Fuse (for electric models)
13	136008	*	Fuse Block / Strip
14	150413	2	#10-16 x 1/2" TORX® Crimptite Screw
15	131932	1	24 VAC Relay (for electric models)
16	150413	1	#10-16 x 1/2" TORX® Crimptite Screw
17	121010	1	L-70 Ground Lug
18	122631	1	6-Pin Connector
19	122705	*	Socket Terminal
20	122704	*	Pin Terminal
21	122630	1	6-Pin Connector
	137025	1	6/15-Position Strain Relief ... Not Illustrated
22	122625	1	15-Pin Connector
23	122704	12	Pin Terminal
24	122705	12	Socket Terminal
25	122626	1	15-Pin Socket Connector
—	122801	1	Pin / Socket Extraction Tool

\* As required (either 2 or 3).

# Lint Drawer / Lint Drawer Switch Box Assemblies

For Models Mfd. as of April 12, 2003

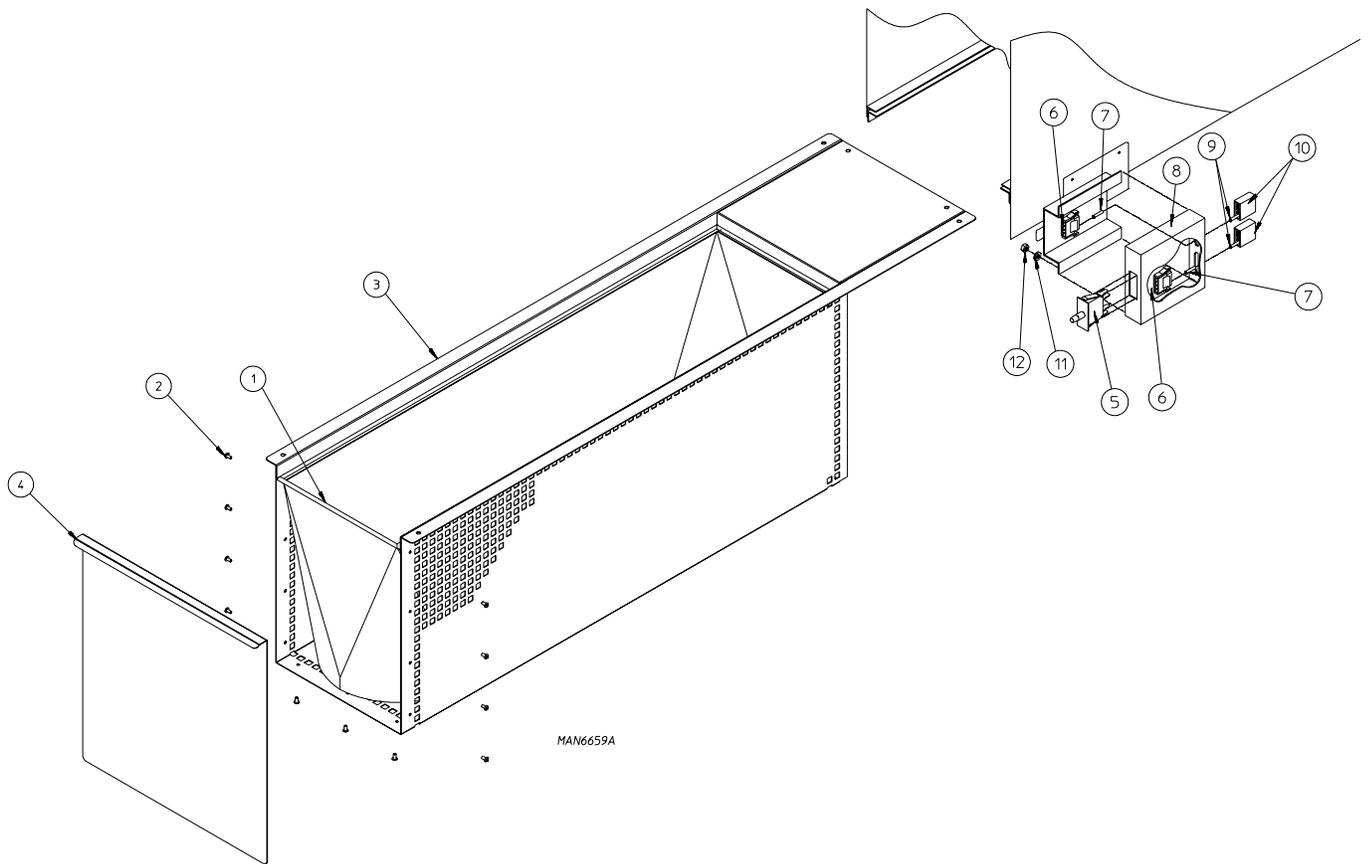

<u>Illus. No.</u>	<u>Part No.</u>	<u>Qty.</u>	<u>Description</u>
1	108209	1	Lint Bag
2	154211	11	Button Head Rivet
3	850948	1	Lint Basket Assembly (includes illus. nos. 1 through 4)
	851099	1	Stainless Steel Lint Basket Assembly (includes illus. nos. 1 through 4)
4	801137	1	Lint Drawer Handle
	801138	1	Stainless Steel Lint Drawer Handle
5	122116	1	Lint Drawer Switch
6	122605	2	4-Pin Connector (female)
7	122701	4	Socket Terminal
	122801	1	Pin / Socket Extraction Tool ... Not Illustrated
8	820138	1	Guarded Lint Drawer Switch Assembly (includes illus. nos. 4 through 7)
8	150301	2	#8-18 x 7/16" Phillips Pan Head TEK Screw
9	122700	4	Pin Terminal
10	122604	2	4-Pin Connector (male)
11	153012	2	#8 Star Washer
12	152001	2	#8-32 x 3/8" Hex Nut

# Lint Drawer / Lint Drawer Switch Box Assemblies

For Models Mfd. prior to April 12, 2003

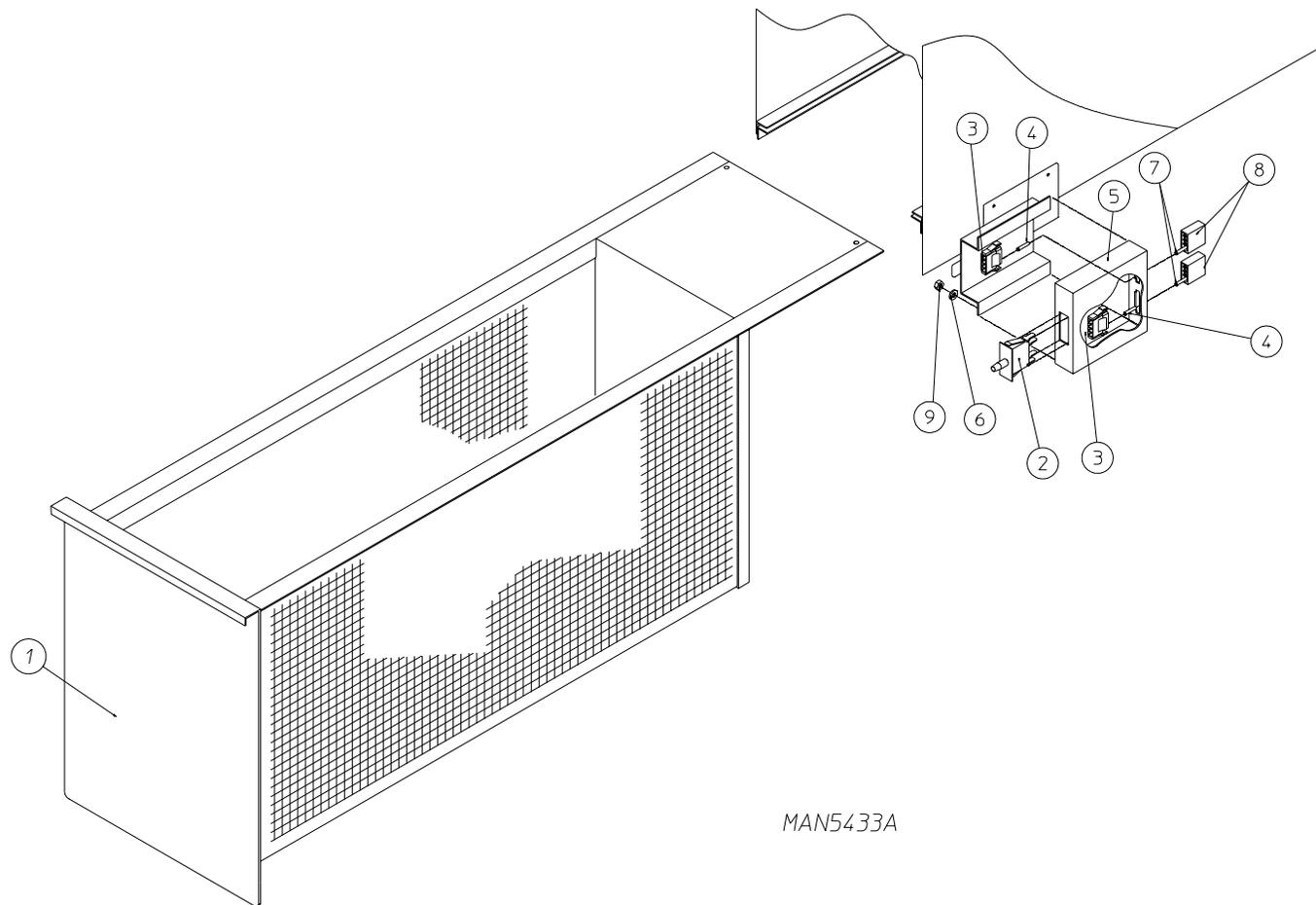

MAN5433A

Illus. No.	Part No.	Qty.	Description
1*	803023	1	Lint Basket Assembly
2	122116	1	Lint Drawer Switch ONLY
3	122605	2	4-Pin Connector (female)
4	122701	4	Socket Terminal ONLY
	122801	1	Pin / Socket Extraction Tool ... Not Illustrated
5	800478	1	Guarded Lint Drawer Switch Assembly (includes illus. nos. 3 through 6)
6	153012	2	#8 Star Washer
7	122700	4	Pin Terminal ONLY
8	122604	2	4-Pin Connector (male)
9	152001	2	#8-32 x 3/8" Hex Nut

\* Specify color when ordering.

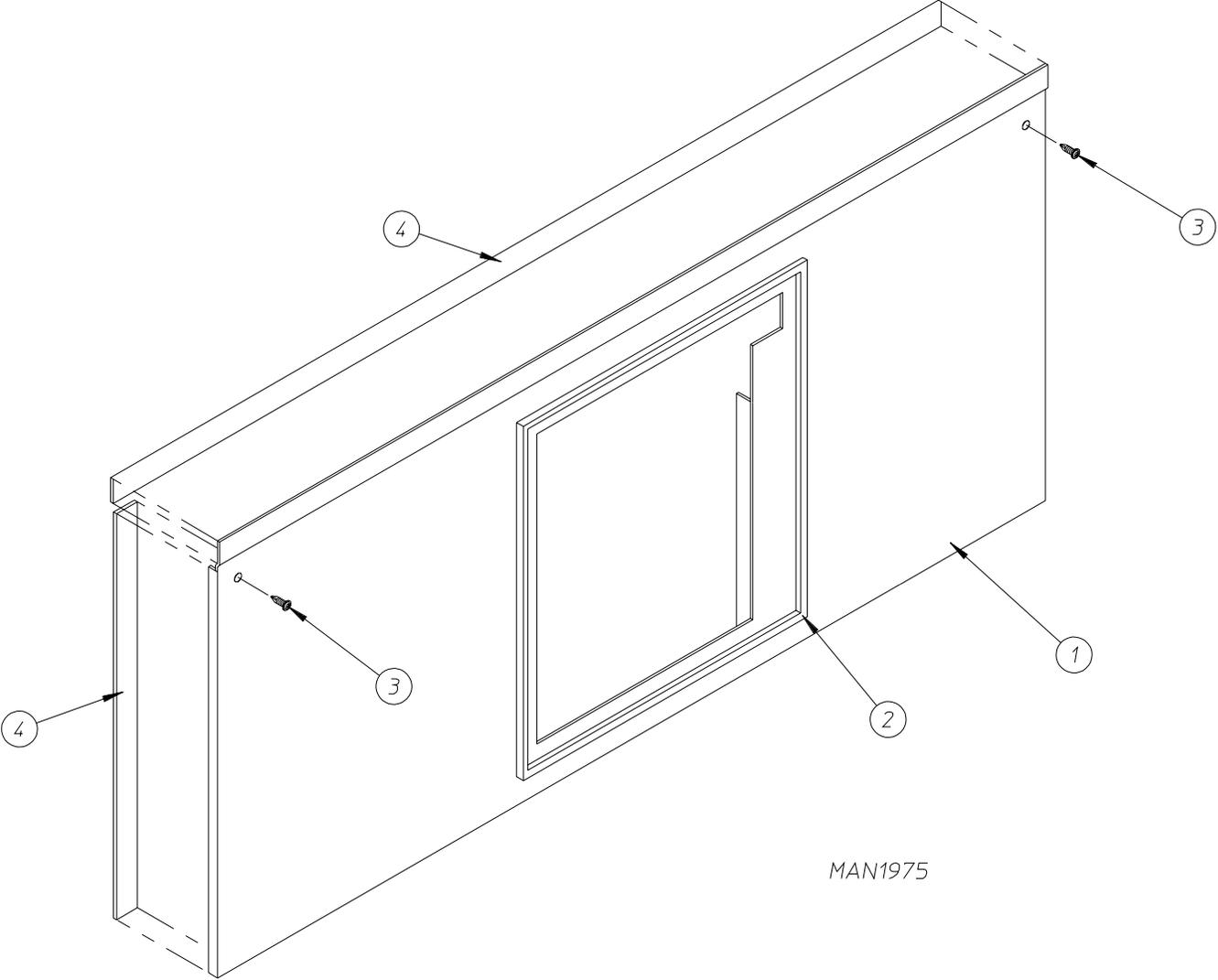

Illus. No.	Part No.	Qty.	Description
1	824258*	1	Drop Lint Door Assembly (includes illus. nos. 1, 2, and 4)
	850485	1	Stainless Steel Drop Lint Door Assembly (includes illus. nos. 1, 2, and 4)
2	117607	6	Gasket (sold by the foot)
3	150309	3	#10-16 x 1/2" Hex Head TEK Crimptite Screw
4	117604	9	Noise Suppression Tape (sold by the foot)

\* Specify color when ordering.

# Front Panel Main Door Assembly

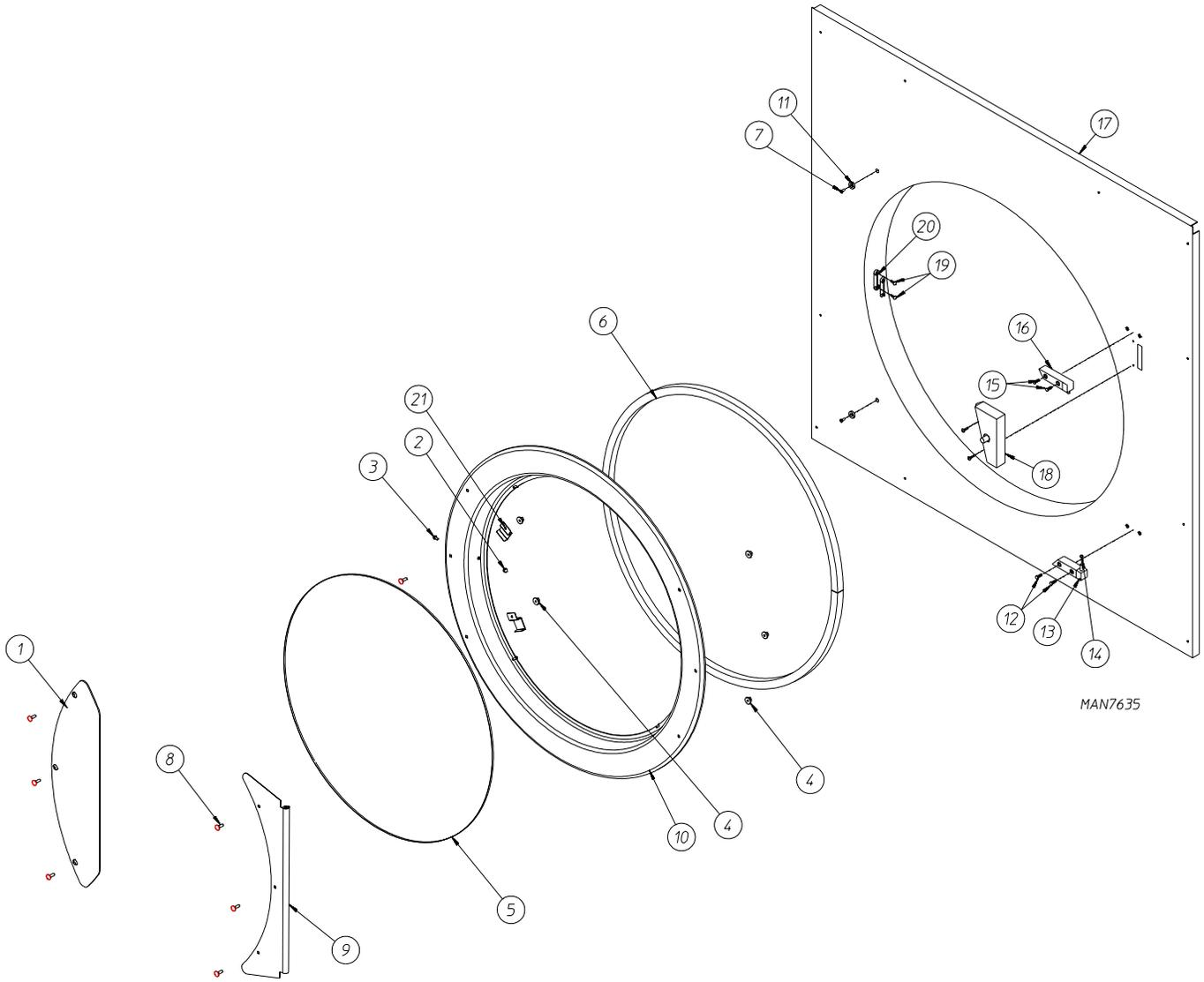

## Front Panel Main Door Assembly

---

<u>Illus. No.</u>	<u>Part No.</u>	<u>Qty.</u>	<u>Description</u>
1*	378096	1	Cold Rolled Steel Main Door Handle
2	151010	1	#10-32 Hex Acorn Lock Nut (black)
3	150120	1	#10-32 x 7/16" Door Latch Screw
4	152014	6	1/4-20 Free Spin Washer
5	102221	1	30" Door Glass
6	102357	1	Large Steel Door Gasket
7	152223	2	T-20 TORX® Screw
8	150683	6	1/4-20 x 5/8" Carriage Bolt
9	835056	1	Door Hinge
10*	801600	1	Cold Rolled Steel Main Door Assembly (for models mfd. as of September 10, 2005)
	835003	1	Cold Rolled Steel Main Door Assembly (for models mfd. prior to September 10, 2005)
11	102004	2	Magnet (for models mfd. as of September 10, 2005)
12	150445	2	Black Socket Cap Screw
13	170331	1	Bottom Hinge Block
14	153031	1	Nylon Washer
15	150445	2	Black Socket Cap Screw
16	170329	1	Top Hinge Block
17	801619	1	Front Panel Assembly (for models mfd. as of September 10, 2005) (includes illus. nos. 7, 11, and 17)
	883806	1	Front Panel Assembly (for models mfd. prior to September 10, 2005) (includes illus. nos. 17, 19, and 20)
18	801786	1	Main Door Switch Housing Assembly
19	154215	2	5/32" x 1/4" Aluminum Rivet (for models mfd. prior to September 10, 2005)
20	170330	1	Friction Door Latch (for models mfd. prior to September 10, 2005)
21	185522	2	Main Door Magnet Bracket (for models mfd. as of September 10, 2005)

\* Specify color when ordering.

# Microprocessor Temperature Sensor Bracket Assembly

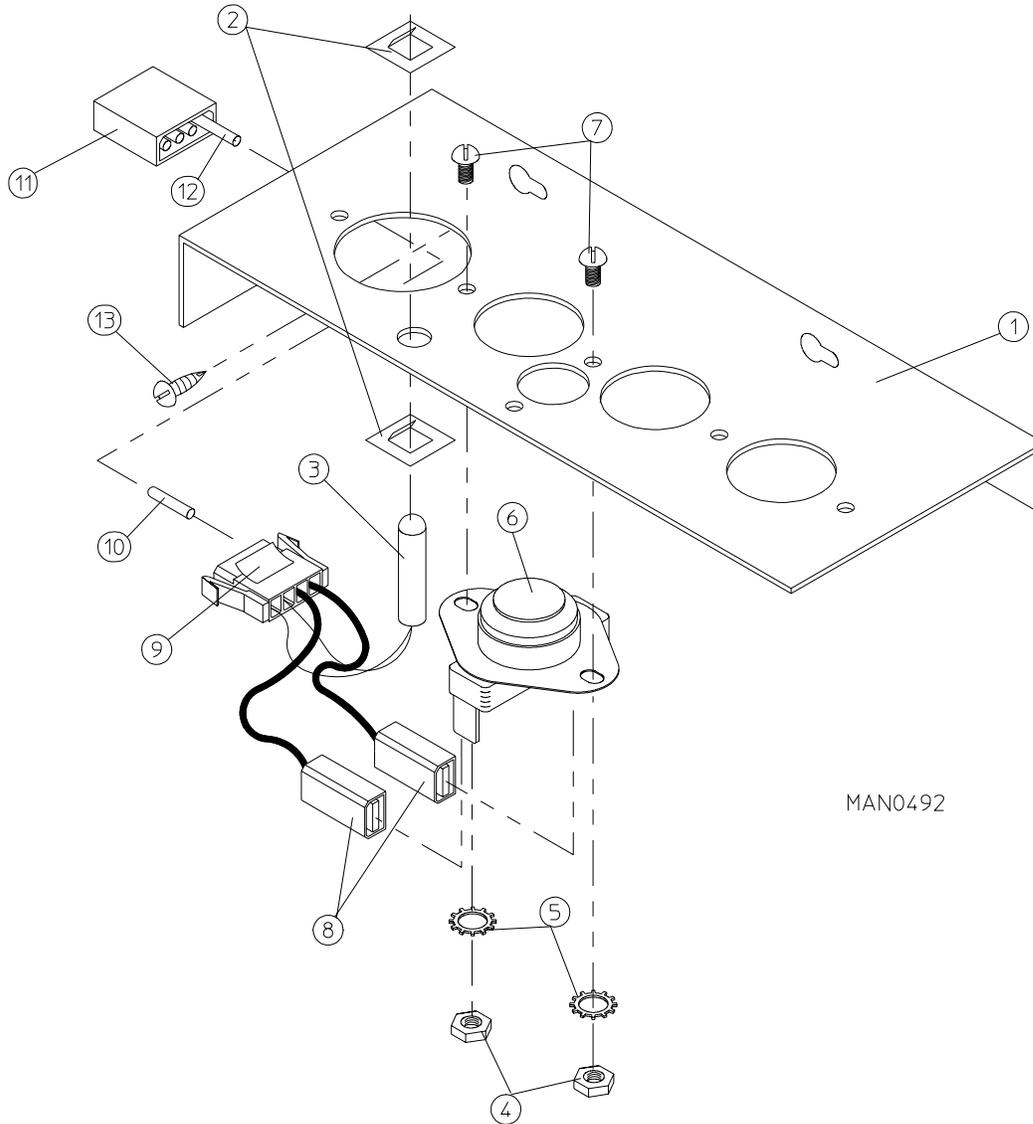

MAN0492

Illus. No.	Part No.	Qty.	Description
1	820022	1	Temperature Sensor Bracket Assembly Complete (includes illus. nos. 1 through 10)
	331295	1	Temperature Sensor Bracket ONLY
2	154007	2	1/4" Tinnerman Push-On Fastener
3	880251	1	1/4" Temperature Sensor Probe Assembly (includes illus. nos. 2, 3, and 8 through 10)
4	152000	2	#6-32 Hex Nut
5	153010	2	#6 Star Washer
6	130112	1	225° Large Automatic Reset Thermostat
7	150005	2	#6-32 x 1/4" Phillips Round Head Machine Screw
8	121028	2	1/4" x 0.032 Insulated Terminal
9	122605	1	4-Pin Connector (female)
10	122701	4	Socket Terminal
11	122604	1	4-Pin Connector (male)
12	122700	4	Pin Terminal
	122801	1	Pin / Socket Extraction Tool ... Not Illustrated
13	150301	2	#8-18 x 7/16" Phillips Pan Head TEK Screw

# Non-Microprocessor Temperature Sensor Bracket Assembly

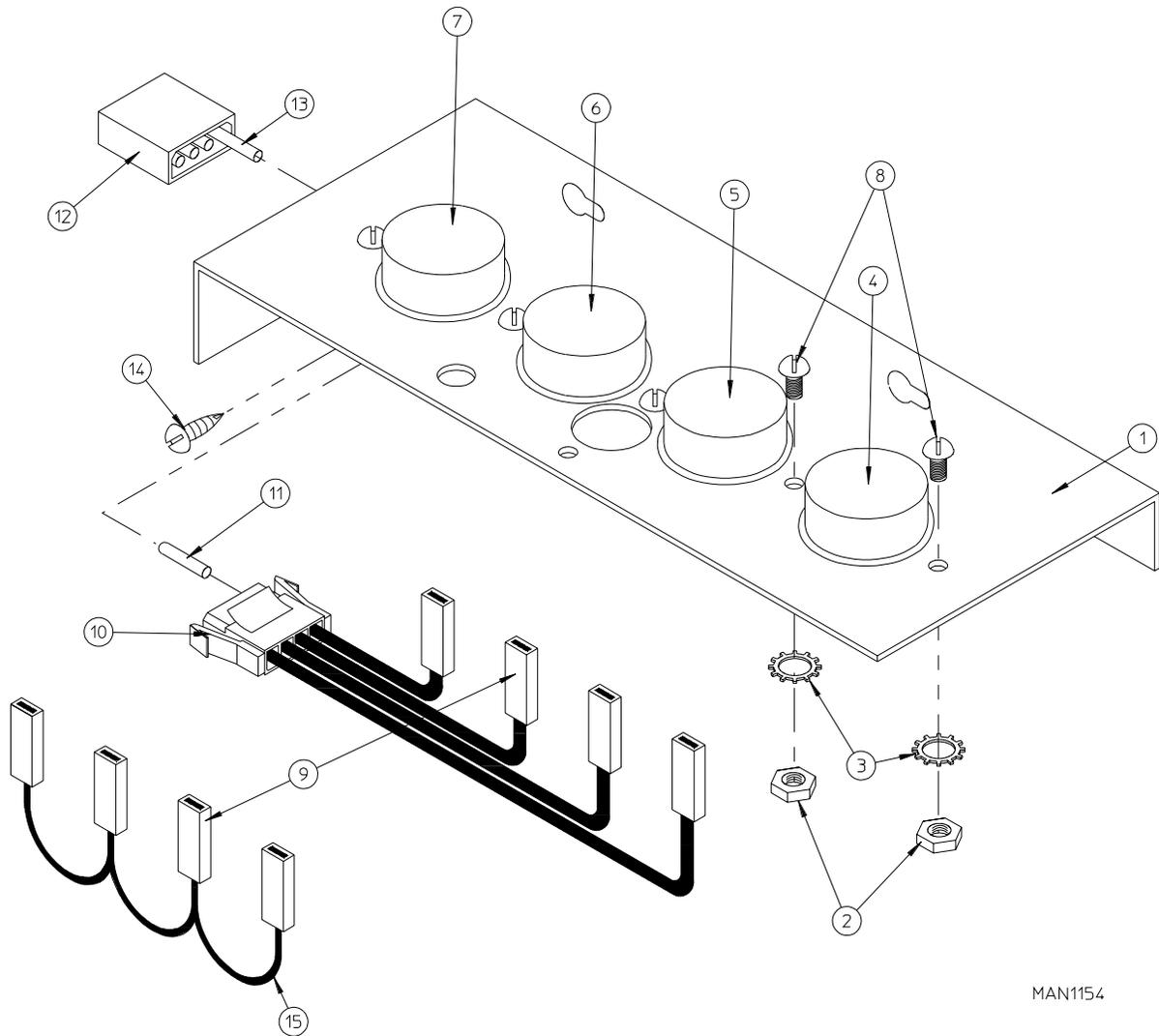

MAN1154

<u>Illus. No.</u>	<u>Part No.</u>	<u>Qty.</u>	<u>Description</u>
1	801404	1	Non-Microprocessor Sensor Bracket Assembly Complete (includes illus. nos. 1 through 11 and 15)
	331295	1	Temperature Sensor Bracket ONLY
2	152000	5	#6-32 Hex Nut
3	153010	5	#6 Star Washer
4	130101	1	180° Large Thermostat
5	130109	1	140° Large Thermostat
6	130107	1	160° Large Thermostat
7	130112	1	225° Large Automatic Reset Thermostat
8	150005	5	#6-32 x 1/4" Phillips Round Head Machine Screw
9	121028	8	1/4" x 0.032 Insulated Terminal
10	122605	1	4-Pin Connector (female)
11	122701	4	Socket Terminal
12	122604	1	4-Pin Connector (male)
13	122700	4	Pin Terminal
	122801	1	Pin / Socket Extraction Tool ... Not Illustrated
14	150301	2	#8-18 x 7/16" Phillips Pan Head TEK Screw
15	824724	1	Sensor Jumper Harness

# Tumbler / Support Assemblies

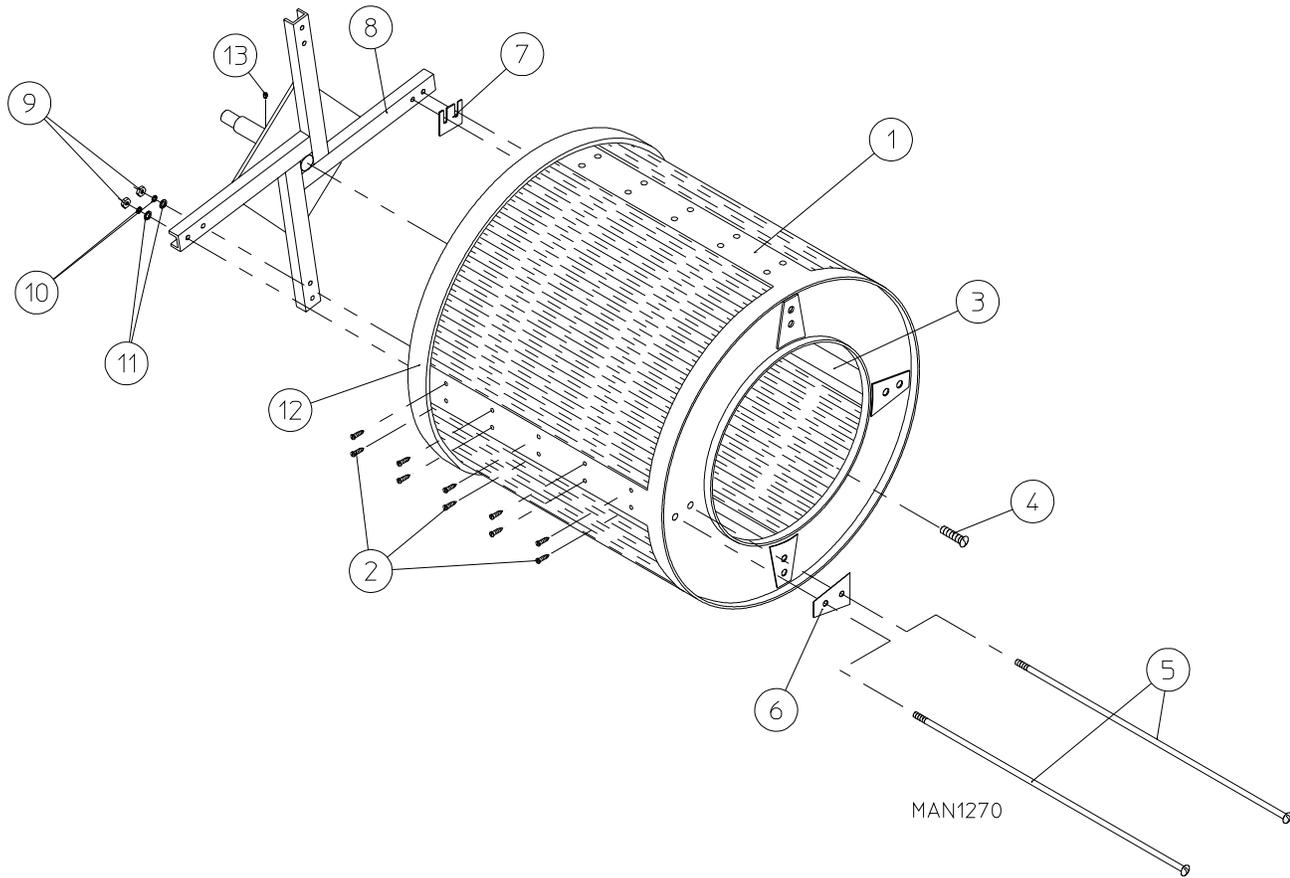

Illus. No.	Part No.	Qty.	Description
1	800707*	1	Tumbler ONLY
	820054	1	Tumbler and Support Assembly Complete (includes illus. nos. 1 through 12)
2	150309	40	#10-16 x 1/2" Hex Head TEK Crimptite Screw
3	301300	4	Tumbler Rib
4	150500	1	5/16-18 x 3/4" Socket Button Head Screw
5	100909	8	1/2-13 x 43" Tie Rod
6	301700	4	Tumbler Reinforcing Plate
7	301701	**	Tumbler Shim
8	850062	1	Tumbler Support
9	152011	8	1/2-13 Hex Nut
10	153026	16	1/2" Lock Washer
11	153014	8	7/16" Flat Washer
12	116004	1	Felt Collar
	401010	1	#847 Adhesive for Felt Collar ... Not Illustrated
13	821002	1	Rotation Magnet Holder Assembly

\* Felt collar is not included and must be ordered separately.

\*\* As required.

# Tumbler Bearing Mount Assembly

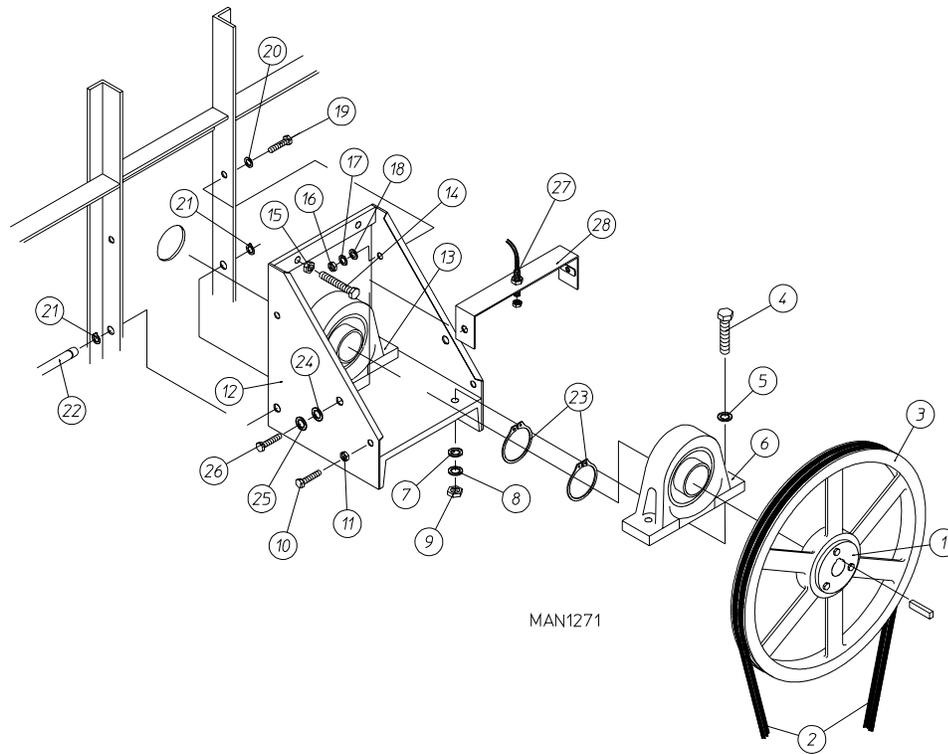

<u>Illus. No.</u>	<u>Part No.</u>	<u>Qty.</u>	<u>Description</u>
1	101108	1	2-1/4" SK Bushing
2*	100104	2	A68 V-Belt
3	101111	1	18" Tumbler Pulley
4	150602	4	5/8-11 x 3" Hex Head Machine Bolt
5	153016	4	5/8" Flat Washer
6	880204	1	2-1/4" Pillow Bearing
7	153016	4	5/8" Flat Washer
8	153015	4	5/8" Lock Washer
9	152010	4	5/8-11 Hex Nut
10	150600	2	3/8-16 x 1-1/2" Hex Head Machine Bolt
11	152005	2	3/8-16 Hex Nut
12	801102	1	Tumbler Bearing Mount Assembly (includes illus. nos. 4 through 13)
13	880204	1	2-1/4" Pillow Bearing
14	150603	2	1/2-13 x 3" Square Head Machine Bolt
15	152011	2	1/2-13 Hex Nut
16	152005	2	3/8-16 Hex Nut
17	153005	2	3/8" Lock Washer
18	153004	4	3/8" Flat Washer
19	150600	2	3/8-16 x 1-1/2" Hex Head Machine Bolt
20	153004	2	3/8" Flat Washer
21	100801	2	5/8" Retaining Ring
22	301810	1	5/8" Hinge Pin
23	100811	2	2-1/4" Retaining Ring
24	153018	2	1/4" Flat Washer
25	153007	2	1/4" Split Lock Washer
26	150512	2	1/4-20 x 1/2" Hex Head Machine Bolt
27	822735	1	Rotational Sensor Assembly
28	880841	1	Rotational Sensor Mounting Bracket

\* Replace in matched sets (both belts).

# Idler Bearing Mount Assembly

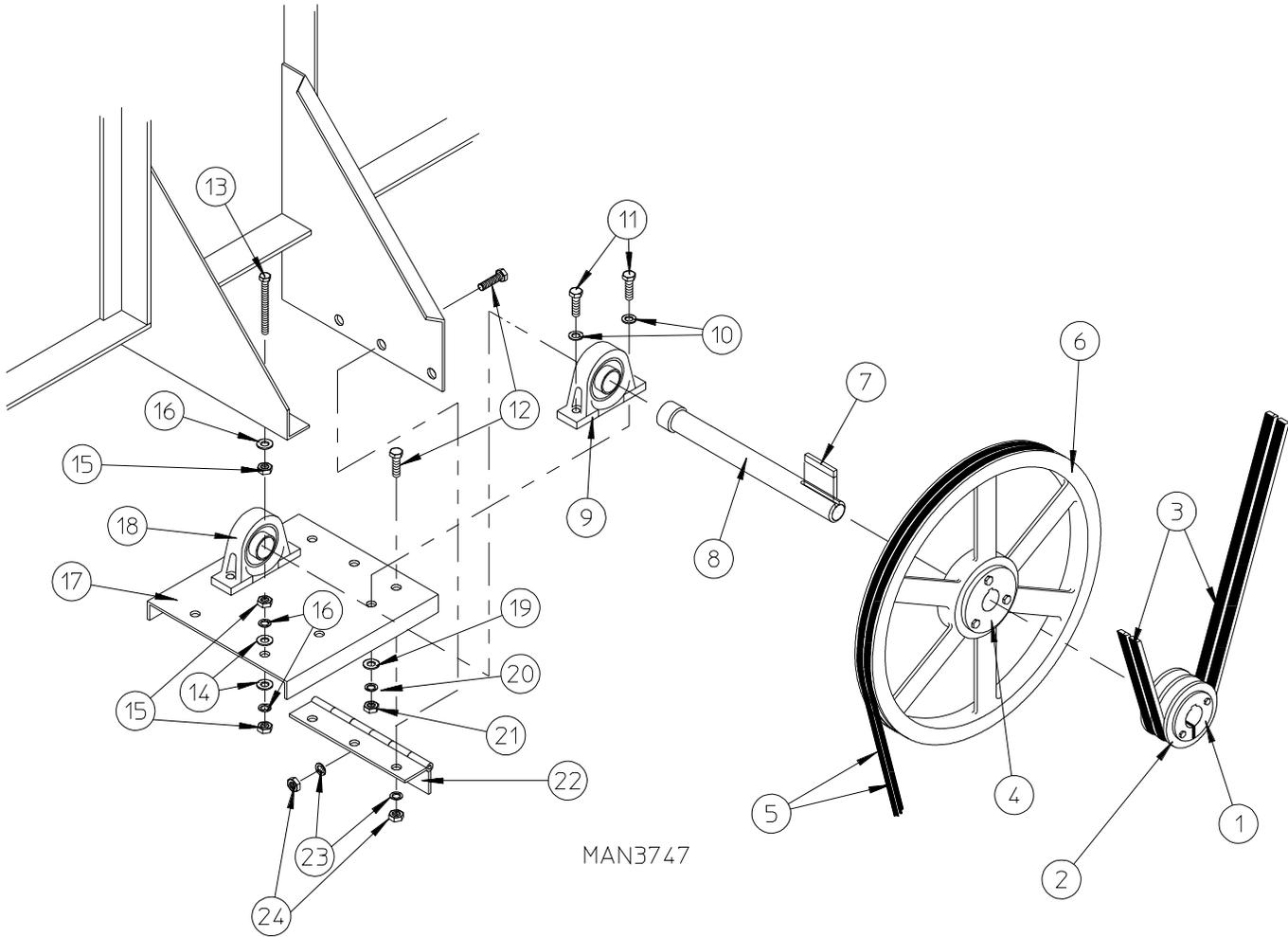

<u>Illus. No.</u>	<u>Part No.</u>	<u>Qty.</u>	<u>Description</u>
1	101110	1	1" Bushing
2	101113	1	2A3.0 Pulley
3*	100104	2	A68 V-Belt
4	101107	1	1" SK Bushing
5*	100102	2	3V 740 V-Belt
6	101112	1	19" Idler Pulley
7	100715	1	1/4" x 1/4" x 4-5/8" Key
8	301852	1	1" Idler Shaft
9	880205	1	1" Pillow Block Bearing with Setscrews
10	153004	4	3/8" Flat Washer
11	150600	4	3/8-16 x 1-1/2" Hex Head Machine Bolt
12	150510	6	1/4-20 x 1/2" Hex Head Machine Bolt
13	150509	2	5/16-18 x 3" Hex Head Machine Bolt
14	153001	6	5/16" Flat Washer
15	152004	6	5/16-18 Hex Nut
16	153002	4	5/16" Lock Washer
17	801001	1	Idler Bearing Mount Assembly Complete (includes illus. nos. 8 through 11 and 17 through 24)
	311401	1	Idler Bearing Mount ONLY
18	880205	1	1" Pillow Block Bearing with Setscrews
19	153004	4	3/8" Flat Washer
20	153005	4	3/8" Lock Washer
21	152005	4	3/8-16 Hex Nut
22	103005	1	Idler Adjustment Hinge
23	153007	6	1/4" Lock Washer
24	152002	6	1/4-20 Hex Nut

\* Replace in matched sets (both belts).

# T.E.F.C. Tumbler Motor Mount Assembly

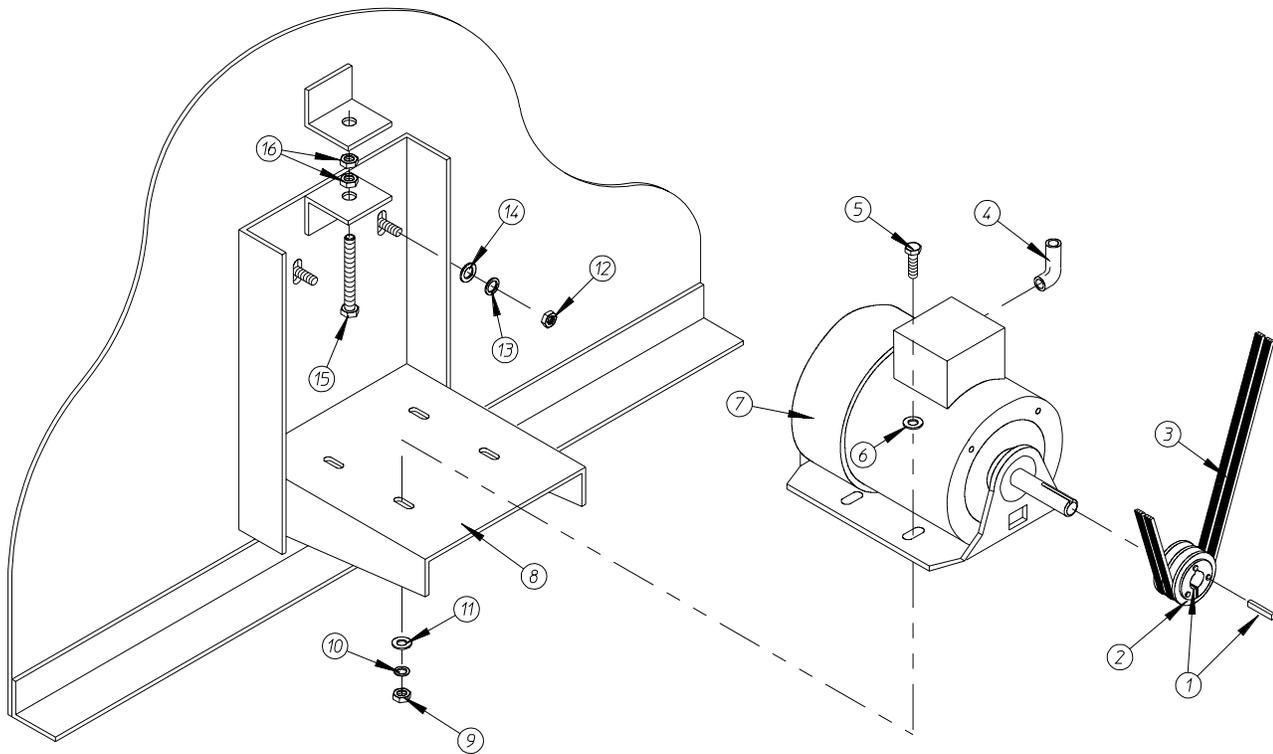

MAN0329

Illus. No.	Part No.	Qty.	Description
1	101121	1	5/8" SK Bushing
2	101114	1	2.65" Pulley (for 60 Hz models Only)
	101120	1	3.15" Pulley (for 50 Hz models Only)
3*	100102	2	3V 740 V-Belt
4	120201	1	1/2" x 90° Connector
5	150501	4	5/16-18 x 3/4" Hex Head Machine Bolt
6	153001	4	5/16" Flat Washer
7	100029	1	3/4 hp 208 / 230 / 280 / 460V 3ø 50 / 60 Hz Totally Enclosed, Fan-Cooled Motor (56Z frame)
8	800952	1	Tumbler Motor Mount ONLY (56Z frame)
	800953**	1	Totally Enclosed, Fan-Cooled Tumbler Motor Mount Assembly Complete for 60 Hz Models ONLY (includes illus. nos. 1, 2, 5 through 11, 15, and 16)
	800955**	1	Totally Enclosed, Fan-Cooled Tumbler Motor Mount Assembly Complete for 50 Hz Models ONLY (includes illus. nos. 1, 2, 5 through 11, 15, and 16)
9	152004	4	5/16-18 Hex Nut
10	153002	4	5/16" Lock Washer
11	153001	4	5/16" Flat Washer
12	152004	4	5/16-18 Hex Nut
13	153002	4	5/16" Lock Washer
14	153001	4	5/16" Flat Washer
15	150619	1	3/18-16 x 3" Hex Head Machine Bolt
16	152005	2	3/8-16 Hex Nut

\* Replace in matched sets (both belts).

\*\* Specify voltage when ordering.

**IMPORTANT:** For voltages higher than 460 VAC – 50 Hz, contact the factory for correct part number of motor or motor mount assembly.

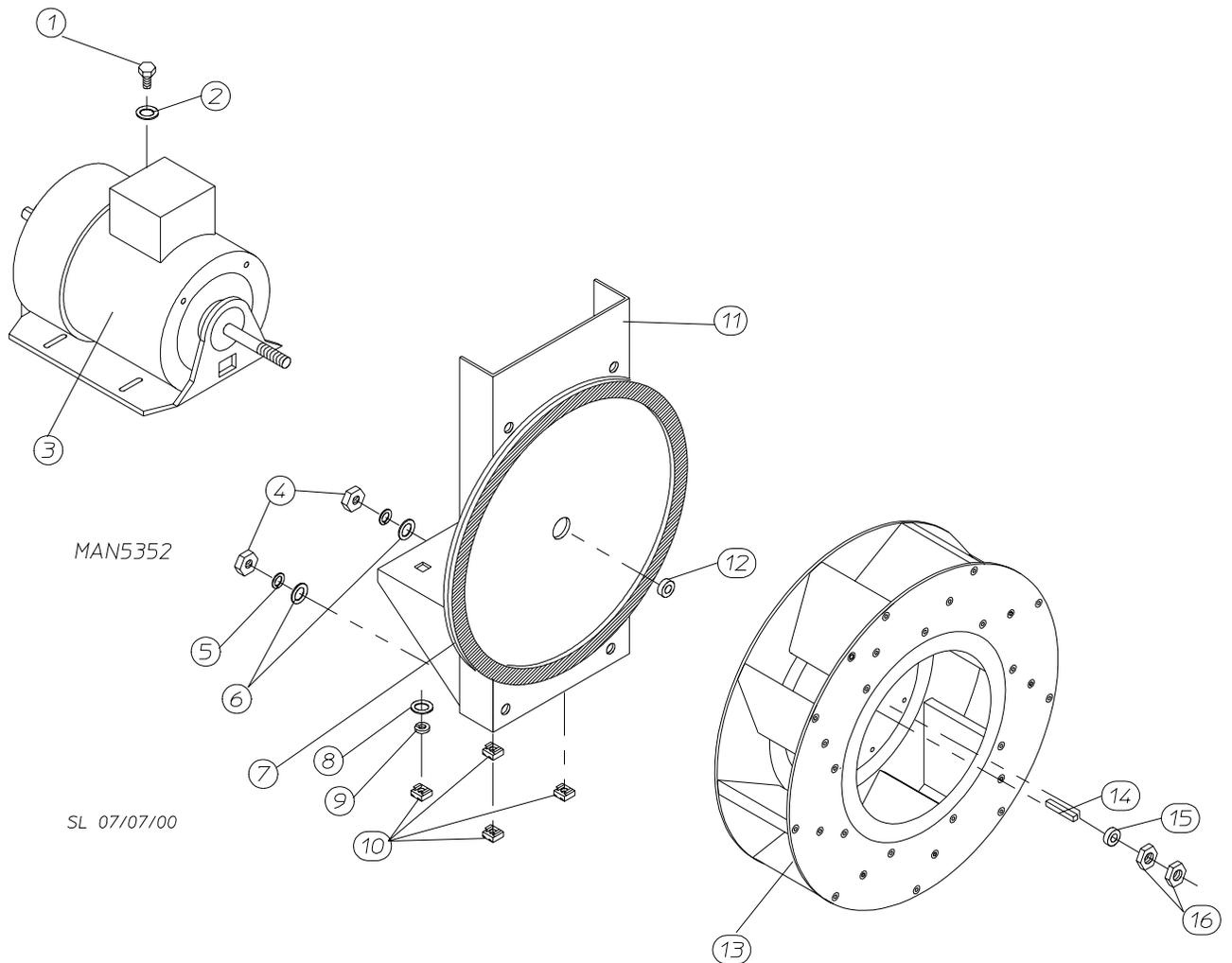

Illus. No.	Part No.	Qty.	Description
1	150504	4	5/16-18 x 1" Hex Head Bolt
2	153001	4	5/16" Flat Washer
3	181043	1	3 hp Motor 208 / 230 / 380 / 460V 60 Hz and 220-416V 50 Hz
4	152004	4	5/16-18 Hex Nut
5	153002	4	5/16" Lock Washer
6	153001	4	5/16" Flat Washer
7	117604	4	Noise Suppression Tape (sold by the foot)
8	153001	4	5/16" Flat Washer
9	153002	4	5/16" Lock Washer
10	152004	4	5/16-18 Hex Nut
11	803561	1	Blower Motor Mount
12	153055	1	5/8" Motor Washer
13	802027	1	16" Riveted High Flow Impellor 7/8" Bore (60 Hz dryers)
	802024	1	16" Riveted Impellor 7/8" Bore (50 Hz dryers)
14	100705	1	3/16" x 3/16" x 1-3/8" Key
15	153055	1	5/8" Motor Washer
16	152006	2	1/2-20 Left Hand Jam Nut



## Direct Spark Ignition Burner Assembly

<u>Illus. No.</u>	<u>Part No.</u>	<u>Qty.</u>	<u>Description</u>
1	820201	1	Burner Box
2	142924	1	1" to 3/4" Reducing Coupling
3	331291	1	Pipe Bracket
4	150309	34	#10-16 x 1/2" Hex Head TEK Crimptite Screw
5	142807	1	3/4" x 40" Nipple
6	142854	1	3/4" Street Elbow
7	142601	1	3/4" Union
8	142710	1	3/4" x 4" Nipple
9	390125	1	Flat Gas Pipe Bracket
10	887159	1	Gas Valve (for natural gas)
	887155	1	Gas Valve (for liquid propane gas)
11	331088	1	Extended Pipe Bracket (bent)
12	120910	2	#10-32 Type F Green Ground Screw
13	883849	1	Direct Spark Ignition Module with High Voltage Wire
14	141219	1	3-Port Manifold
15	140837	3	#8 Burner Orifice (natural gas)
	140818	3	#31 Burner Orifice (liquid propane gas)
	887231	1	Liquid Propane Conversion Kit (for models mfd. as of June 19, 2007)
	880876	1	Liquid Propane Conversion Kit (for models mfd. prior to June 19, 2007)
16	335031	1	Direct Spark Ignition Manifold Rest
17	141136	3	Burner Tube
18	331287	1	Burner Tube Support
19	121007	1	1 Female / 3 Male 1/4" Adaptor
20	331289	1	Burner Box Cover Plate
21	331290	1	Ignitor / Flame-Probe Sight Hole Disc
22	128915	1	Ignitor / Flame-Probe Assembly
23	884278	1	High Voltage Wire (for models with 1/4" spade connection at module)
	880330	1	High Voltage Wire (for models with spike style connection at module)
24	151000	4	#6-32 Pal Nut
25	130201	1	330° Manual Reset Hi-Limit
26	150001	2	#6-32 x 1/2" Machine Screw
27	821457	1	Hi-Limit Bracket
28	————	1	Sail Switch Assembly <b>(refer to Sail Switch Assembly on page 24)</b>
29	822513	1	Fenwal Ground Wire
30	153017	2	#6 Flat Washer
31	150002	2	#6-32 x 1" Phillips Round Head Machine Screw
32	121300	1	Open / Closed Bushing
33	332256	1	Liquid Propane Burner Baffle

# Sail Switch Assembly

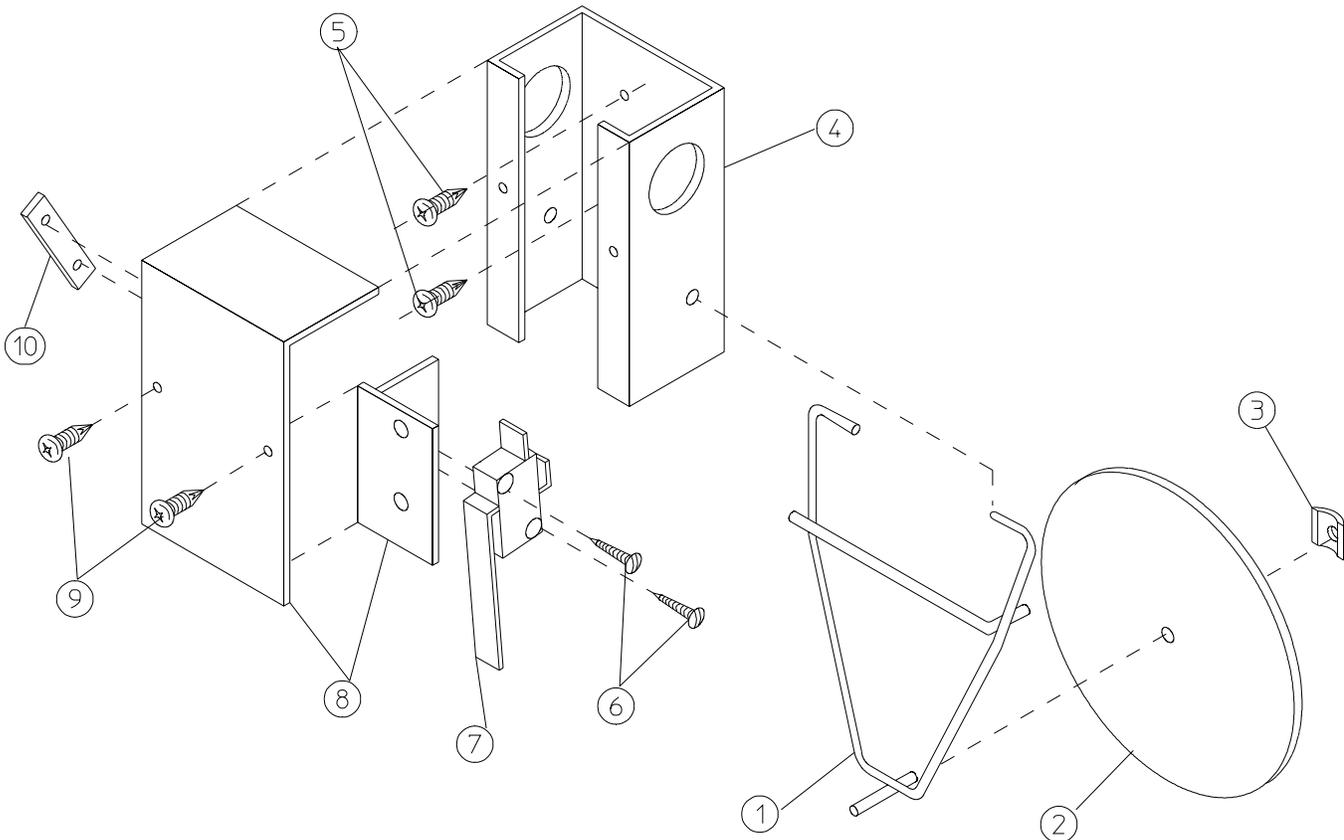

MAN0440

<u>Illus. No.</u>	<u>Part No.</u>	<u>Qty.</u>	<u>Description</u>
1	105500	1	Sail Switch Actuator Rod
2	319202	1	Sail Switch Damper (flat)
3	154002	1	1/8" Push-On Fastener
4	802800	1	Sail Switch Box with Cover and Bracket ONLY
	802801	1	Sail Switch Box Assembly Complete (includes illus. nos. 1 through 4 and 6 through 10)
5	150300	2	#10 x 1/2" Hex Washer TEK Screw
6	150303	2	#4 x 3/4" Pan Head "A" Machine Screw
7	122200	1	Sail Switch ONLY
8	802799	1	Sail Switch Box Cover and Bracket ONLY
9	150309	2	#10-16 x 1/2" Hex Head TEK Crimptite Screw
10	154004	1	Twin Speed Nut

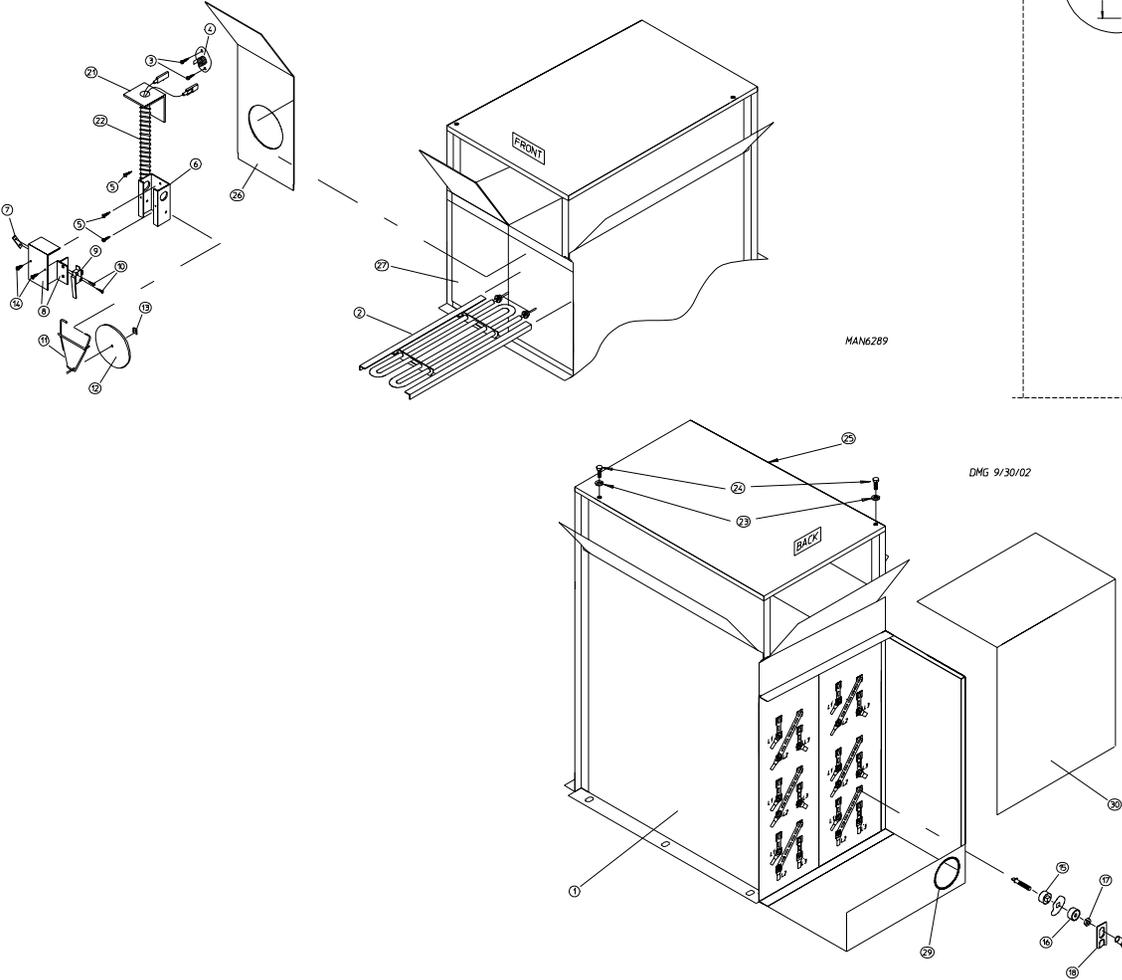
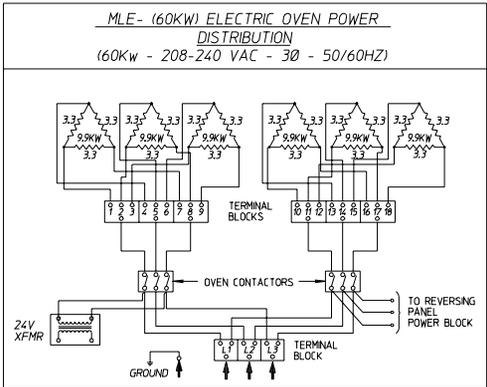
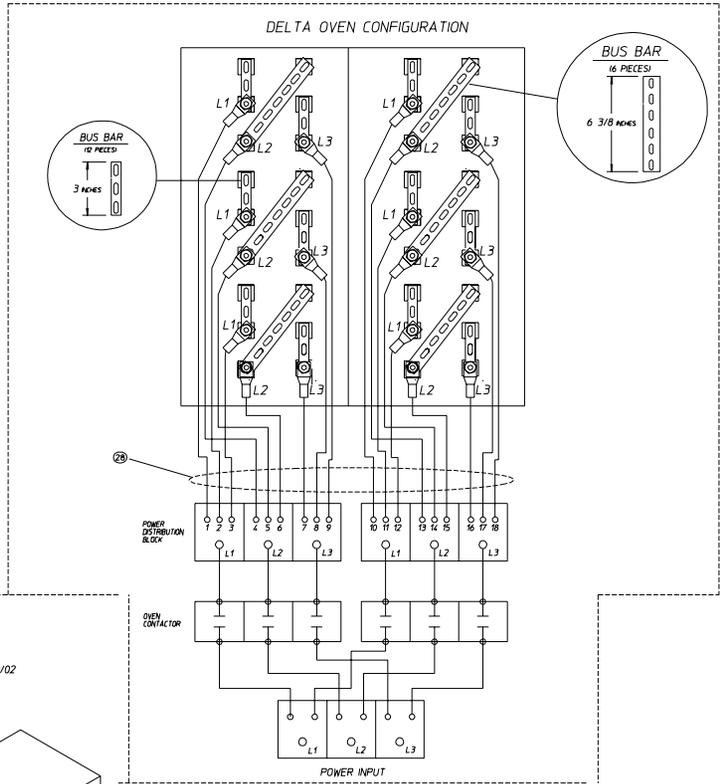

## 60 kW 208-240 Volt Electric Oven Assembly

---

<u>Illus. No.</u>	<u>Part No.</u>	<u>Qty.</u>	<u>Description</u>
1	815998	1	Electric Oven Box ONLY
2	120075	18	208v 3.3 kW Open Coil Element
	120076	18	240v 3.3 kW Open Coil Element
3	150301	2	#8-18 x 7/16" Phillips Pan Head TEK Screw
4	130400	1	290° Hi-Limit Thermostat
5	150309	4	#10-16 x 1/2" Hex Head TEK Crimptite Screw
6	319200	1	Sail Switch Box
7	154004	1	Twin Speed Nut
8	802799	1	Sail Switch Box Cover
9	122200	1	Sail Switch ONLY
10	150303	2	#4 x 3/4" Pan Head "A" Machine Screw
11	105500	1	Sail Switch Actuator Rod
12	319202	1	Sail Switch Damper (flat)
13	154002	1	1/8" Push-On Fastener
14	150309	28	#10-16 x 1/2" Hex Head TEK Crimptite Screw
15	120081	36	Internal Ceramic Insulator
16	120080	36	External Ceramic Insulator
17	152008	72	#10-32 Hex Nut
18	121011	6'	Bus Bar (sold by the foot)
19	153009	36	#10 Star Washer
20	121032	18	#8 Connector
21	353222	1	Pipe Bracket
22	802760	1	Hi-Limit and Sail Switch Harness
23	153007	2	1/4" Lock Washer
24	150512	2	1/4-20 x 1/2" Long Bolt
25	819961	1	Burner Cover Assembly
26	331278	1	Right Front Oven Panel
27	331276	1	Left Front Oven Panel
28	815709	1	#8 Oven Assembly Wiring
29	156001	1	Caterpillar Grommet
30	331279	1	Oven Electrical Cover

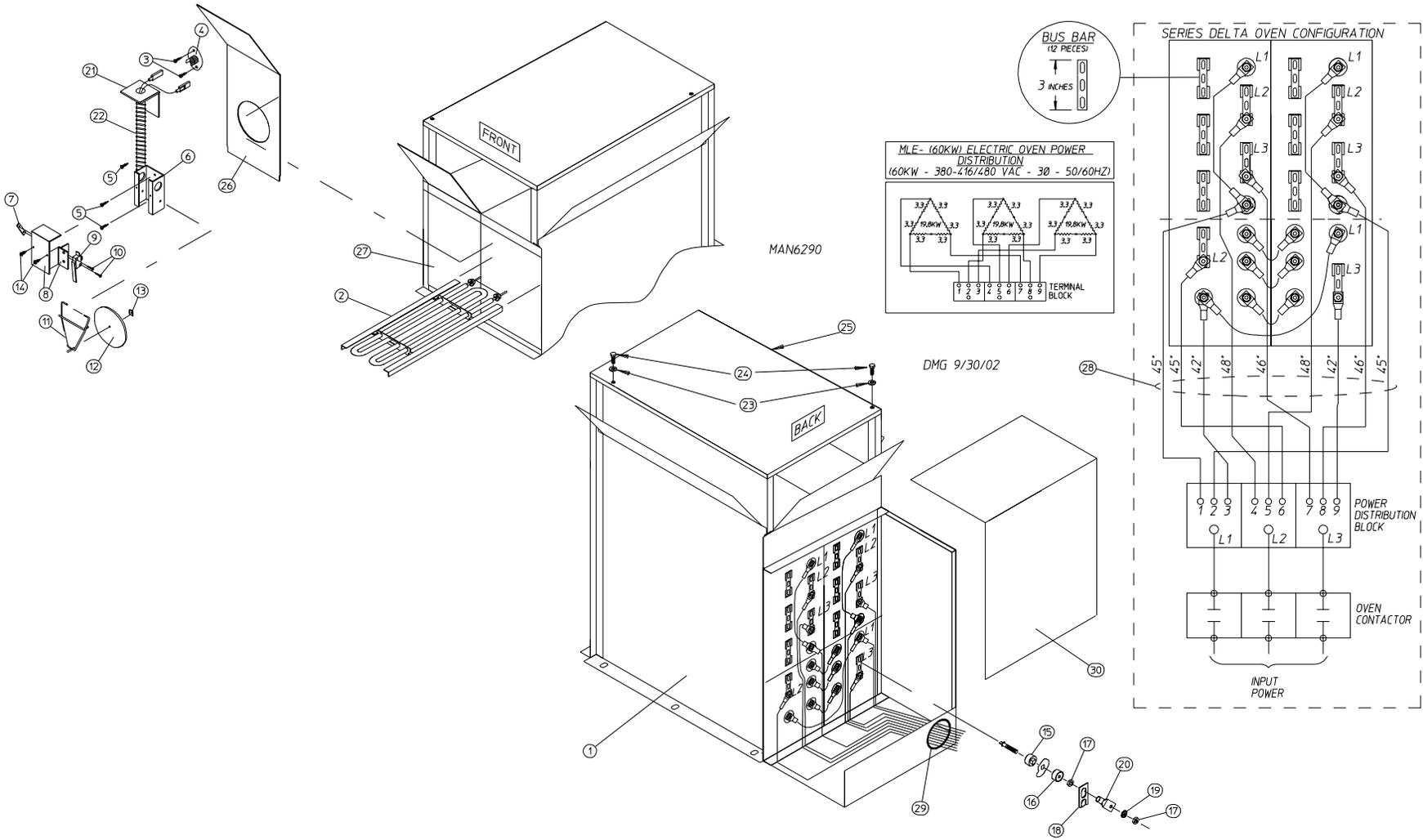

## 60 kW 380-416 / 480 Volt Electric Oven Assembly

---

<u>Illus. No.</u>	<u>Part No.</u>	<u>Qty.</u>	<u>Description</u>
1	815998	1	Electric Oven Box ONLY
2	120074	18	3.3 kW Open Coil Element (for 380v models)
	120075	18	3.3 kW Open Coil Element (for 400-416v models)
	120076	18	3.3 kW Open Coil Element (for 480v models)
3	150301	2	#8-18 x 7/16" Phillips Pan Head TEK Screw
4	130400	1	290° Hi-Limit Thermostat
5	150309	4	#10-16 x 1/2" Hex Head TEK Crimptite Screw
6	319200	1	Sail Switch Box
7	154004	1	Twin Speed Nut
8	802799	1	Sail Switch Box Cover
9	122200	1	Sail Switch
10	150303	2	#4 x 3/4" Pan Head "A" Machine Screw
11	105500	1	Sail Switch Actuator Rod
12	319202	1	Sail Switch Damper (flat)
13	154002	1	1/8" Push-On Fastener
14	150309	28	#10-16 x 1/2" Hex Head TEK Crimptite Screw
15	120081	36	Internal Ceramic Insulator
16	120080	36	External Ceramic Insulator
17	152008	72	#10-32 Hex Nut
18	121011	3'	Bus Bar (sold by the foot)
19	153009	36	#10 Star Washer
20	121032	21	#8 Connector
21	353222	1	Pipe Bracket
22	802760	1	Hi-Limit and Sail Switch Harness
23	153007	2	1/4" Lock Washer
24	150512	2	1/4-20 x 1/2" Long Bolt
25	819961	1	Burner Cover Assembly
26	331278	1	Right Front Oven Panel
27	331276	1	Left Front Oven Panel
28	815710	1	#8 Oven Assembly Wiring
29	156001	1	Caterpillar Grommet
30	331279	1	Oven Electrical Cover

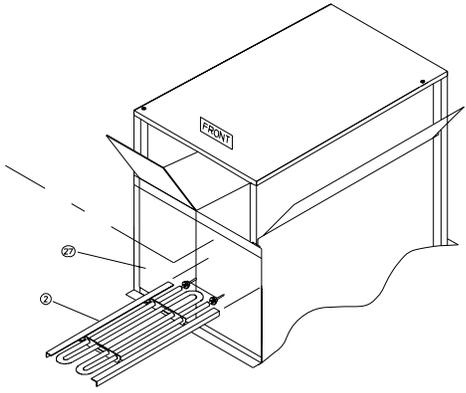
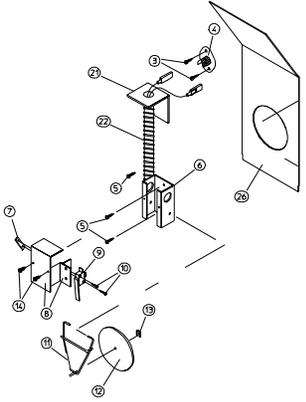

MAN6284

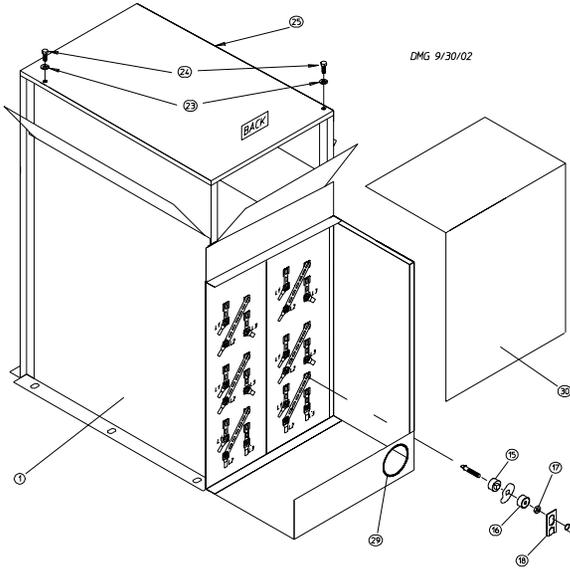

DMG 9/30/02

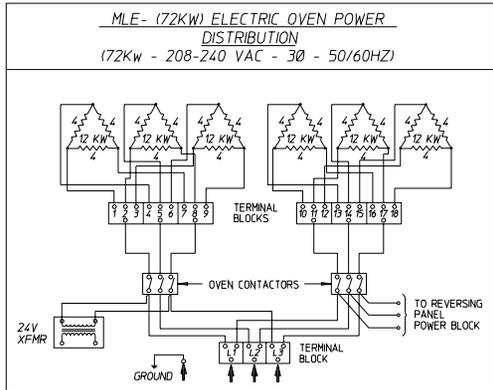
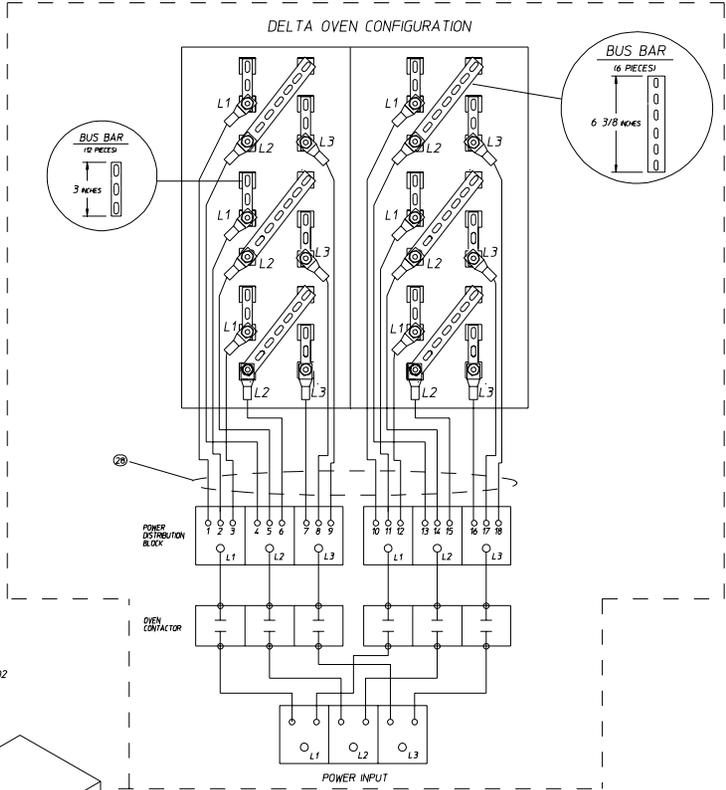

## 72 kW 208-240 Volt Electric Oven Assembly

---

<u>Illus. No.</u>	<u>Part No.</u>	<u>Qty.</u>	<u>Description</u>
1	815998	1	Electric Oven Box ONLY
2	120010	18	208 Volt 4 kW Open Coil Element
	120011	18	240 Volt 4 kW Open Coil Element
3	150301	2	#8-18 x 7/16" Phillips Pan Head TEK Screw
4	130400	1	290° Hi-Limit
5	150309	4	#10-16 x 1/2" Hex Head TEK Crimptite Screw
6	319200	1	Sail Switch Box
7	154004	1	Twin Speed Nut
8	802799	1	Sail Switch Box Cover
9	122200	1	Sail Switch
10	150303	2	#4 x 3/4" Pan Head "A" Machine Screw
11	105500	1	Sail Switch Actuator Rod
12	319202	1	Sail Switch Damper (flat)
13	154002	1	1/8" Push-On Fastener
14	150309	28	#10-16 x 1/2" Hex Head TEK Crimptite Screw
15	120081	36	Internal Ceramic Insulator
16	120080	36	External Ceramic Insulator
17	152008	72	#10-32 Hex Nut
18	121011	6'	Bus Bar (sold by the foot)
19	153009	36	#10 Star Washer
20	121032	36	#8 Connector
21	353222	1	Pipe Bracket
22	802760	1	Hi-Limit and Sail Switch Harness
23	153007	2	1/4" Lock Washer
24	150512	2	1/4-20 x 1/2" Long Bolt
25	819961	1	Burner Cover Assembly
26	331278	1	Right Front Oven Panel
27	331276	1	Left Front Oven Panel
28	815709	1	#8 Oven Assembly Wiring
29	156001	1	Caterpillar Grommet
30	331279	1	Oven Electrical Cover

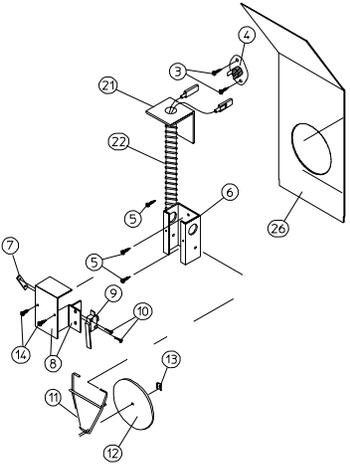
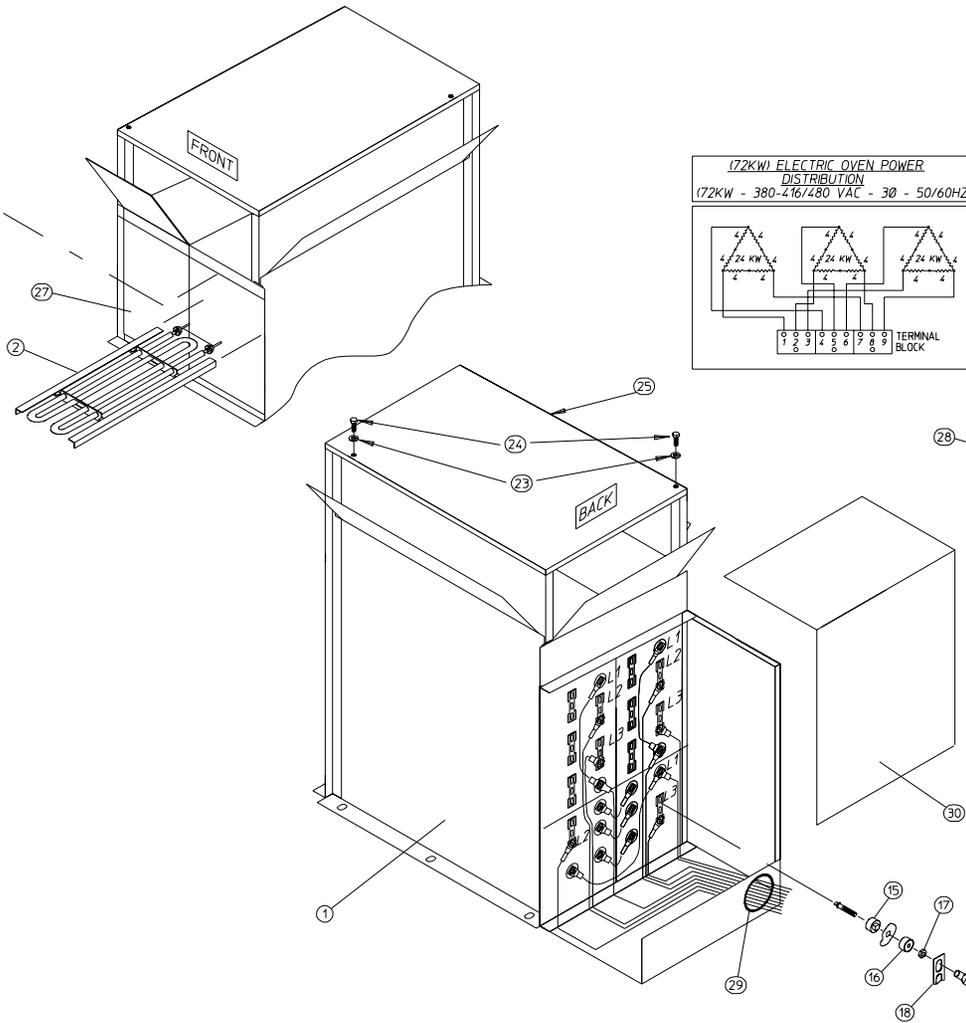
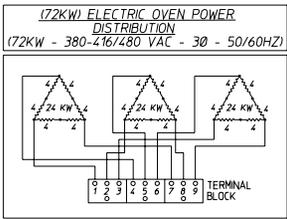
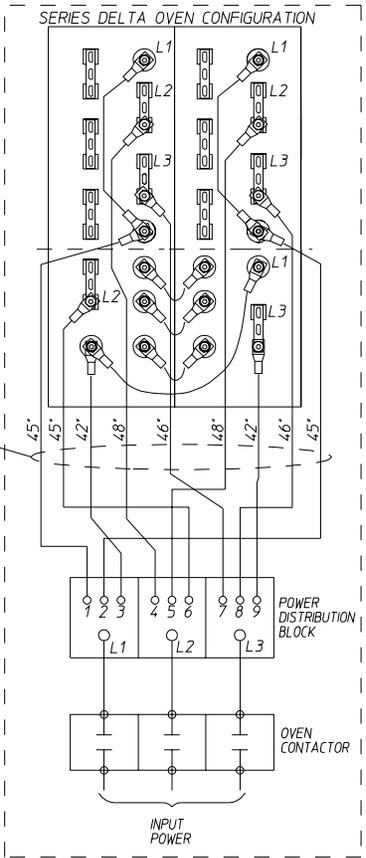

DMG 4/12/02

MAN6134

## 72 kW 380-416 / 480 Volt Electric Oven Assembly

---

<u>Illus. No.</u>	<u>Part No.</u>	<u>Qty.</u>	<u>Description</u>
1	815998	1	Electric Oven Box ONLY
2	120073	18	4 kW Open Coil Element (for 380 volt models)
	120010	18	4 kW Open Coil Element (for 400-416 volt models)
	120011	18	4 kW Open Coil Element (for 480 volt models)
3	150301	2	#8-18 x 7/16" Phillips Pan Head TEK Screw
4	130400	1	290° Hi-Limit
5	150309	4	#10-16 x 1/2" Hex Head TEK Crimptite Screw
6	319200	1	Sail Switch Box
7	154004	1	Twin Speed Nut
8	802799	1	Sail Switch Box Cover
9	122200	1	Sail Switch
10	150303	2	#4 x 3/4" Pan Head "A" Machine Screw
11	105500	1	Sail Switch Actuator Rod
12	319202	1	Sail Switch Damper (flat)
13	154002	1	1/8" Push-On Fastener
14	150309	28	#10-16 x 1/2" Hex Head TEK Crimptite Screw
15	120081	36	Internal Ceramic Insulator
16	120080	36	External Ceramic Insulator
17	152008	72	#10-32 Hex Nut
18	121011	3'	Bus Bar (sold by the foot)
19	153009	36	#10 Star Washer
20	121032	21	#8 Connector
21	353222	1	Pipe Bracket
22	802760	1	Hi-Limit and Sail Switch Harness
23	153007	2	1/4" Lock Washer
24	150512	2	1/4-20 x 1/2" Long Bolt
25	819961	1	Burner Cover Assembly
26	331278	1	Right Front Oven Panel
27	331276	1	Left Front Oven Panel
28	815709	1	#8 Oven Assembly Wiring (for 380-416 volt models)
	815710	1	#8 Oven Assembly Wiring (for 480 volt models)
29	156001	1	Caterpillar Grommet
30	331279	1	Oven Electrical Cover

# 208-240 Volt Oven Relay Box Assembly

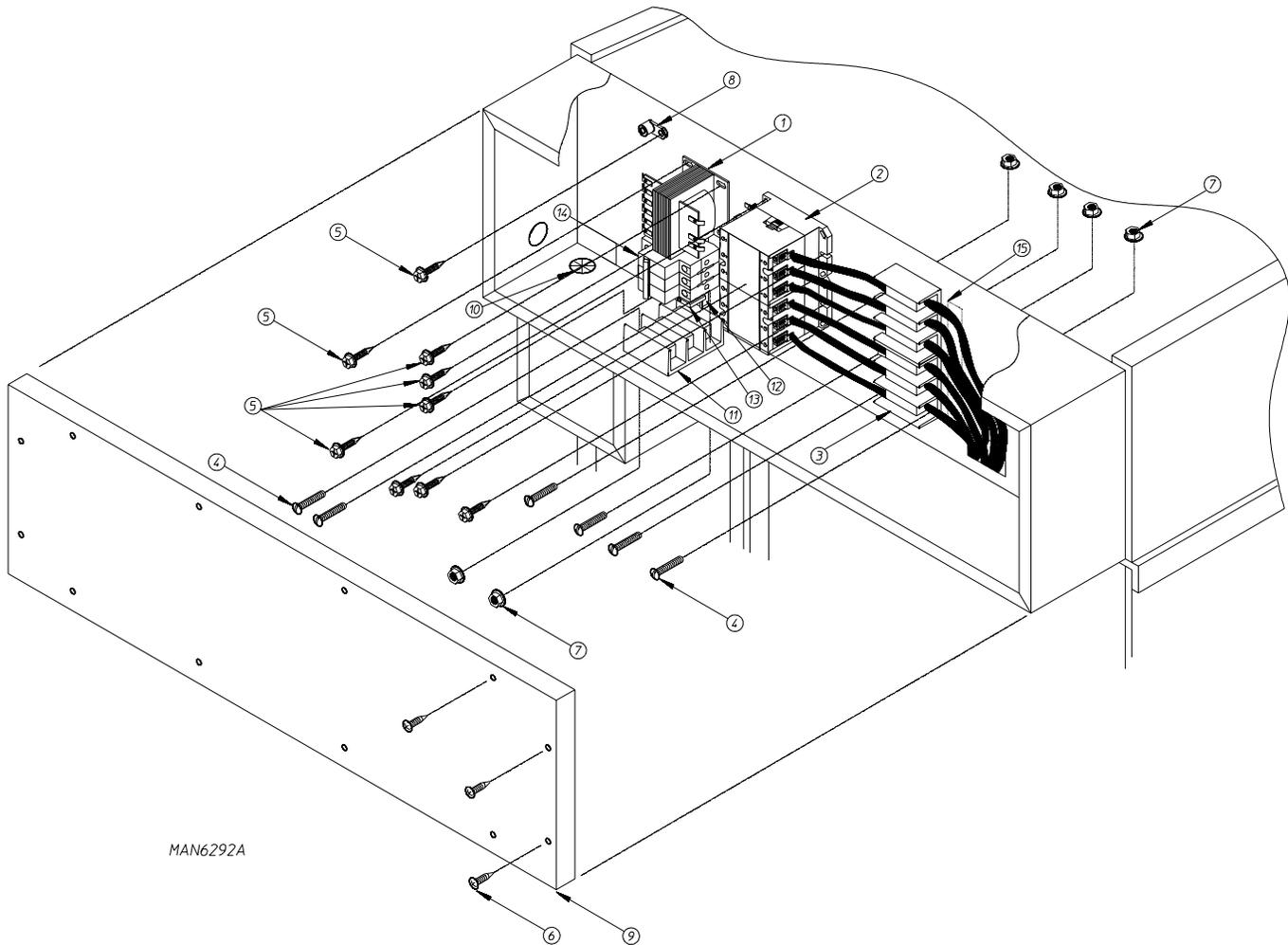

<u>Illus. No.</u>	<u>Part No.</u>	<u>Qty.</u>	<u>Description</u>
1	132087	1	Transformer
2	131362	2	120-amp – 24 VAC Relay
3	120706	2	Power Distribution Block
4	150521	6	1/4-20 x 2" Carriage Bolt
5	150309	9	#10-16 x 1/2" Hex Head TEK Crimptite Screw
6	150301	12	#8-18 x 7/16" Phillips Pan Head TEK Screw
7	152014	6	1/4-20 Free Spin Wash Nut
8	121010	1	L-70 Terminal Lug
9	320909	1	Box Cover
10	121400	1	Universal Bushing
11	120710	1	Power Distribution Block
12	120768	3"	35 x 15mm Din Rail (sold by the inch)
13	120765	2	Din Rail End Stop
14	135499	1	25-amp / 3-Pole Circuit Breaker
15	114518	2	Power Block Label

# 380-480 Volt Oven Relay Box Assembly

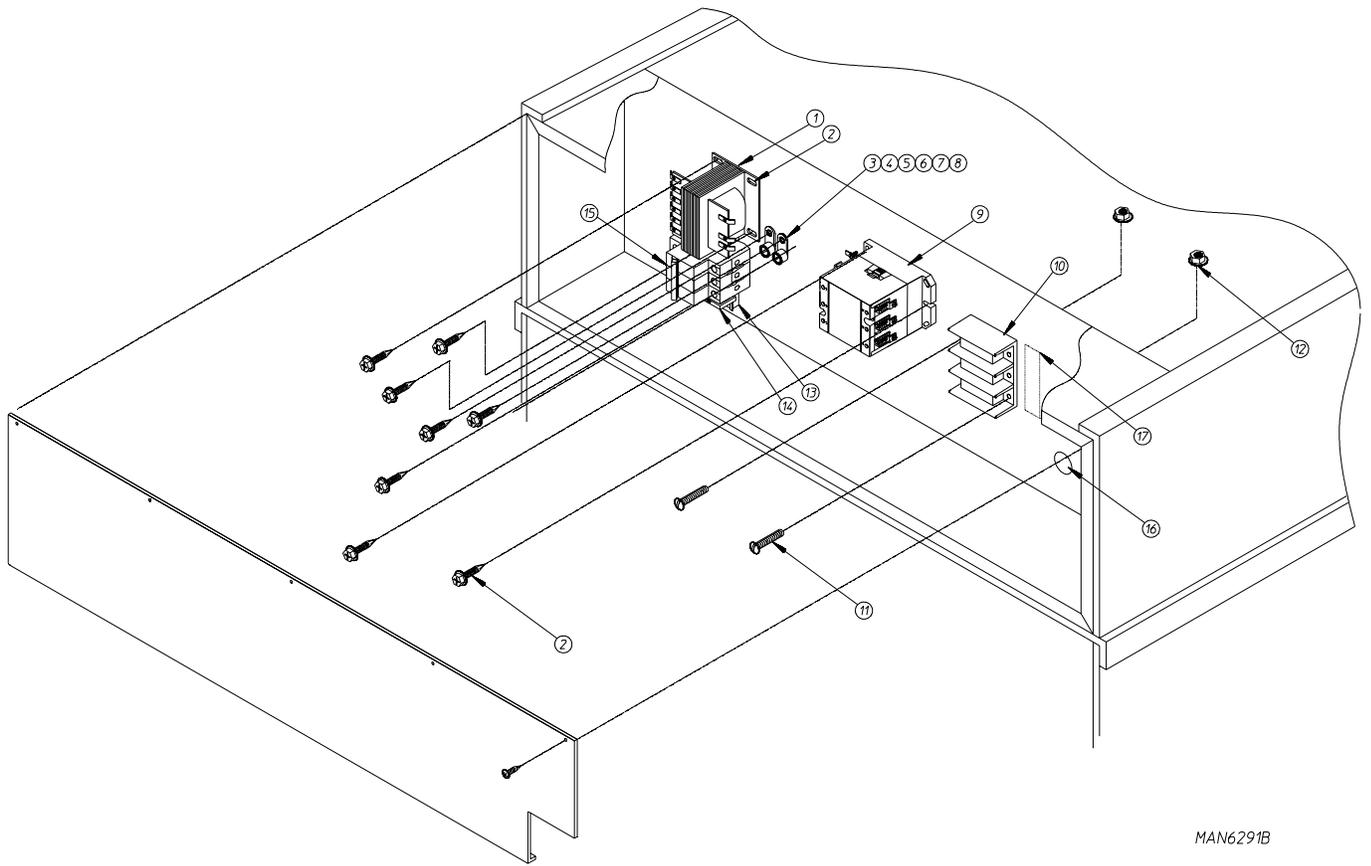

Illus. No.	Part No.	Qty.	Description
1	132004	1	Transformer
2	150309	10	#10-16 x 1/2" Hex Head TEK Crimptite Screw
3	121012	1	L-125 Ground Lug
4	121010	1	L-70 Ground Lug
5	150511	1	1/4-20 x 1" Tap Bolt
6	153018	1	1/4" Flat Washer
7	153007	1	1/4" Lock Washer
8	152002	1	1/4-20 Hex Nut
9	131362	1	120-amp 24 Volt Relay
10	120706	1	Power Distribution Block
11	150521	2	1/4-20 x 2" Carriage Bolt
12	152014	2	1/4-20 Free Spin Wash Nut
13	120768	3"	35 x 15mm Din Rail (sold by the inch)
14	120765	2	Din Rail End Stop
15	135499	1	25-amp / 3-Pole Circuit Breaker
16	121400	1	Universal Bushing
17	114518	1	Power Block Label

# Steam Damper Assembly

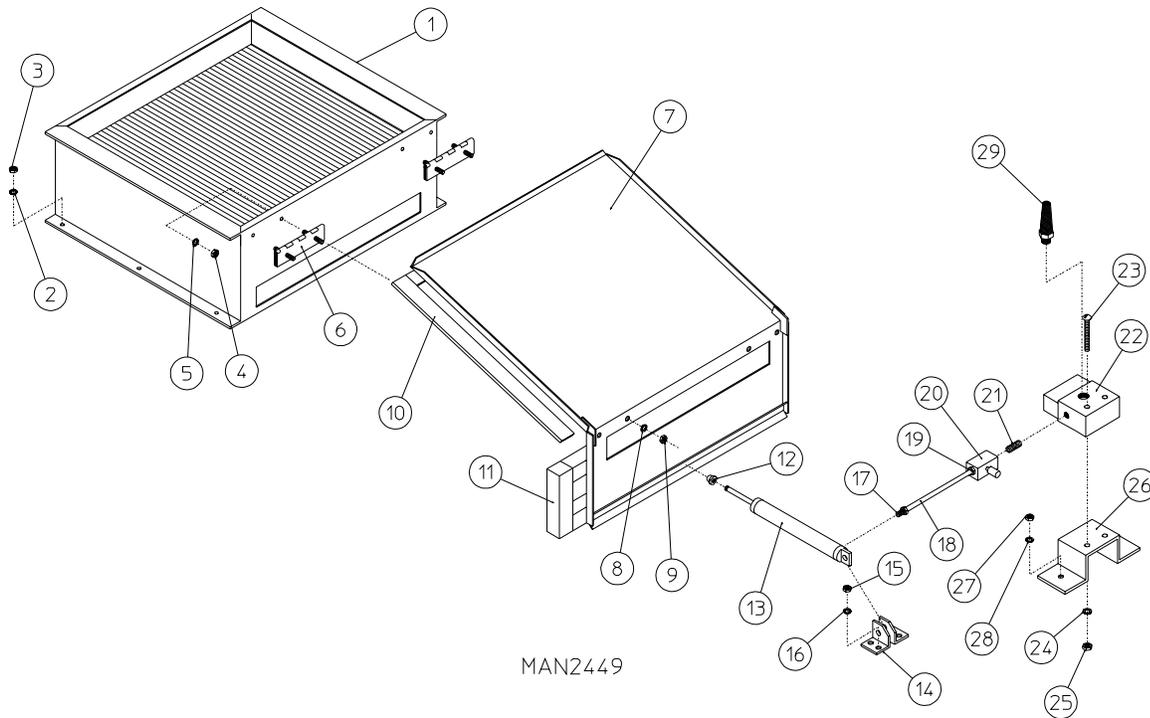

MAN2449

Illus. No.	Part No.	Qty.	Description
1	165012	1	Steam Coil Assembly
	165019	1	Steel Steam Coil Assembly
2	153002	6	5/16" Lock Washer
3	152004	6	5/16-18 Hex Nut
4	152002	4	1/4-20 Hex Nut
5	153007	4	1/4" Lock Washer
6	820321	2	Steam Damper Hinge Assembly
7	820320	1	Steam Damper Assembly (includes illus. nos. 7, 10, and 11)
8	153007	4	1/4" Lock Washer
9	152002	4	1/4-20 Hex Nut
10	115995	84	Steam Damper Gasket (sold by the inch)
11	102350	1	Steam Damper Foam (68-1/2" length)
12	151007	1	7/16-20 Stainless Steel Acorn Nut
13	100499	1	1-1/2" Bore x 3" Stroke Piston
14	100500	1	Piston Support Bracket
15	152002	4	1/4-20 Hex Nut
16	153007	4	1/4" Lock Washer
17	100472	1	1/4" x 1/8" Connector
18	143110	1	1/4" Tubing (sold by the foot)
19	100472	1	1/4" x 1/8" Connector
20	100496	1	1/8" Needle Valve
21	143238	1	1/8" Close Nipple
22	100498	1	3-Way Micro Valve – 24 VAC
23	150002	2	#6-32 x 1" Phillips Round Head Machine Screw
24	153010	2	#6 Star Washer
25	152000	2	#6-32 Hex Nut
26	330987	1	Micro Valve Support Bracket
27	152002	2	1/4-20 Hex Nut
28	153007	2	1/4" Lock Washer
29	100520	1	1/8" N.P.T. Silencer (muffler)

# Phase 7 Reversing Relay Panel Assembly

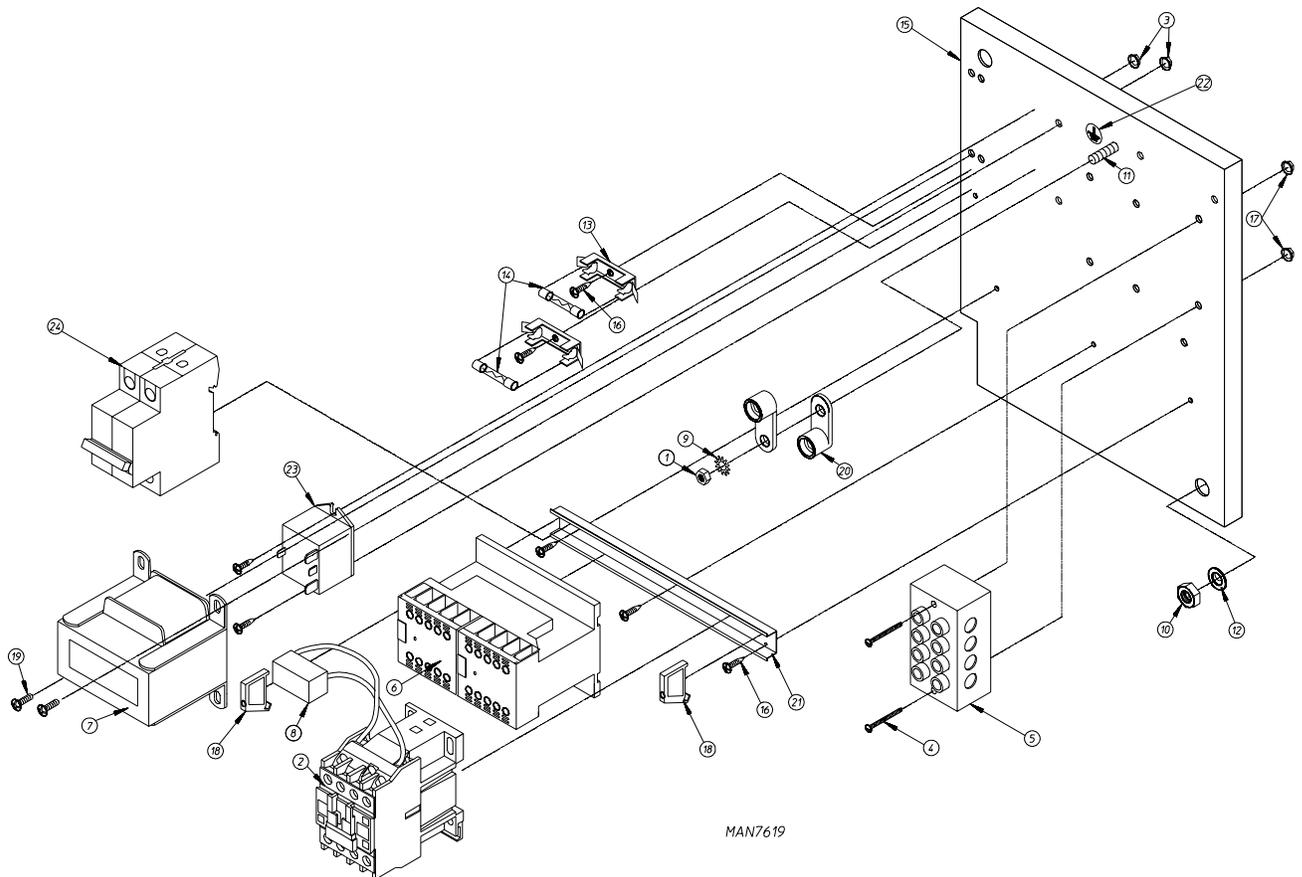

Illus. No.	Part No.	Qty.	Description
1	152002	1	1/4-20 Hex Nut
2	132445	1	3 hp Contactor
3	151001	2	#8-32 Pal Nut
4	150009	2	#6-32 x 1-1/2" Slotted Round Head Machine Screw
5	120701	1	4-Position Terminal Block
6	132497	1	Reversing Contactor
7	132070	1	208-240 Volt Transformer (for gas and steam models)
	132082	1	380-416 Volt Transformer (for gas and steam models)
	132067	1	460-480 Volt Transformer (for gas and steam models)
8	137015	1	Arc Suppressor Board
9	153021	1	1/4" Star Washer
10	152004	1	5/16-18 Hex Nut
11	153525	1	1/4-20 x 1" Self-Clinching Stud
12	153002	1	5/16" Lock Washer
13	136008	2	Fuse Holder
14	136048	2	3/4-amp (3AG) Slo-Blo Fuse (for 208-416 volt gas and steam models)
	136106	2	2-amp (3AG) Slo-Blo Fuse (for 208-240 volt electric models)
15	332346	1	Relay Panel
16	150301	3	#8-18 x 7/16" Phillips Head TEK Screw
17	151000	2	#6-32 Pal Nut
18	120765	2	End Stop
19	150108	2	#8-32 x 7/16" Phillips Pan Head Machine Screw
20	121010	2	L-70 Ground Lug
21	120768	8-1/4"	35 x 15mm Din Rail
22	112075	1	Ground Label
23	131932	1	24 VAC Relay (for electric models)
24	135501	1	2-Pole 1-amp Circuit Breaker (for 380-416 volt electric and all 480 volt models)

# Dual Timer Reversing Relay Mounting Panel Assembly

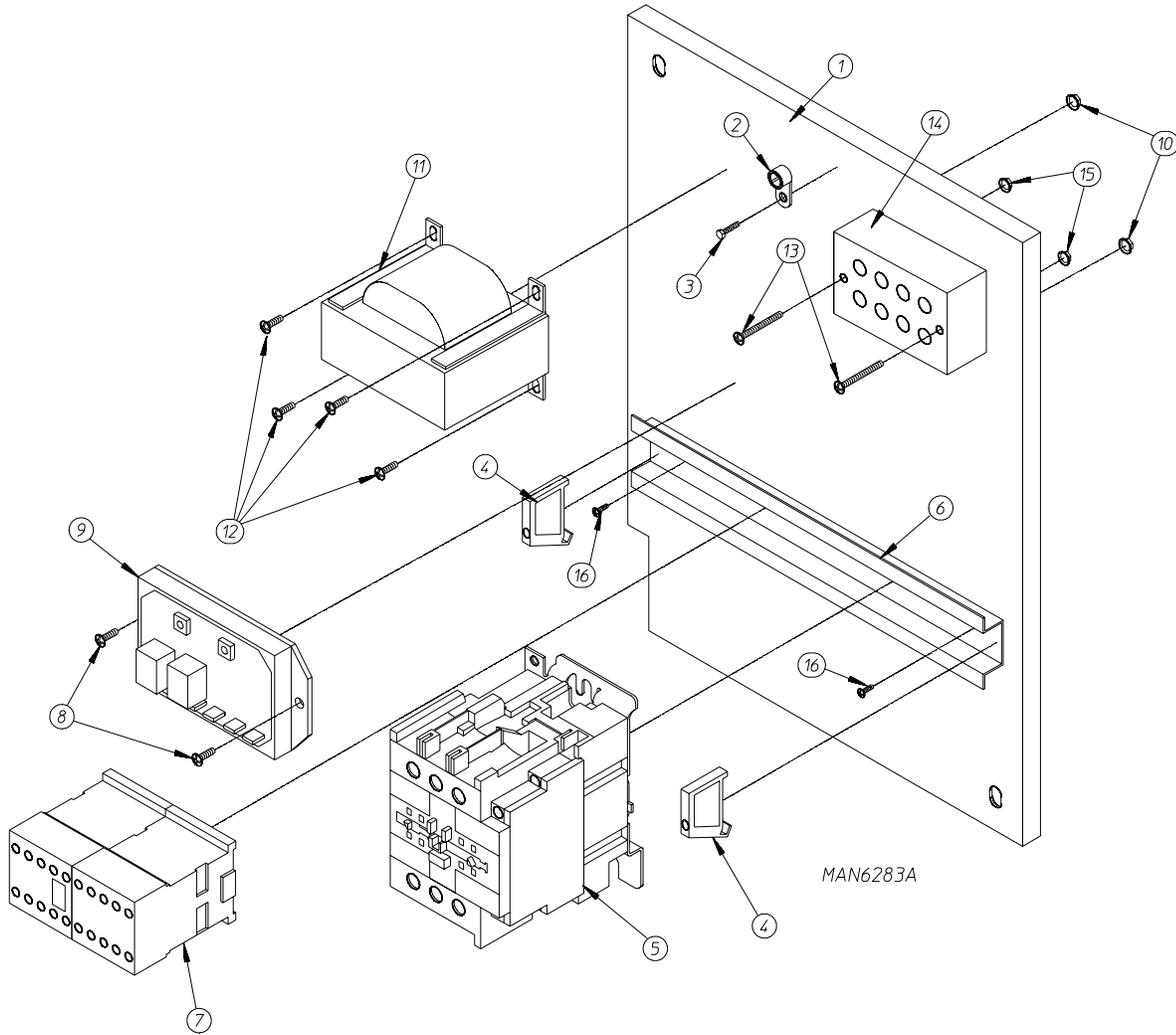

Illus. No.	Part No.	Qty.	Description
1	803632	1	Contactors / Relay Mounting Panel
2	121010	1	L-70 Ground Lug
3	150108	1	#8-32 x 1/2" Phillips Pan Head Machine Screw
4	120774	2	End Stop / Bracket
5	132445	1	3 hp Impellor (fan / blower) Contactor
6	120768	9"	Din Mounting Rail
7	132431	1	Reversing (impellor / blower / fan) Contactor – 24 VAC
8	150100	2	#8-32 x 1/2" Phillips Round Head Screw
9	132198	1	Reversing Timer (50/60 Hz) – 24 VAC
10	151001	2	#8-32 Pal Nut
11	132059	1	380 Volt Step Down Transformer (for gas and steam models)
	132062	1	416 Volt Step Down Transformer (for gas and steam models)
	132053	1	460 Volt Step Down Transformer (for gas and steam models)
12	150300	4	#10-16 x 1/2" Hex Washer TEK Screw
13	150009	2	#6-32 x 1-1/2" Phillips Round Head Machine Screw
14	120701	1	4-Position Power Distribution Block
15	151000	2	#6-32 Pal Nut
16	150309	2	#10-16 x 1/2" Hex Head TEK Crimpite Screw

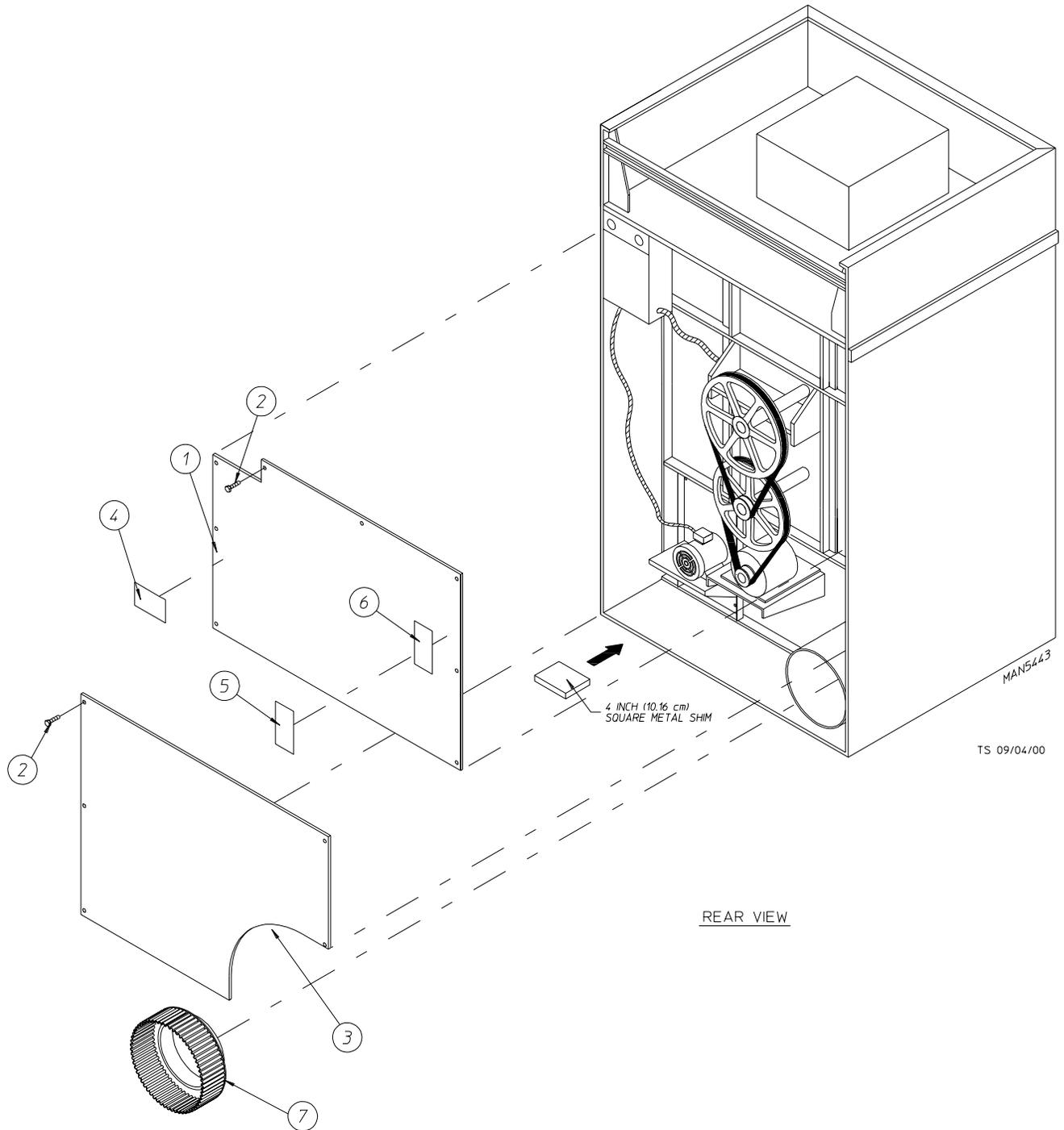

Illus. No.	Part No.	Qty.	Description
1	317242	1	Top Back Guard
2	150301	12	#8-18 x 7/16" Phillips Pan Head TEK Screw
3	317241	1	Lower Back Guard
4	112017	1	ADC Name and Address Label
5	112229	1	Installation Instructions Label
6	112519	1	Routine Maintenance Label
7	850185	1	12" to 14" Increaser Gas / Steam / Electric

# Fire Suppression System Solenoid Assembly

For Models Mfd. as of September 23, 2004

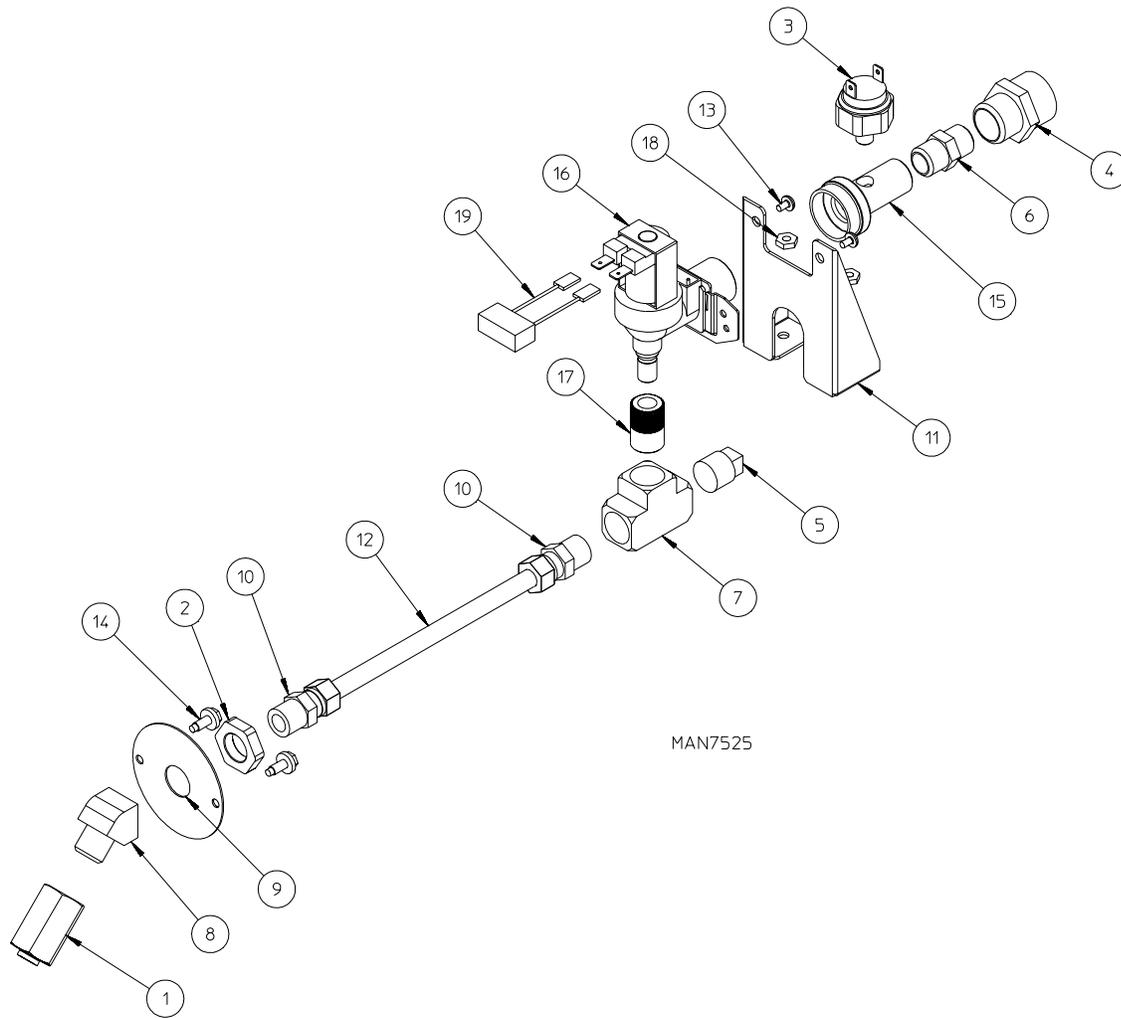

Illus. No.	Part No.	Qty.	Description
1	143581	1	Fire Suppression System 3 GPM 3/8" N.P.T. Spray Nozzle
2	143303	1	3/8" N.P.T. Brass Lock Nut
3	136987	1	Water Jet Pressure Switch
4	143025	1	3/4"-11.5 NH x 3/8" N.P.T. Nylon Hose Adapter
5	143251	1	3/8" M.P.T. Brass Plug
6	182579	1	3/8" M.P.T. x 3/8" M.P.T. Brass Hex Nipple
7	143220	1	3/8" F.P.T. Brass Tee
8	143301	1	3/8" Brass 45° Street Elbow
9	311588	1	Fire Suppression System Sprinkler Head Mounting Plate
10	143208	2	3/8" Comp x 3/8" M.P.T. Brass Connector
11	311587	1	Medium Dryer Fire Suppression System Valve Bracket
12	143108	1	20" Stainless Steel Flex Hose with 3/8" Compression
13	154338	2	M4 x 6mm Phillips Head Slotted Machine Screw
14	150309	2	#10-16 x 1/2" Hex Head TEK Crimp Tite
15	143182	1	3/4" GHT x 1/8" x 3/8" N.P.T. Brass Tee
16	165119	1	Fire Suppression System Water Inlet Valve
17	143183	1	7/16-20 x 3/8" N.P.T. Brass Adapter 2
18	152001	2	#8-32 3/8" Hex Nut
19	824081	1	R.C. Network Assembly

# Fire Suppression System Solenoid Assembly

For Models Mfd. prior to September 23, 2004

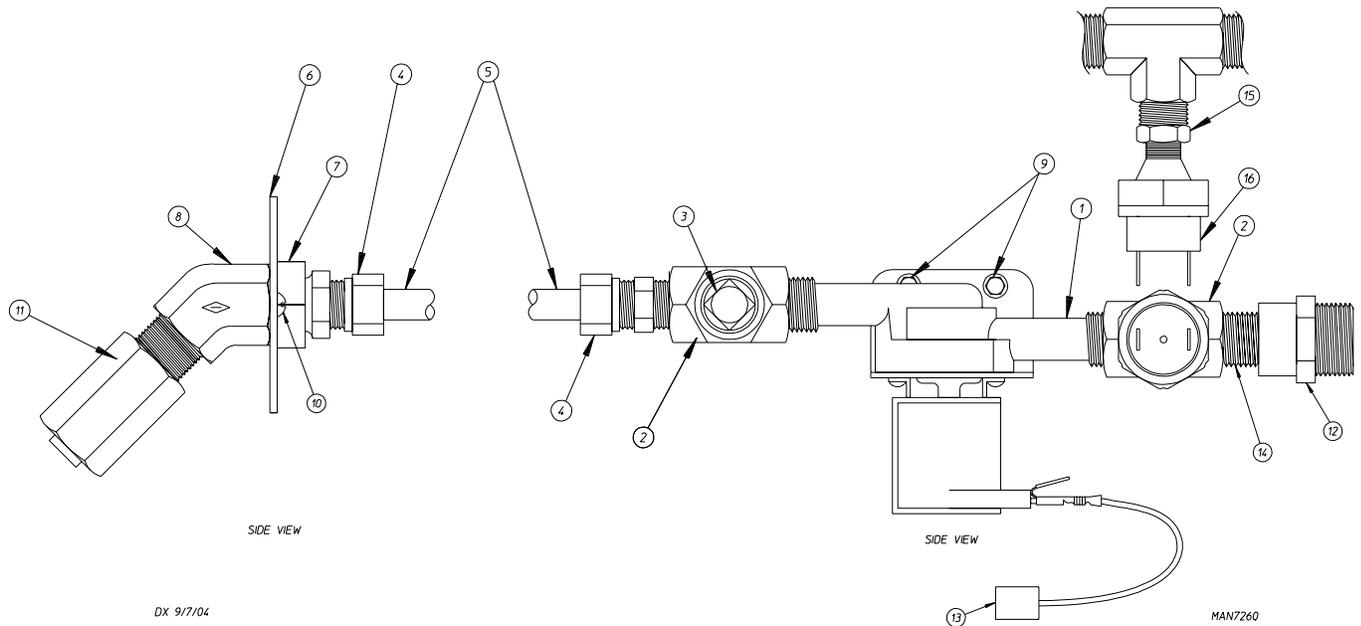

Illus. No.	Part No.	Qty.	Description
1	165114	1	Solenoid Valve 24 VAC 50/60 Hz
2	143220	2	3/8" F.P.T. Brass Tee
3	143251	1	3/8" M.P.T. Brass Plug
4	143208	2	3/8" Comp x 3/8" M.P.T. Brass Connector
5	143108	1	20" Long Stainless Steel Flexible Tubing
6	311588	1	Sprinkler Head Mounting Plate
7	143303	1	3/8" N.P.T. Brass Lock Nut
8	143301	1	3/8" Brass 45° Elbow
9	152001	2	#8-32 x 3/8" OD Hex Nut
10	150430	2	#10 x 1/2" Self-Drilling Screw
11	143581	1	3 GPM 3/8" F.P.T. Spray Nozzle
12	143025	1	3/8" N.P.T. Nylon Hose Adapter
13	824081	1	RC Network Assembly
14	143315	1	3/8" x 1/8" Bushing
15	182579	1	3/8" Hex Nipple (for models mfd. as of December 1, 2003)
16	136987	1	Pressure Switch (for models mfd. as of December 1, 2003)

# S.A.F.E. Temperature Probe Assembly

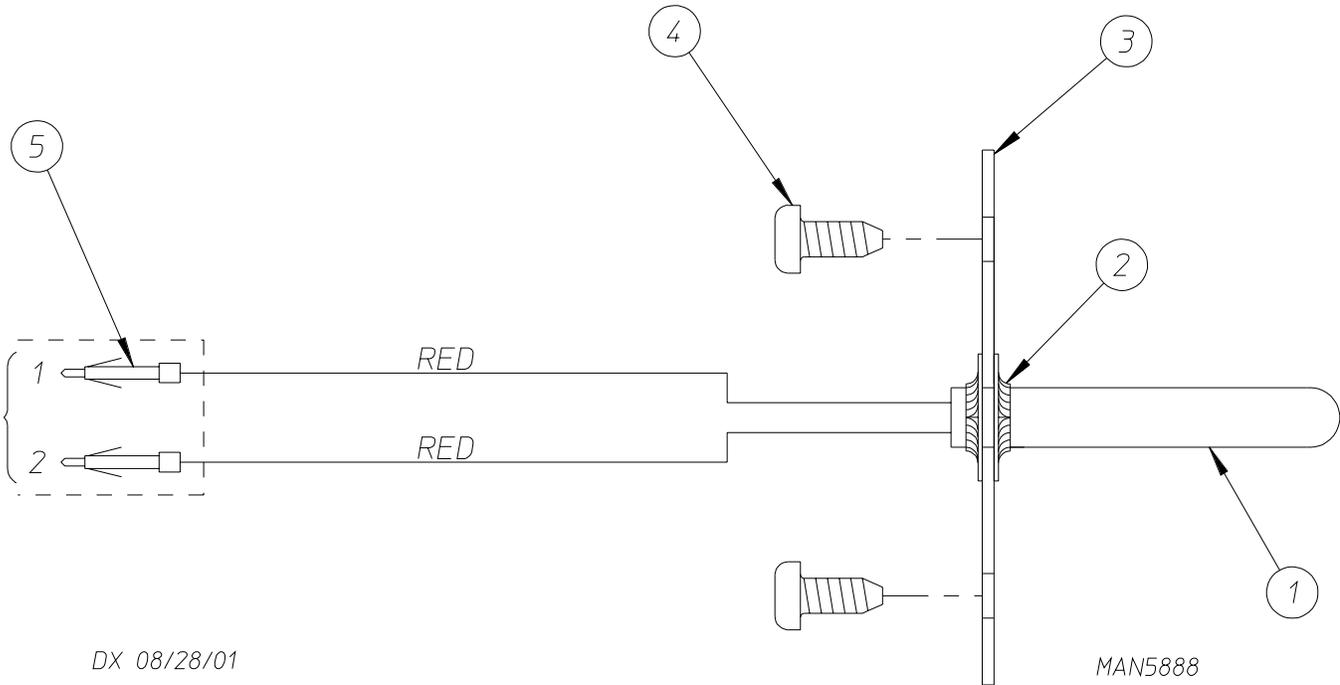

Illus. No.	Part No.	Qty.	Description
1	822752	1	Sensor Activated Fire Extinguishing System Temperature Probe Assembly (includes illus. nos. 1 through 5)
2	154007	2	Push-On Fastener
3	390390	1	Sensor Bracket
4	150301	2	#8-18 x 7/16" Phillips Pan Head TEK Screw
5	122647	1	Connector
	122700	2	Pin

<u>Part No.</u>	<u>Description</u>
112280	"Clean Lint Screen" Label
114001	"CAUTION – Exhaust / Lint Screen" Label
114006	"WARNING – Fire Hazards" Label
114043	"Phase 7 OPL Program Location Summary" Label
120100	3/8" Straight (BX) Connector
120300	3/8" x 45° (BX) Connector
120400	3/8" Red Jacket (BX) Insulator
120500	3/8" Jiffy Clip (BX retainer clip)
120600	3/8" Greenfield (BX)
120800	1/4" In-Line Connector
120802	Red Butt Connector
120902	#74B Wire Nut
120903	Closed End Connector
121014	1/4" Insulated (female) Terminal
121499	5-1/2" Wire Tie
121500	8" Harness Tie
121503	Harness Tie Mounting Clip
122804	Manometer (water column test gauge)
401010	#847 Adhesive for Felt Collar
404502	White Brush-In-Cap Bottle Touch-Up Paint (0.6 oz. bottle)

