



AD-170
Parts Manual
Phase 4
(for models mfd. prior to 1992)

American Dryer Corporation
88 Currant Road
Fall River, MA 02720-4781
Telephone: (508) 678-9000 / Fax: (508) 678-9447
E-mail: techsupport@amdry.com

www.amdry.com

Retain This Manual In A Safe Place For Future Reference

American Dryer Corporation products embody advanced concepts in engineering, design, and safety. If this product is properly maintained, it will provide many years of safe, efficient, and trouble free operation.

ONLY qualified technicians should service this equipment.

OBSERVE ALL SAFETY PRECAUTIONS displayed on the equipment or specified in the installation manual included with the dryer.

The following “**FOR YOUR SAFETY**” caution must be posted near the dryer in a prominent location.

FOR YOUR SAFETY

Do not store or use gasoline or other flammable vapors and liquids in the vicinity of this or any other appliance.

POUR VOTRE SÉCURITÉ

Ne pas entreposer ni utiliser d'essence ni d'autres vapeurs ou liquides inflammables à proximité de cet appareil ou de tout autre appareil.

We have tried to make this manual as complete as possible and hope you will find it useful. ADC reserves the right to make changes from time to time, without notice or obligation, in prices, specifications, colors, and material, and to change or discontinue models.

Important

For your convenience, log the following information:

DATE OF PURCHASE _____ MODEL NO. **AD-170**
RESELLER'S NAME _____
Serial Number(s) _____

Replacement parts can be obtained from your reseller or the ADC factory. When ordering replacement parts from the factory, you can FAX your order to ADC at (508) 678-9447 or telephone your order directly to the ADC Parts Department at (508) 678-9000. Please specify the dryer model number and serial number in addition to the description and part number, so that your order is processed accurately and promptly.

The illustrations on the following pages may not depict your particular dryer exactly. The illustrations are a composite of the various dryer models. Be sure to check the descriptions of the parts thoroughly before ordering.

“IMPORTANT NOTE TO PURCHASER”

Information must be obtained from your local gas supplier on the instructions to be followed if the user smells gas. These instructions must be posted in a prominent location near the dryer.

Table of Contents

Control Door Assembly	4
Microprocessor Control Panel Assembly	5
Control Box Assembly	6
Front Panel / Main Door Assemblies	7
Main Door Switch Assembly	8
Drop Lint Door Assembly	9
Lint Drawer / Lint Drawer Switch Box Assemblies	10
Temperature Sensor Bracket Assembly	11
Tumbler / Support Assemblies	12
Tumbler Bearing Mount Assembly	13
Idler Bearing Mount Assembly	14
Totally Enclosed, Fan-Cooled Basket Motor Mount Assembly	16
Blower Motor Mount Assembly for 60 Hz Gas Only	17
Blower Motor, Fan, and Shaft Assembly for 60 Hz Steam and 50 Hz Gas Models Only	18
Blower Motor, Fan, and Shaft Assembly for 50 Hz Steam Only	20
Direct Spark Ignition Burner Assembly for Gas Models Only	22
Direct Spark Ignition Module Mount Assembly	24
Sail Switch Assembly	25
Steam Damper Assembly	26
Microprocessor Reversing Control Box Assembly for Models Mfd. as of June 21, 1991	27
Microprocessor Reversing Control Box Assembly for Models Mfd. prior to June 21, 1991	28
Back Guard Assembly / Stepdown Transformer	29
Additional Parts Available	30

Control Door Assembly

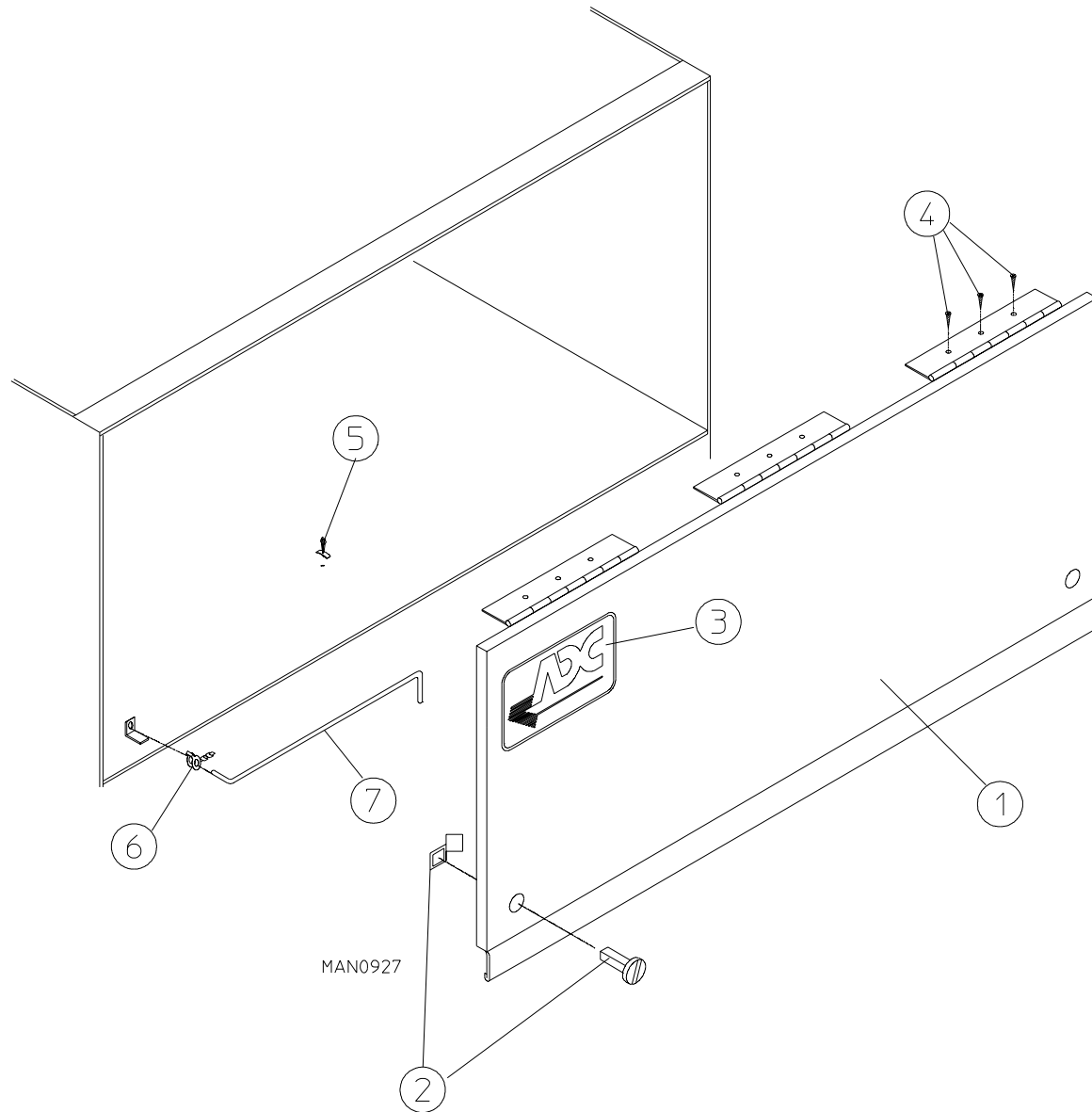

Illus. No.	Part No.	Qty.	Description
1	820944*	1	Control Door (20" height) Assembly (for gas models only)
	820963*	1	Short Control Door (13" height) Assembly (for steam models mfd. as of June 1, 1991)
	820944*	1	Control Door (20" height) Assembly (for steam models mfd. prior to June 1, 1991)
2	160005	2	Spring Turn Latch (2-piece)
3	112360	1	ADC Logo Only
	870011	1	Logo Double Tape Kit
4	150415	9	#10-16 x 1/2" Phillips Crimptite Screw
5	102600	1	Control Door Support Rod Catch
6	102601	1	Control Door Rod Retainer Clip
7	102505	1	Control Door Support Rod

* Specify color when ordering.

Microprocessor Control Panel Assembly

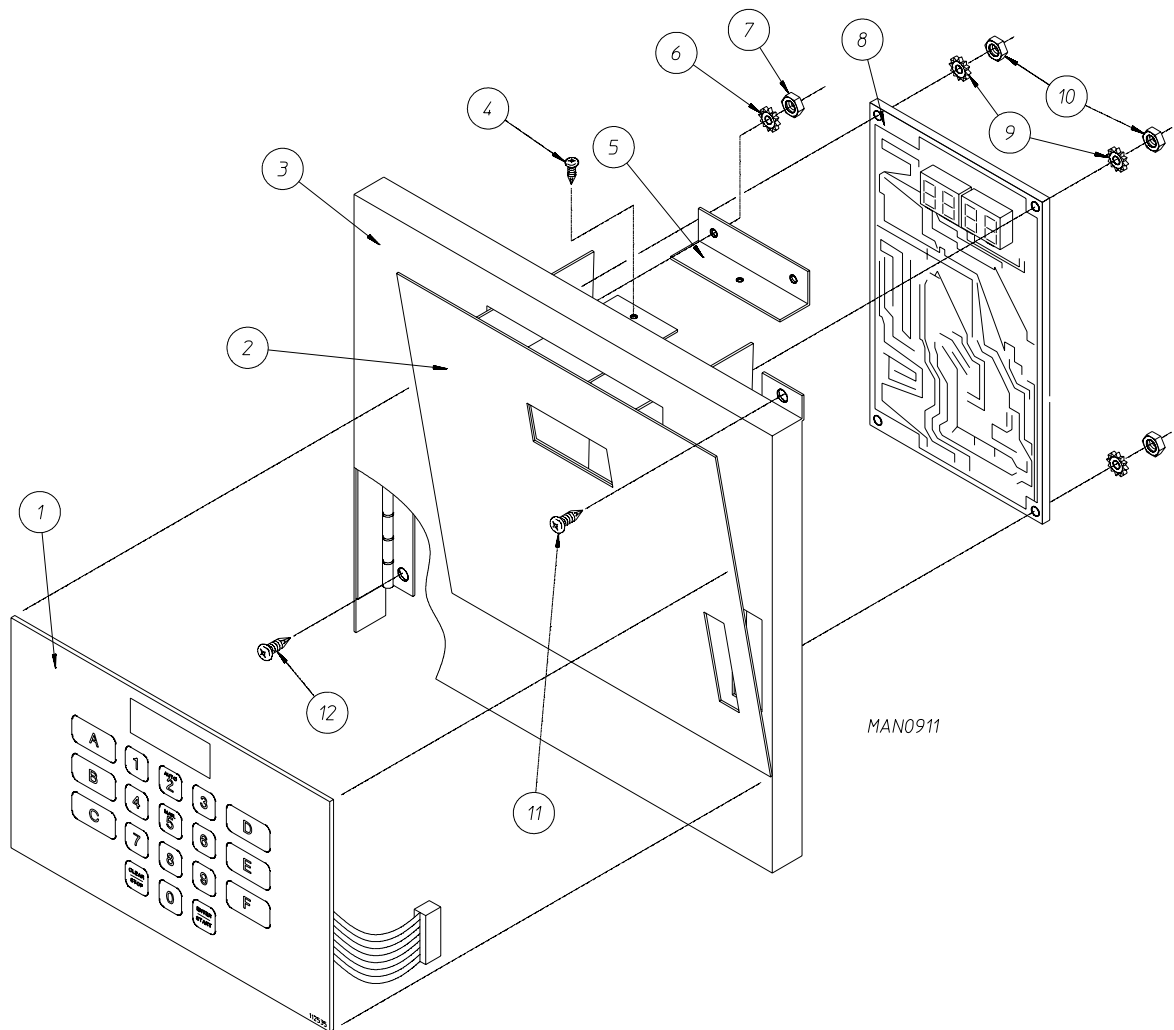

Illus. No.	Part No.	Qty.	Description
1	112535	1	Non-Coin English Keypad Label Assembly
	112276	1	Non-Coin Stick-On Labels (English Only) ... Not Illustrated
	112275	1	Non-Coin Stick-On Labels (Spanish, Italian, and Hebrew) ... Not Illustrated
	112277	1	3-Language Non-Coin Stick-On Labels (English, Spanish, and Hebrew) ... Not Illustrated
	112278	1	5-Language Non-Coin Stick-On Labels (Italian, Dutch, French, German, and Chinese) ... Not Illustrated
2	820935	1	Swing Out Computer Drawer
3	820912	1	Control Box Door
4	150000	1	#6-32 x 1/4" Machine Screw
5	332200	1	Computer Drawer Angle
6	153012	2	#8 Star Washer
7	152001	2	#8-32 Hex Nut
8	137127	1	Phase 4 Non-Coin Reversing Controller
	137128	1	Phase 4 Non-Coin Reversing Controller with Battery Clip
9	153012	4	#8 Star Washer
10	152001	4	#8-32 Hex Nut
11	150000	1	#6-32 x 1/4" Machine Screw
12	150000	3	#6-32 x 1/4" Machine Screw

IMPORTANT: Check label on computer chip to verify correct part number.

Control Box Assembly

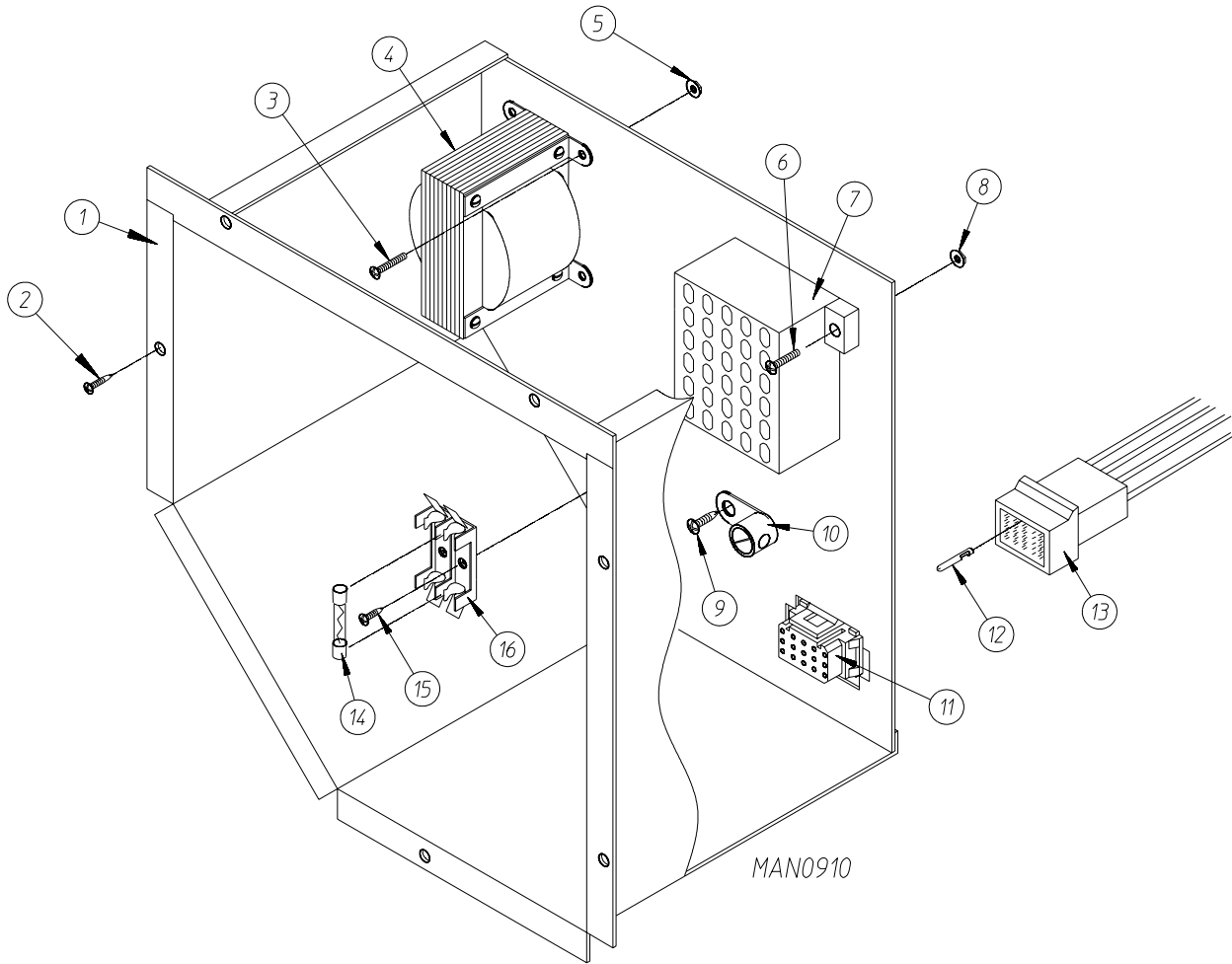

Illus. No.	Part No.	Qty.	Description
1	820940	1	Control Box Assembly Complete (includes illus. nos. 1 through 11 and 14 through 16)
2	150301	6	#8-32 x 7/16" Phillips TEK Screw
3	150100	2	#8-32 x 1/2" Machine Screw
4	141403	1	24VAC Transformer
5	151001	2	#8-32 Pal Nut
6	150002	2	#6-32 x 1" Machine Screw
7	120715	1	30-Position Terminal Block
8	151000	2	#6-32 Pal Nut
9	150415	1	#10-16 x 1/2" Phillips Crimpite Screw
10	121010	1	L-70 Ground Lug
11	122626	1	15-Pin Socket Connector
12	122704	14	Pin Terminal
13	122625	1	15-Pin Connector
14	136057	*	1/2-Amp (Slo-Blo) Fuse
15	150301	*	#8-32 x 7/16" Phillips TEK Screw
16	136008	*	Fuse Block / Strip
—	122800	1	Microprocessor (female) Pin Extraction Tool
—	122801	1	Pin / Socket Extraction Tool

* As required.

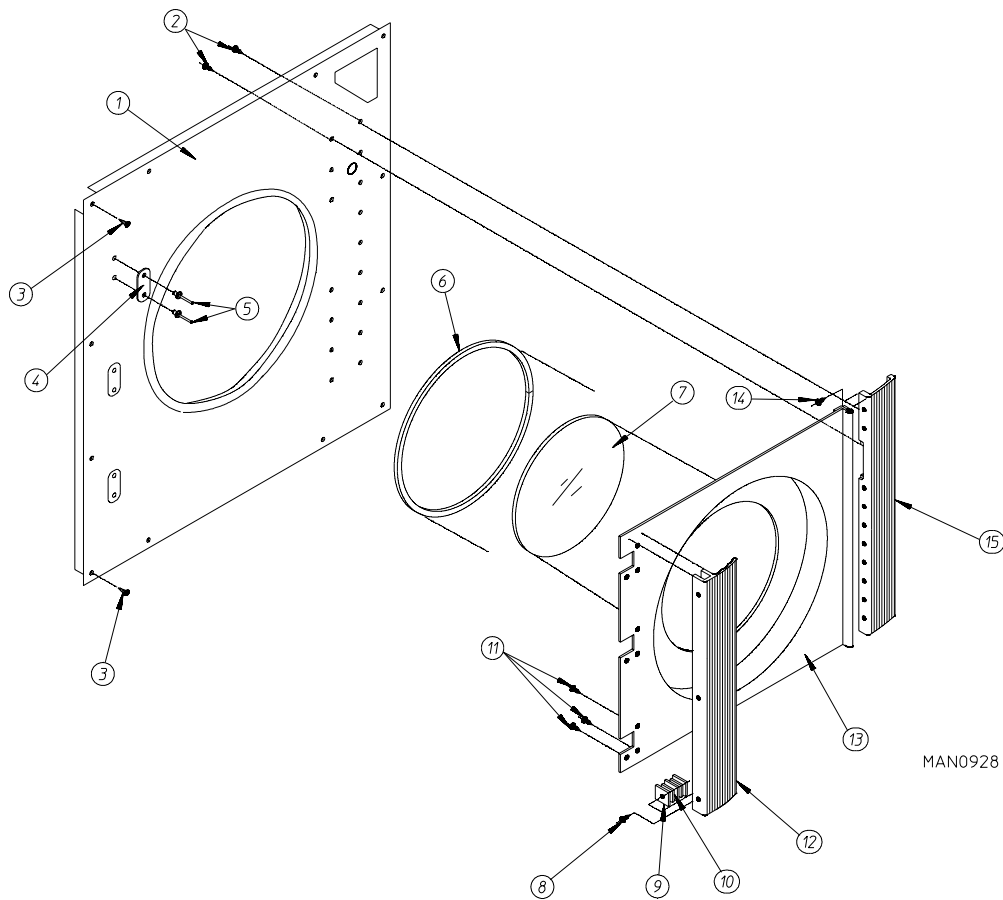

MAN0928

Illus. No.	Part No.	Qty.	Description
1	820929	1	Right-Hand Front Panel Assembly (includes illus. nos. 1, 4, and 5)
2	150415	15	#10-24 x 5/8" Phillips Crimptite Screw
3	150412	12	#10-16 x 1/2" Phillips Crimptite Screw
4	170340	3	3-1/2" Stainless Steel Striker Pad
5	154200	6	5/32" Pop Rivet
6	102308	1	Door Gasket Only (94" length)
7	102210	1	20-7/16" Door Glass
	170725	1	Glass and Gasket Adhesive (2.8 oz. tube)
8	150401	3	#10-24 x 1-1/4" Phillips Taptite Screw
9	306801	6	Magnet Keeper
10	102100	6	1" x 1" x 1/4" Main Door Magnet
11	150415	9	#10-16 x 1/2" Phillips Crimptite Screw
12	170201	1	35" Silver Main Door Handle
	180150	1	35" Gray Main Door Handle
13	800110	1	Main Door Assembly Complete with Silver Handle (includes illus. nos. 6 through 13)
	800127	1	Main Door Assembly Complete with Gray Handle (includes illus. nos. 6 through 13)
	800122*	1	Main Door Assembly with Glass and Gasket Only (includes illus. nos. 6, 7, and 13)
14	150430	11	#10 x 1/2" Phillips Self-Drilling Screw
15	170210	1	35" Silver Main Door Hinge Block
	180155	1	35" Gray Main Door Hinge Block

* Specify color when ordering.

Main Door Switch Assembly

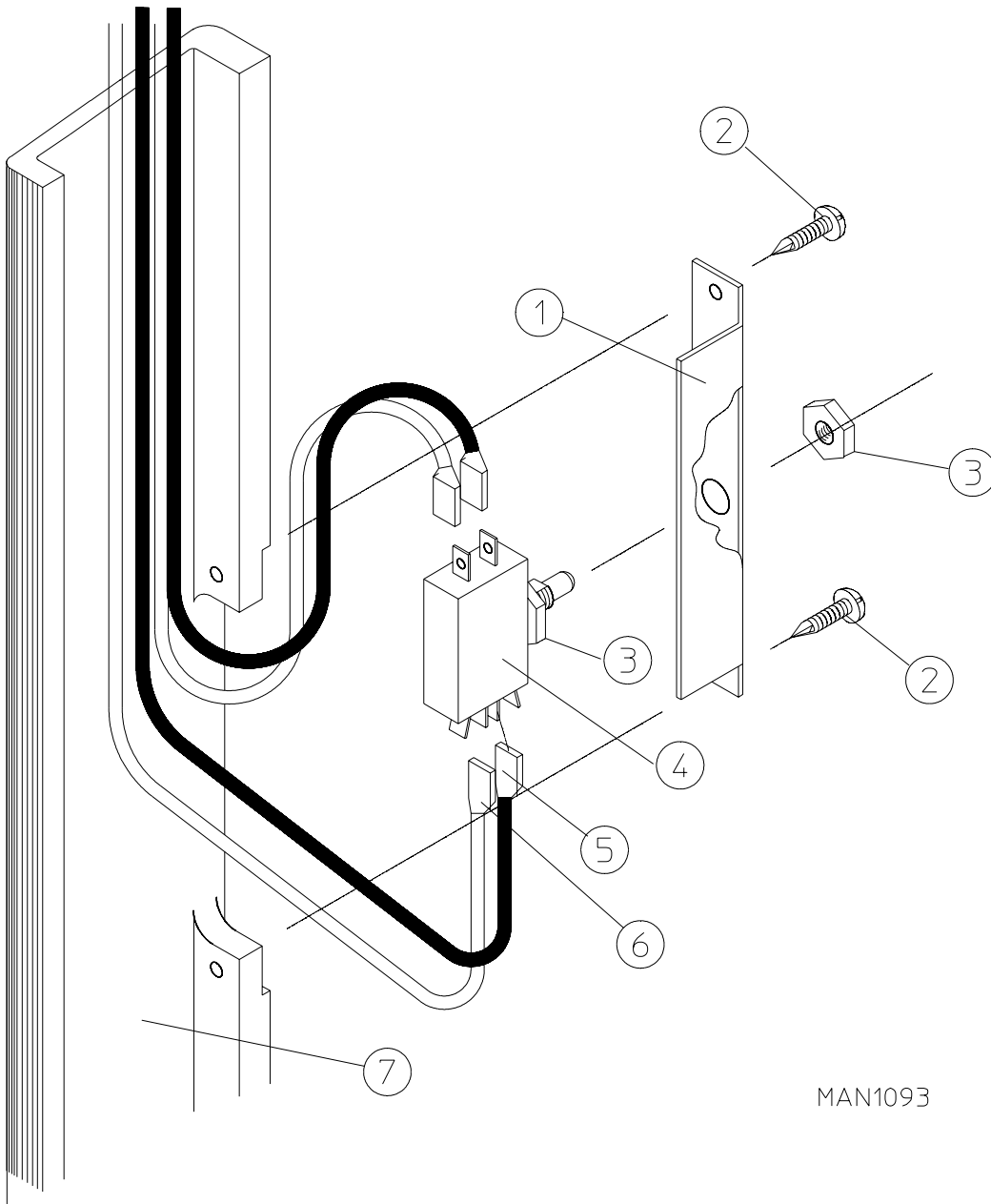

MAN1093

<u>Illus. No.</u>	<u>Part No.</u>	<u>Qty.</u>	<u>Description</u>
1	313208	1	Door Switch Bracket
2	150415	2	#10-16 x 1/2" Phillips Crimptite Screw
3	152003	2	3/8-32 x 1/2" x 1/16" Door Switch Nut
4	137006	1	Door Switch
5	121028	2	1/4" x .032 Insulated Terminal
6	121027	2	3/16" x .032 Insulated Terminal
7	170210	1	35" Silver Main Door Hinge Block
	180155	1	35" Gray Main Door Hinge Block

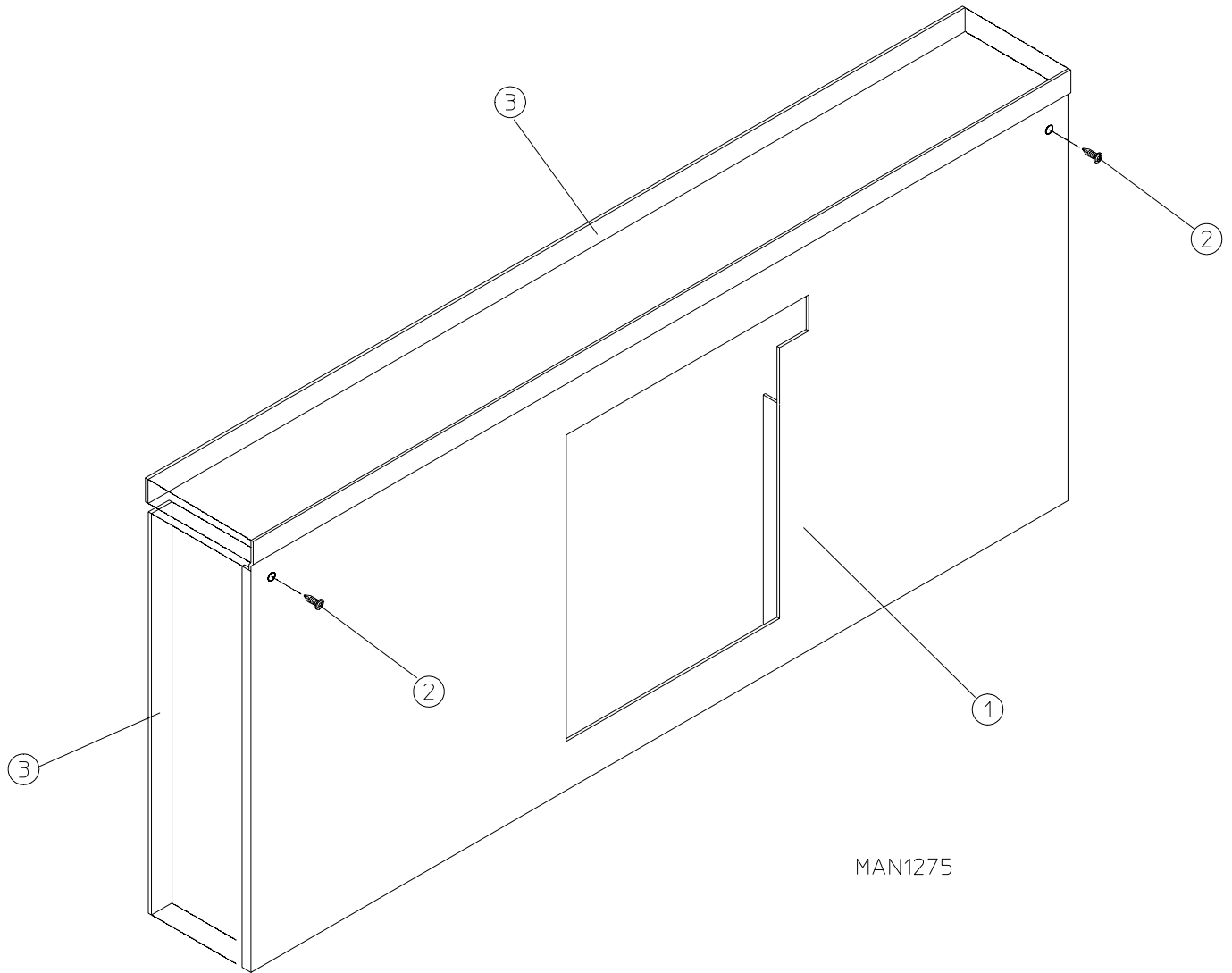

Illus. No.	Part No.	Qty.	Description
1*	820945	1	Drop Lint Door Assembly (includes illus. nos. 1 and 3)
2	150415	3	#10-16 x 1/2" Phillips Crimptite Screw
3	117602	6	Noise Suppressor Tape (sold by the foot)

* Specify color when ordering.

Lint Drawer / Lint Drawer Switch Box Assemblies

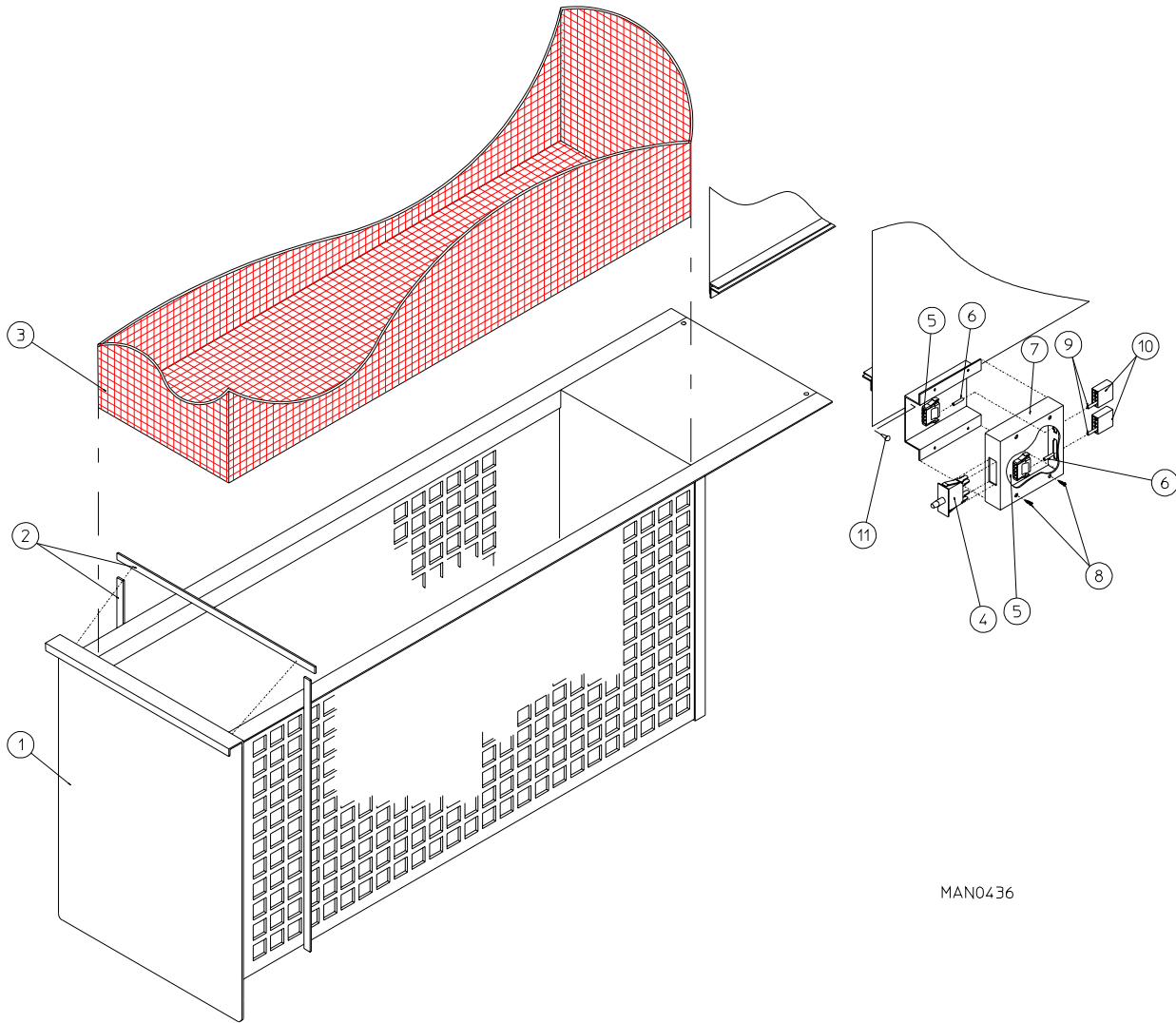

MAN0436

Illus. No.	Part No.	Qty.	Description
1*	820955	1	Lint Drawer Assembly Complete (includes illus. nos. 1 and 2)
2	117602	5	Noise Suppressor Tape (sold by the foot)
3	820925	1	Lint Screen Assembly
4	122115	1	Lint Drawer Switch
5	122605	2	4-Pin Socket Connector
6	122701	8	Socket Terminal
	122801	1	Pin / Socket Extraction Tool
7	800261	1	Lint Drawer Switch Box Assembly Complete (includes illus. nos. 4 through 7)
	304034	1	Lint Drawer Switch Box Only
8	150301	4	#8-18 x 7/16" Phillips Pan Head TEK Screw
9	122700	8	Pin Terminal
10	122604	2	4-Pin Connector
11	150301	2	#8-18 x 7/16" Phillips Pan Head TEK Screw

* Specify color when ordering.

Temperature Sensor Bracket Assembly

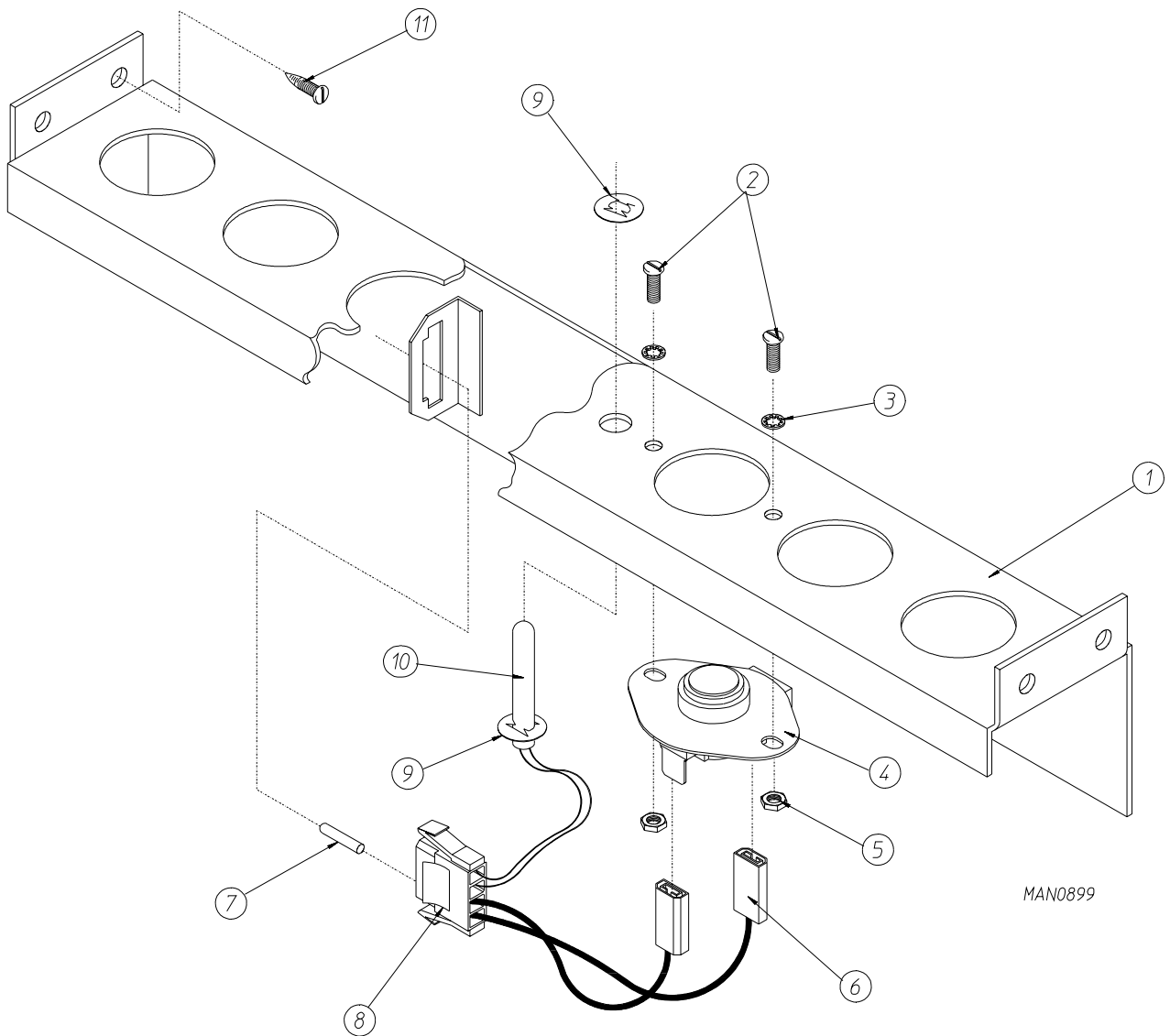

MAN0899

Illus. No.	Part No.	Qty.	Description
1	820967	1	Sensor Bracket Assembly
	820968	1	Sensor Bracket Assembly Complete (includes illus. nos. 1 through 10)
2	150000	2	#6-32 x 1/4" Slotted Round Head Machine Screw
3	153010	2	#6 Star Washer
4	130112	1	L-225 Thermostat
5	152000	2	#6-32 Hex Nut
6	121028	2	1/4" x .032 Insulated Terminal
7	122701	4	Socket
8	122605	1	4-Pin Socket Connector (female)
9	154007	2	1/4" Push-On Fastener
10	880251	1	1/4" Temperature Sensor Probe
11	150301	4	#8-18 x 7/16" Phillips Pan Head TEK Screw

Tumbler / Support Assemblies

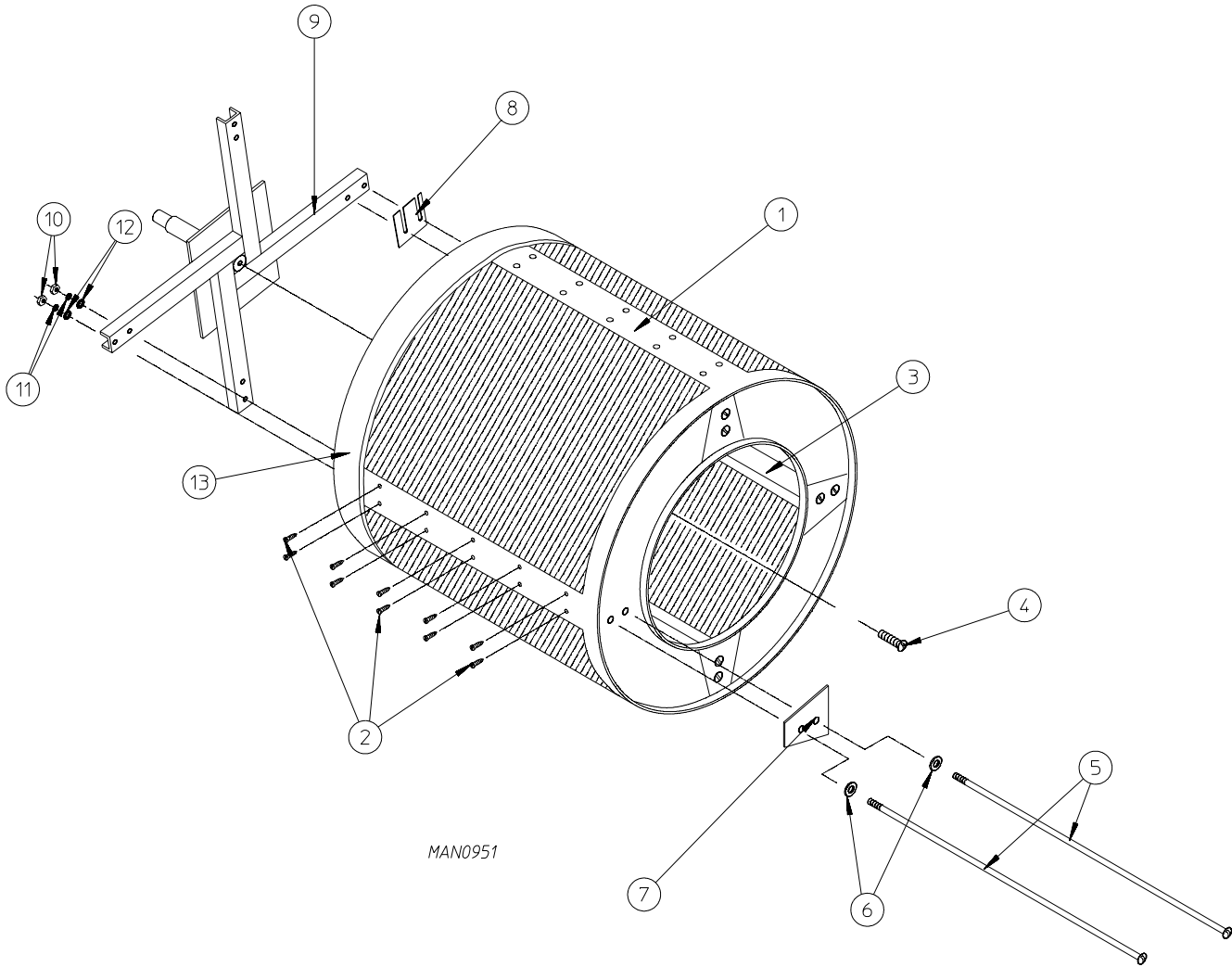

Illus. No.	Part No.	Qty.	Description
1	820979*	1	Tumbler Only without Felt Collar
	820927	1	Tumbler and Support Assembly Complete (includes illus. nos. 1 through 13)
2	150415	64	#10-16 x 1/2" Phillips Crimpite Screw
3	332140	4	Tumbler Rib
4	150500	1	5/16-18 x 3/4" Socket Button Head Screw
5	100908	12	7/16-14 x 44" Tie Rod
6	153014	12	7/16" Flat Washer
7	332139	4	Tumbler Reinforcing Plate
8	332177	**	Tumbler Shim
9	820909	1	Tumbler Support
10	152009	12	7/16-14 Hex Nut
11	153013	12	7/16" Lock Washer
12	153014	12	7/16" Flat Washer
13	116007	1	Felt Collar
—	401010	1	#847 Adhesive for Felt Collar (5.0 oz. tube)

* Felt collar not included and must be ordered separately.

** As required.

Tumbler Bearing Mount Assembly

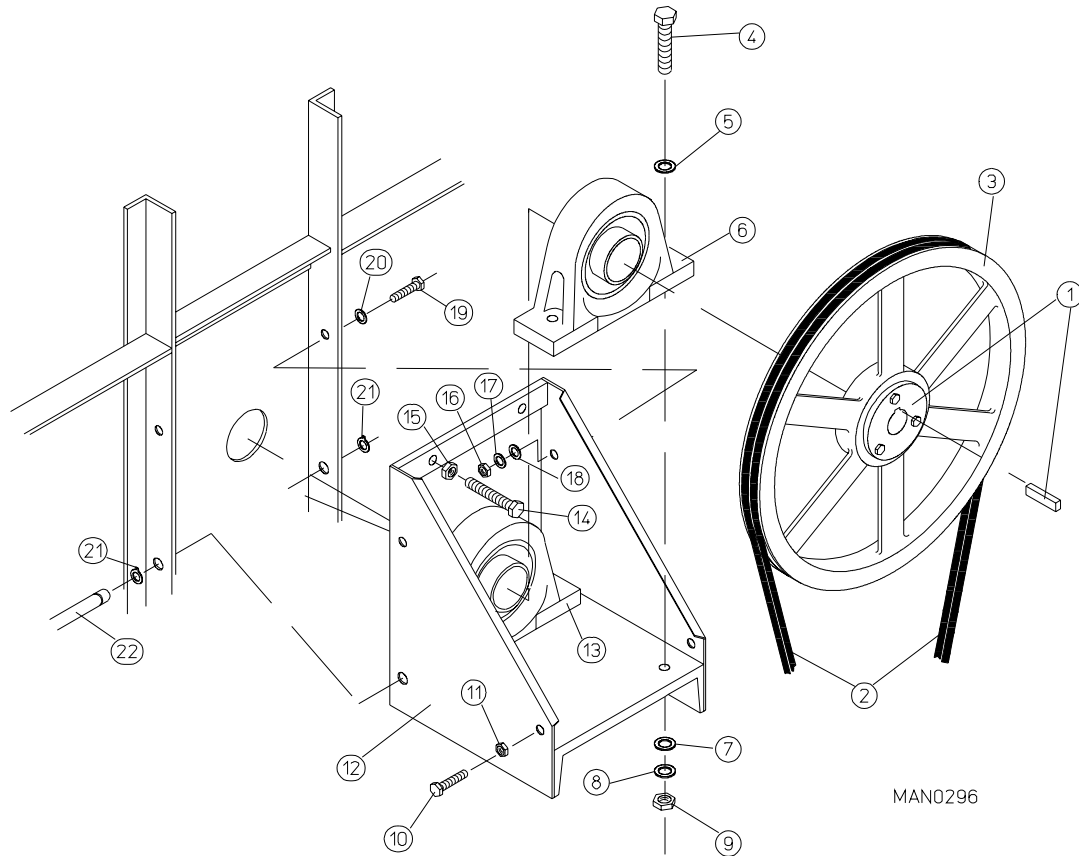

Illus. No.	Part No.	Qty.	Description
1	101137	1	2-1/4" SFX Bushing
2*	100137	2	AB91 V-Belt
3	101182	1	25" Basket Pulley
4	150602	4	5/8-11 x 3" Hex Head Machine Bolt
5	153016	4	5/8" Flat Washer
6	100223	1	3-1/8" Pillow Block Bearing
7	153016	4	5/8" Flat Washer
8	153015	4	5/8" Lock Washer
9	152010	4	5/8-11 Hex Nut
10	150600	2	3/8-16 x 1-1/2" Hex Head Machine Bolt
11	152005	2	3/8-16 Hex Nut
12	820910	1	Tumbler Bearing Mount
13	100223	1	3-1/8" Pillow Block Bearing
14	150603	2	1/2-13 x 3" Square Head Machine Bolt
15	152011	2	1/2-13 Hex Nut
16	152005	2	3/8-16 Hex Nut
17	153005	2	3/8" Lock Washer
18	153004	4	3/8" Flat Washer
19	150600	2	3/8-16 x 1-1/2" Hex Head Machine Bolt
20	153004	2	3/8" Flat Washer
21	100801	2	5/8" Retaining Ring
22	332153	1	5/8" Hinge Pin

* Replace in matched sets (both belts).

Idler Bearing Mount Assembly

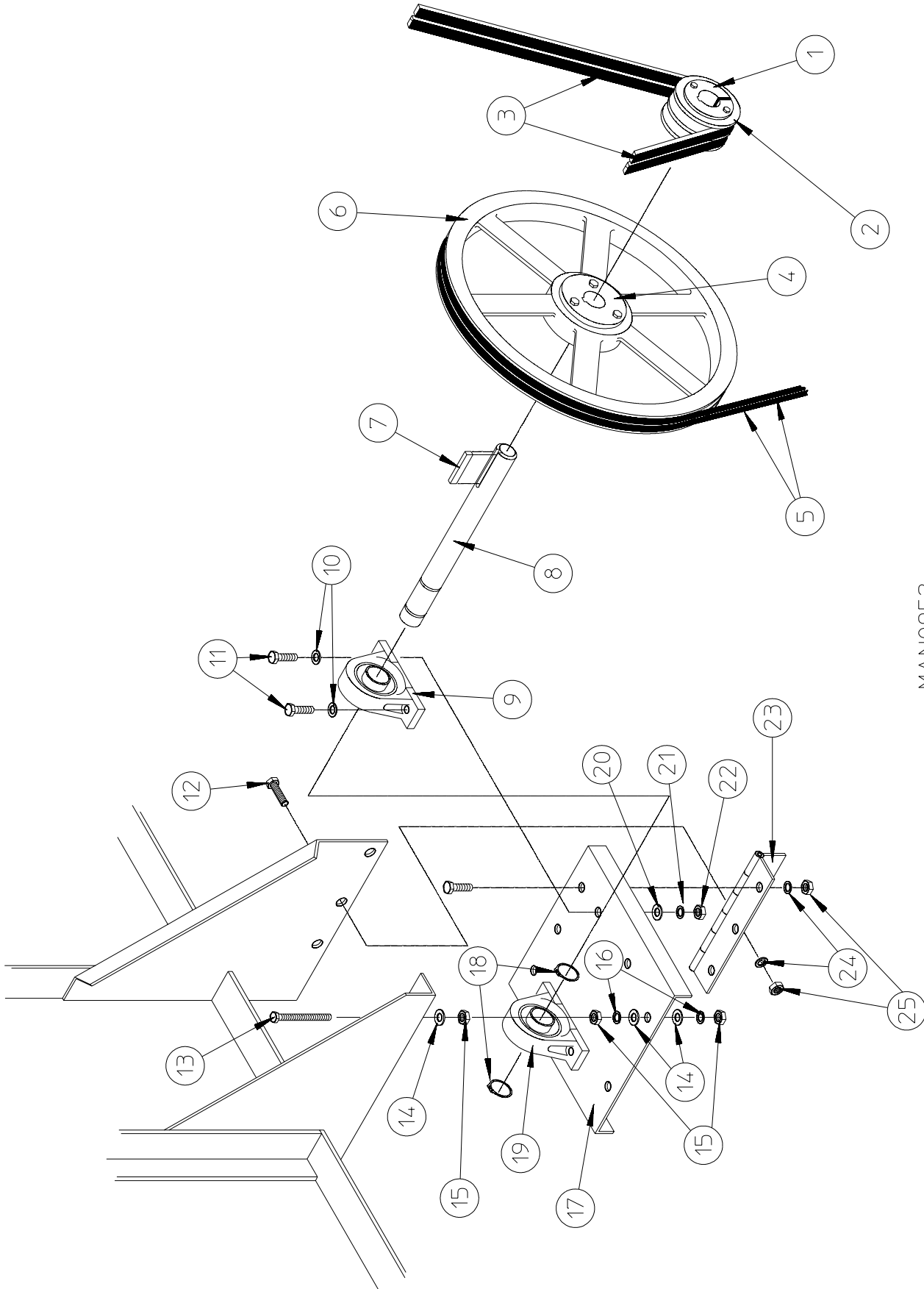

MAN0952

<u>Illus. No.</u>	<u>Part No.</u>	<u>Qty.</u>	<u>Description</u>
1	101152	1	SH x 1-3/8" Bushing
2	101113	1	2A3.0 Pulley
3*	100137	2	AB91 V-Belt
4	101184	1	SK x 1-3/8" Bore Bushing
5*	100102	2	3V740 V-Belt
6	101112	1	19" Idler Pulley
7	100730	1	1/4" x 1/4" x 4-5/8" Key
8	332152	1	Idler Shaft Only
9	100202	1	1-3/8" Pillow Block Bearing
10	153004	4	3/8" Flat Washer
11	150600	4	3/8-16 x 1-1/2" Hex Head Machine Bolt
12	150504	6	1/4-20 x 1/2" Hex Head Machine Bolt
13	150509	2	5/16-18 x 3" Hex Head Machine Bolt
14	153001	6	5/16" Flat Washer
15	152004	6	5/16-18 Hex Nut
16	153002	8	5/16" Lock Washer
17	820932	1	Idler Bearing Mount Assembly Complete (includes illus. nos. 8 through 11 and 17 through 25)
	332151	1	Idler Bearing Mount Only
18	100802	2	1-3/8" Retaining Ring
19	100202	1	3/8" Pillow Block Bearing
20	153004	4	3/8" Flat Washer
21	153005	4	3/8" Lock Washer
22	152005	4	3/8-16 Hex Nut
23	103005	1	Idler Adjustment Hinge
24	153002	6	1/4" Lock Washer
25	152004	6	1/4-20 Hex Nut

* Replace in matched sets (both belts).

Totally Enclosed, Fan-Cooled Basket Motor Mount Assembly

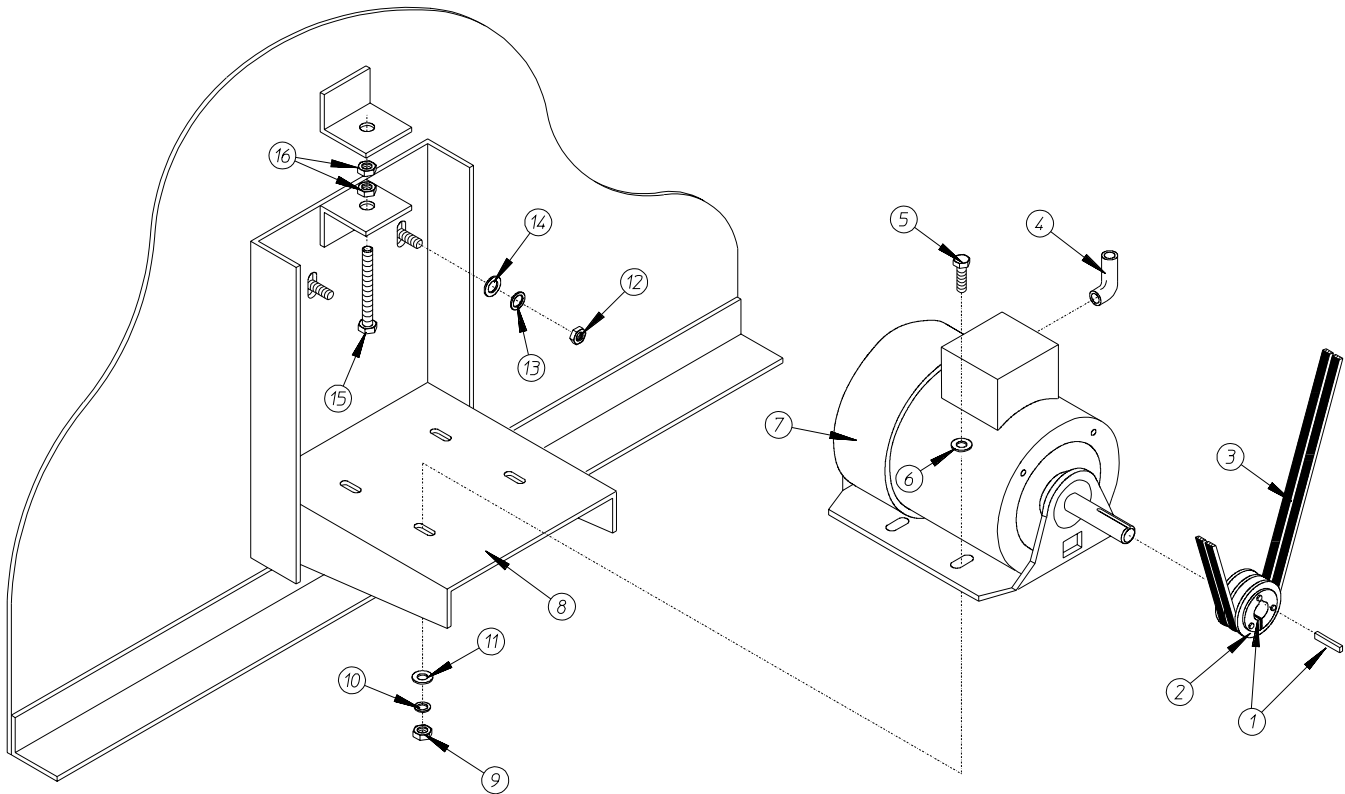

MAN0329

Illus. No.	Part No.	Qty.	Description
1	101121	1	5/8" SK Bushing
2	101114	1	2.65" Pulley (60 Hz only)
	101120	1	3.15" Pulley (50 Hz only)
3*	100102	2	3V740 V-Belt
4	120200	1	3/8" x 90° Connector
5	150501	4	5/16-18 x 3/4" Hex Head Machine Bolt
6	153001	4	5/16" Flat Washer
7	100050	1	1 hp 208 / 230 / 380 / 460v, 50 / 60 Hz 3ø Totally Enclosed, Fan-Cooled Motor (56Z frame)
8	800952	1	Basket Motor Mount Only (56Z frame)
	820941**	1	50 / 60 Hz Totally Enclosed, Fan-Cooled Basket Motor Mount Assembly Complete (includes illus. nos. 1 and 4 through 11) Note: Motor Pulley Must Be Ordered Separately
9	152004	4	5/16-18 Hex Nut
10	153002	4	5/16" Lock Washer
11	153001	4	5/16" Flat Washer
12	152004	4	5/16-18 Hex Nut
13	153002	4	5/16" Lock Washer
14	153001	4	5/16" Flat Washer
15	150619	1	3/8-16 x 3" Hex Head Machine Bolt
16	152005	2	3/8-16 Hex Nut

IMPORTANT: For voltages higher than 460v, contact the factory for correct part number of motor or motor mount assembly.

* Replace in matched sets (both belts).

** Specify voltage when ordering.

Blower Motor, Fan, and Shaft Assembly

For 60 Hz Steam and 50 Hz Gas Models Only

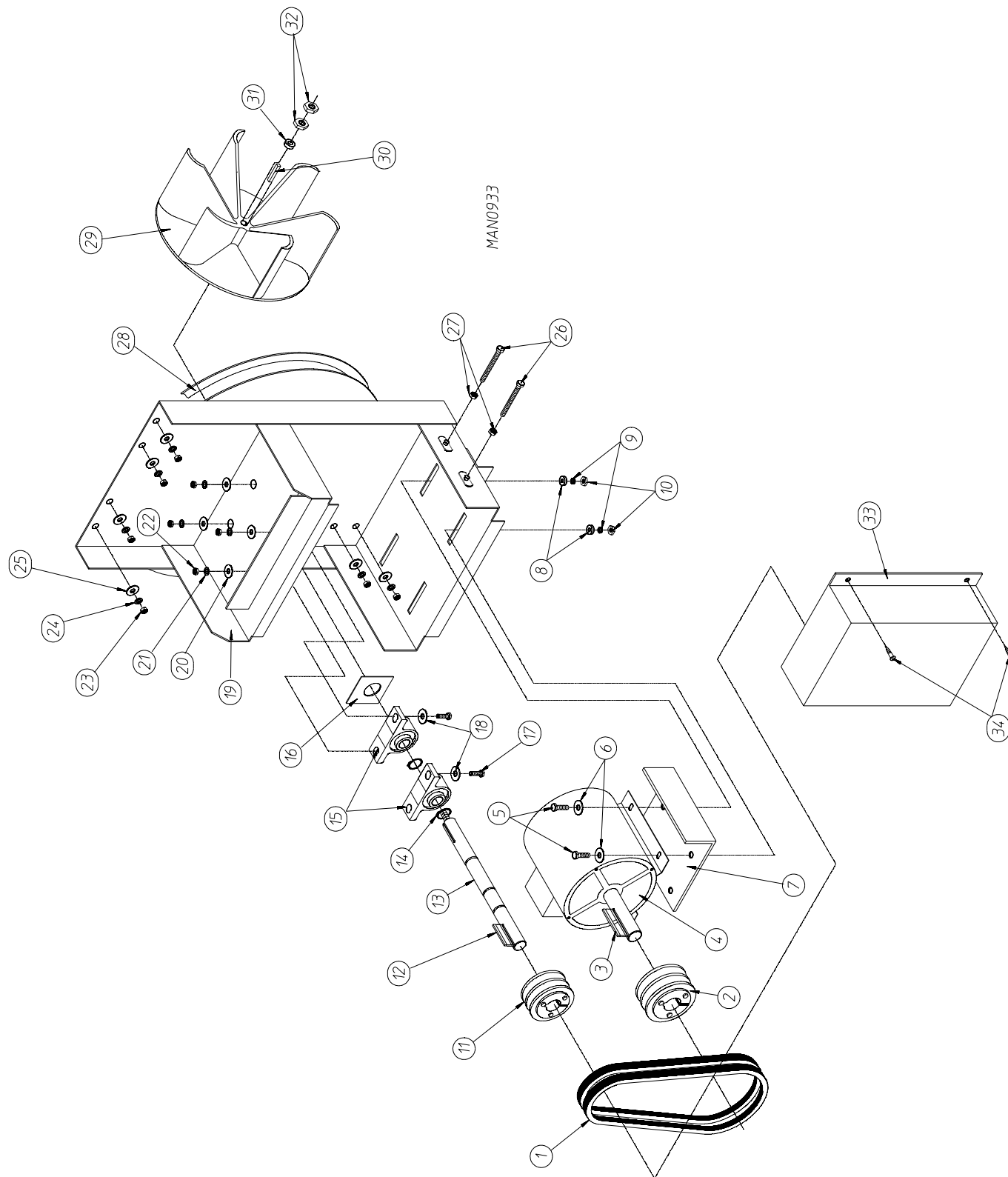

Blower Motor, Fan, and Shaft Assembly

For 60 Hz Steam and 50 Hz Gas Models Only

<u>Illus. No.</u>	<u>Part No.</u>	<u>Qty.</u>	<u>Description</u>
1*	100118	1	5L310 V-Belt
2	101134	1	2B x 4.6 Motor Sheave
	101138	1	SDS x 1-1/8" Bushing
3	100704	1	1/4" x 1/4" x 1-3/4" Key
4	100045	1	5 hp 230 / 460v, 50 / 60 Hz 3ø Motor
5	150617	4	3/8-16 x 1" Hex Head Machine Bolt
6	153004	4	3/8" Flat Washer
7	332198	1	Motor Adjustment Bracket
8	153004	4	3/8" Flat Washer
9	153005	4	3/8" Lock Washer
10	152005	4	3/8-16 Hex Nut
11	101143	1	2B x 3.8 Sheave
	101152	1	SH x 1-3/8" Bushing
12	100706	1	5/16" x 5/16" x 1-3/8" Key
13	332195	1	Fan Shaft
14	100802	2	1-3/8" Retaining Ring
15	100202	2	1-3/8" Pillow Block Bearing
16	116014	1	2" x 2" Fan Shaft Gasket
17	150606	4	1/2-13 x 2" Hex Head Machine Bolt
18	153016	4	1/2" Flat Washer
19	820960	1	Blower Motor Mount Only
	820981	1	Steam 60 Hz / Gas 50 Hz Blower Motor Mount Assembly Complete (includes illus. nos. 1 through 22 and 26 through 34)
20	153016	4	1/2" Flat Washer
21	153026	4	1/2" Lock Washer
22	152011	4	1/2-13 Hex Nut
23	152005	8	3/8-16 Hex Nut
24	153005	8	3/8" Lock Washer
25	153004	8	3/8" Flat Washer
26	150609	2	1/2-13 x 4-1/2" Hex Head Machine Bolt
27	152011	2	1/2-13 Hex Nut
28	117600	6	Noise Suppression Tape
29	100609	1	20" Aluminum Impellor
30	100708	1	3/16" x 3/16" x 2-1/16" Key
31	153065	1	Fan Washer
32	152006	2	1/2-20 Left-Hand Jam Nut
33	820965	1	Belt Guard
34	150522	4	1/4-20 x 1" Hex Washer TEK Screw

* Replace in matched sets (both belts).

Blower Motor, Fan, and Shaft Assembly

For 50 Hz Steam Only

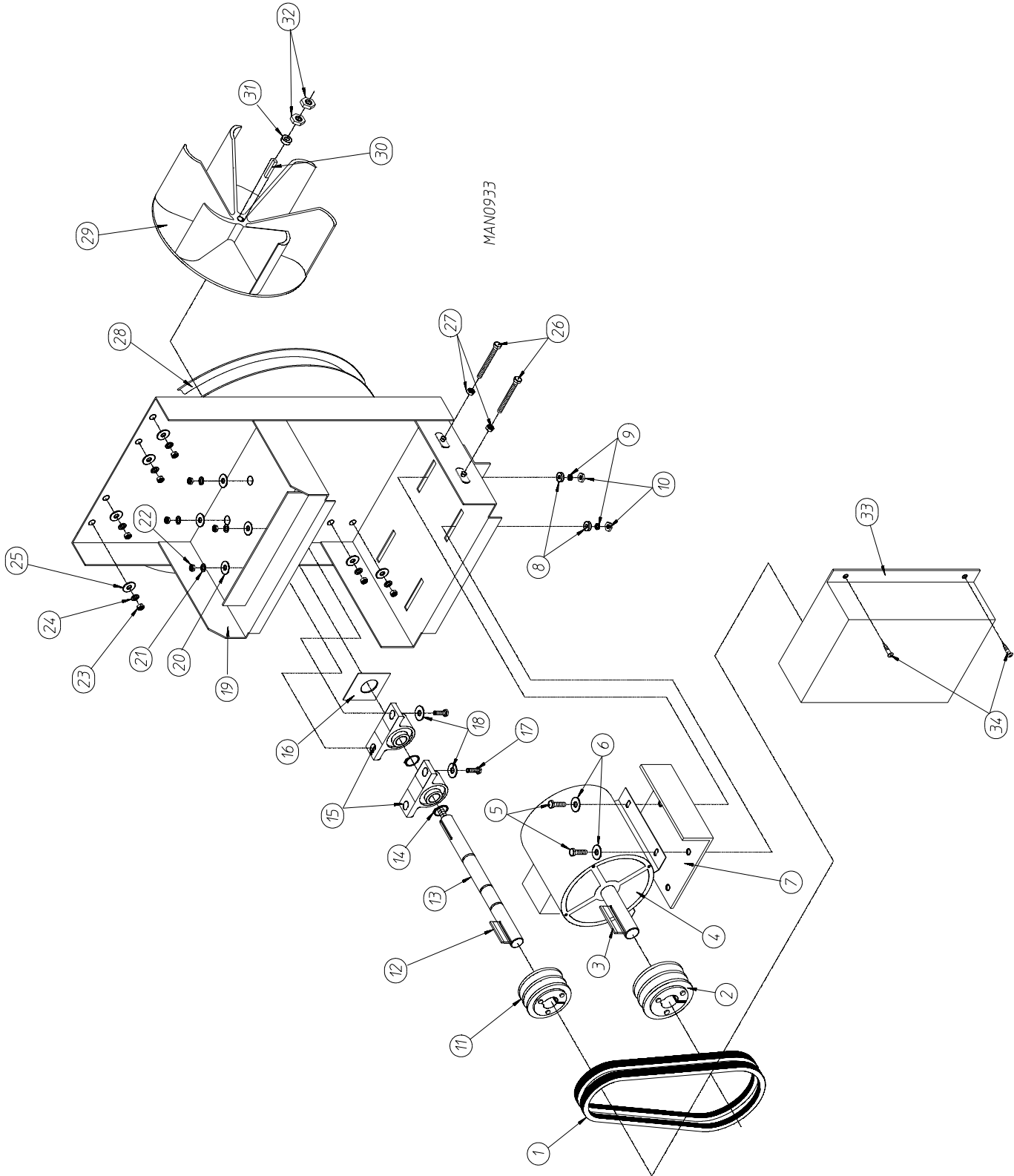

Blower Motor, Fan, and Shaft Assembly

For 50 Hz Steam Only

<u>Illus. No.</u>	<u>Part No.</u>	<u>Qty.</u>	<u>Description</u>
1*	100119	1	5L320 V-Belt
2	101135	1	2B x 5.4 Motor Sheave
	101138	1	SDS x 1-1/8" Bushing
3	100704	1	1/4" x 1/4" x 1-3/4" Key
4	100045	1	5 hp 230 / 460v, 50 / 60 Hz 3ø Motor
5	150617	4	3/8-16 x 1" Hex Head Machine Bolt
6	153004	4	3/8" Flat Washer
7	332198	1	Motor Adjustment Bracket
8	153004	4	3/8" Flat Washer
9	153005	4	3/8" Lock Washer
10	152005	4	3/8-16 Hex Nut
11	101143	1	2B x 3.8 Sheave
	101152	1	SH x 1-3/8" Bushing
12	100706	1	5/16" x 5/16" x 1-3/8" Key
13	332195	1	Fan Shaft
14	100802	2	1-3/8" Retaining Ring
15	100202	2	1-3/8" Pillow Block Bearing
16	116014	1	2" x 2" Fan Shaft Gasket
17	150606	4	1/2-13 x 2" Hex Head Machine Bolt
18	153016	4	1/2" Flat Washer
19	820960	1	Blower Motor Mount Only
	820982	1	50 Hz Blower Motor Mount Assembly Complete (includes illus. nos. 1 through 22 and 26 through 34)
20	153016	4	1/2" Flat Washer
21	153026	4	1/2" Lock Washer
22	152011	4	1/2-13 Hex Nut
23	152005	8	3/8-16 Hex Nut
24	153005	8	3/8" Lock Washer
25	153004	8	3/8" Flat Washer
26	150609	2	1/2-13 x 4-1/2" Hex Head Machine Bolt
27	152011	2	1/2-13 Hex Nut
28	117600	6	Noise Suppression Tape
29	100609	1	20" Aluminum Impellor
30	100708	1	3/16" x 3/16" x 2-1/16" Key
31	153065	1	Fan Washer
32	152006	2	1/2-20 Left-Hand Jam Nut
33	820965	1	Belt Guard
34	150522	4	1/4-20 x 1" Hex Washer TEK Screw

* Replace in matched sets (both belts).

Direct Spark Ignition Burner Assembly

For Gas Models Only

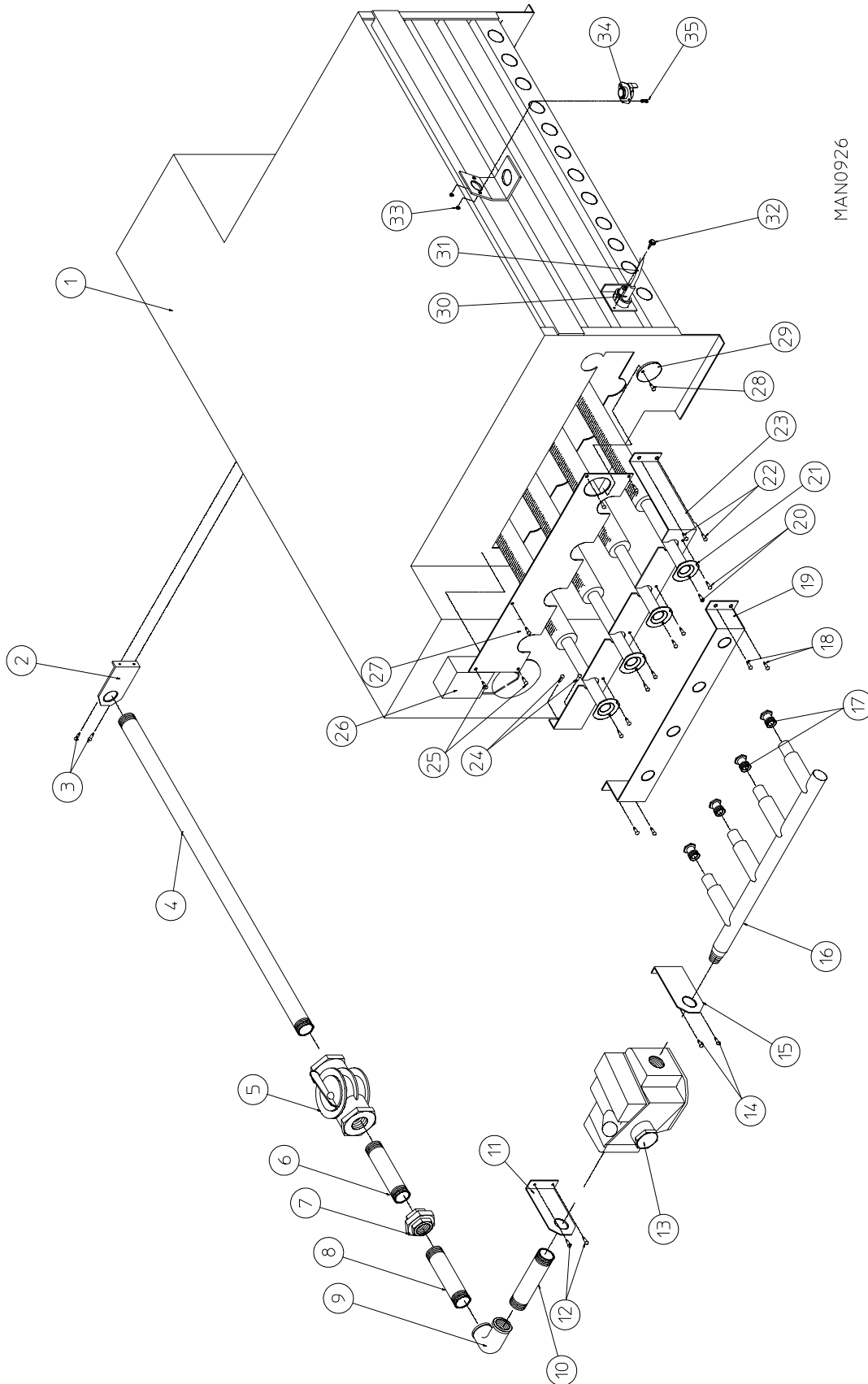

Direct Spark Ignition Burner Assembly

For Gas Models Only

<u>Illus. No.</u>	<u>Part No.</u>	<u>Qty.</u>	<u>Description</u>
1	820988*	1	Natural Gas Direct Spark Ignition Burner Assembly Complete Less Orifices (includes illus. nos. 1 through 16 and 18 through 35)
	820989*	1	Liquid Propane Gas Direct Spark Ignition Burner Assembly Complete Less Orifices (includes illus. nos. 1 through 16 and 18 through 35)
	820987	1	Burner Box Only
2	332117	1	Pipe Bracket
3	150415	2	#10-16 x 1/2" Phillips Right-Hand Crimptite Screw
4	142817	1	1" x 28-1/2" Pipe
5	141302	1	1" Union Shutoff
6	142711	1	1" Close Nipple
7	142602	1	1" Union
8	142711	1	1" Close Nipple
9	142548	1	1" x 90° Elbow
10	142581	1	1" x 5" Nipple
11	332119	1	Gas Valve Pipe Bracket
12	150415	2	#10-16 x 1/2" Phillips Right-Hand Crimptite Screw
13	140017	1	Direct Spark Ignition 1" 24VAC Redundant (natural gas) Gas Valve
	882945	1	Direct Spark Ignition 1" 24VAC Redundant (liquid propane gas) Gas Valve
	140018	1	1" 24VAC Gas Valve Liquid Propane Conversion Kit
14	150415	2	#10-16 x 1/2" Phillips Right-Hand Crimptite Screw
15	332119	1	Gas Valve Pipe Bracket
16	141240	1	4-Port Manifold
17**	140832	4	#4 Burner Orifice (natural gas)
	140819	4	#30 Burner Orifice (liquid propane gas)
18	150415	4	#10-16 x 1/2" Phillips Right-Hand Crimptite Screw
19	332114	1	Manifold Support Only
20	150415	8	#10-16 x 1/2" Phillips Right-Hand Crimptite Screw
21	141110	4	Burner Tube Only
22	150415	2	#10-16 x 1/2" Phillips Right-Hand Crimptite Screw
23	332121	1	Burner Tube Support Only
24	150415	2	#10-16 x 1/2" Phillips Right-Hand Crimptite Screw
25	150415	6	#10-16 x 1/2" Phillips Right-Hand Crimptite Screw
26	—	1	Sail Switch (refer to Sail Switch Assembly on page 25)
27	332113	1	Burner Box Cover Plate Only
28	150415	1	#10-16 x 1/2" Phillips Right-Hand Crimptite Screw
29	331290	1	Ignitor / Flame-Probe Sight Hole Disc Only
30	128914	1	Ignitor / Flame-Probe Assembly
	305410	1	Direct Spark Ignition Ignitor Gap Feeler Gauge ... Not Illustrated
31	884278	1	High Voltage Wire (for models with 1/4" spade connection at module)
	128919	1	High Voltage Wire (for models with spike style connection at module)
32	150415	2	#10-16 x 1/2" Phillips Right-Hand Crimptite Screw
33	151000	2	#6-32 Pal Nut
34	130401	1	330° Hi-Limit
35	150002	2	#6-32 x 1" Right-Hand Machine Screw
—	880743**	1	Direct Spark Ignition Liquid Propane Conversion Kit

* Orifices not included and must be ordered separately.

** Consult factory for elevations over 2,000 feet.

Direct Spark Ignition Module Mount Assembly

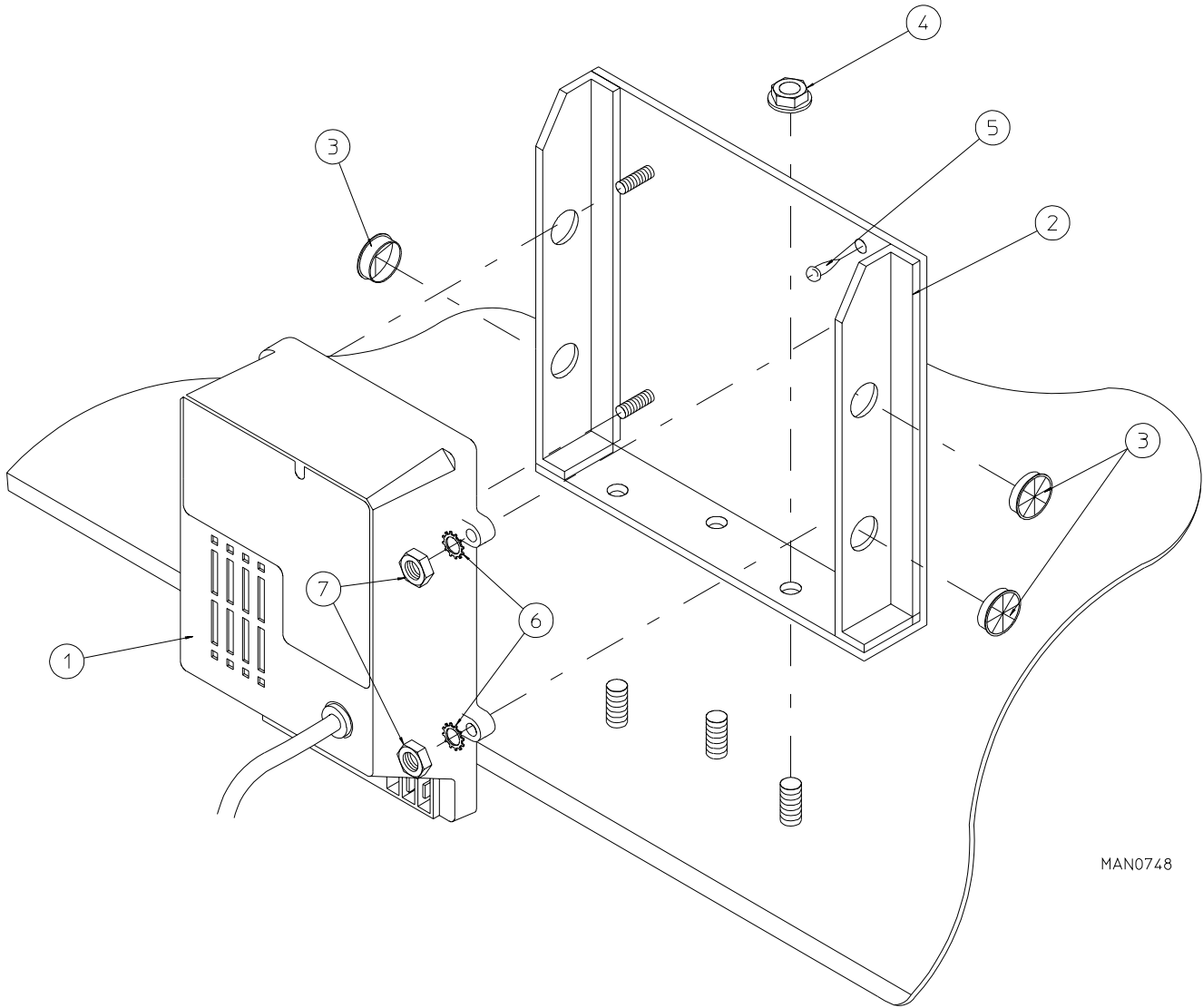

MAN0748

Illus. No.	Part No.	Qty.	Description
1	883849	1	Direct Spark Ignition Module with High Voltage Wire
2	820100	1	Direct Spark Ignition Module Mount Assembly Only
3	121400	3	Universal Bushing
4	152014	3	1/4-20 Free Spin Wash Nut
5	150301	1	#8-18 x 7/16" Phillips Pan Head TEK Screw
6	153010	4	#6 Star Washer
7	152000	4	#6-32 Hex Nut

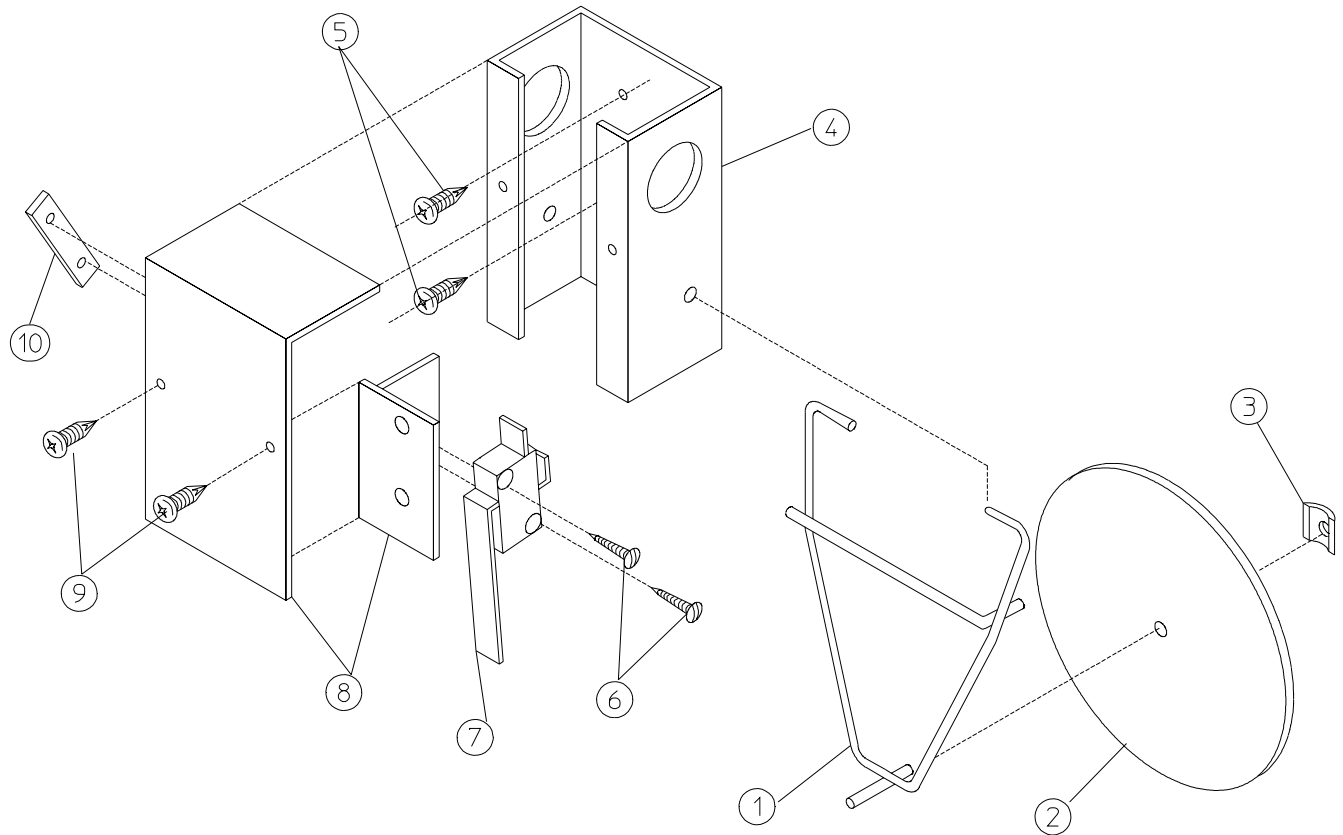

MAN0440

<u>Illus. No.</u>	<u>Part No.</u>	<u>Qty.</u>	<u>Description</u>
1	105500	1	Sail Switch Actuator Rod
2	319202	1	Sail Switch Damper (flat)
3	154002	1	1/8" Push-On Fastener
4	802800	1	Sail Switch Box with Cover and Bracket Only
	802801	1	Sail Switch Box Assembly Complete (includes illus. nos. 1 through 4 and 6 through 10)
5	150300	2	#10 x 1/2" Hex Washer TEK Screw
6	150303	2	#4 x 3/4" Pan Head "A" Machine Screw
7	122200	1	Sail Switch
8	802799	1	Sail Switch Box Cover and Bracket
9	150415	2	#10-16 x 1/2" Phillips Crimpite Screw
10	154004	1	Twin Speed Nut

Steam Damper Assembly

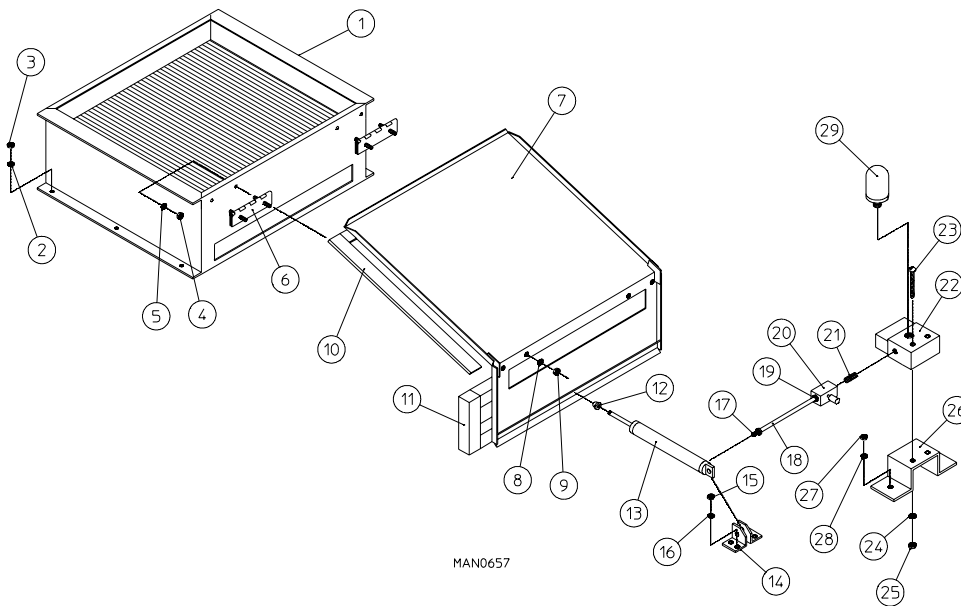

MAN0657

Illus. No.	Part No.	Qty.	Description
1	165017	1	Steam Coil Assembly
2	153002	6	5/16" Lock Washer
3	152004	6	5/16-18 Hex Nut
4	152002	4	1/4-20 Hex Nut
5	153007	4	1/4" Lock Washer
6	820321	2	Steam Damper Hinge Assembly
7	820994	1	Steam Damper Assembly (includes illus. nos. 7, 10, and 11)
8	153007	4	1/4" Lock Washer
9	152002	4	1/4-20 Hex Nut
10	115995	96"	Steam Damper Gasket (sold by the inch)
11	102350	2	Steam Damper Foam (68-1/2" length)
12	151007	1	7/16-20 Stainless Steel Acorn Nut
13	100499	1	1-1/2" Bore x 3" Stroke Piston (for models mfd. as of February 21, 1991)
	100497	1	1-1/4" Bore x 3" Stroke Piston (for models mfd. prior to February 21, 1991)
14	100500	1	Piston Support Bracket (for models mfd. as of February 21, 1991)
	100492	1	Piston Support Bracket (for models mfd. prior to February 21, 1991)
15	152002	4	1/4-20 Hex Nut
16	153007	4	1/4" Lock Washer
17	100472	1	1/4" x 1/8" Connector
18	143110	1	1/4" Tubing (sold by the foot)
19	100472	1	1/4" x 1/8" Connector
20	100496	1	1/8" Needle Valve
21	143238	1	1/8" Close Nipple
22	100498	1	3-Way Micro Valve (24VAC)
23	150002	2	#6-32 x 1" Slotted Machine Screw
24	153010	2	#6 Star Washer
25	152000	2	#6-32 Hex Nut
26	330987	1	Micro Valve Support Bracket
27	152002	2	1/4-20 Hex Nut
28	153007	2	1/4" Lock Washer
29	100520	1	1/8" N.P.T. Silencer (muffler)

Microprocessor Reversing Control Box Assembly

For Models Mfd. as of June 21, 1991

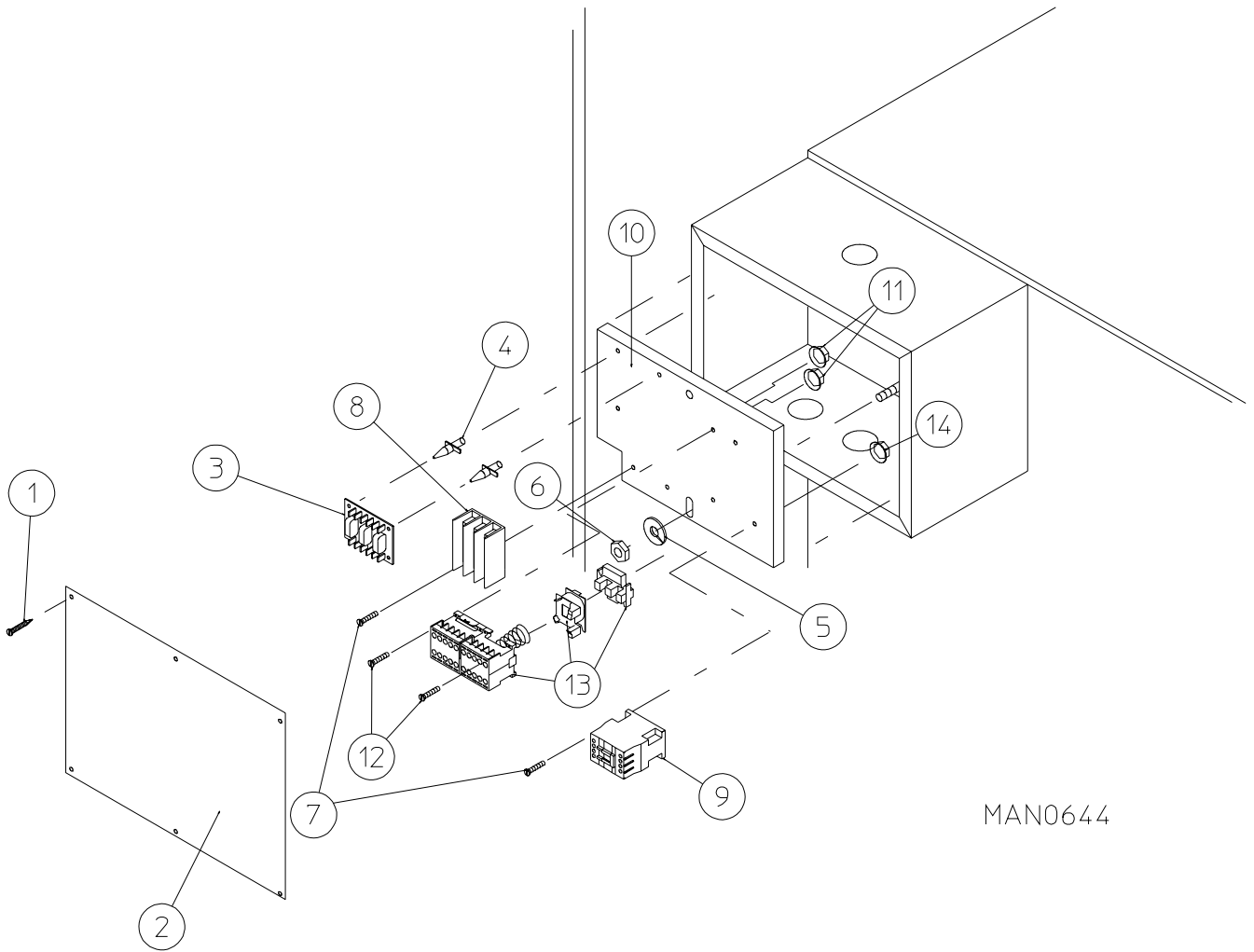

Illus. No.	Part No.	Qty.	Description
1	150301	6	#8-18 x 7/16" Phillips Pan Head TEK Screw
2	322808	1	Control Box Cover Plate
3	137060	1	Arc Suppressor Board
4	137013	4	Nylon Standoff
5	153002	1	5/16" Lock Washer
6	152004	1	5/16-18 Hex Nut
7	150108	4	#8-32 x 1/2" Pan Head Machine Screw
8	120704	1	3-Position Power Distribution Block
9	132445	1	Impellor (blower) Contactor
10	322807	1	Contactormounting Panel
11	151001	4	#8-32 Pal Nut
12	150108	4	#8-32 x 1/2" Pan Head Machine Screw
13	132431	1	Reversing Contactor (24 volt)
	132432	1	Contactormounting Replacement Coil (24 volt)
14	151001	4	#8-32 Pal Nut

Microprocessor Reversing Control Box Assembly

For Models Mfd. prior to June 21, 1991

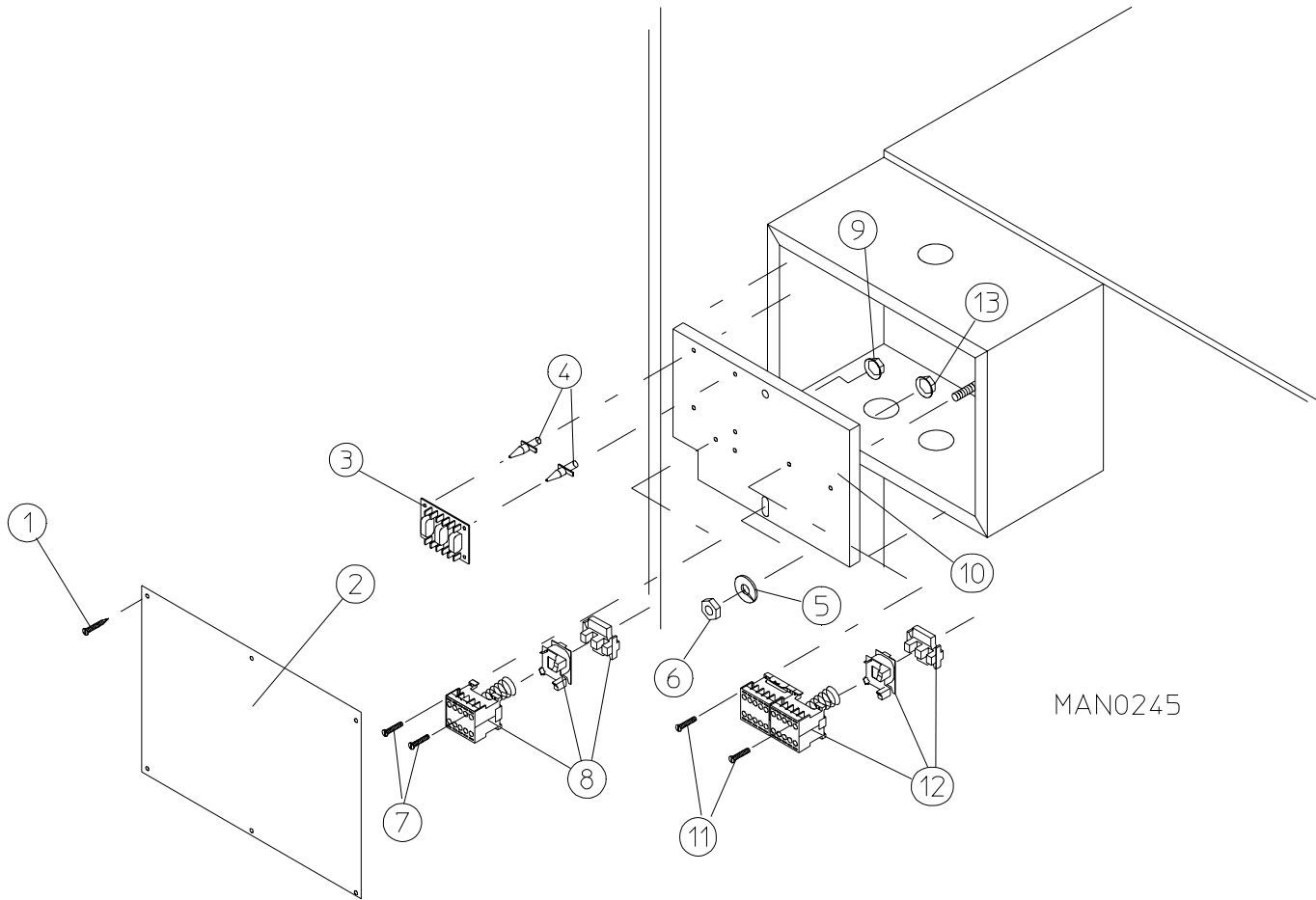

MAN0245

Illus. No.	Part No.	Qty.	Description
1	150301	6	#8-18 x 7/16" Phillips Pan Head TEK Screw
2	322808	1	Control Box Cover Plate
3	137060	1	Arc Suppressor Board
4	137013	4	Nylon Standoff
5	153002	1	5/16" Lock Washer
6	152004	1	5/16-18 Hex Nut
7	150108	4	#8-32 x 1/2" Pan Head Machine Screw
8	132430	1	Impellor Contactor (24 volt)
	132432	1	Impellor Contactor Replacement Coil (24 volt)
9	151001	4	#8-32 Pal Nut
10	322807	1	Contacteur Mounting Panel
11	150108	4	#8-32 x 1/2" Pan Head Machine Screw
12	132431	1	Reversing Contactor (24 volt)
	132432	1	Contacteur Replacement Coil (24 volt)
13	151001	4	#8-32 Pal Nut

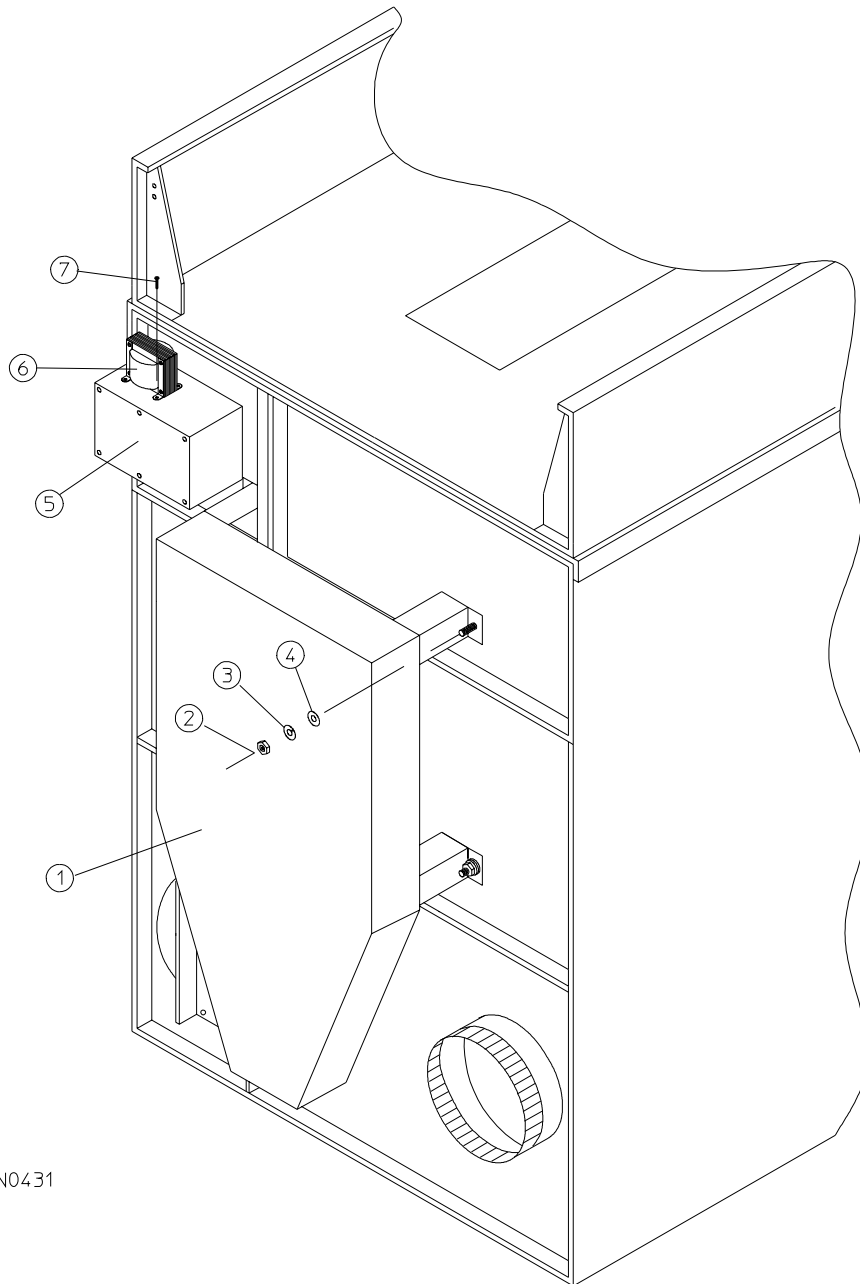

MAN0431

<u>Illus. No.</u>	<u>Part No.</u>	<u>Qty.</u>	<u>Description</u>
1	820908	1	Back Guard Assembly (gas models only)
	820978	1	Back Guard Assembly (steam models only)
2	152004	4	3/8-16 Hex Nut
3	153002	4	3/8" Lock Washer
4	153001	4	3/8" Flat Washer
5	322808	1	Control Box Cover Plate
6	132008	1	240-480 Volt / 120-240 Volt Stepdown Transformer (0.25 KVA)
	132011	1	380-600 Volt / 115-230 Volt Stepdown Transformer (0.25 KVA)
7	150300	4	#10 x 1/2" Hex Washer TEK Screw

Additional Parts Available

<u>Part No.</u>	<u>Description</u>
112027	"Water Washed Fabrics" Label
112040	"Lint Compartment" Label
112041	"Caution – Exhausted" Label
112090	"Phase 4 OPL Program Location Summary" Label
117505	Aluminum Duct Tape (sold by the foot)
120100	3/8" Straight (BX) Connector
120300	3/8" x 45° (BX) Connector
120400	3/8" Red Jacket (BX) Insulator
120500	3/8" Jiffy Clip (BX Retainer Clip)
120600	3/8" Greenfield (BX)
120800	1/4" In-Line Connector
120802	Red Butt Connector
120902	#74B Wire Nut
120903	Crimp-On Wire Nut
121014	1/4" Insulated (female) Terminal
121499	4" Harness Tie
121500	7" Harness Tie
121503	Harness Tie Mounting Clip
122804	Manometer (water column test gauge)

