



AD-170SE
Parts Manual
Phase 5 Microprocessor Models
Single / Dual Timer Models
1994 thru 2001

American Dryer Corporation
88 Currant Road
Fall River, MA 02720-4781
Telephone: (508) 678-9000 / Fax: (508) 678-9447
E-mail: techsupport@amdry.com

www.amdry.com

Retain This Manual In A Safe Place For Future Reference

American Dryer Corporation products embody advanced concepts in engineering, design, and safety. If this product is properly maintained, it will provide many years of safe, efficient, and trouble free operation.

ONLY qualified technicians should service this equipment.

OBSERVE ALL SAFETY PRECAUTIONS displayed on the equipment or specified in the installation manual included with the dryer.

The following “**FOR YOUR SAFETY**” caution must be posted near the dryer in a prominent location.

FOR YOUR SAFETY

Do not store or use gasoline or other flammable vapors and liquids in the vicinity of this or any other appliance.

POUR VOTRE SÉCURITÉ

Ne pas entreposer ni utiliser d'essence ni d'autres vapeurs ou liquides inflammables à proximité de cet appareil ou de tout autre appareil.

We have tried to make this manual as complete as possible and hope you will find it useful. ADC reserves the right to make changes from time to time, without notice or obligation, in prices, specifications, colors, and material, and to change or discontinue models.

Important

For your convenience, log the following information:

DATE OF PURCHASE _____ MODEL NO. **AD-170SE**
RESELLER'S NAME _____
Serial Number(s) _____

Replacement parts can be obtained from your reseller or the ADC factory. When ordering replacement parts from the factory, you can FAX your order to ADC at (508) 678-9447 or telephone your order directly to the ADC Parts Department at (508) 678-9000. Please specify the dryer model number and serial number in addition to the description and part number, so that your order is processed accurately and promptly.

The illustrations on the following pages may not depict your particular dryer exactly. The illustrations are a composite of the various dryer models. Be sure to check the descriptions of the parts thoroughly before ordering.

“IMPORTANT NOTE TO PURCHASER”

Information must be obtained from your local gas supplier on the instructions to be followed if the user smells gas. These instructions must be posted in a prominent location near the dryer.

Table of Contents

Control Door Assembly	4
Microprocessor Control Panel Assembly	5
Control Box Assembly for Microprocessor and Timer Models	6
Dual Timer “Tap Touch” Controls for Models Mfd. as of April 12, 2001	7
Dual Timer Control Panel Assembly for Models Mfd. Between January 3, 1995 and April 12, 2001	8
Single Timer Control Panel Assembly for Models Mfd. prior to January 3, 1995	9
Front Panel / Main Door Assemblies for Models Mfd. as of August 31, 2000	10
Front Panel / Main Door Assemblies for Models Mfd. prior to August 31, 2000	11
Main Door Switch Assembly for Models Mfd. as of September 9, 2000	12
Main Door Switch Assembly for Models Mfd. prior to September 9, 2000	13
Lint Door Assembly	14
Lint Drawer / Lint Drawer Switch Box Assemblies for Models Mfd. as of August 30, 1999	15
Lint Drawer / Lint Drawer Switch Box Assemblies for Models Mfd. Between December 1, 1994 and August 30, 1999	16
Lint Drawer / Lint Drawer Switch Box Assemblies for Models Mfd. prior to December 1, 1994	17
Microprocessor Temperature Sensor Bracket Assembly	18
Timer Temperature Sensor Bracket Assembly	19
Tumbler / Support Assemblies	20
Tumbler Bearing Mount Assembly	21
Idler Bearing Mount Assembly	22
T.E.F.C. Tumbler Motor Mount Assembly	23
Blower Motor Mount Assembly	24
Fan Shaft Mount Assembly for Gas Models Only	25
Fan Shaft Mount Assembly for Steam Models Only	26
Direct Spark Ignition Burner Assembly for Models Using Natural Gas Only	27
Direct Spark Ignition Burner Assembly for Models Using Liquid Propane Gas Only	28
Direct Spark Ignition Module Mount Assembly for Gas Models Only	30
Sail Switch Assembly	31
Steam Damper Assembly	32
Microprocessor Reversing Contactor Mounting Panel Assembly	33
Dual Timer Reversing Relay Mounting Panel Assembly	34
Top Console Assembly	35
Pneumatic Valve Assembly for Gas Models Only	36
Pneumatic Valve Assembly for Steam Models Only	37
Air Jet Assembly	38
Back Guard Assemblies for Models Mfd. as of June 16, 1995	39
Back Guard Assemblies for Models Mfd. prior to June 16, 1995	40
Direct Spark Ignition Burner Assembly Specifications	41
Step Down Transformer Application Listing	42
Additional Parts Available	43

Control Door Assembly

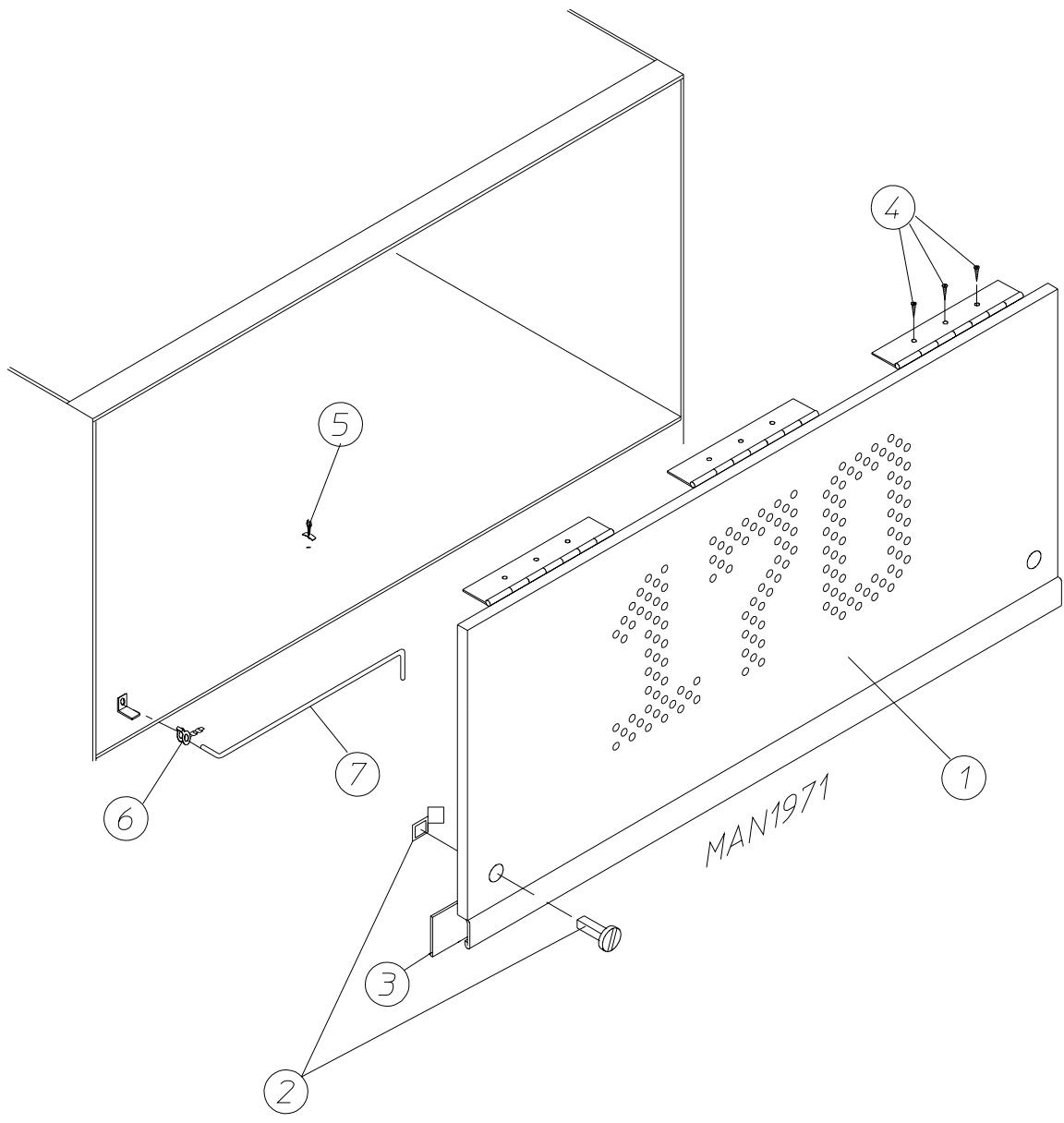

Illus. No.	Part No.	Qty.	Description
1*	820944	1	Control Door Assembly (for gas models Only)
	820963	1	Short Control Door (for steam models Only)
2	160005	2	Spring Turn Latch (2-piece)
3	117600	5	Gasket (sold by the foot)
4	150309	9	#10-16 x 1/2" Hex Head TEK Crimptite Screw
5	102600	1	Control Door Support Rod Catch
6	102601	1	Control Door Rod Retainer Clip
7	102505	1	Control Door Support Rod

* Specify color when ordering.

Microprocessor Control Panel Assembly

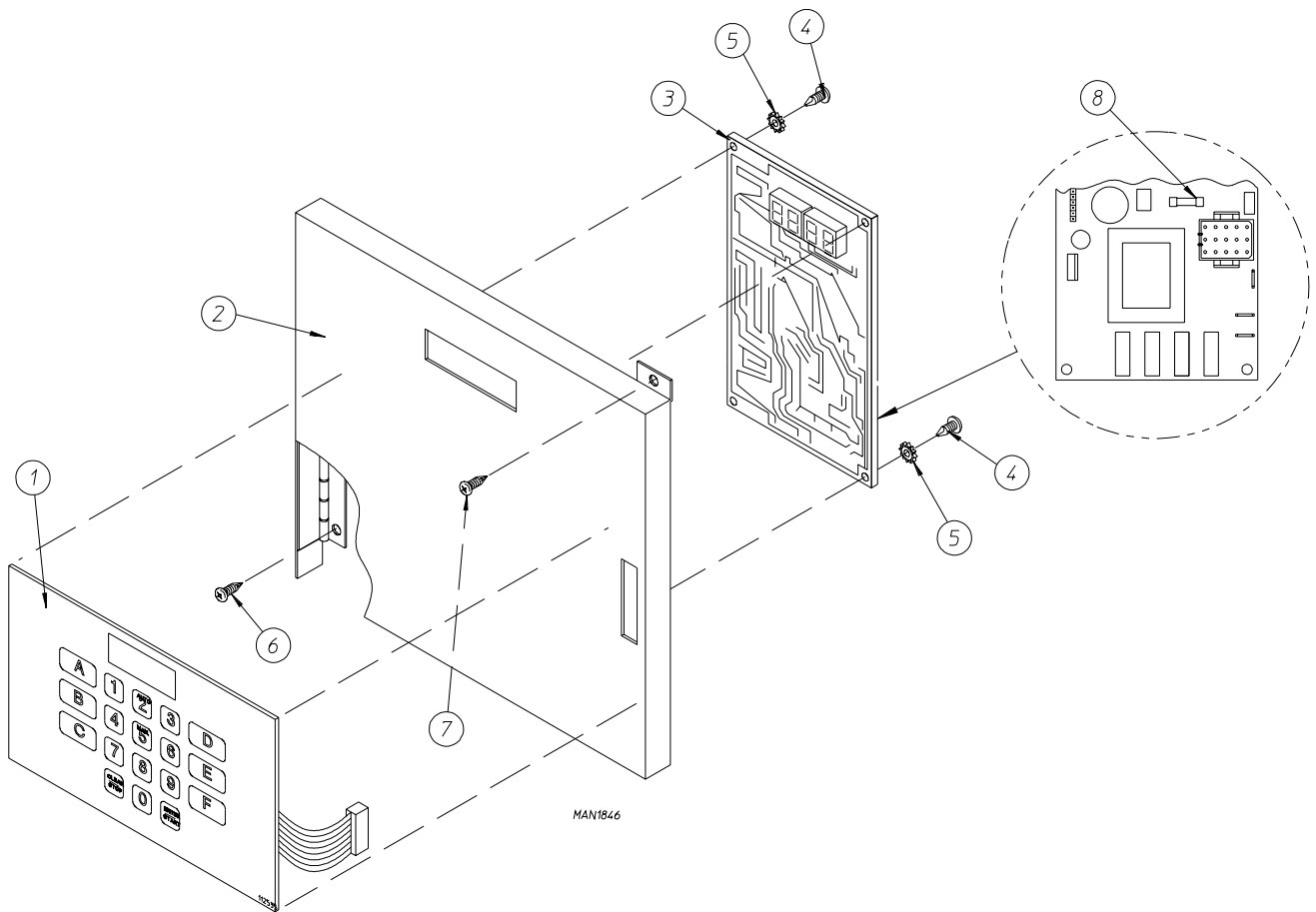

Illus. No.	Part No.	Qty.	Description
1	112535	1	Non-Coin English Keypad Label Assembly
	112276	1	Non-Coin Stick-On Labels (English Only) ... Not Illustrated
	112275	1	3-Language Non-Coin Stick-On Labels (Spanish, Italian, and Hebrew) ... Not Illustrated
	112277	1	3-Language Non-Coin Stick-On Labels (English, Spanish, and Hebrew) ... Not Illustrated
	112278	1	5-Language Non-Coin Stick-On Labels (Italian, Dutch, French, German, and Chinese) ... Not Illustrated
2*	821024	1	Computer Door Complete (includes illus. nos. 1 through 8)
	821101	1	Computer Door ONLY
	881055	1	Computer Door Complete with Battery Option (includes illus. nos. 1 through 8)
	821102	1	Computer Door with Battery Bracket ONLY
3	137225	1	Phase 5 Non-Coin Reversing Microprocessor Controller with Air Jet
4	150005	2	#6-32 x 1/4" Phillips Round Head Screw
5	153010	2	#6 Star Washer
6	150000	3	#6-32 x 1/4" Slotted Round Head Machine Screw
7	150309	1	#10-16 x 1/2" Hex Head TEK Crimptite Screw
8	136048	1	1/8-Amp (Slo-Blo) Fuse ONLY

* Specify color when ordering.

IMPORTANT: Check label on computer chip to verify correct part number.

Control Box Assembly

For Microprocessor and Timer Models

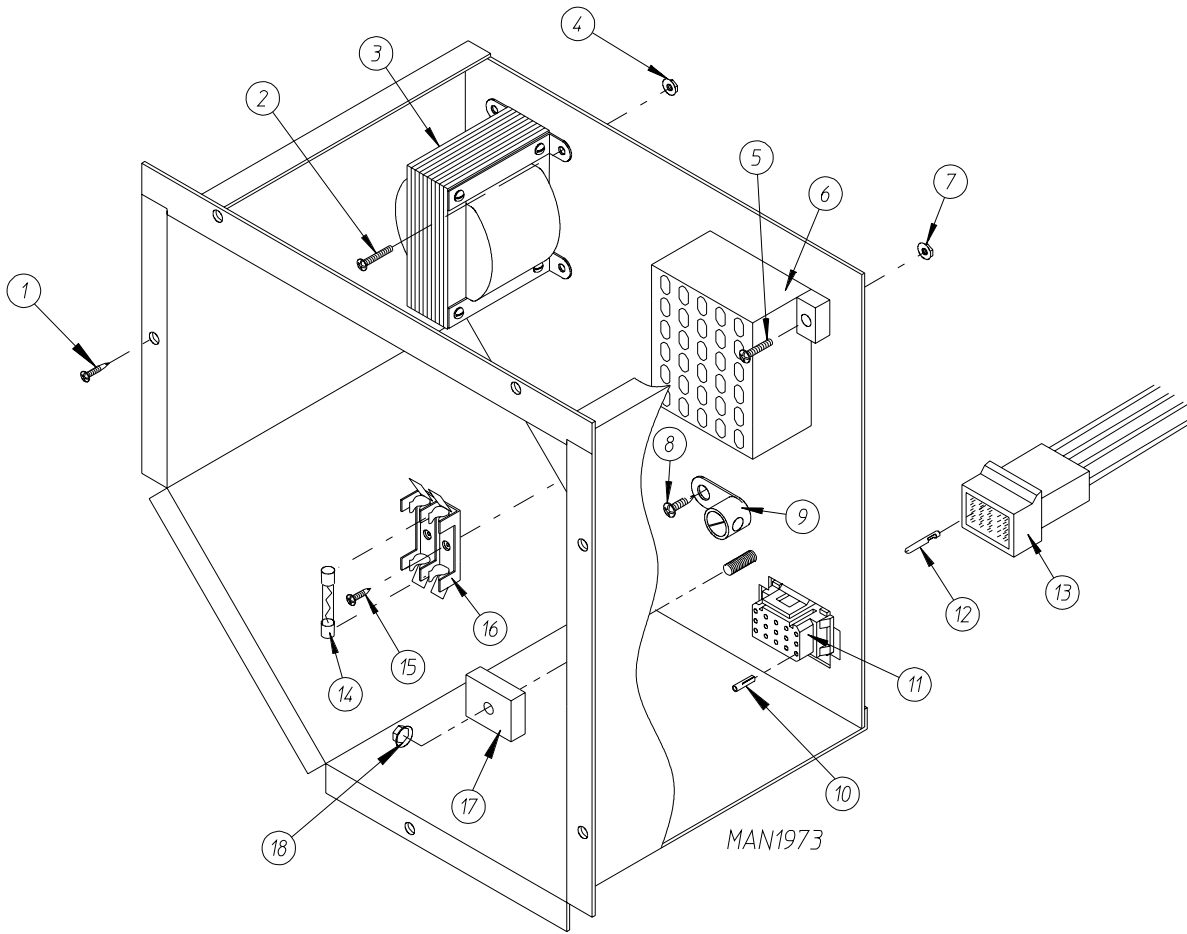

Illus. No.	Part No.	Qty.	Description
1	150301	6	#8-18 x 7/16" Phillips Pan Head TEK Screw
2	150100	2	#8-32 x 1/2" Phillips Round Head Machine Screw
3	132070	1	Transformer – 24 VAC (for microprocessor models Only)
4	151001	2	#8-32 Pal Nut
5	150002	2	#6-32 x 1" Phillips Round Head Machine Screw
6	120715	1	30-Position Terminal Block
7	151000	2	#6-32 Pal Nut
8	150309	1	#10-16 x 1/2" Hex Head TEK Crimptite Screw
9	121010	1	L-70 Ground Lug
10	122705	*	Socket Terminal ONLY
	122801	1	Pin / Socket Extraction Tool
11	122626	1	15-Pin Connector ONLY
12	122704	*	Pin Terminal ONLY
13	122625	1	15-Pin Connector ONLY
	122800	1	Microprocessor (female) Pin Extraction Tool
14	136057	2	1/2-Amp (Slo-Blo) Fuse ONLY
15	150301	2	#8-18 x 7/16" Phillips Pan Head TEK Screw
16	136008	2	Fuse Block / Strip ONLY
17	124812	1	30-Second Air Jet Timer (for timer models Only)
18	151000	1	#6-32 Pal Nut

* As required.

Dual Timer "Tap Touch" Controls

For Models Mfd. as of April 12, 2001

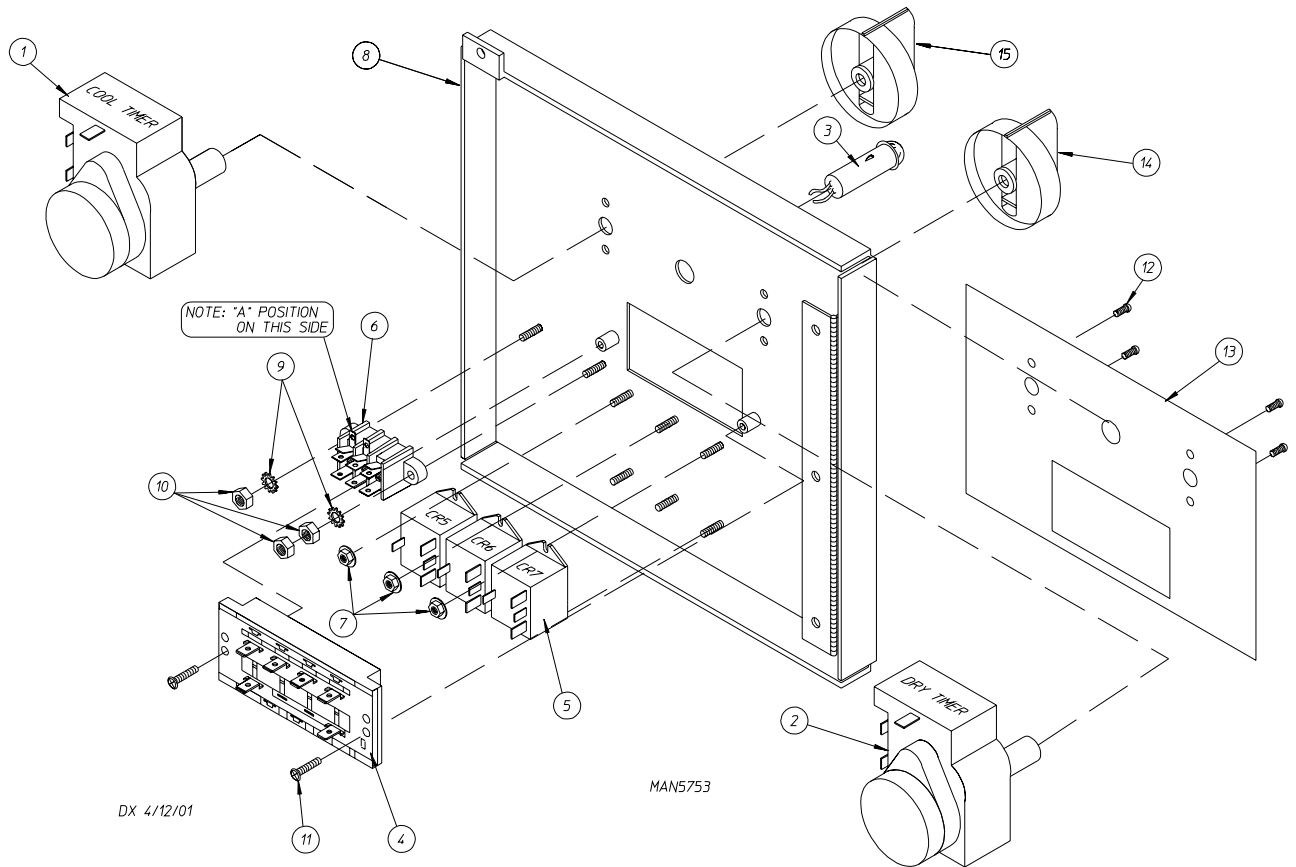

Illus. No.	Part No.	Qty.	Description
1	824298	1	15 Minute Timer – 24 VAC
2	824299	1	60 Minute Timer – 24 VAC
3	824175	1	Red Pilot Light – 24 VAC
4	122301	1	"Tap Touch" Switch
5	131932	3	24 VAC Relay
6	120708	1	3, Terminal Closed Block
7	151000	6	#6-32 Pal Nut
8	824297	1	Dual Timer Panel Complete (includes illus. nos. 1 through 15)
	824068	–	Dual Timer Panel ONLY
9	153010	2	#6 Star Washer
10	152000	3	#6-32 Hex Nut
11	150207	2	#10-24 x 1/2" Phillips Pan Head Machine Screw
12	150110	4	#8-32 x 1/4" Phillips Round Head Machine Screw
13	112563	1	Dual Timer Panel Overlay
14	124104	1	Pure Touch Knob with Red Pointer
15	124105	1	Pure Touch Knob with Blue Pointer

Dual Timer Control Panel Assembly

For Models Mfd. Between January 3, 1995 and April 12, 2001

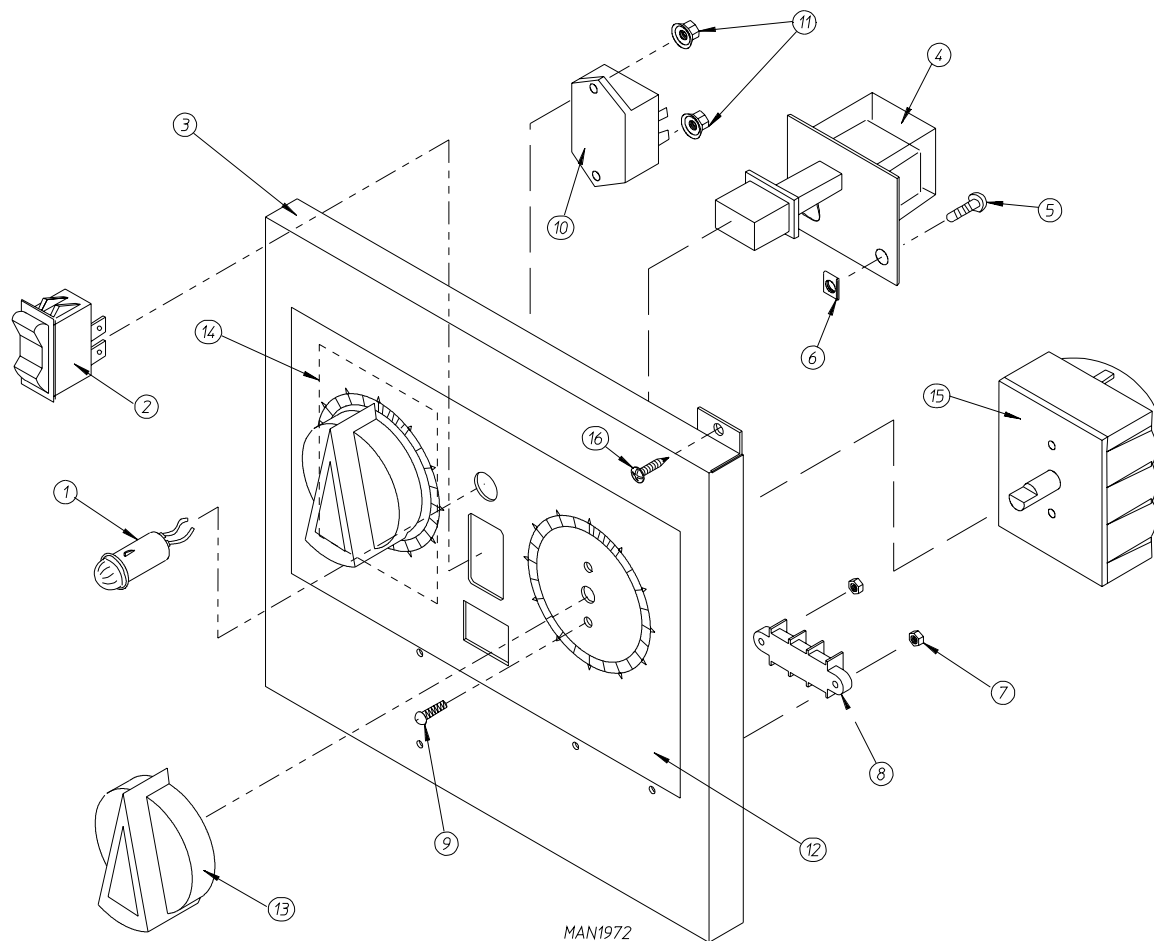

<u>Illus. No.</u>	<u>Part No.</u>	<u>Qty.</u>	<u>Description</u>
1	123005	1	Red Light Indicator – 24 VAC
2	122400	1	Rocker Heat Selector Switch
3*	881056	1	Dual Timer Control Panel Assembly Complete (includes illus. nos. 1 through 15)
	821118	1	Dual Timer Control Panel
4	131917	1	Push-To-Start Relay – 24 VAC
5	150207	2	#10-24 x 1/2" Round Head Machine Screw
6	154001	2	#10-24 Speed Nut
7	152000	2	#6-32 Hex Nut
8	120708	1	Terminal Strip
9	150110	2	#8-32 x 1/4" Phillips Round Head Screw
10	131931	1	Dual Timer Relay – 24 VAC
11	151000	2	#6-32 Pal Nut
12	112050	1	Dual Timer Label ONLY
13	124103	2	Arrow Timer Knob
14	124025	1	60 Minute Timer – 24 VAC
15	124030	1	15 Minute Timer – 24 VAC
16	150301	1	#8-18 x 7/16" Phillips Pan Head TEK Screw

* Specify color when ordering.

Single Timer Control Panel Assembly

For Models Mfd. prior to January 3, 1995

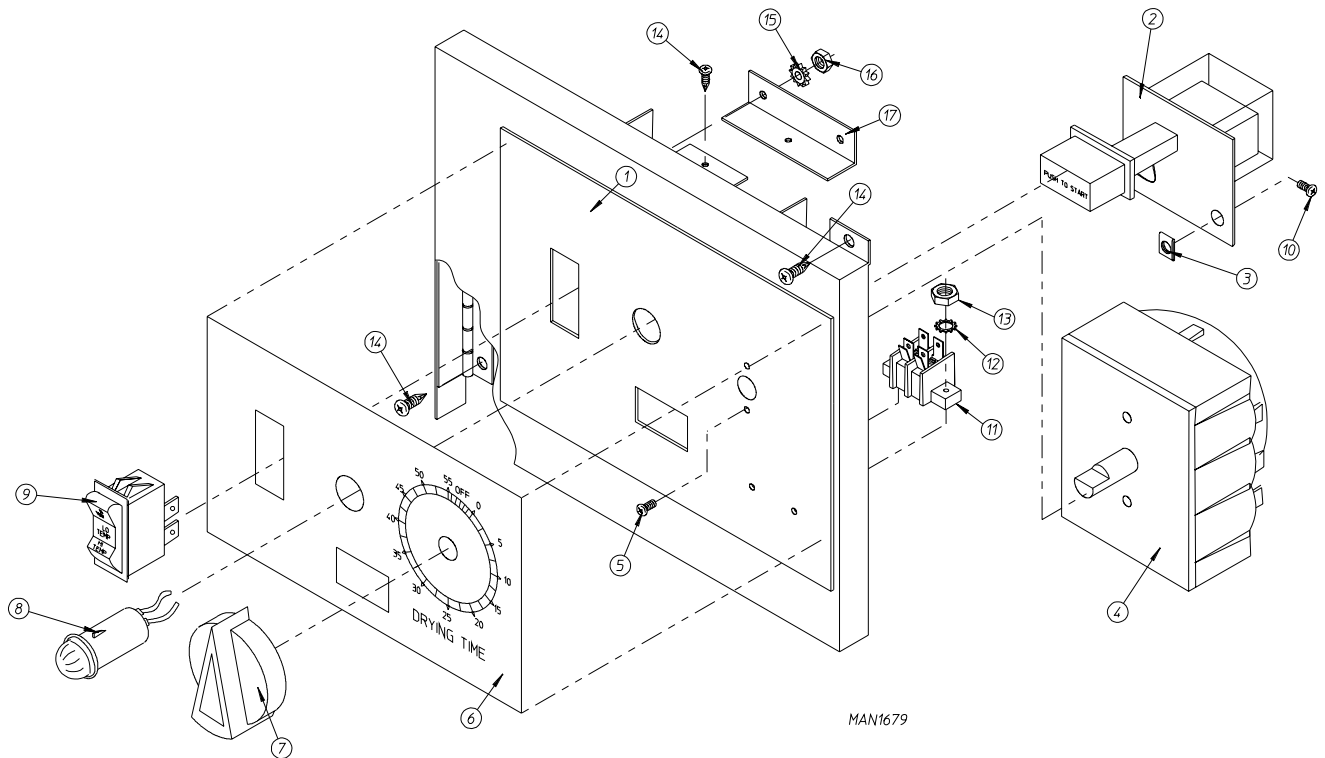

Illus. No.	Part No.	Qty.	Description
1*	881054	1	Single Timer Control Panel Assembly Complete (includes illus. nos. 1 through 17)
	821015	1	Single Timer Control Panel ONLY
2	131917	1	Push-To-Start Relay – 24 VAC
3	154001	2	#10-24 Speed Nut
4	124025	1	60 Minute Timer – 24 VAC
5	150110	2	#8-32 x 1/4" Phillips Round Head Machine Screw
6	112048	1	Single Timer Label ONLY
7	124103	1	Arrow Timer Knob
8	123005	1	Red Light Indicator – 24 VAC
9	122400	1	Rocker Heat Selector Switch
10	150207	2	#10-24 x 1/2" Phillips Pan Head Machine Screw
11	120707	1	Terminal Strip
12	153010	2	#6 Star Washer
13	152000	2	#6-32 Hex Nut
14	150301	5	#8-18 x 7/16" Phillips Pan Head TEK Screw
15	153012	2	#8 Star Washer
16	152001	2	#8-32 Hex Nut
17	332257	1	Single Timer Drawer Stop

* Specify color when ordering.

Front Panel / Main Door Assemblies

For Models Mfd. as of August 31, 2000

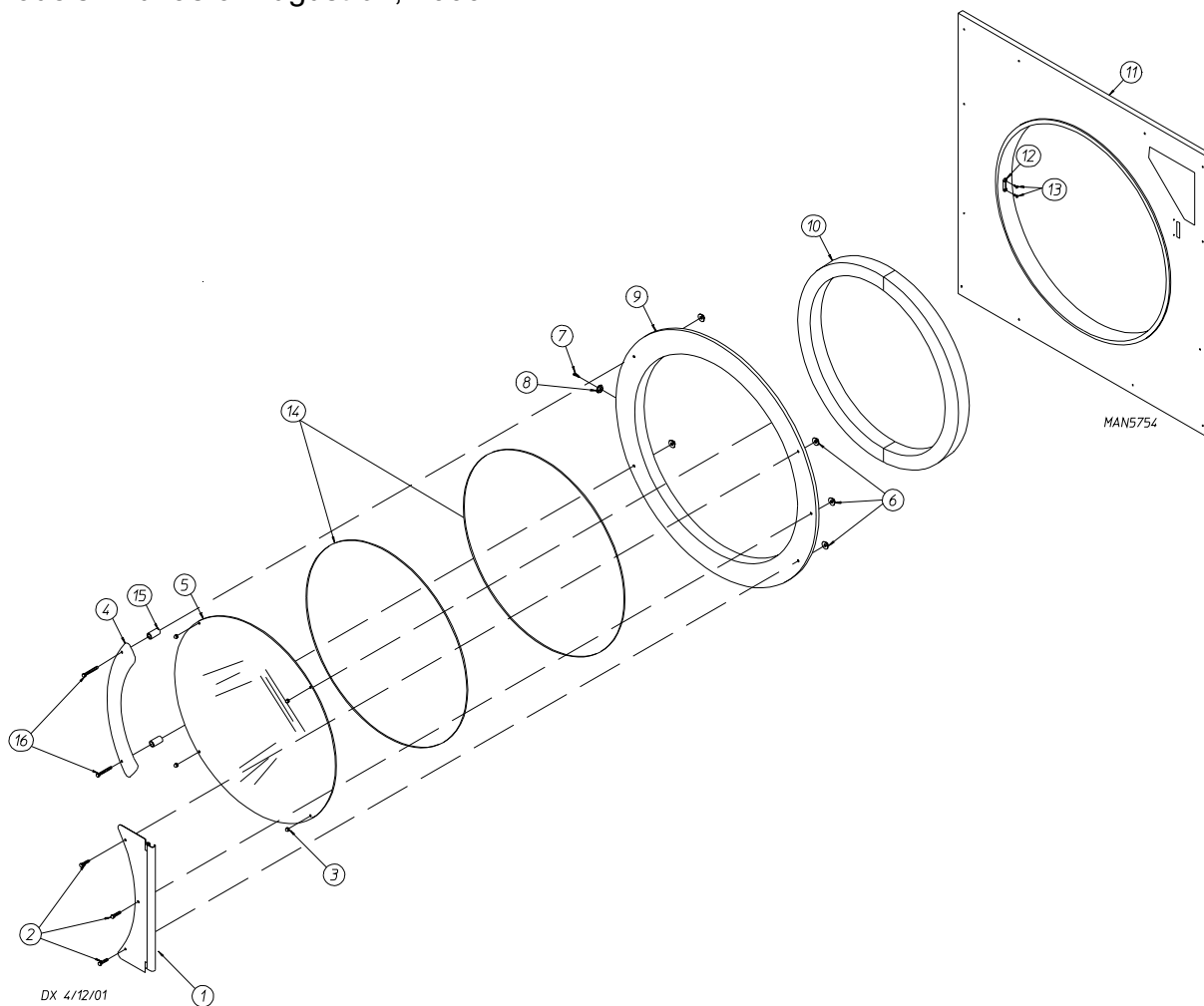

DX 4/12/01

Illus. No.	Part No.	Qty.	Description
1	883081	1	Door Hinge (black)
2	150683	4	1/4-20 x 5/8" Carriage Bolt
3	151012	1	#10-32 Acorn Nut (white)
4	883082	1	Black Main Door Handle
5	102214	1	30" Door Glass
	170730	1	Door Glass Adhesive (10.3 oz. cartridge)
6	152014	6	1/4-20 Free Spin Wash Nut
7	150120	1	Main Door Latch Screw (#10-32 dome hex head screw)
8	151010	1	#10-32 Acorn Nut
9	883083	1	Black Main Door Assembly Complete (includes illus. nos. 2 through 10)
	883080	1	Black Main Door Ring
10	882411	1	Extruded Steel Door Gasket
11	883084	1	White Front Panel Assembly (includes illus. nos. 1, 15, and 16)
	883085	1	Coral Wrinkle Blue Front Panel Assembly (includes illus. nos. 1, 15, and 16)
12	170330	1	Friction Door Latch
13	154215	2	5/32" Pop Rivet
14	102360	2	0.0625 x 0.125 Black Gasket
15	154270	2	1" Spacer
16	150685	2	1/4-20 x 1.75 Carriage Bolt

Front Panel / Main Door Assemblies

For Models Mfd. prior to August 31, 2000

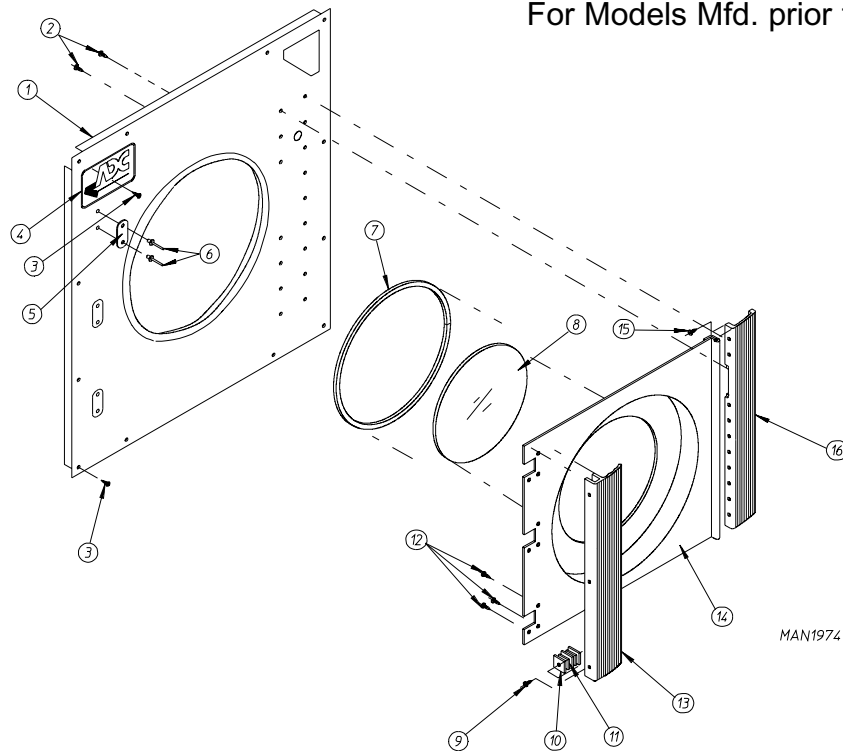

MAN1974

<u>Illus. No.</u>	<u>Part No.</u>	<u>Qty.</u>	<u>Description</u>
1*	820929	1	Right-Hand Front Panel Assembly (includes illus. nos. 1, 5, and 6)
2	150309	15	#10-16 x 1/2" Hex Head TEK Crimptite Screw
3	150412	12	#10-16 x 3/4" Phillips Round Head Crimptite Screw
4**	112360	1	ADC Logo ONLY
	870011	1	Logo Double Tape Kit
5	170340	3	3-1/2" Stainless Steel Striker Pad
6	154200	6	5/32" Pop Rivet
7	102308	1	Door Gasket ONLY (94" length)
8	102210	1	20-7/16" Door Glass ONLY
	170730	1	Door Glass Adhesive (10.3 oz. cartridge)
9	150401	3	#10-24 x 1-1/4" Phillips Taptite Screw
10	306801	6	Magnet Keeper ONLY
11	102102	6	1.0 x .750 x .215 Main Door Magnet ONLY
12	150309	9	#10-16 x 1/2" Hex Head TEK Crimptite Screw
13	180151	1	35" Gray Main Door Handle (for models mfd. as of March 8, 1993)
	180150	1	35" Gray Main Door Handle (for models mfd. prior to March 8, 1993)
14	800265*	1	Main Door Assembly Complete with Gray Handle (includes illus. nos. 7 through 14)
	800128	1	Stainless Steel Main Door Assembly Complete with Gray Handle (includes illus. nos. 7 through 14)
	800122*	1	Main Door Assembly with Glass and Gasket ONLY (includes illus. nos. 7, 8, and 14)
	800125	1	Stainless Steel Main Door Assembly with Glass and Gasket ONLY (includes illus. nos. 7, 8, and 14)
15	150430	11	#10 x 1/2" Phillips Pan Head Self-Drilling Machine Screw
16	180155	1	35" Gray Main Door Hinge Block ONLY

* Specify color when ordering.

** Logo tape kit is not included and must be ordered separately.

Main Door Switch Assembly

For Models Mfd. as of September 9, 2000

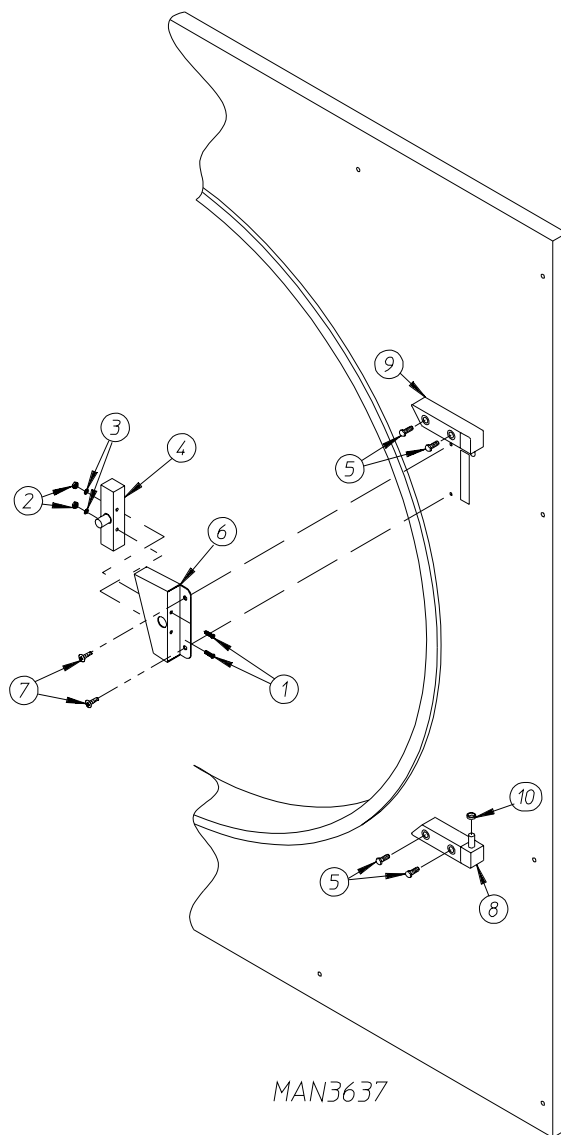

<u>Illus. No.</u>	<u>Part No.</u>	<u>Qty.</u>	<u>Description</u>
1	150006	2	#6-32 x 7/8" Phillips Pan Head Machine Screw
2	152013	2	#6-32 Hex Nut
3	153010	2	#6 Star Washer
4	137005	1	Single-Pole Door Switch
5	150443	4	1/4-20 x 3/4" Stainless Steel Cap Screw
6	881687	1	White Main Door Switch Housing ONLY
	881695	1	Blue Main Door Switch Housing ONLY
	881702	1	White Main Door Switch with Housing Assembly (includes illus. nos. 1 through 4 and 6)
	881700	1	Blue Main Door Switch with Housing Assembly (includes illus. nos. 1 through 4 and 6)
7	150443	2	1/4-20 x 3/4" Stainless Steel Cap Screw
8	881441	1	White Bottom Hinge Block
	881735	1	Blue Bottom Hinge Block
9	881440	1	White Top Hinge Block
	881736	1	Blue Top Hinge Block
10	153031	1	Nylon Washer

Main Door Switch Assembly

For Models Mfd. prior to September 9, 2000

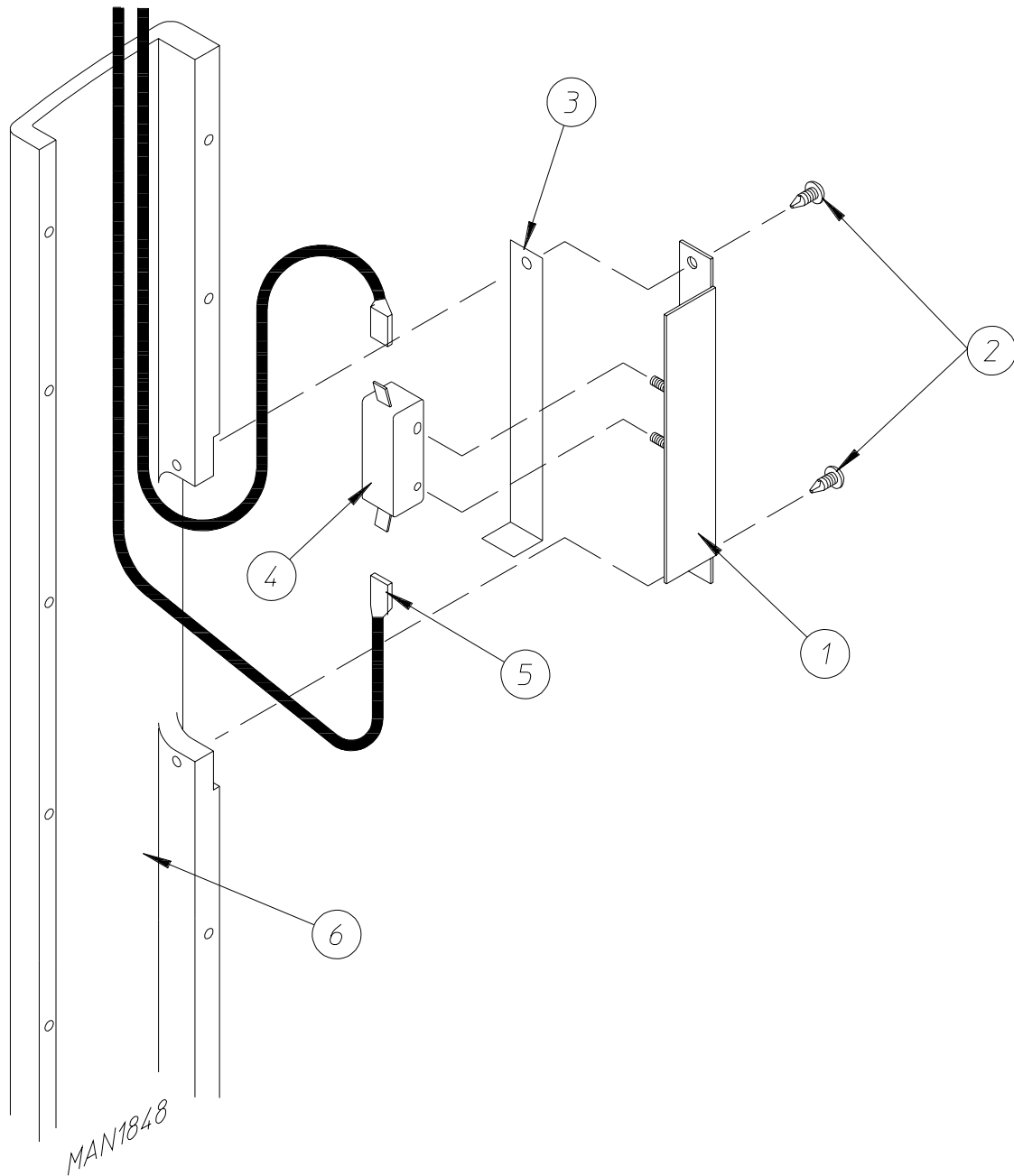

<u>Illus. No.</u>	<u>Part No.</u>	<u>Qty.</u>	<u>Description</u>
1	821097	1	Main Door Switch Bracket Assembly
2	150309	2	#10-16 x 1/2" Hex Head TEK Crimptite Screw
3	102405	1	Main Door Switch Actuator
4	137005	1	Main Door Switch ONLY
5	121028	2	1/4" x 0.032 Insulated Terminal ONLY
6	180155	1	35" ADC Gray Main Door Terminal Block ONLY

Lint Door Assembly

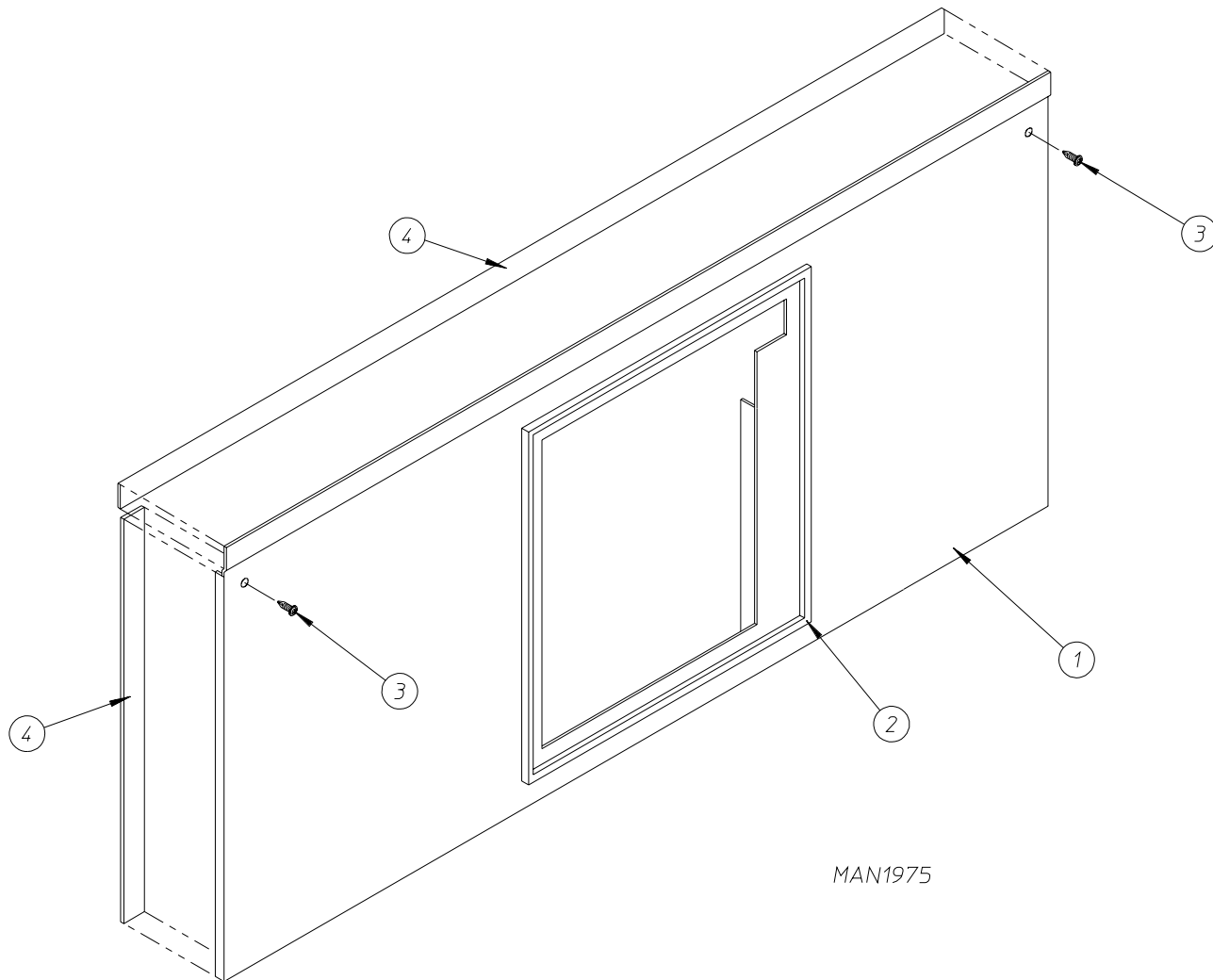

MAN1975

Illus. No.	Part No.	Qty.	Description
1*	820945	1	Lint Door Assembly (includes illus. nos. 1, 2, and 4)
2	117605	5	Neoprene Sponge Tape (sold by the foot) (for models mfd. as of August 6, 1998)
	117602	5	Noise Suppressor Tape (sold by the foot) (for models mfd. prior to August 6, 1998)
3	150309	5	#10-16 x 1/2" Hex Head TEK Crimptite Screw
4	117604	5	Neoprene Sponge Tape (sold by the foot) (for models mfd. as of August 6, 1998)
	117600	5	Noise Suppressor Tape (sold by the foot) (for models mfd. prior to August 6, 1998)

* Specify color when ordering.

Lint Drawer / Lint Drawer Switch Box Assemblies

For Models Mfd. as of August 30, 1999

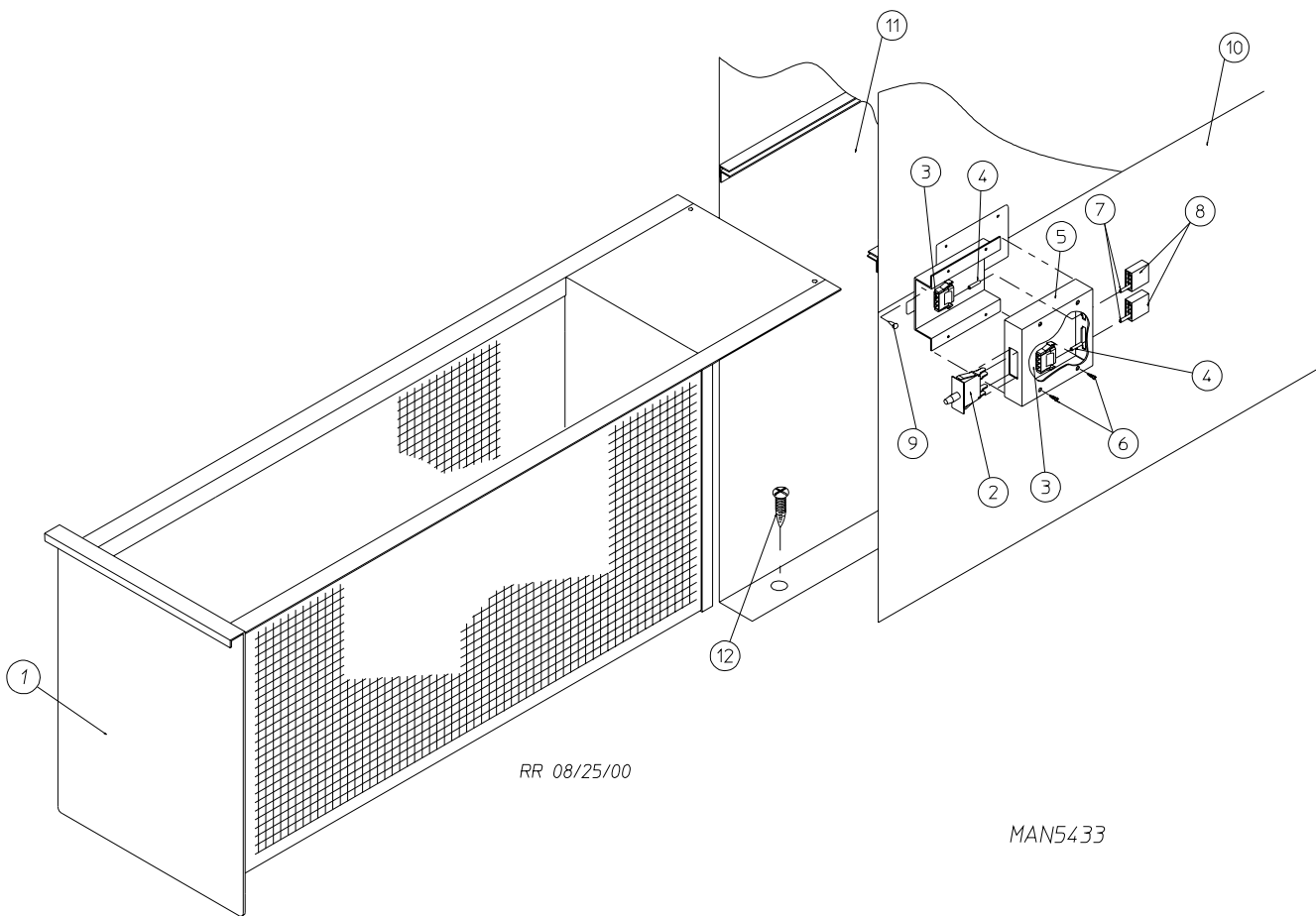

<u>Illus. No.</u>	<u>Part No.</u>	<u>Qty.</u>	<u>Description</u>
1	882792	1	White Lint Drawer / Screen Assembly
	882793	1	Coral Wrinkle Blue Lint Drawer / Screen Assembly
2	122116	1	Lint Drawer Switch ONLY
3	122605	1	4-Pin Socket Connector
4	122701	2	Socket Terminal ONLY
	122801	1	Pin / Socket Extraction Tool
5	882507	1	Lint Drawer Switch Box Assembly Complete (includes illus. nos. 3 through 6)
6	150301	4	#8-18 x 7/16" Phillips Pan Head TEK Screw
7	122700	2	Pin Terminal ONLY
8	122604	1	4-Pin Connector
9	150301	2	#8-18 x 7/16" Phillips Pan Head TEK Screw
10	319076	1	Right-Hand Divider Panel
11	319077	1	Left-Hand Divider Panel
12	150301	14	#8-18 x 7/16" Phillips Pan Head TEK Screw

Lint Drawer / Lint Drawer Switch Box Assemblies

For Models Mfd. Between December 1, 1994 and August 30, 1999

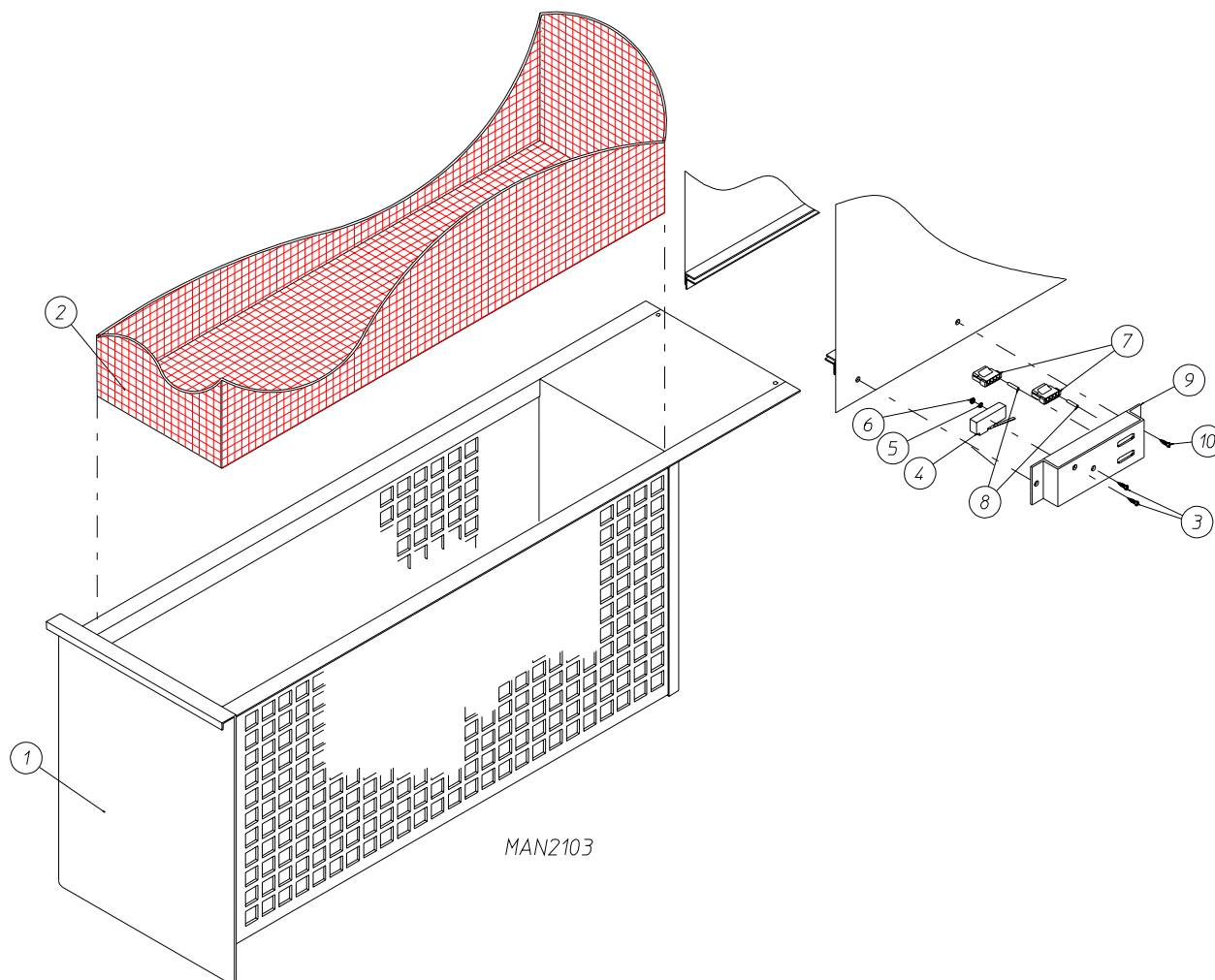

MAN2103

Illus. No.	Part No.	Qty.	Description
1*	821046	1	Lint Drawer Assembly
2	820925	1	Lint Screen Assembly ONLY
3	150002	2	#6-32 x 1" Phillips Round Head Machine Screw
4	136992	1	Lint Drawer Switch ONLY
5	153010	2	#6 Star Washer
6	152000	2	#6-32 Hex Nut
7	122605	2	4-Pin Socket Connector ONLY
8	122701	4	Socket Terminal ONLY
	122801	1	Pin / Socket Extraction Tool
9	821119	1	Lint Drawer Switch Assembly Complete (includes illus. nos. 3 through 10)
	821116	1	Lint Drawer Switch Mounting Bracket Assembly ONLY (includes illus. nos. 3 and 4)
	332348	1	Lint Drawer Switch Mounting Bracket ONLY
10	150309	2	#10-16 x 1/2" Hex Head TEK Crimptite Screw

* Specify color when ordering.

Lint Drawer / Lint Drawer Switch Box Assemblies

For Models Mfd. prior to December 1, 1994

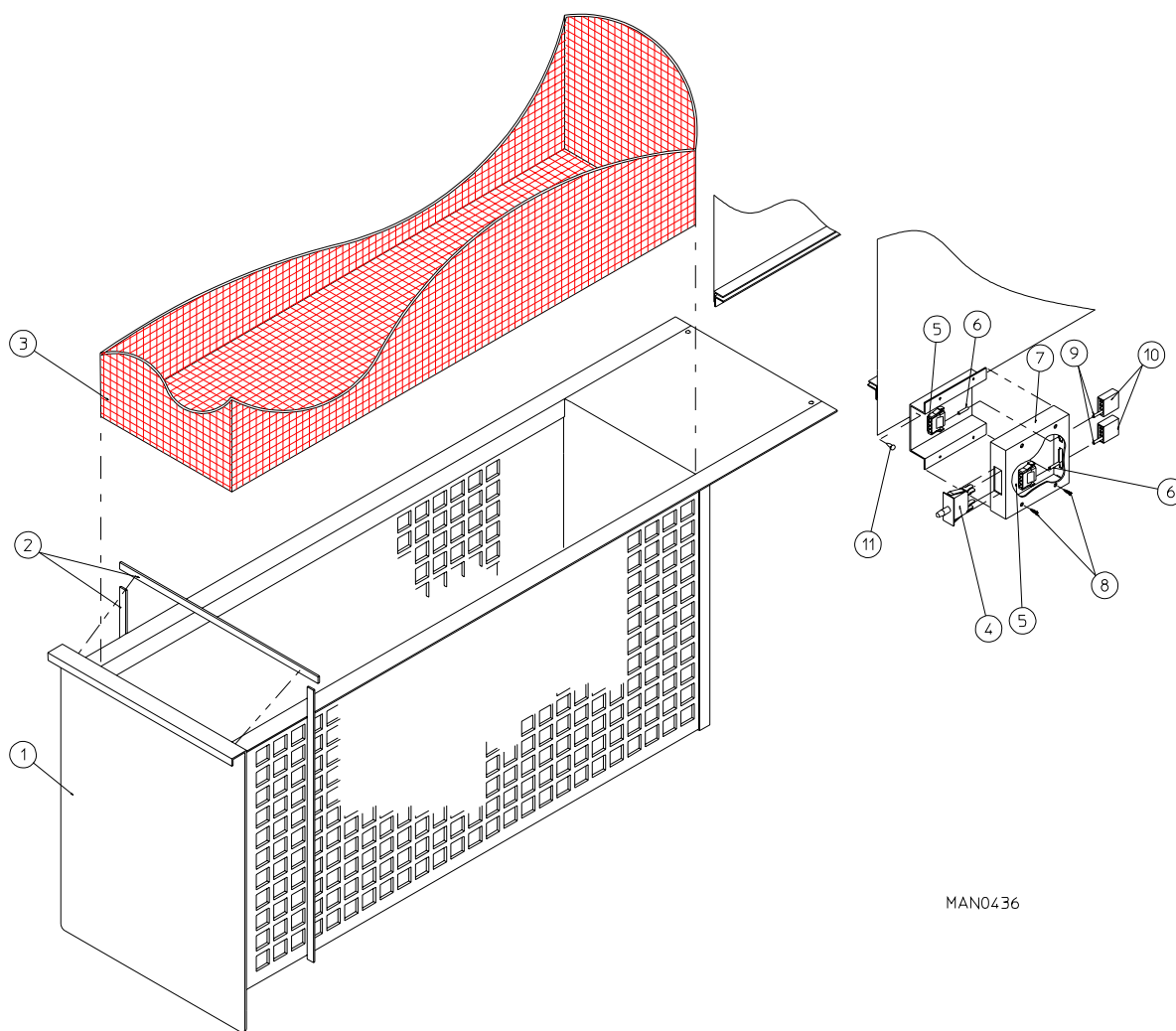

MAN0436

Illus. No.	Part No.	Qty.	Description
1*	820955	1	Lint Drawer Assembly Complete (includes illus. nos. 1 and 2)
2	117605	5	Neoprene Sponge Tape (sold by the foot) (for models mfd. as of August 6, 1998)
	117602	5	Noise Suppressor Tape (sold by the foot) (for models mfd. prior to August 6, 1998)
3	820925	1	Lint Screen Assembly ONLY
4	122116	1	Lint Drawer Switch ONLY
5	122605	2	4-Pin Socket Connector
6	122701	8	Socket Terminal ONLY
	122801	1	Pin / Socket Extraction Tool
7	800264	1	Lint Drawer Switch Box Assembly Complete (includes illus. nos. 4 through 7)
	304034	1	Lint Drawer Switch Box ONLY
8	150301	4	#8-18 x 7/16" Phillips Pan Head TEK Screw
9	122700	8	Pin Terminal ONLY
10	122604	2	4-Pin Connector
11	150301	2	#8-18 x 7/16" Phillips Pan Head TEK Screw

* Specify color when ordering.

Microprocessor Temperature Sensor Bracket Assembly

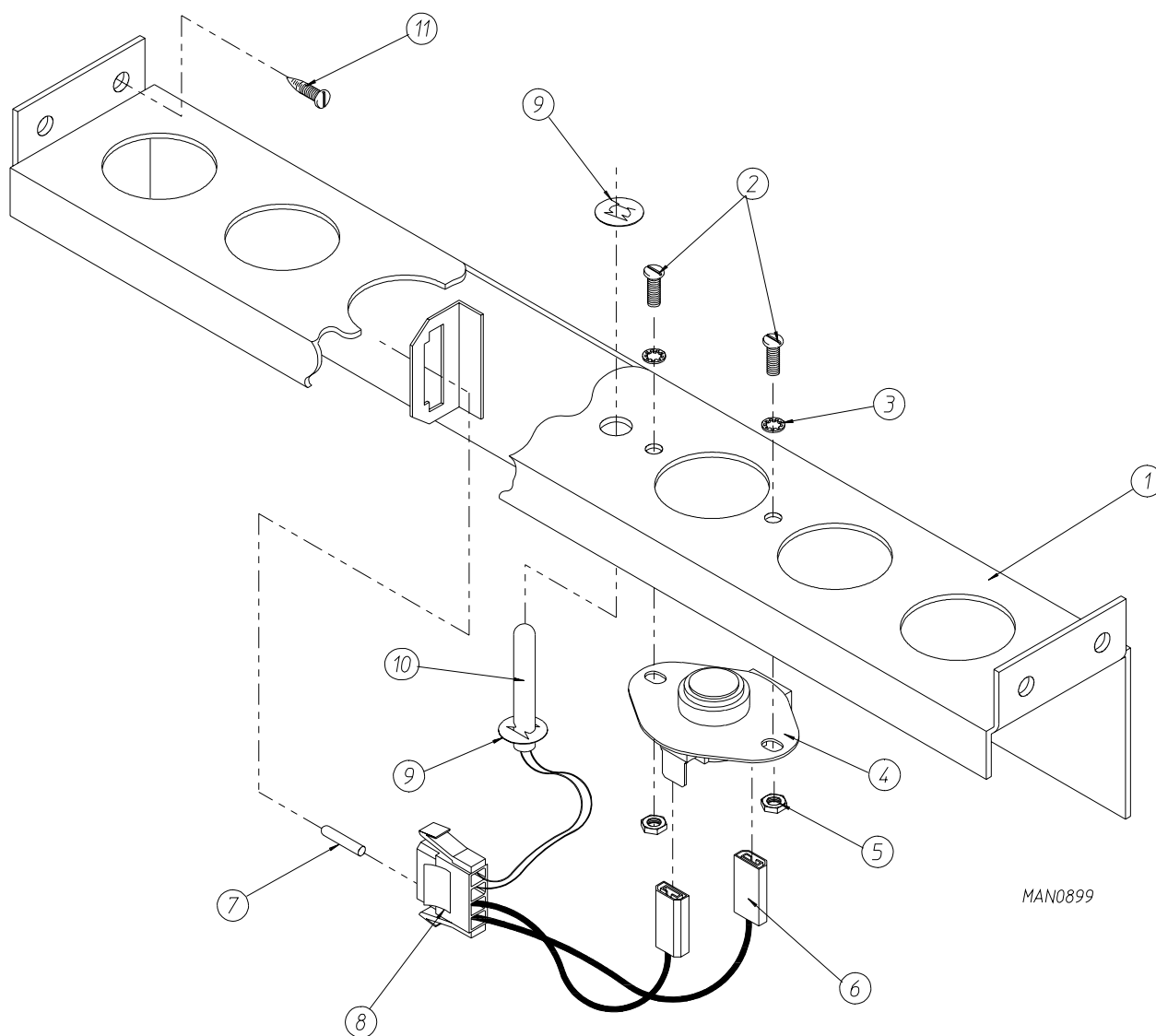

Illus. No.	Part No.	Qty.	Description
1	820968	1	Microprocessor Temperature Sensor Bracket Complete (includes illus. nos. 1 through 10)
	820967	1	Microprocessor Temperature Sensor Bracket ONLY
2	150005	2	#6-32 x 1/4" Phillips Round Head Machine Screw
3	153010	2	#6 Star Washer
4	130112	1	225° Large Automatic Reset Thermostat ONLY
5	152000	2	#6-32 Hex Nut
6	121028	2	1/4" x 0.032 Insulated Terminal
7	122701	4	Socket Terminal ONLY
	122801	1	Pin / Socket Extraction Tool
8	122605	1	4-Pin Socket Connector
9	154007	2	1/4" Push-On Fastener
10	880251	1	1/4" Temperature Sensor Probe Assembly (includes illus. nos. 6 through 10)
11	150301	4	#8-18 x 7/16" Phillips Pan Head TEK Screw

Timer Temperature Sensor Bracket Assembly

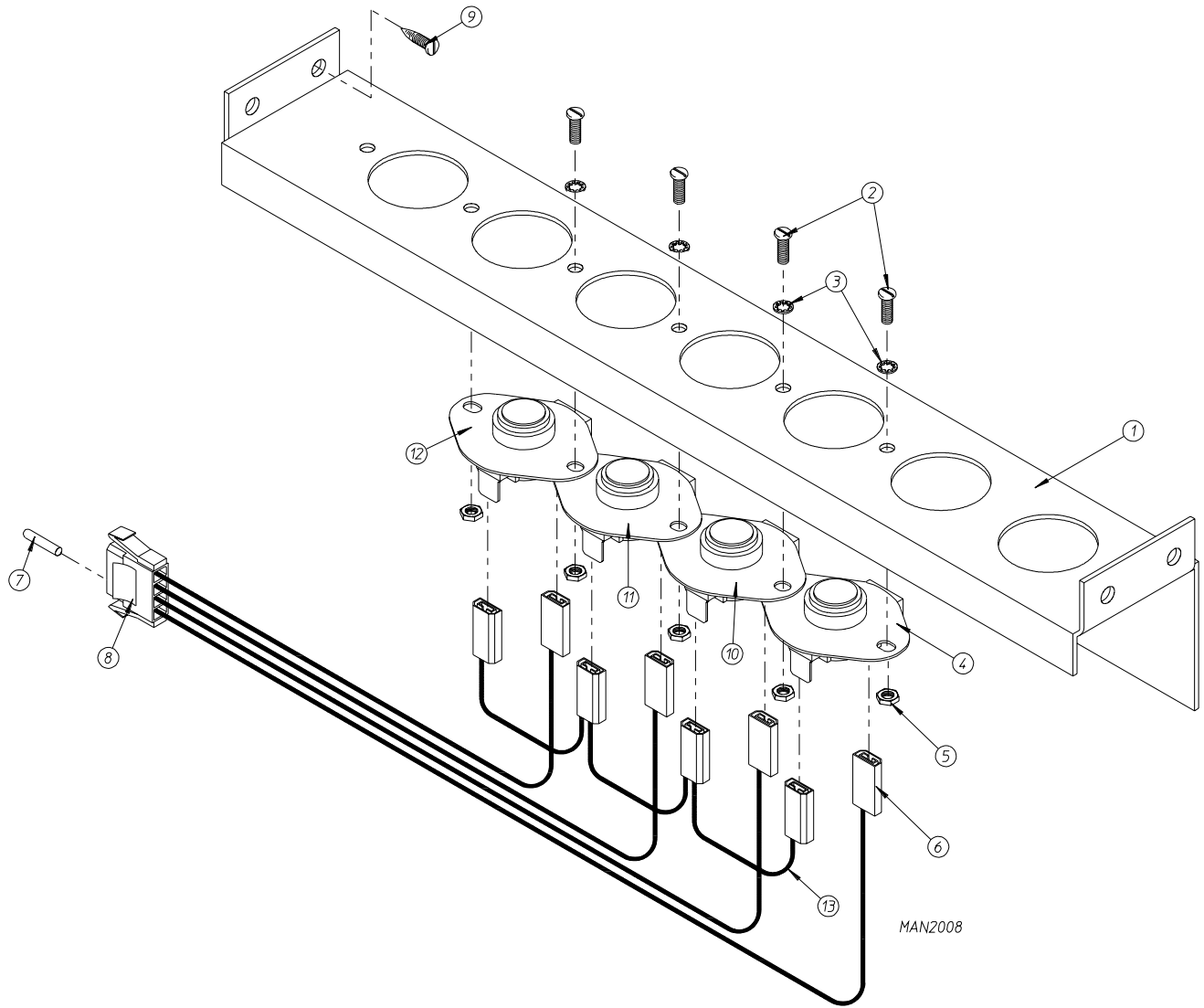

Illus. No.	Part No.	Qty.	Description
1	821016	1	Timer Temperature Sensor Bracket Complete (includes illus. nos. 1 through 13)
	820999	1	Timer Temperature Sensor Bracket ONLY
2	150005	5	#6-32 x 1/4" Round Head Machine Screw
3	153010	5	#6 Star Washer
4	130101	1	180° Large Thermostat ONLY
5	152000	5	#6-32 Hex Nut
6	121028	4	1/4" x 0.032 Insulated Terminal
7	122701	4	Socket Terminal ONLY
	122801	1	Pin / Socket Extraction Tool
8	122605	1	4-Pin Socket Connector
9	150301	4	#8-18 x 7/16" Phillips Pan Head TEK Screw
10	130109	1	140° Large Thermostat ONLY
11	130107	1	160° Large Thermostat ONLY
12	130103	1	225° Large Automatic Reset Thermostat ONLY
13	831701	1	Sensor Jumper (4) ONLY

Tumbler / Support Assemblies

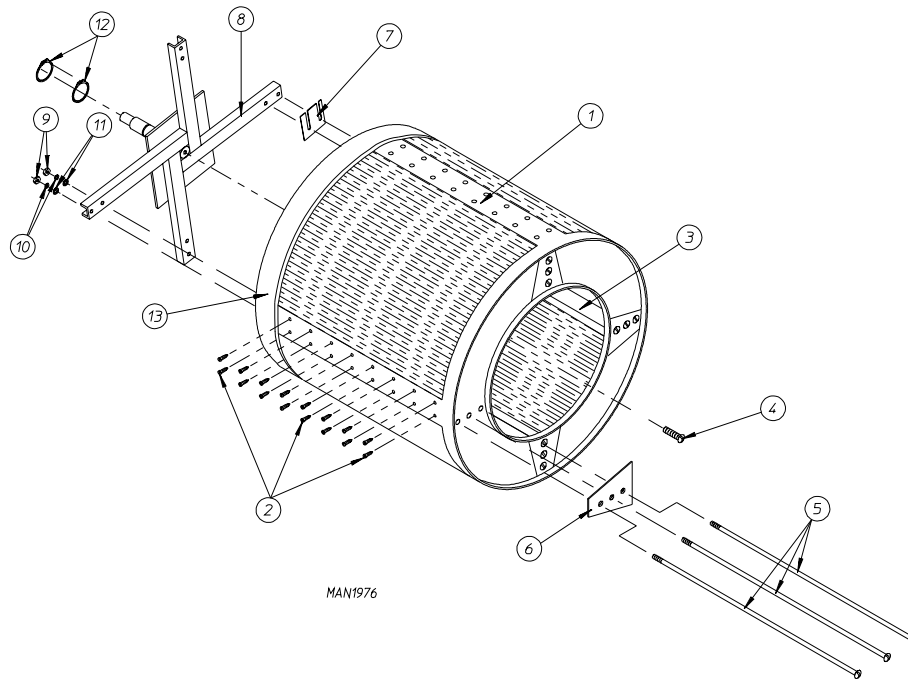

Illus. No.	Part No.	Qty.	Description
1	820979*	1	Galvanized Tumbler ONLY without Felt Collar
	881639	1	Galvanized Tumbler and Support Assembly Complete (for models mfd. as of August 27, 1997) (includes illus. nos. 1 through 13)
	821001	1	Galvanized Tumbler and Support Assembly Complete (for models mfd. prior to August 27, 1997) (includes illus. nos. 1 through 13)
	820927	1	Galvanized Tumbler and Support Assembly Complete (includes illus. nos. 1 through 13)
	881640	1	Stainless Steel Tumbler and Support Assembly Complete (for models mfd. as of August 27, 1997) (includes illus. nos. 1 through 13)
	821023	1	Stainless Steel Tumbler and Support Assembly Complete (for models mfd. prior to August 27, 1997) (includes illus. nos. 1 through 13)
2	150309	64	#10-16 x 1/2" Hex Head TEK Crimptite Screw
3	332140	4	Galvanized Tumbler Rib ONLY
4	150500	1	5/16-18 x 3/4" Socket Button Head Screw
5	100910	12	1/2-13 x 44" Tie Rod
6	332139	4	Tumbler Reinforcing Plate ONLY
7	332177	**	Tumbler Shim ONLY
8	881555	1	Tumbler Support ONLY (for models mfd. as of August 27, 1997)
	820909	1	Tumbler Support ONLY (for models mfd. prior to August 27, 1997)
9	152009	12	1/2-13 Hex Nut
10	153013	12	1/2" Lock Washer
11	153014	12	9/16" Flat Washer
12	100810	***	3-1/8" Retaining Ring
13	116007	1	Felt Collar ONLY

* Felt collar is not included and must be ordered separately.

** As required.

*** One piece for models mfd. as of August 27, 1997. Two pieces for models mfd. prior to August 27, 1997.

Tumbler Bearing Mount Assembly

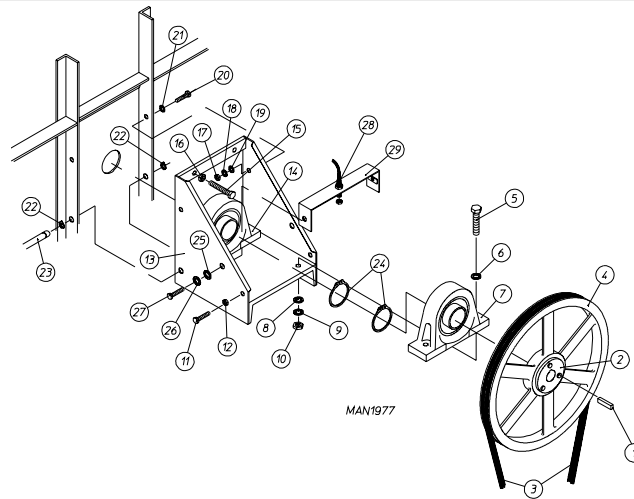

<u>Illus. No.</u>	<u>Part No.</u>	<u>Qty.</u>	<u>Description</u>
1	100703	1	1/2" x 1/2" x 2" Key
2	101217	1	2-1/2" SFX Bushing with Key (for models mfd. as of August 27, 1997)
	101137	1	2-1/4" SFX Bushing (for models mfd. prior to August 27, 1997)
3*	100137	2	AB-91 V-Belt (tumbler to idler)
4	101182	1	25" Tumbler Pulley ONLY
5	150602	4	5/8-11 x 3" Hex Head Machine Bolt
6	153016	4	5/8" Flat Washer
7	100242	1	2-1/2" Pillow Block Bearing ONLY (for models mfd. as of August 27, 1997)
	880883	1	3-1/8" Pillow Block Bearing ONLY (for models mfd. prior to August 27, 1997)
8	153016	4	5/8" Flat Washer
9	153015	4	5/8" Lock Washer
10	152010	4	5/8-11 Hex Nut
11	150600	2	3/8-16 x 1-1/2" Hex Head Machine Bolt
12	152005	2	3/8-16 Hex Nut
13	821175	1	Tumbler Bearing Mount ONLY (for models mfd. as of August 27, 1997)
	820910	1	Tumbler Bearing Mount ONLY (for models mfd. prior to August 27, 1997)
14	880883	1	3-1/8" Pillow Block Bearing ONLY
15	150603	2	1/2-13 x 3" Square Head Machine Bolt
16	152011	2	1/2-13 Hex Nut
17	152005	2	3/8-16 Hex Nut
18	153005	2	3/8" Lock Washer
19	153004	4	3/8" Flat Washer
20	150600	2	3/8-16 x 1-1/2" Hex Head Machine Bolt
21	153004	2	3/8" Flat Washer
22	100801	2	5/8" Retaining Ring
23	332153	1	5/8" Hinge Pin
24	100810	**	1/8" Retaining Ring
25	153018	2	1/4" Flat Washer
26	153007	2	1/4" Lock Washer
27	150512	2	1/4-20 x 1/2" Hex Head Machine Bolt
28	824807	1	Rotational Sensor Assembly
29	880841	1	Rotational Sensor Mounting Bracket

* Replace in matched sets (both belts).

** One piece for models mfd. as of August 27, 1997. Two pieces for models mfd. prior to August 27, 1997.

Idler Bearing Mount Assembly

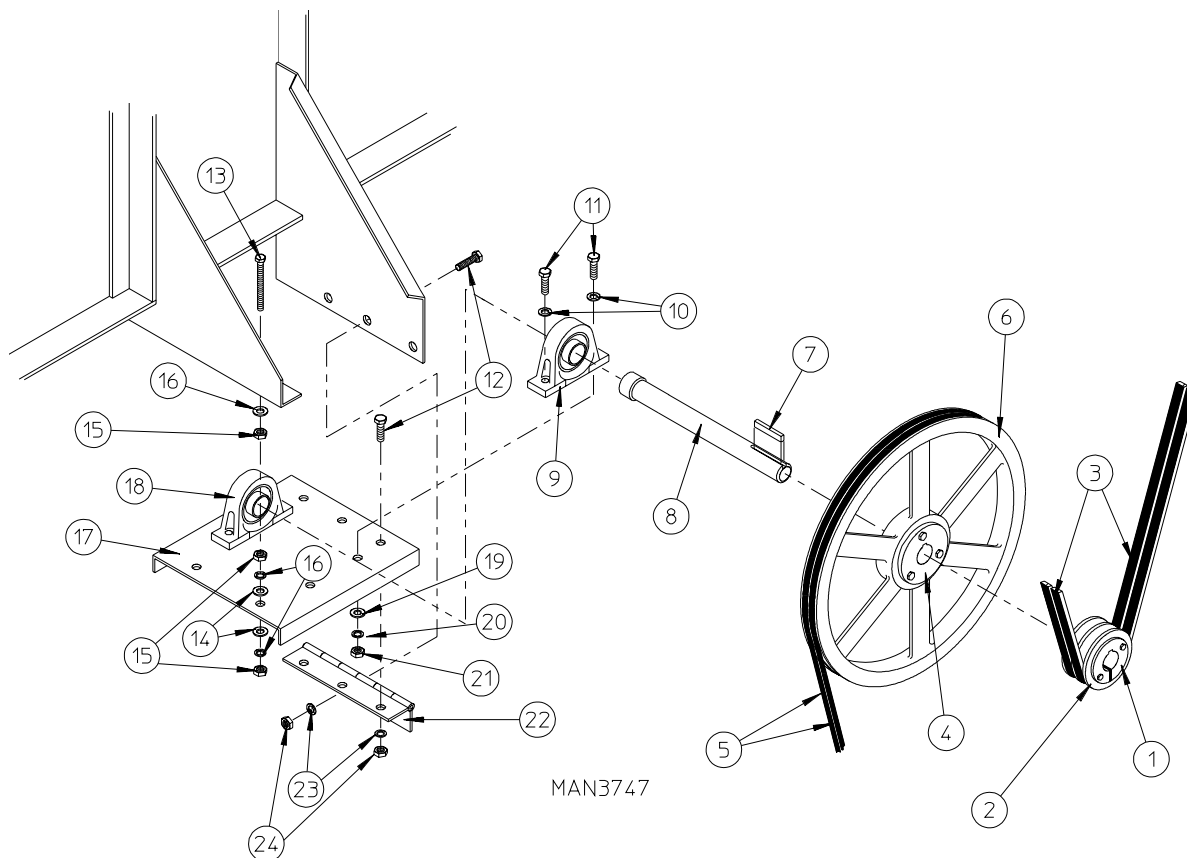

Illus. No.	Part No.	Qty.	Description
1	101152	1	1-3/8" Bushing
2	101143	1	2A3.8 Pulley
3*	100137	2	AB-91 V-Belt (tumbler to idler)
4	101184	1	1-3/8" SK Bushing
5*	100102	2	3V-740 V-Belt (idler to motor)
6	101112	1	19" Idler Pulley
7	100715	1	1/4" x 1/4" x 4-5/8" Key
8	332152	1	1-3/8" Idler Shaft ONLY
9	880879	1	1-3/8" Pillow Block Bearing
10	150501	4	5/16" Flat Washer
11	150606	4	1/2-13 Hex Head Machine Bolt
12	150501	6	5/16-18 x 3/4" Hex Head Machine Bolt
13	150509	2	5/16-18 x 3" Hex Head Machine Bolt
14	153002	6	5/16" Flat Washer
15	152004	6	5/16-18 Hex Nut
16	153002	4	5/16" Lock Washer
17	820932	1	Idler Bearing Mount Assembly Complete (includes illus. nos. 7 through 11 and 17 through 24)
	311401	1	Idler Bearing Mount ONLY
18	880879	1	1-3/8" Pillow Block Bearing
19	153011	4	Flat Washer 9/16" ID, 1-3/8" OD
20	153026	4	1/2" Lock Washer
21	152011	4	1/2-13 Hex Nut
22	103005	1	Idler Adjustment Hinge ONLY
23	153002	6	5/16" Lock Washer
24	152004	6	5/16-18 Hex Nut

* Replace in matched sets (both belts).

T.E.F.C. Tumbler Motor Mount Assembly

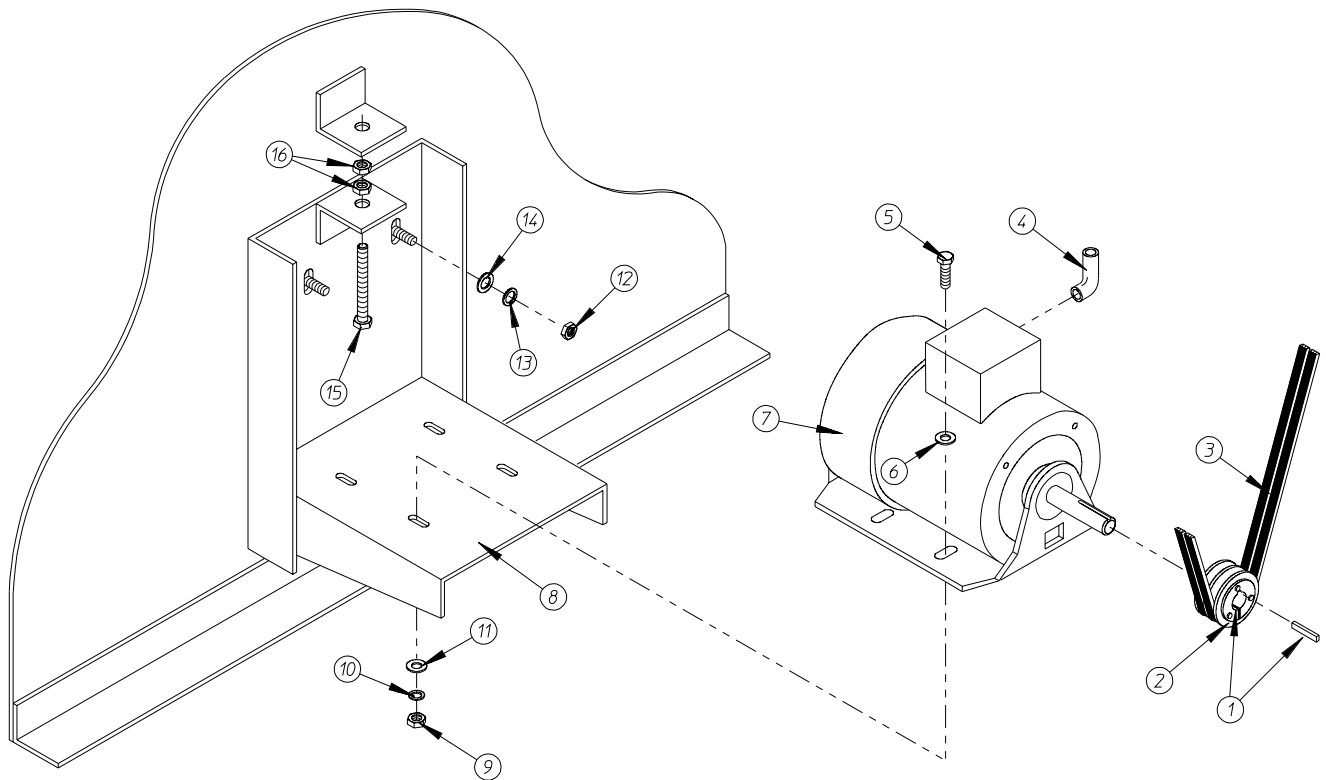

MAN0329

Illus. No.	Part No.	Qty.	Description
1	101121	1	5/8" SK Bushing
2	101114	1	2.65" Pulley (for 60 Hz models Only)
	101120	1	3.15" Pulley (for 50 Hz models Only)
3*	100102	2	3V-740 V-Belt (motor to idler)
4	120200	1	3/8" x 90° Connector
5	150501	4	5/16-18 x 3/4" Hex Head Machine Bolt
6	153001	4	5/16" Flat Washer
7	100050	1	1 hp 208/230/380/460v 3Ø 50/60 Hz Totally Enclosed, Fan-Cooled Motor (56Z frame)
8	800952	1	Tumbler Motor Mount ONLY (56Z frame)
	820941**	1	(50/60 Hz) Totally Enclosed, Fan-Cooled Tumbler Motor Mount Assembly Complete (includes illus. nos. 1, 4 through 11, 15, and 16) NOTE: Motor pulley must be ordered separately
9	152004	4	5/16-18 Hex Nut
10	153002	4	5/16" Lock Washer
11	153001	4	5/16" Flat Washer
12	152004	4	5/16-18 Hex Nut
13	153002	4	5/16" Lock Washer
14	153001	4	5/16" Flat Washer
15	150619	1	3/8-16 x 3" Hex Head Machine Bolt
16	152005	2	3/8-16 Hex Nut

* Replace in matched sets (both belts).

** Specify color when ordering.

IMPORTANT: For voltages higher than 460V, contact the factory for correct part number of motor or motor mount assembly.

Blower Motor Mount Assembly

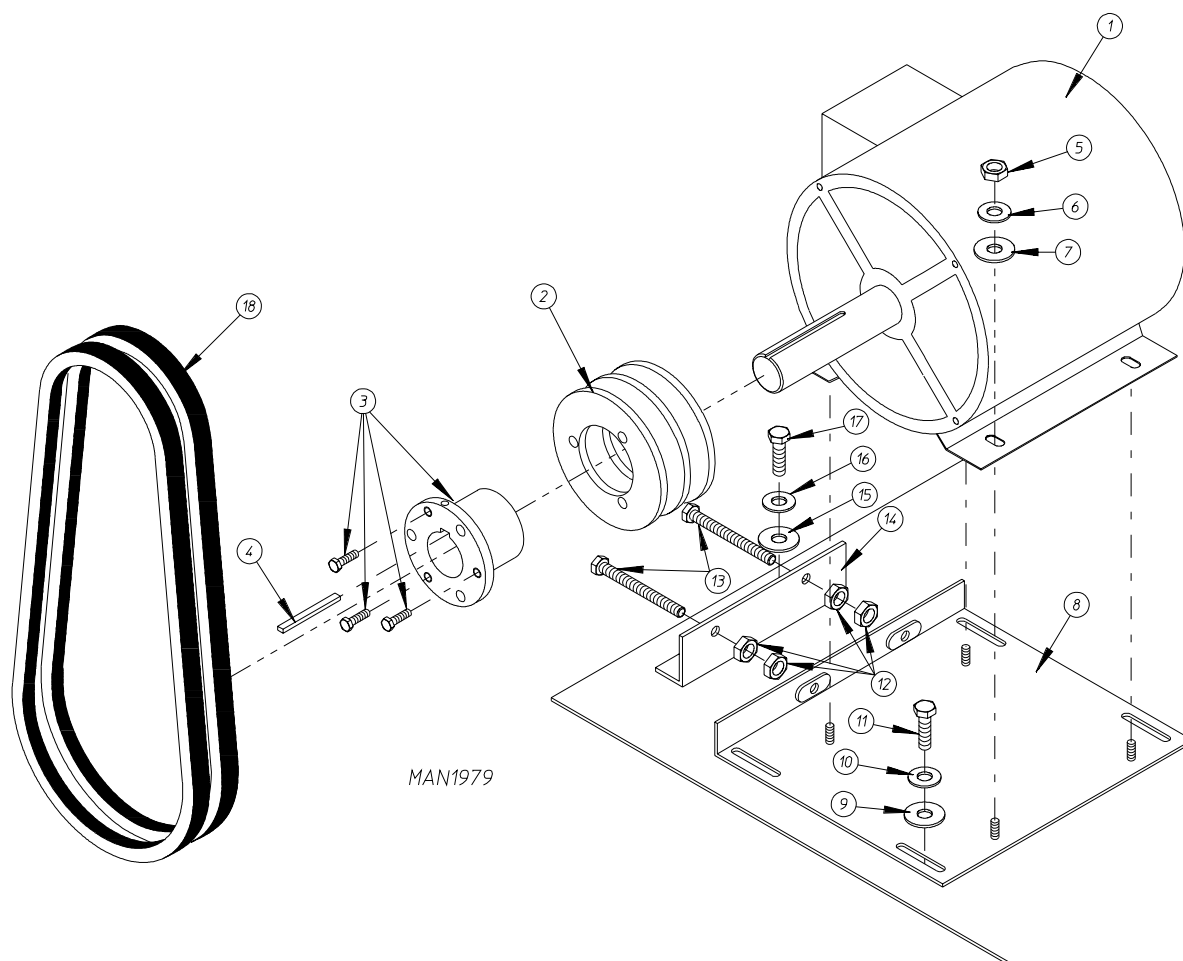

Illus. No.	Part No.	Qty.	Description
1	100046	1	7.5 hp 208-230/460v / 3 ϕ Motor (for 60 Hz models Only)
	100092	1	7.5 hp 230/460v / 3 ϕ Motor (for 50 Hz models Only)
2	101148	1	SB x 4.0 Motor Pulley (for 60 Hz models Only)
	101147	1	SB x 4.8 Motor Pulley (for 50 Hz models Only)
3	101152	1	SH x 1-3/8" Bushing (for 60 Hz models Only)
	101194	1	SDS x 1-3/8" Bushing (for 50 Hz models Only)
4	100706	1	5/16" x 5/16" x 1-3/8" Key
5	152004	4	5/16-18 Hex Nut
6	153002	4	5/16" Lock Washer
7	153001	4	5/16" Flat Washer
8	821091	1	Motor Mount Adjustment Plate ONLY
9	153001	4	5/16" Flat Washer
10	153002	4	5/16" Lock Washer
11	150501	4	5/16-18 x 3/4" Hex Head Machine Bolt
12	152004	4	5/16-18 Hex Nut
13	150503	2	5/16-18 x 2" Hex Head Machine Bolt
14	332322	1	Motor Mount Adjustment Angle ONLY
15	153001	2	5/16" Flat Washer
16	153002	2	5/16" Lock Washer
17	150501	2	5/16-18 x 3/4" Hex Head Machine Bolt
18*	100128	2	BX-50 Cogged Belt (motor to fan shaft) for 60 Hz Models ONLY
	100164	2	BX-51 Cogged Belt (motor to fan shaft) for 50 Hz Models ONLY

* Replace in matched sets (both belts).

Fan Shaft Mount Assembly

For Gas Models Only

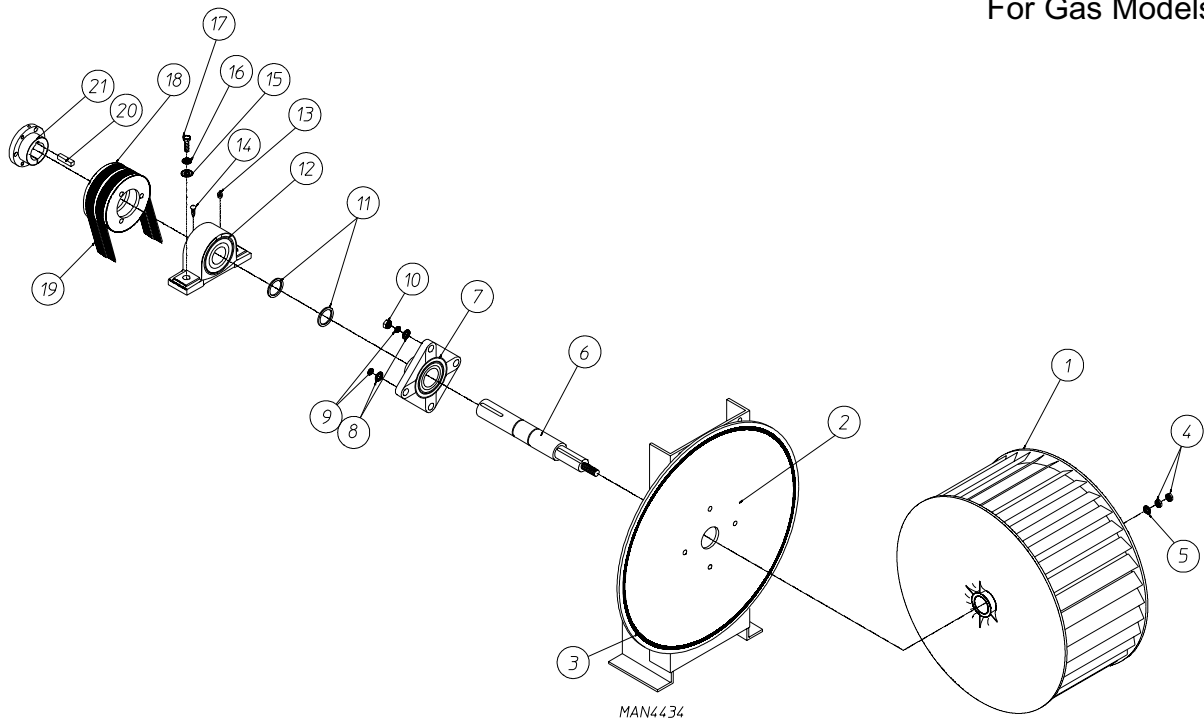

Illus. No.	Part No.	Qty.	Description
1	100612	1	1-1/4" Bore x 15" Diameter x 6" Blower (fan) Wheel
2	821078	1	Fan Shaft Mount Assembly Complete (includes illus. nos. 1 through 21)
	821073	1	Fan Shaft Mount ONLY
3	117604	4	Neoprene Sponge Tape (sold by the foot) (for models mfd. as of August 8, 1998)
	117600	4	Noise Suppressor Tape (sold by the foot) (for models mfd. prior to August 8, 1998)
4	152006	2	1/2-20 Left-Hand Jam Nut
5	153050	1	1/2" Flat Washer
6	332280	1	Fan Shaft ONLY
7	881061	1	1-3/8" Flange Bearing with Setscrew and Grease Fitting
8	153004	4	3/8" Flat Washer
9	153005	4	3/8" Lock Washer
10	152005	4	3/8-16 Hex Nut
11	100812	2	1-3/8" Retaining Ring
12	880879	1	1-3/8" Pillow Block Bearing ONLY (includes illus. nos. 12 through 14)
13	170511	2	1/8-27 N.P.T. ZIRC Grease Fitting ONLY or
	170512	2	1/4-28 Tapered ZIRC Grease Fitting ONLY
14	154326	4	5/16-24 x 3/8" Cone Point Setscrew
15	153004	2	3/8" Flat Washer
16	153005	2	3/8" Lock Washer
17	150617	2	#3-16 x 1" Hex Head Bolt
18	101177	1	2B x 5.8 Pulley
19*	100128	2	BX-50 Cogged Belt (fan shaft to motor) for 60 Hz Models ONLY
	100164	2	BX-51 Cogged Belt (fan shaft to motor) for 50 Hz Models ONLY
20	100706	1	5/16" x 5/16" x 1-3/8" Key
21	101194	1	SDS x 1-3/8" Bushing ONLY

* Replace in matched sets (both belts).

Fan Shaft Mount Assembly

For Steam Models Only

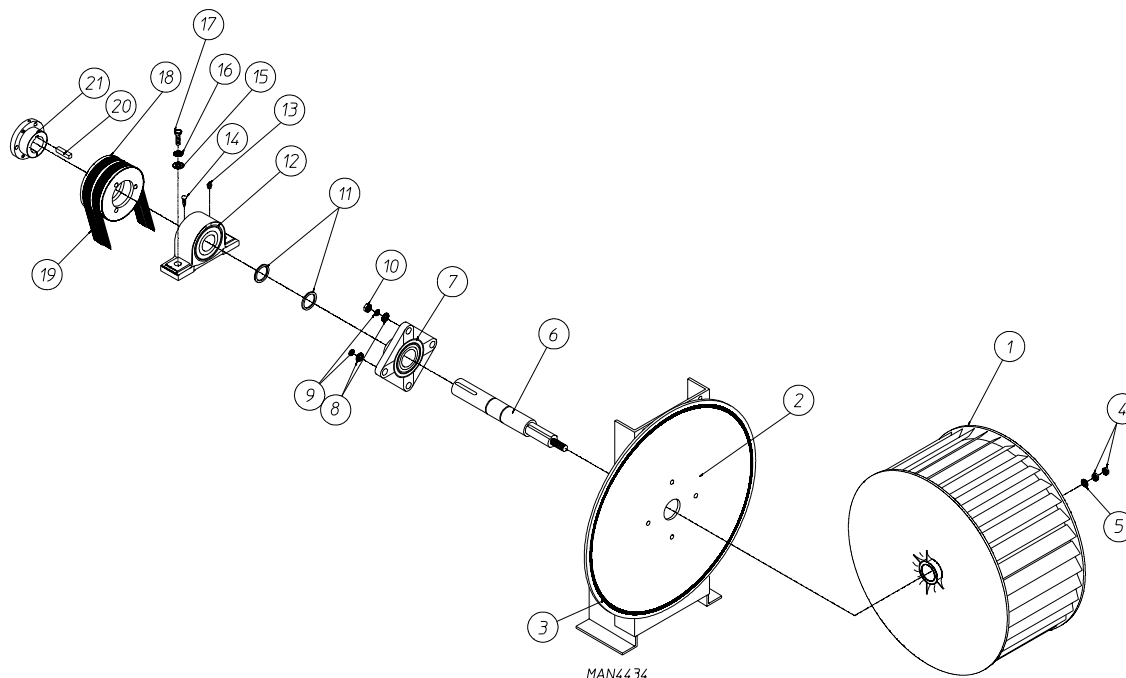

Illus. No.	Part No.	Qty.	Description
1	100612	1	1-1/4" Bore x 15" Diameter x 6" Blower (fan) Wheel
2	821077	1	Fan Shaft Mount Assembly Complete (includes illus. nos. 1 through 21)
	821073	1	Fan Shaft Mount ONLY
3	117604	4	Neoprene Sponge Tape (sold by the foot) (for models mfd. as of August 8, 1998)
	117600	4	Noise Suppressor Tape (sold by the foot) (for models mfd. prior to August 8, 1998)
4	152006	2	1/2-20 Left-Hand Jam Nut
5	153050	1	1/2" Flat Washer
6	332280	1	Fan Shaft ONLY
7	881061	1	1-3/8" Flange Bearing with Setscrew and Grease Fitting
8	153004	4	3/8" Flat Washer
9	153005	4	3/8" Lock Washer
10	152005	4	3/8-16 Hex Nut
11	100812	2	1-3/8" Retaining Ring
12	880879	1	1-3/8" Pillow Block Bearing ONLY (includes illus. nos. 12 through 14)
13	170511	2	1/8-27 N.P.T. ZIRC Grease Fitting ONLY or
	170512	2	1/4-28 Tapered ZIRC Grease Fitting ONLY
14	154326	4	5/16-24 x 3/8" Cone Point Setscrew
15	153004	2	3/8" Flat Washer
16	153005	2	3/8" Lock Washer
17	150617	2	#3-16 x 1" Hex Head Bolt
18	101135	1	2B x 5.4 Pulley
19*	100128	2	BX-50 Cogged Belt (fan shaft to motor) for 60 Hz Models ONLY
	100164	2	BX-51 Cogged Belt (fan shaft to motor) for 50 Hz Models ONLY
20	100706	1	5/16" x 5/16" x 1-3/8" Key
21	101194	1	SDS x 1-3/8" Bushing ONLY

* Replace in matched sets (both belts).

Direct Spark Ignition Burner Assembly

For Models Using Natural Gas Only

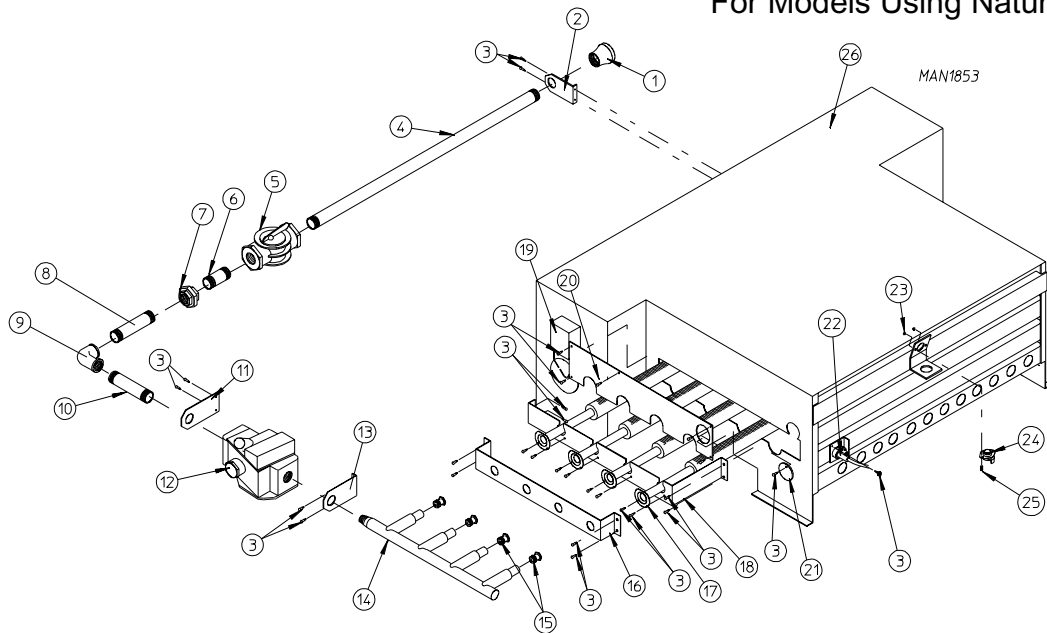

Illus. No.	Part No.	Qty.	Description
1	142929	1	1-1/2" to 1" Reducing Coupling
2	332117	1	Pipe Bracket
3	150309	31	#10-16 x 1/2" Hex Head TEK Crimptite Screw
4	142817	1	1" x 28-1/2" Pipe
5	141302	1	1" Union Shutoff
6	142724	1	1" x 2" Nipple
7	142602	1	1" Union
8	142581	1	1" x 5" Nipple
9	142548	1	1" x 90° Elbow
10	142581	1	1" x 5" Nipple
11	332487	1	Gas Valve Pipe Bracket
12	140017	1	Direct Spark Ignition 1" 24 VAC Redundant (natural gas) Gas Valve ONLY
13	332486	1	Gas Valve Pipe Bracket
14	141240	1	4-Port Manifold ONLY
15*	140839	4	#2 Burner Orifice (natural gas) ONLY
16	332114	1	Manifold Support ONLY
17	141110	4	Burner Tube ONLY
18	332121	1	Burner Tube Support ONLY
19	—	1	Sail Switch (refer to Sail Switch Assembly on page 31)
20	332113	1	Burner Box Cover Plate ONLY
21	331290	1	Ignitor / Flame-Probe Sight Hole Disc ONLY
22	128915	1	PSE-AD1 Ignitor / Flame-Probe ONLY
	880325	1	Ignitor / Flame-Probe Assembly Kit (includes high voltage wire and connector)
	880330	1	Direct Spark Ignition Ignitor High Voltage Wire / Connector ONLY
	305412	1	Direct Spark Ignition Ignitor Gap Feeler Gauge ... Not Illustrated
23	151000	2	#6-32 Pal Nut
24	130201	1	330° Hi-Limit ONLY
25	151001	2	#6-32 x 1/2" Round Head Machine Screw
26	821106**	1	Natural Gas Direct Spark Ignition Burner Assembly Complete Less Orifices (includes illus. nos. 1 through 14 and 16 through 26)
	820987	1	Burner Box ONLY

* Consult factory for elevations over 2,000 feet.

** Orifices are not included and must be ordered separately.

Direct Spark Ignition Burner Assembly

For Models Using Liquid Propane Gas Only

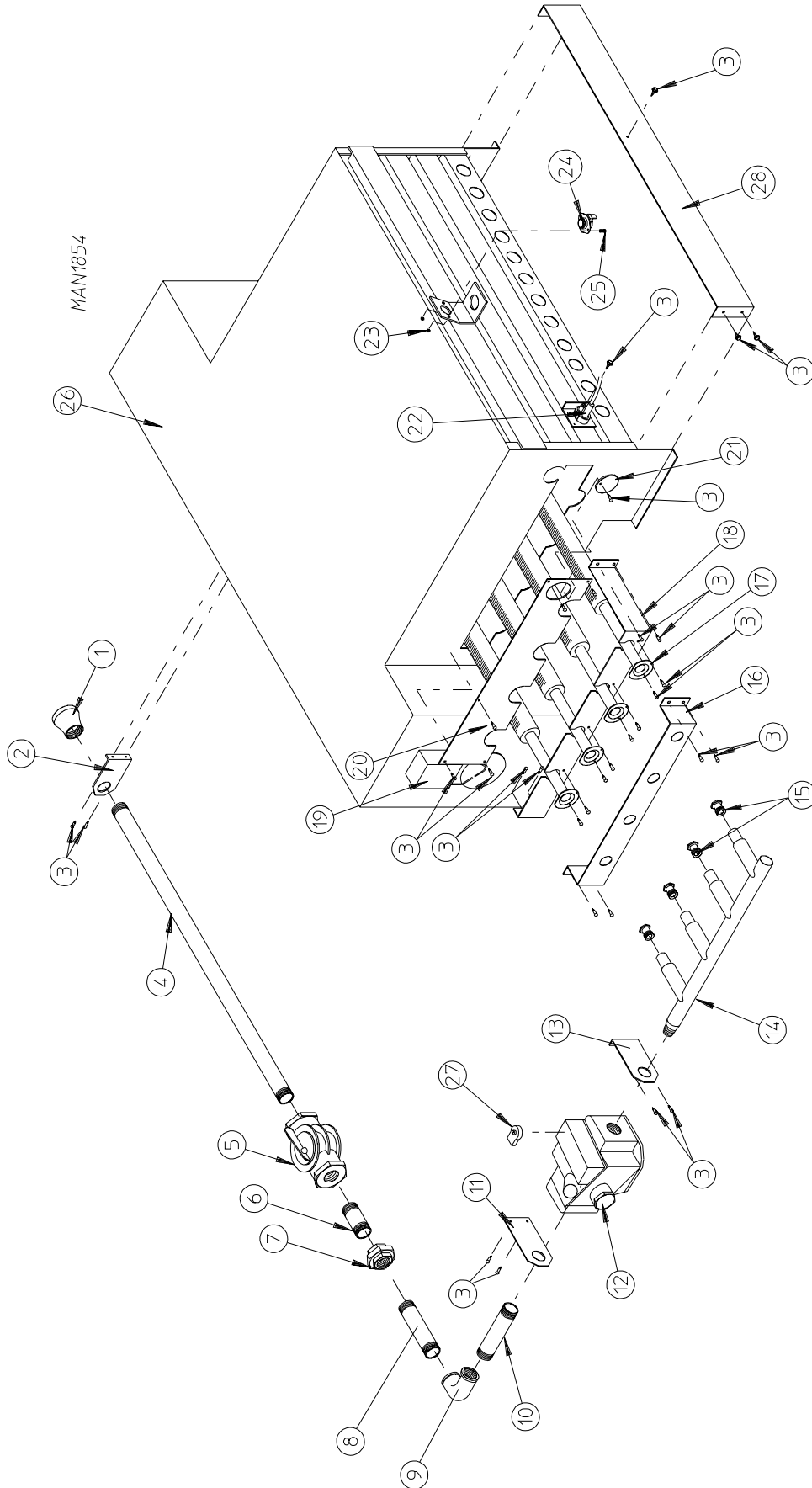

Direct Spark Ignition Burner Assembly

For Models Using Liquid Propane Gas Only

<u>Illus. No.</u>	<u>Part No.</u>	<u>Qty.</u>	<u>Description</u>
1	142929	1	1-1/2" to 1" Reducing Coupling
2	332117	1	Pipe Bracket
3	150309	36	#10-16 x 1/2" Hex Head TEK Crimptite Screw
4	142817	1	1" x 28-1/2" Pipe
5	141302	1	1" Union Shutoff
6	142724	1	1" x 2" Nipple
7	142602	1	1" Union
8	142581	1	1" x 5" Nipple
9	142548	1	1" x 90° Elbow
10	142581	1	1" x 5" Nipple
11	332487	1	Gas Valve Pipe Bracket
12	140017	1	Direct Spark Ignition 1" 24 VAC Redundant (natural gas) Gas Valve ONLY
	140018	1	1" 24 VAC Gas Valve Liquid Propane Conversion Kit
13	332486	1	Gas Valve Pipe Bracket
14	141240	1	4-Port Manifold ONLY
15*	140820	4	#29 Burner Orifice (liquid propane gas) ONLY
16	332114	1	Manifold Support ONLY
17	141110	4	Burner Tube ONLY
18	332121	1	Burner Tube Support ONLY
19	—	1	Sail Switch (refer to Sail Switch Assembly on page 31)
20	332113	1	Burner Box Cover Plate ONLY
21	331290	1	Ignitor / Flame-Probe Sight Hole Disc ONLY
22	128915	1	PSE-AD1 Ignitor / Flame-Probe ONLY
	880325	1	Ignitor / Flame-Probe Assembly Kit (includes high voltage wire and connector)
	880330	1	Direct Spark Ignition Ignitor High Voltage Wire / Connector ONLY
	305410	1	Direct Spark Ignition Ignitor Gap Feeler Gauge ... Not Illustrated
23	151000	2	#6-32 PaI Nut
24	130201	1	330° Hi-Limit ONLY
25	151001	2	#6-32 x 1/2" Round Head Machine Screw
26	821107**	1	Liquid Propane Direct Spark Ignition Burner Assembly Complete Less Orifices (includes illus. nos. 1 through 14 and 16 through 27)
	820987	1	Burner Box ONLY
27	332256	1	Liquid Propane Burner Baffle Kit ONLY
—	880978**	1	Direct Spark Ignition Liquid Propane Conversion Kit

* Consult factory for elevations over 2,000 feet.

** Orifices are not included and must be ordered separately.

Direct Spark Ignition Module Mount Assembly

For Gas Models Only

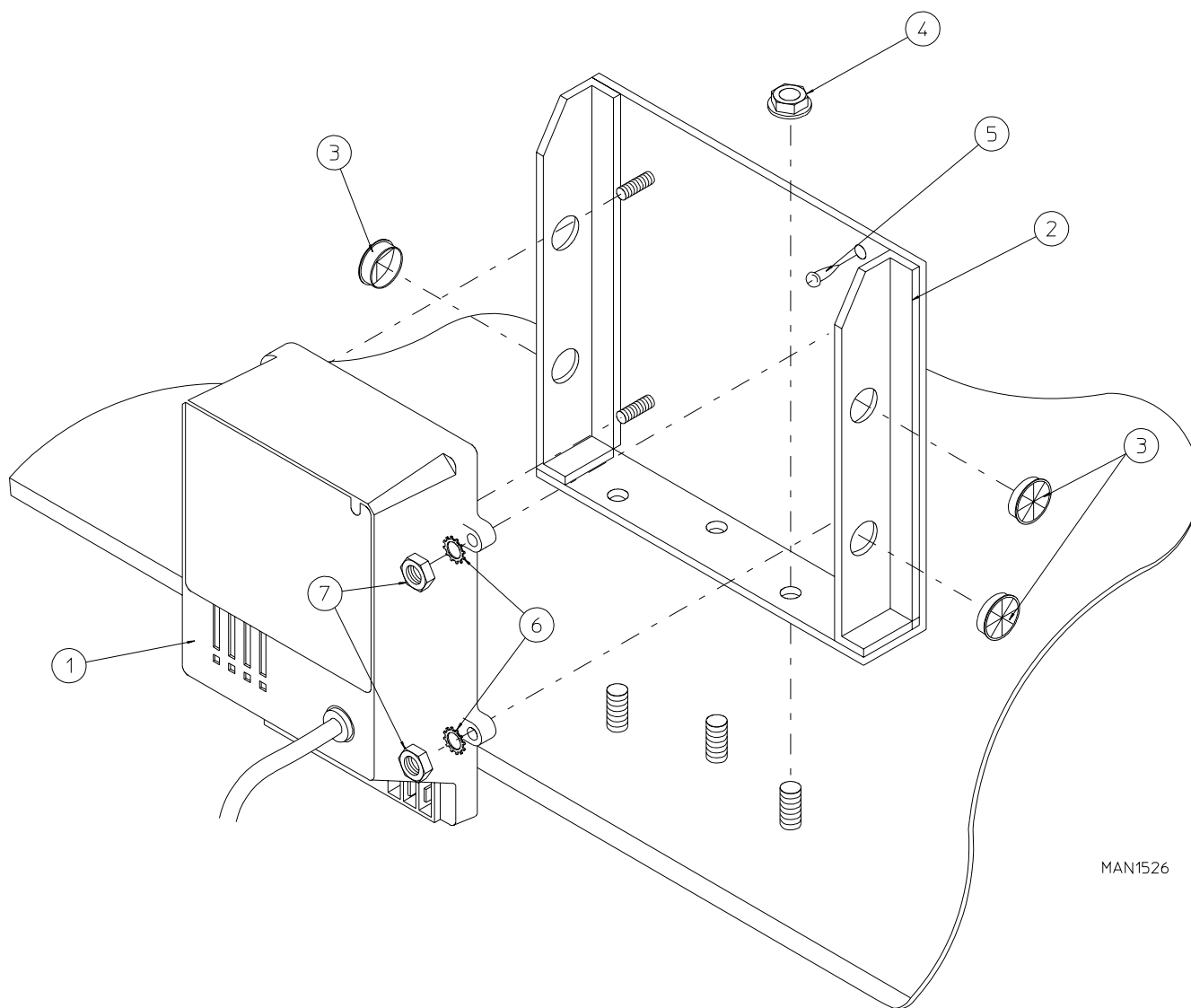

MAN1526

<u>Illus. No.</u>	<u>Part No.</u>	<u>Qty.</u>	<u>Description</u>
1	128935	1	Direct Spark Ignition with Retries (for models mfd. as of May 8, 2000)
	880815	1	ADC Direct Spark Ignition Module ONLY (50/60 Hz) (for models mfd. prior to May 8, 2000)
2	820100	1	Direct Spark Ignition Module Mount Assembly ONLY
3	121400	3	Universal Bushing
4	152014	3	1/4-20 Free Spin Wash Nut
5	150301	1	#8-18 x 7/16" Phillips Pan Head TEK Screw
6	153010	4	#6 Star Washer
7	152000	4	#6-32 Hex Nut

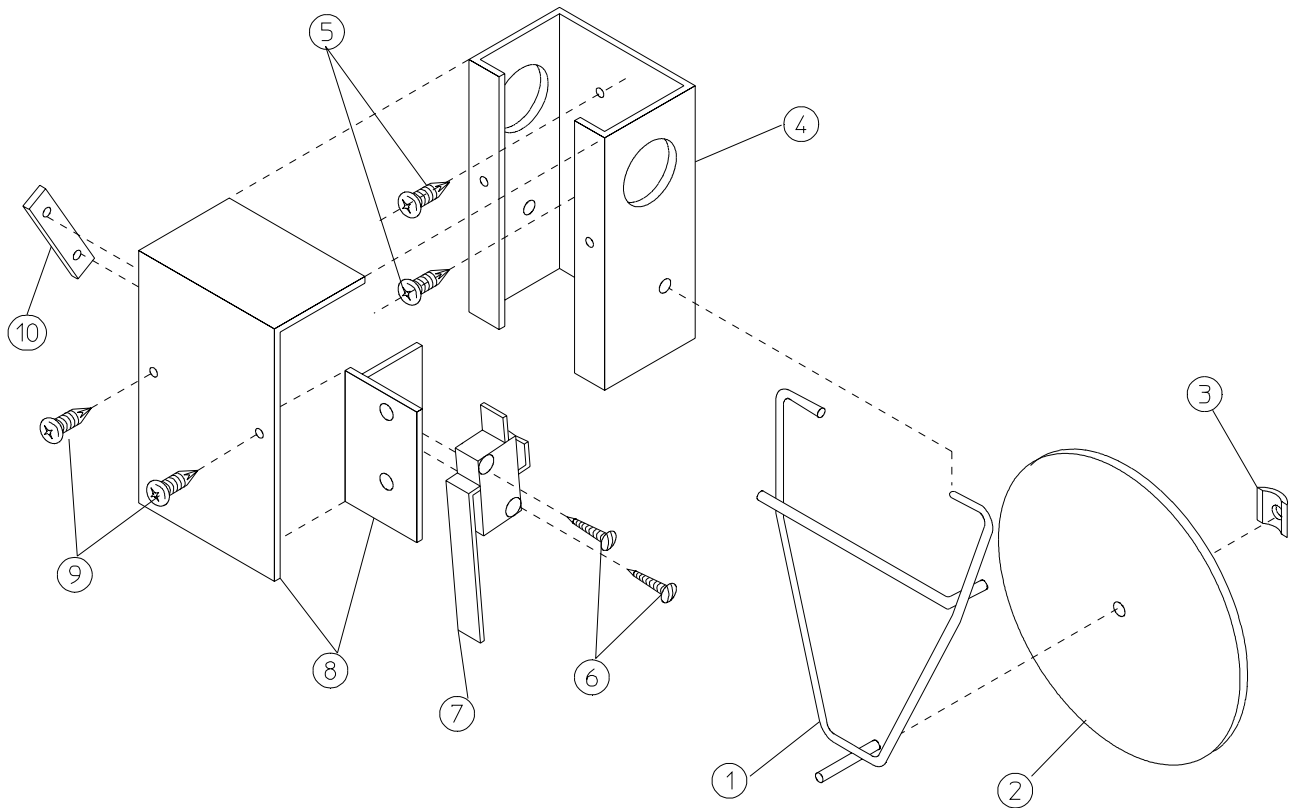

MAN0440

<u>Illus. No.</u>	<u>Part No.</u>	<u>Qty.</u>	<u>Description</u>
1	105500	1	Sail Switch Actuator Rod
2	319202	1	Sail Switch Damper (flat)
3	154002	1	1/8" Push-On Fastener
4	802800	1	Sail Switch Box with Cover and Bracket ONLY
	802801	1	Sail Switch Box Assembly Complete (includes illus. nos. 1 through 4 and 6 through 10)
5	150300	2	#10 x 1/2" Hex Washer TEK Screw
6	150303	2	#4 x 3/4" Pan Head "A" Machine Screw
7	122200	1	Sail Switch ONLY
8	802799	1	Sail Switch Box Cover and Bracket ONLY
9	150309	2	#10-16 x 1/2" Hex Head TEK Crimptite Screw
10	154004	1	Twin Speed Nut

Steam Damper Assembly

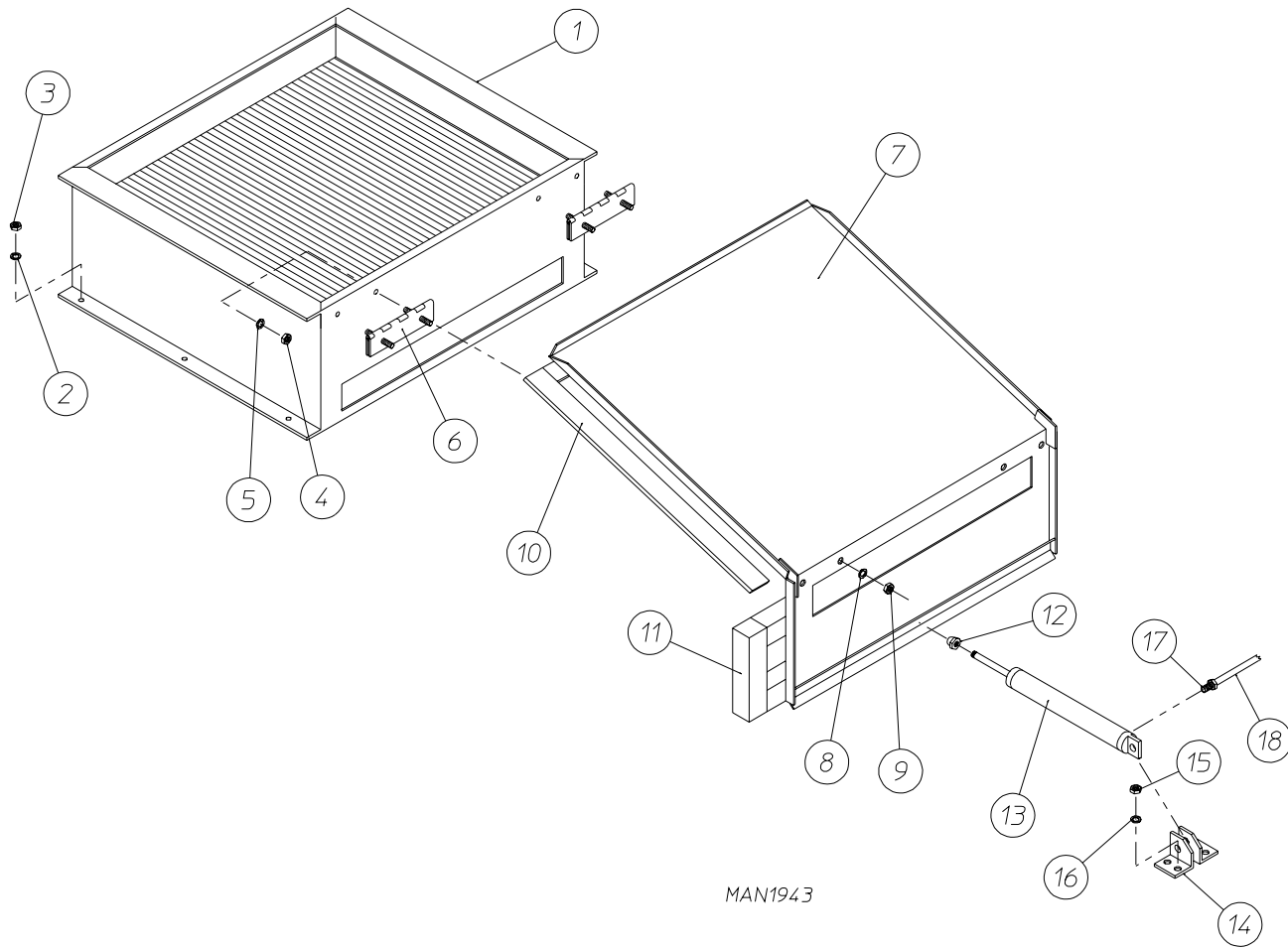

MAN1943

Illus. No.	Part No.	Qty.	Description
1	165017	1	Steam Coil ONLY
2	153002	6	5/16" Lock Washer
3	152004	6	5/16-18 Hex Nut
4	152002	4	1/4-20 Hex Nut
5	153007	4	1/4" Lock Washer
6	820321	2	Steam Damper Hinge Assembly
7	820994	1	Steam Damper Assembly (includes illus. nos. 7, 10, and 11)
8	153007	4	1/4" Lock Washer
9	152002	4	1/4-20 Hex Nut
10	115995	96	Steam Damper Gasket (sold by the inch)
11	102350	2	Steam Damper Foam (68-1/2" length)
12	151007	1	7/16-20 Stainless Steel Acorn Nut
13	100499	1	1-1/2" Bore x 3" Stroke Piston
14	100500	1	Piston Support Bracket
15	152002	4	1/4-20 Hex Nut
16	153007	4	1/4" Lock Washer
17	100472	1	1/4" x 1/8" Connector
18	143110	1	1/4" Tubing (sold by the foot)

(refer to Top Console Assembly on page 35)

Microprocessor Reversing Contactor Mounting Panel Assembly

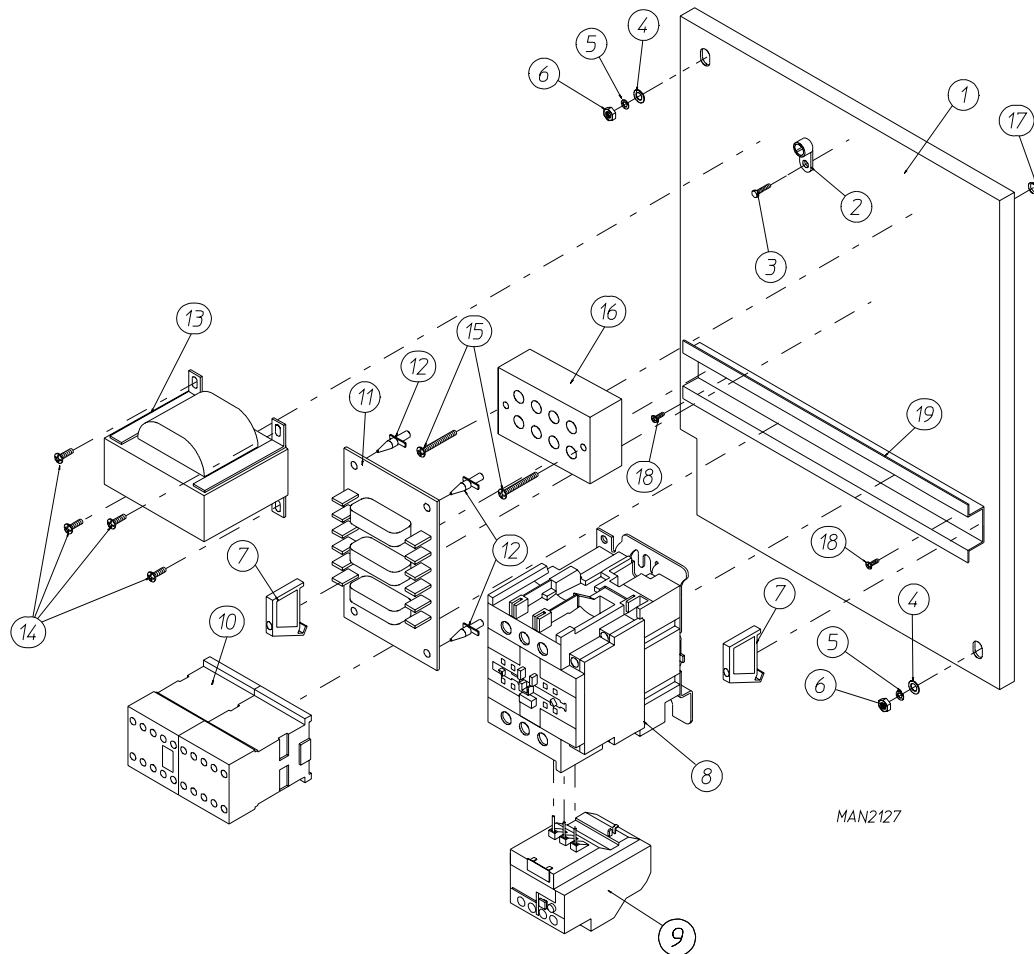

MAN2127

Illus. No.	Part No.	Qty.	Description
1	332346	1	Contactors / Relay Mounting Panel ONLY
2	121010	1	L-70 Ground Lug
3	150108	1	#8-32 x 1/2" Pan Head Machine Screw
4	153001	2	5/16" Flat Washer
5	153002	2	5/16" Lock Washer
6	152004	2	5/16-18 Hex Nut
7	120765	2	End Stop / Bracket
8	132465	1	7.5 hp (impellor / blower / fan) Contactor – 24 VAC
9	132439	1	208 Volt Blower Overload (for use on models mfd. for 208/230/240 volt electric service)
	132467	1	380 Volt Blower Overload (for use on models mfd. for 380/416/460/480/575/600 volt electric service)
10	132431	1	Reversing Contactor – 24 VAC
	132432	1	Contactors Replacement Coil – 24 VAC
11	137060	1	Arc Suppressor Board (3)
12	137013	4	Nylon Standoff
13	—	1	Step Down Transformer (refer to Step Down Transformer Application Listing on page 42)
14	150300	4	#10 x 1/2" Hex Washer TEK Screw
15	150008	2	#6-32 x 1-1/4" Slotted Round Head Machine Screw
16	120701	1	4-Position Power Distribution Block
17	151000	2	#6-32 Pal Nut
18	150309	2	#10-16 x 1/2" Hex Head TEK Crimptite Screw
19	120768	9	Din Mounting Rail (sold by the inch)

Dual Timer Reversing Relay Mounting Panel Assembly

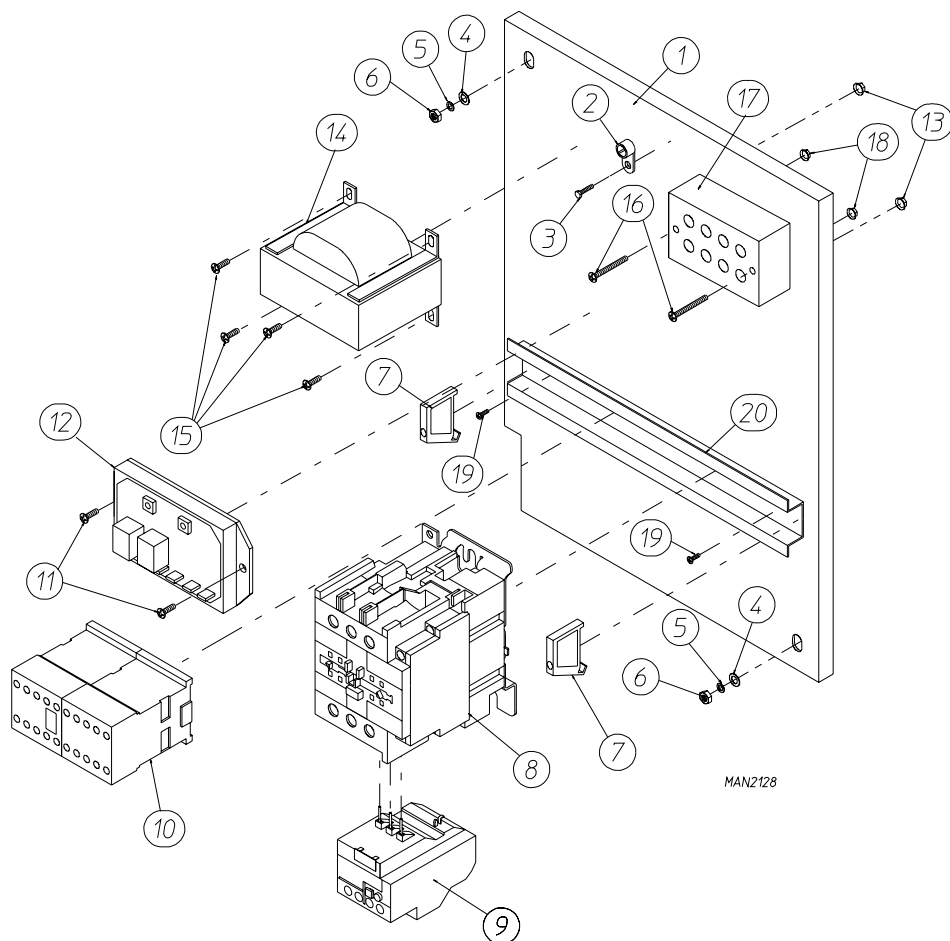

MAN2128

Illus. No.	Part No.	Qty.	Description
1	332346	1	Contactors / Relay Mounting Panel ONLY
2	121010	1	L-70 Ground Lug
3	150108	1	#8-32 x 1/2" Pan Head Machine Screw
4	153001	2	5/16" Flat Washer
5	153002	2	5/16" Lock Washer
6	152004	2	5/16-18 Hex Nut
7	120765	2	End Stop / Bracket
8	132465	1	7.5 hp (impellor / blower / fan) Contactor – 24 VAC
9	132439	1	Blower Overload (for use on models mfd. for 208/230/240 volt electric service)
	132467	1	Blower Overload (for use on models mfd. for 308/416/460/480/575/600 volt electric service)
10	132431	1	Reversing Contactor – 24 VAC
	132432	1	Contactors Replacement Coil – 24 VAC
11	150100	2	#8-32 x 1/2" Phillips Round Head Screw
12	132198	1	Reversing Timer ONLY (50/60 Hz) – 24 VAC
13	151001	2	#8-32 Pal Nut
14	—	1	Step Down Transformer (refer to Step Down Transformer Application Listing on page 42)
15	150300	4	#10 x 1/2" Hex Washer TEK Screw
16	150008	2	#6-32 x 1-1/4" Slotted Round Head Machine Screw
17	120701	1	4-Position Power Distribution Block
18	151000	2	#6-32 Pal Nut
19	150309	2	#10-16 x 1/2" Hex Head TEK Crimpite Screw
20	120768	9	Din Mounting Rail (sold by the inch)

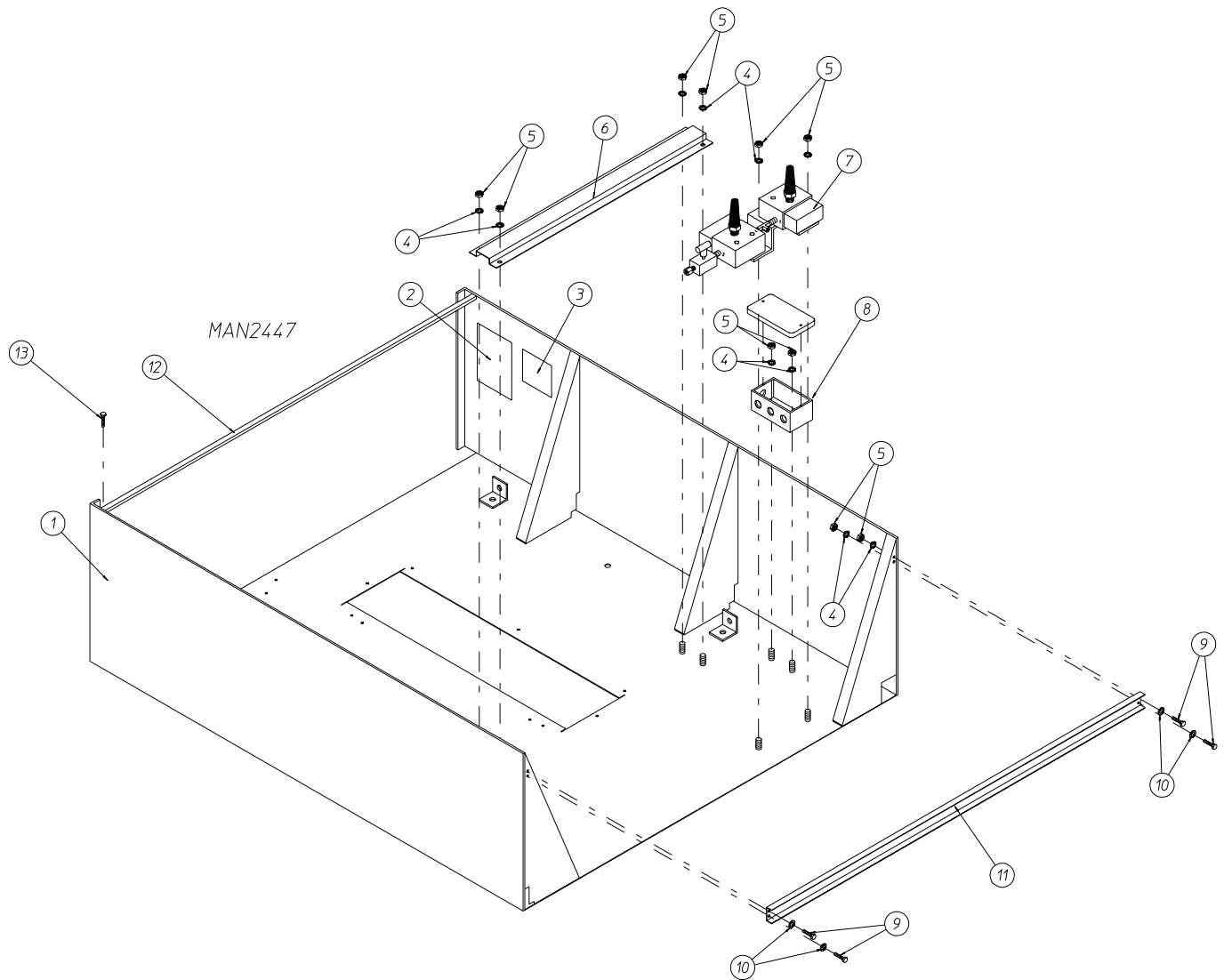

Illus. No.	Part No.	Qty.	Description
1*	821085	1	Top Console Assembly ONLY (for gas models Only)
	821086	1	Top Console Assembly ONLY (for steam models Only)
2	112534	1	Phase 5 Non-Coin Program Location Summary Label (for microprocessor models Only)
3	—	1	Dryer Data Label (not for resale by ADC)
4	153007	12	1/4" Lock Washer
5	152005	12	1/4-20 Hex Nut
6	332323	1	32" Wire Channel
7	821105	1	Pneumatic Valve Assembly ONLY (for gas models Only) (refer to Pneumatic Valve Assembly on page 36)
	821104	1	Pneumatic Valve Assembly ONLY (for steam models Only) (refer to Pneumatic Valve Assembly on page 37)
8	121104	1	2" x 4" Junction Box ONLY
	121105	1	Junction Box Cover ONLY
9	150615	4	1/4-20 x 3/4" Bolt
10	153018	4	1/4" Flat Washer
11	332132*	1	Console Gusset Brace
12	332186	1	Control Door Hinge Channel
13	150300	2	#10 x 1/2" Hex Washer TEK Screw

* Specify color when ordering.

Pneumatic Valve Assembly

For Gas Models Only

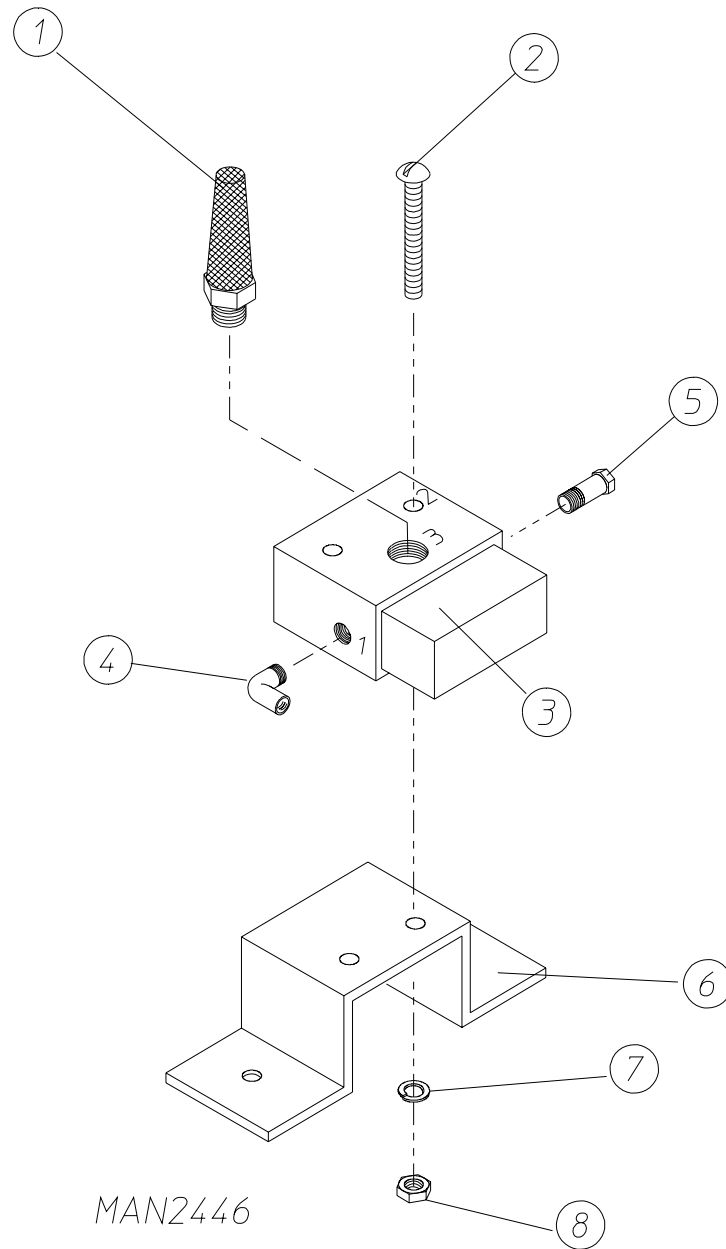

Illus. No.	Part No.	Qty.	Description
1	100520	1	1/8" N.P.T. Silencer (muffler)
2	150002	1	#6-32 x 1" Phillips Round Head Machine Screw
3	100498	1	3-Way Micro Valve ONLY – 24 VAC
	821105	1	Pneumatic Valve Assembly Complete for Gas Models ONLY (includes illus. nos. 1 through 8)
4	143268	1	1/8" Street Elbow
5	100472	1	1/4" x 1/8" Connector
6	330987	1	Micro Valve Support Bracket ONLY
7	153010	1	#6 Star Washer
8	152000	1	#6-32 Hex Nut

Pneumatic Valve Assembly

For Steam Models Only

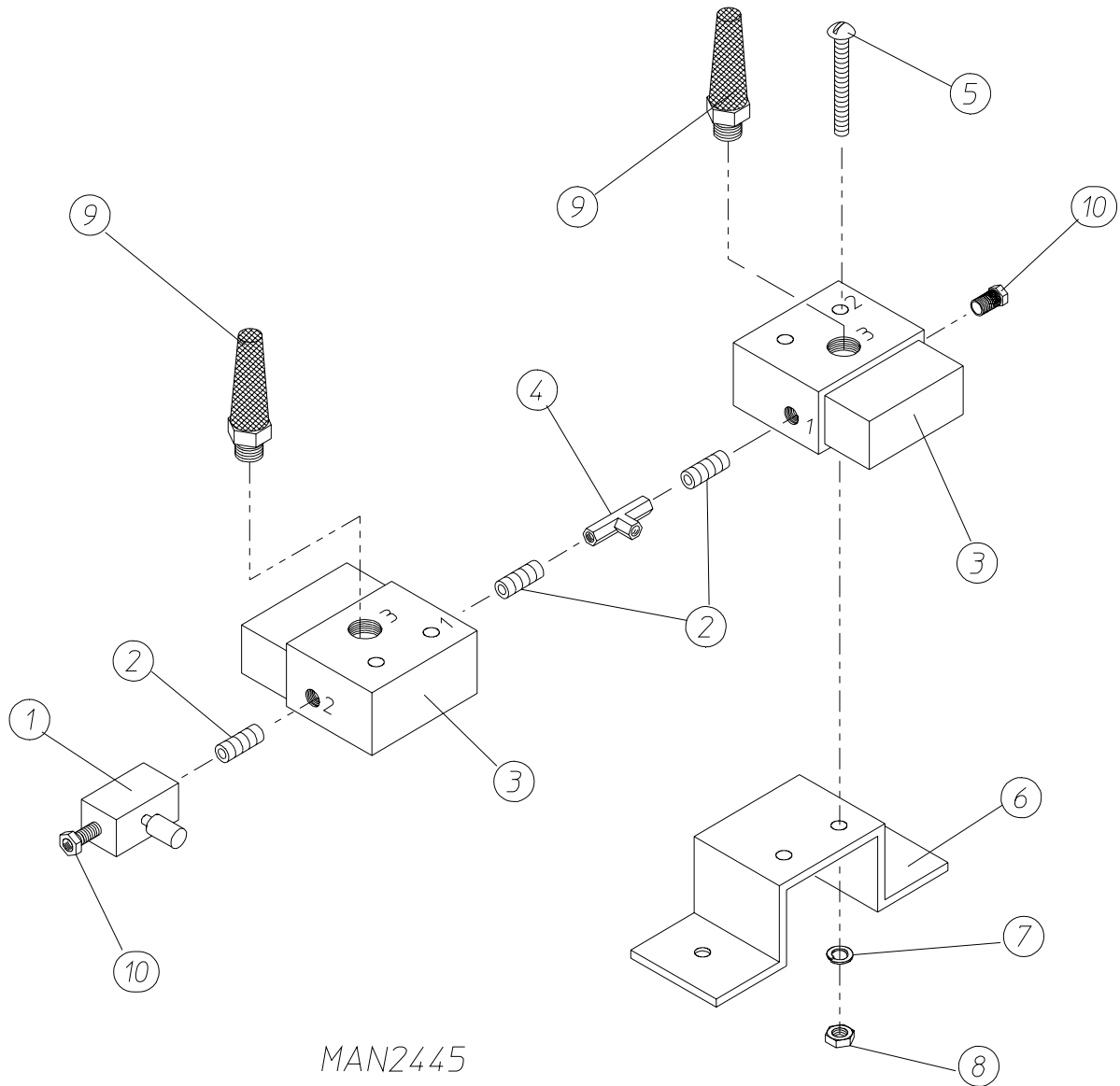

MAN2445

Illus. No.	Part No.	Qty.	Description
1	100496	1	1/8" Needle Valve
2	143238	3	1/8" Close Nipple
3	100498	2	3-Way Micro Valve ONLY – 24 VAC
	821104	1	Pneumatic Valve Assembly Complete for Steam Models ONLY (includes illus. nos. 1 through 8)
4	143223	1	1/8" F.P.T. Brass Tee
5	150002	1	#6-32 x 1" Phillips Round Head Machine Screw
6	330987	1	Micro Valve Support Bracket ONLY
7	153010	2	#6 Star Washer
8	152000	2	#6-32 Hex Nut
9	100520	2	1/8" N.P.T. Silencer (muffler)
10	100472	2	1/4" x 1/8" Connector

Air Jet Assembly

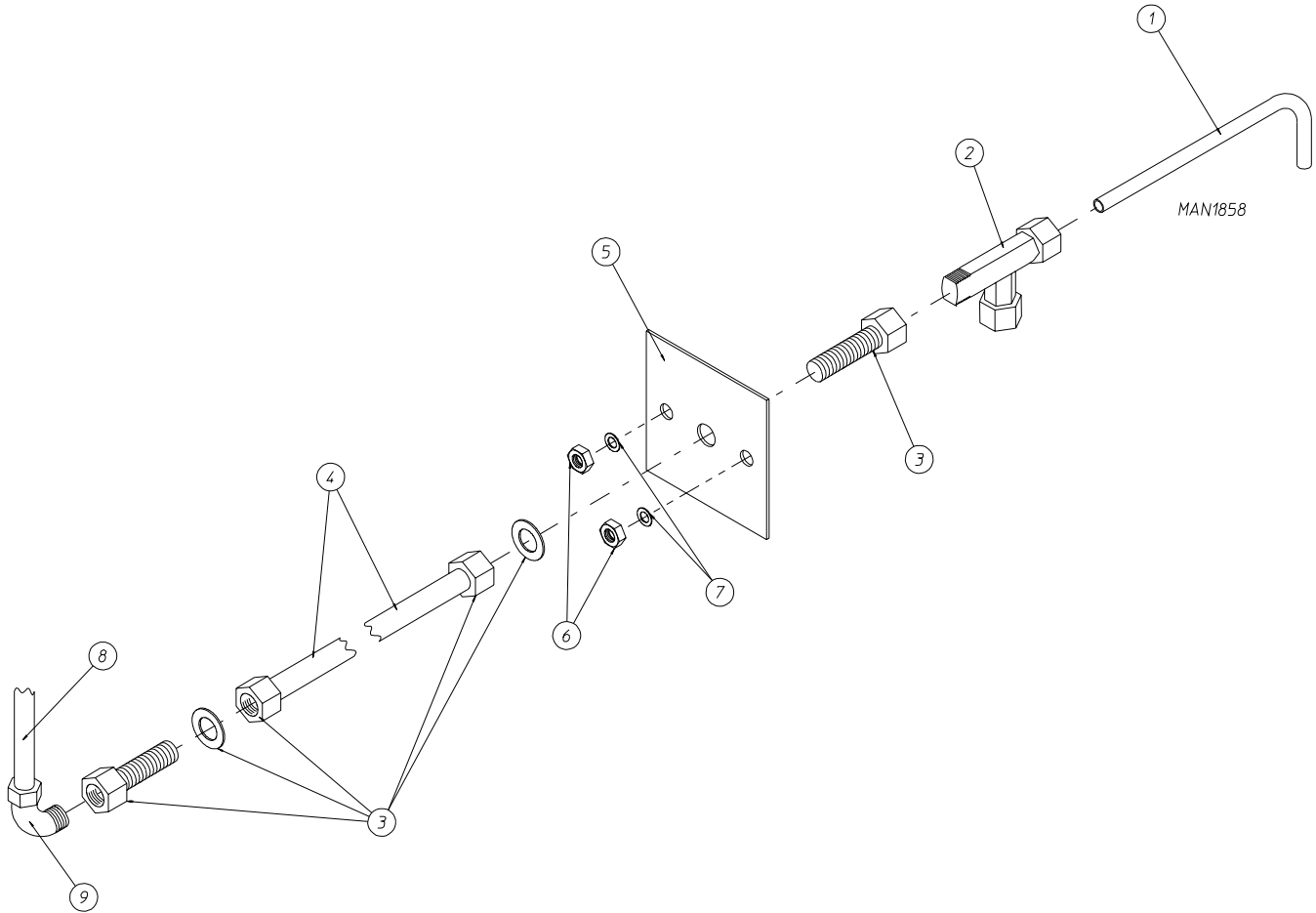

Illus. No.	Part No.	Qty.	Description
1	332700	1	Air Jet Tube ONLY
2	143287	1	1/4" Compression x 1/8" M.P.T. Male Run Tee
3	143259	2	1/4" Compression x 1/8" F.P.T. Bulkhead Fitting
4	143100	3	1/4" Aluminum Tube (sold by the foot)
5	821081	1	Air Jet Mounting Plate ONLY (includes illus. nos. 1 through 9)
	332531	1	Air Jet Mounting Plate ONLY
6	152002	2	1/4-20 Hex Nut
7	153007	2	1/4" Lock Washer
8	143110	5	1/4" Poly Flo Tubing (sold by the foot)
9	143149	1	1/4" x 1/8" M.P.T. 90° Elbow

Back Guard Assemblies

For Models Mfd. as of June 16, 1995

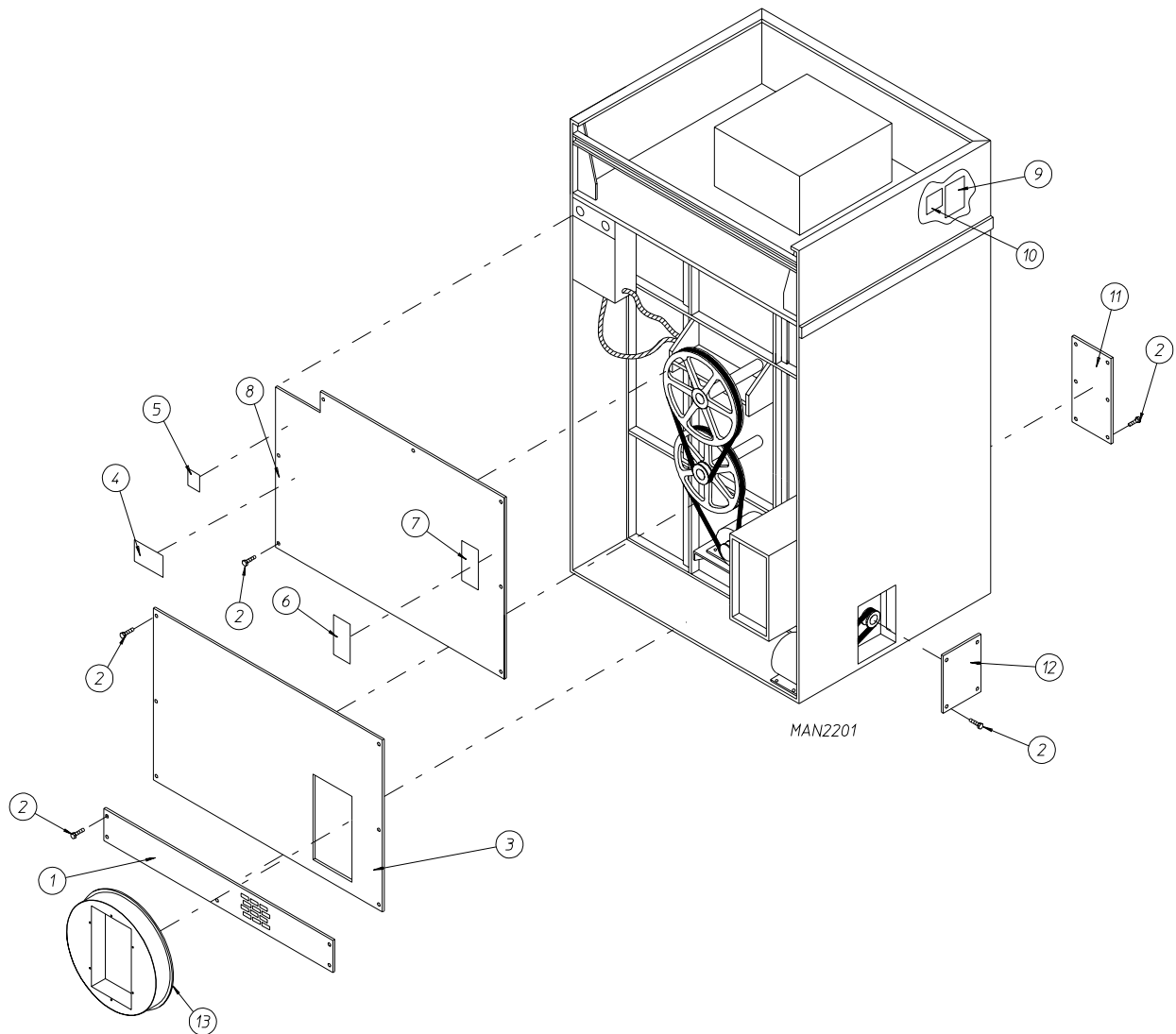

<u>Illus. No.</u>	<u>Part No.</u>	<u>Qty.</u>	<u>Description</u>
1	332328	1	Bottom Back Guard ONLY
2	150301	28	#8-18 x 7/16" Phillips Pan Head TEK Screw
3	821096	1	Middle Back Guard ONLY
4	112014	1	High Voltage Label ONLY
5	112017	1	"ADC Name, Address, Telephone Number" Label
6	112230	1	"Installation Instructions" Label
7	112519	1	"Routine Maintenance Schedule" Label
8	821095	1	Top Back Guard ONLY
9	112534	1	"Phase 5 Non-Coin Program Location Summary" Label (for microprocessor models Only)
10	—	1	Dryer Data Label (not for resale by ADC)
11*	332295	1	Blower Housing Front Access Panel
12*	332309	1	Side Access Panel
13	821092	1	Square Duct to Round Duct Transition Piece Assembly
—	117505	**	Aluminum Duct Tape

* Specify color when ordering.

** As required.

Back Guard Assemblies

For Models Mfd. prior to June 16, 1995

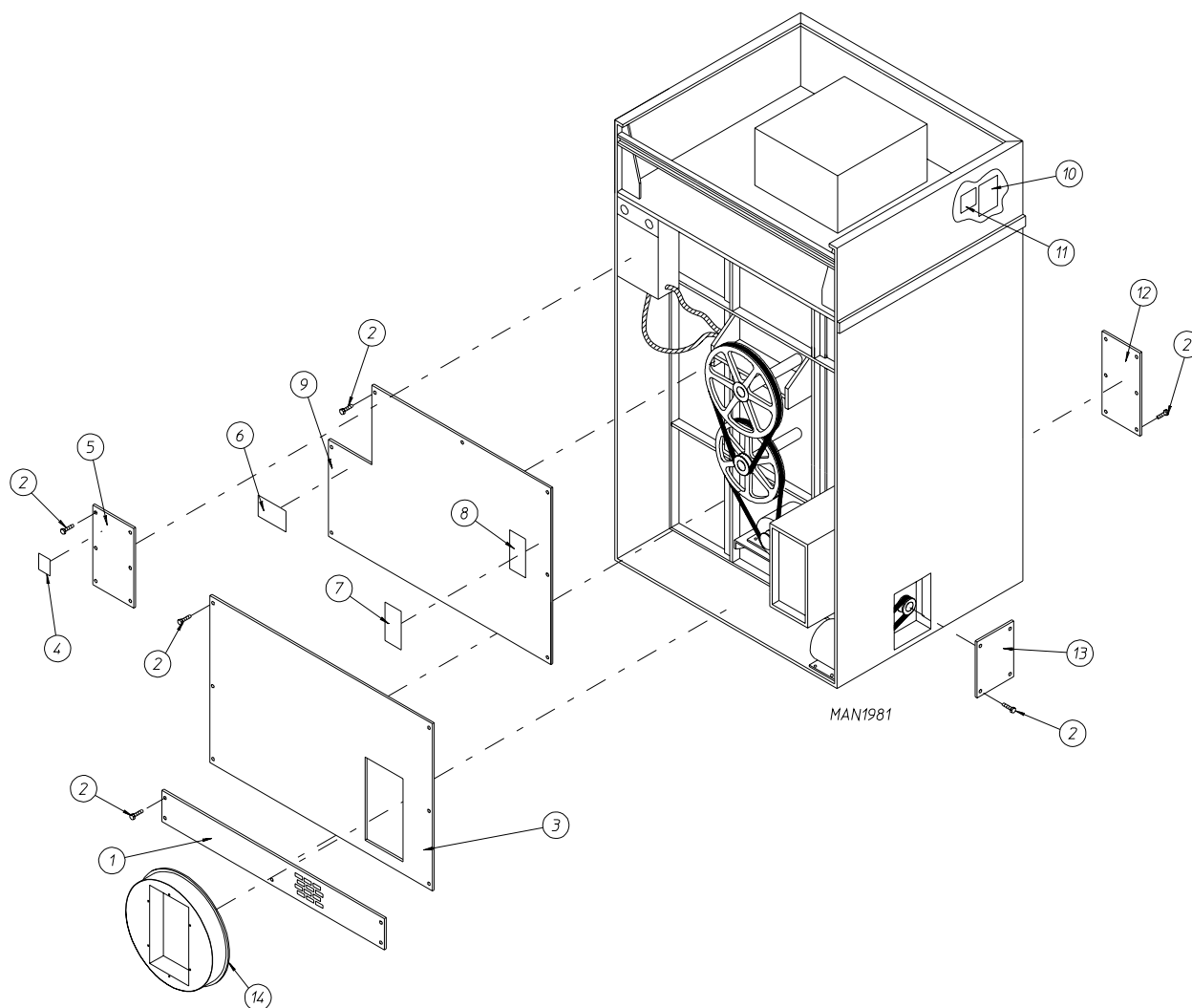

Illus. No.	Part No.	Qty.	Description
1	332328	1	Bottom Back Guard ONLY
2	150301	34	#8-18 x 7/16" Phillips Pan Head TEK Screw
3	821096	1	Middle Back Guard ONLY
4	112014	1	High Voltage Label ONLY
5	332347	1	Large Reversing Relay Cover
6	112017	1	"ADC Name, Address, Telephone Number" Label
7	112230	1	"Installation Instructions" Label
8	112519	1	"Routine Maintenance Schedule" Label
9	821095	1	Top Back Guard ONLY
10	112534	1	"Phase 5 Non-Coin Program Location Summary" Label (for microprocessor models Only)
11	—	1	Dryer Data Label (not for resale by ADC)
12*	332295	1	Blower Housing Front Access Panel
13*	332309	1	Side Access Panel
14	821092	1	Square Duct to Round Duct Transition Piece Assembly
—	117505	**	Aluminum Duct Tape

* Specify color when ordering.

** As required.

DSI Burner Orifice Specification*				
Qty.	Natural Gas		L.P. Gas	
	D.M.S.	Part No.	D.M.S.	Part No.
4	#2	140839	#29	140820

* Consult factory for elevations over 2,000 feet.

DSI Burner Assembly Specifications		
Btu/H Rating	Natural Gas Part No.	L.P. Gas Part No.
550,000	821106	821107
<p>NOTES:</p> <ol style="list-style-type: none"> 1. Burner assemblies do not include burner orifices. They must be ordered. 2. When ordering burner assembly specify the model number and serial number of the dryer. 		

DSI L.P. Kit Specification*
Kit Part No. 880978

* Consult factory for elevations over 2,000 feet.

Step Down Transformer Application Listing

NOTE: For voltages of 380 or above.

Step Down Transformer Application Listing (Reversing Relay Box)				
Heat	Voltage	Wire Service	Transformer Part Number	
			Microprocessor Models	Timer Models
Gas/ Steam	380	3 or 4	132059	132059
	416	3 or 4	132062	132062
	440	3 or 4	132056	132056
	460 / 480	3 or 4	132053	132053
	575	3	132050	132050

<u>Part No.</u>	<u>Description</u>
114006	“WARNING – Fire Hazards” Label
112098	“Check Rotation” Label
112288	“CAUTION – Lint Compartment” Label
114001	“CAUTION – Exhaust Lint Screen” Label
120102	3/8” Straight (BX) Connector
120111	1/2” Liquidtite 45° Connector
120400	3/8” Red Jacket (BX) Insulator
120500	3/8” Jiffy Clip (BX retainer clip)
120600	3/8” Greenfield (BX)
120800	1/4” In-Line Connector
120802	Red Butt Connector
120902	#74B Wire Nut
120903	Crimp-On Wire Nut
120904	Red Wire Nut
121014	1/4” Insulated (female) Terminal
121499	5-1/2” Harness Tie
121500	8” Harness Tie
122804	15” Manometer (water column test gauge)
404500	Almond Brush-In-Cap Bottle Touch-Up Paint
404502	White Brush-In-Cap Bottle Touch-Up Paint
404506	Beige Brush-In-Cap Bottle Touch-Up Paint
404507	Cornflower Blue Brush-In-Cap Bottle Touch-Up Paint
880200	Electrical Terminal (assortment) Kit

