



AD-170SE
Parts Manual
Phase 7
Microprocessor Models

American Dryer Corporation

88 Currant Road, Fall River MA 02720-4781 USA
Telephone: +1 (269) 923-3000 / Fax: +1 (508) 678-9447
e-mail: mdl-service@whirlpool.com / www.adclaundry.com

Retain This Manual In A Safe Place For Future Reference

American Dryer Corporation products embody advanced concepts in engineering, design, and safety. If this product is properly maintained, it will provide many years of safe, efficient, and trouble free operation.

ONLY qualified technicians should service this equipment.

OBSERVE ALL SAFETY PRECAUTIONS displayed on the equipment or specified in the installation manual included with the dryer.

The following “**FOR YOUR SAFETY CAUTION**” must be posted near the dryer in a prominent location.

FOR YOUR SAFETY

Do not store or use gasoline or other flammable vapors and liquids in the vicinity of this or any other appliance.

POUR VOTRE SÉCURITÉ

Ne pas entreposer ni utiliser d'essence ni d'autres vapeurs ou liquides inflammables à proximité de cet appareil ou de tout autre appareil.

We have tried to make this manual as complete as possible and hope you will find it useful. ADC reserves the right to make changes from time to time, without notice or obligation, in prices, specifications, colors, and material, and to change or discontinue models.

Important

For your convenience, log the following information:

DATE OF PURCHASE _____ **MODEL NO.** AD-170SE

RESELLER'S NAME _____

Serial Number(s) _____

Replacement parts can be obtained from your reseller or the ADC factory. When ordering replacement parts from the factory, you can FAX your order to ADC at +1 (508) 678-9447 or telephone your order directly to the ADC Parts Department at +1 (269) 923-3000. Please specify the dryer model number and serial number in addition to the description and part number, so that your order is processed accurately and promptly.

The illustrations on the following pages may not depict your particular dryer exactly. The illustrations are a composite of the various dryer models. Be sure to check the descriptions of the parts thoroughly before ordering.

“IMPORTANT NOTE TO PURCHASER”

Information must be obtained from your local gas supplier on the instructions to be followed if the user smells gas. These instructions must be posted in a prominent location near the dryer.

Table of Contents

Control Door Assembly	4
Phase 7 Microprocessor Control Panel Assembly	5
Dual Timer Control Panel for Models Mfd. as of October 6, 2011	6
Dual Timer “Tap Touch” Controls for Models Mfd. prior to October 6, 2011	7
Main Door Assembly for Models Mfd. as of September 10, 2005	8
Front Panel for Models Mfd. as of September 10, 2005	9
Front Panel / Main Door Assemblies for Models Mfd. prior to September 10, 2005	10
Lint Door Assembly	12
Lint Drawer / Lint Drawer Switch Box Assemblies	13
Microprocessor Temperature Sensor Bracket Assembly	14
Tumbler / Support Assemblies	15
Tumbler Bearing Mount Assembly	16
Idler Bearing Mount Assembly	17
Direct Spark Ignition Burner Assembly	18
Totally Enclosed, Fan-Cooled Tumbler Motor Mount Assembly	20
Blower Motor Mount Assembly	21
Fan Shaft Mount Assembly for Gas Models Only	22
Fan Shaft Mount Assembly for Steam Models Only	23
Gas / Steam 208V / 240V Dual Timer	24
Electric Models 208V / 240V Dual Timer	25
Microprocessor Reversing Contactor Mounting Panel Assembly for 208-240V Transformers	26
Microprocessor Reversing Contactor Mounting Panel Assembly for 380-416V Transformers	28
Microprocessor Reversing Contactor Mounting Panel Assembly for 460-480V Transformers	30
Sail Switch Assembly	32
Steam Damper Assembly	33
Top Console Assembly	34
Air Jet Assembly	35
Pneumatic Valve Assembly for Gas Models Only	36
Pneumatic Valve Assembly for Steam Models Only	37
S.A.F.E. System Solenoid Assembly for Models Mfd. as of September 23, 2004	38
S.A.F.E. Solenoid Assembly for Models Mfd. between December 3, 2003 - September 13, 2004	39
S.A.F.E. Solenoid Assembly for Models Mfd. prior to December 3, 2003	40
S.A.F.E. Temperature Probe Assembly	41
Back Guard Assemblies	42
Direct Spark Ignition Burner Assembly Specifications	43
Step Down Transformer Application Listing	44
Additional Parts Available	45

Control Door Assembly

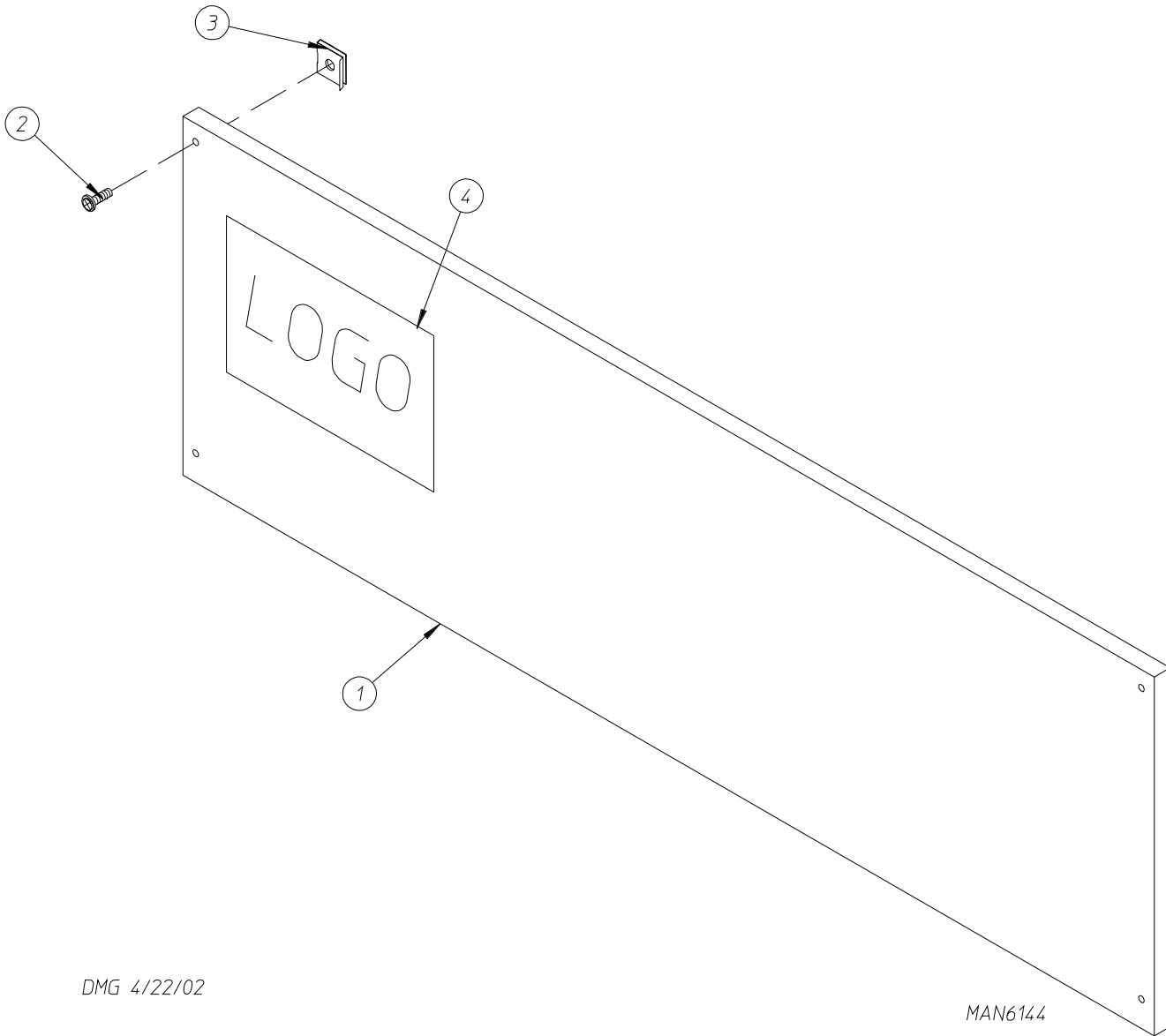

DMG 4/22/02

MAN6144

Illus. No.	Part No.	Qty.	Description
1*	883860	1	Control Door (for gas models Only)
	883861	1	Short Control Door (for steam models Only)
2	154011	4	#10-32 Multi-Thread U-Nut
3	150321	4	#10-32 x 1/2" Phillips Head Machine Screw
4	—	—	Contact ADC

* Specify color when ordering.

Phase 7 Microprocessor Control Panel Assembly

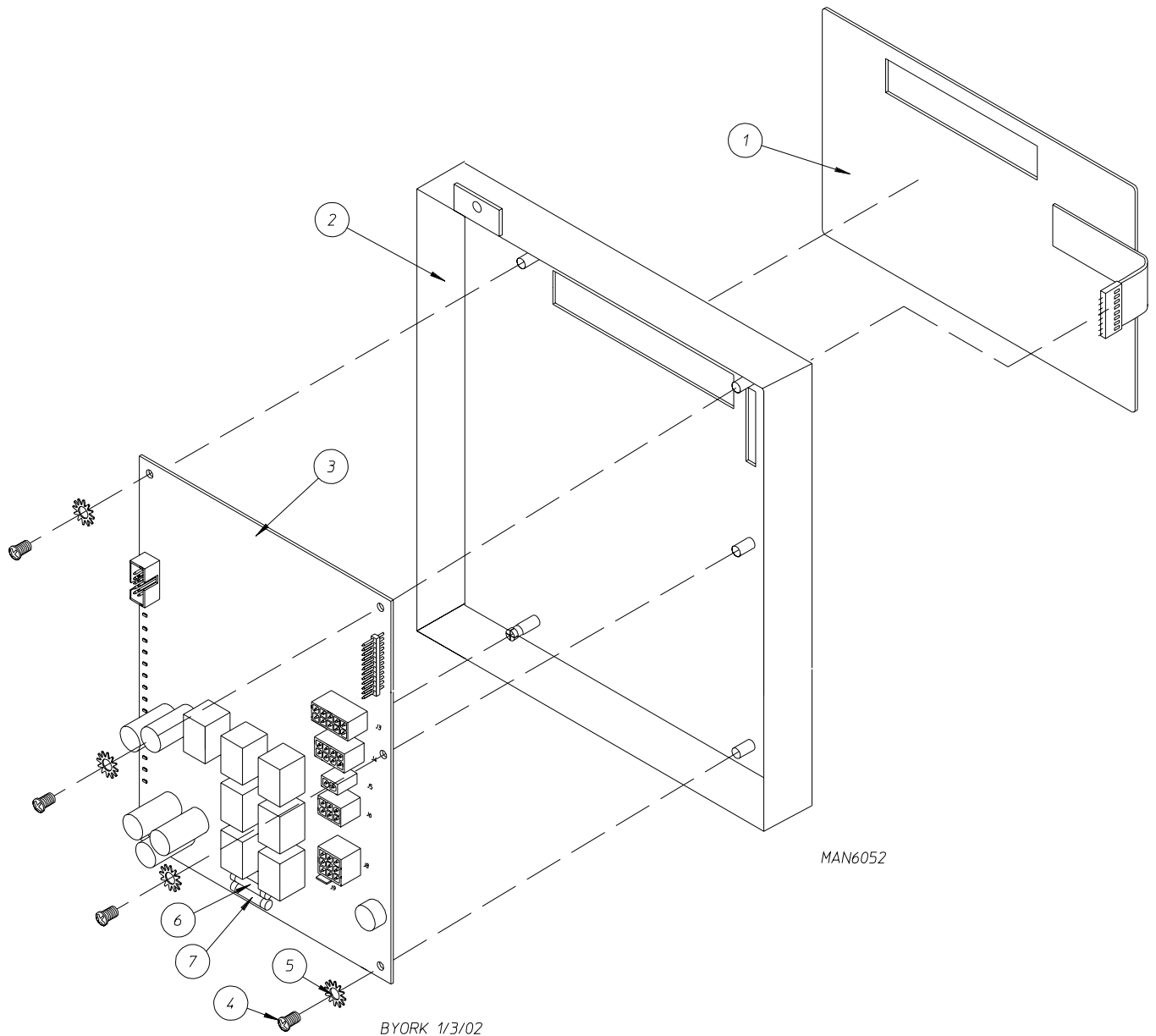

Illus. No.	Part No.	Qty.	Description
1	112577	1	Phase 7.2 Non-Coin and Label Keypad
2	850980	1	Phase 7 Computer Door
3	887003	1	Phase 7 Non-Coin Reversing Microprocessor Controller with Fire Suppression (for models mfd. as of December 3, 2003)
	887000	1	Phase 7 Non-Coin Reversing Microprocessor Controller with Fire Suppression (for models mfd. prior to December 3, 2003)
	887024	1	Phase 7 Non-Coin Reversing Microprocessor Controller without Fire Suppression
4	150005	4	#6-32 x 1/4" Phillips Round Head Screw
5	153010	4	#6 Star Washer
6	136016	1	5-Amp Fuse
7	136097	1	500 mA Fuse

Dual Timer Control Panel

For Models Mfd. as of October 6, 2011

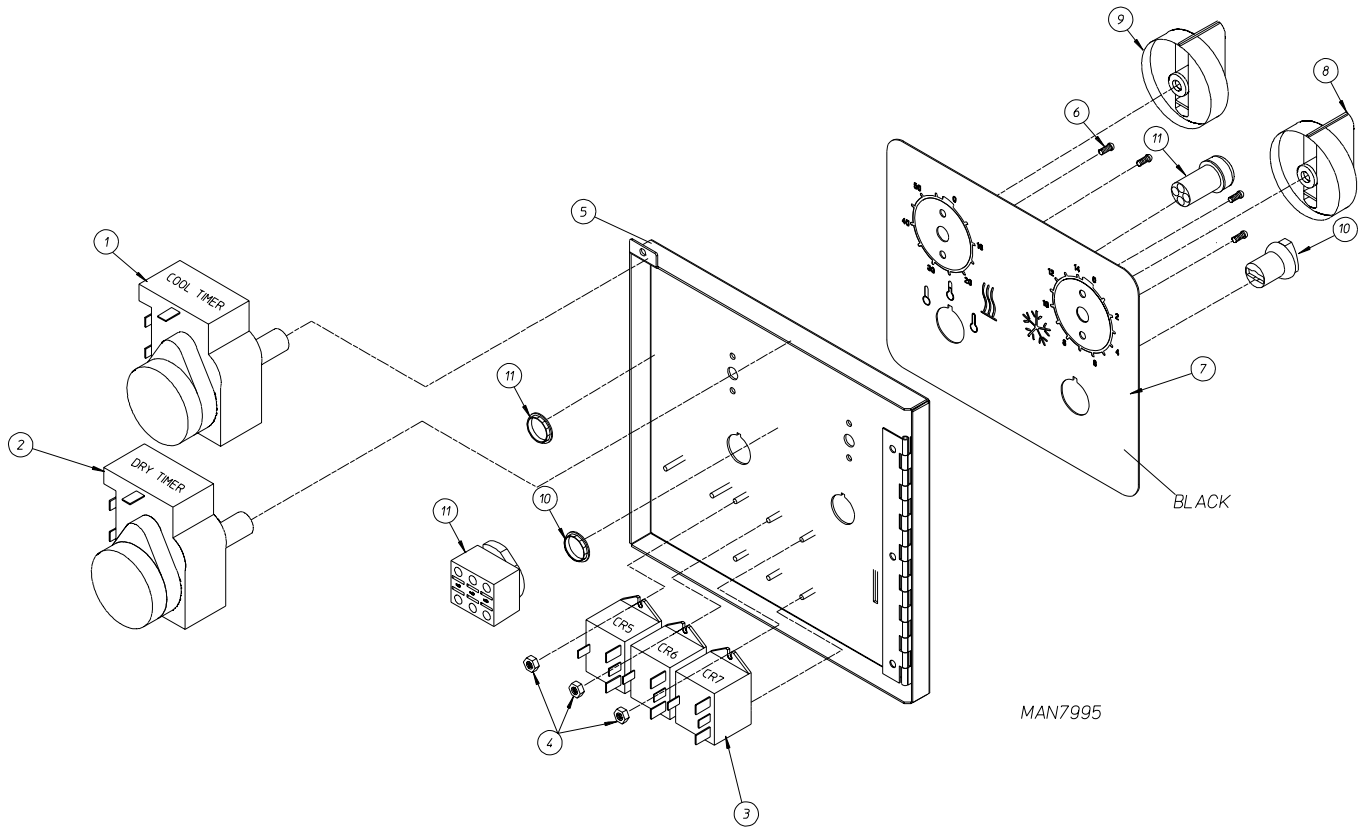

<u>Illus. No.</u>	<u>Part No.</u>	<u>Qty.</u>	<u>Description</u>
1	802837	1	15 Minute Timer with Terminals
2	802838	1	60 Minute Timer with Terminals
3	131406	3	Relay SPDT 24V
4	152013	7	#6-32 Hex Nut
5	828262	1	Dual Timer Panel Clinch
6	150110	4	#8-32 x 1/4" Phillips Machine Screw
7	112558	1	Dual Timer Cover Plate
8	124104	1	Pure Touch Know with Red Pointer
9	124105	1	Pure Touch Know with Blue Pointer
10	100299	1	Green Lighted Push Button with Normal Open
11	123549	1	3-Position Selector Switch

Dual Timer "Tap Touch" Controls

For Models Mfd. prior to October 6, 2011

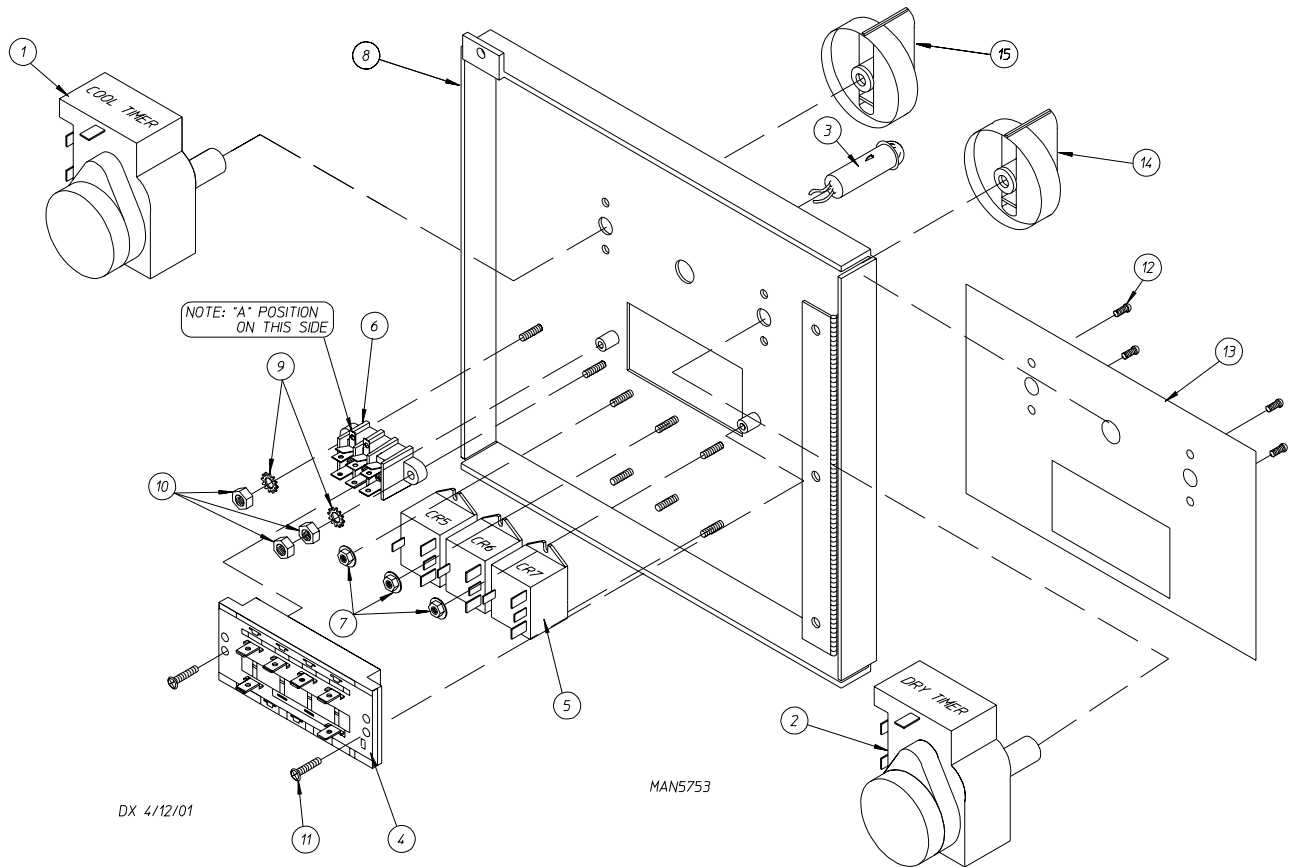

Illus. No.	Part No.	Qty.	Description
1	824298	1	15 Minute Timer – 24 VAC
2	824299	1	60 Minute Timer – 24 VAC
3	824175	1	Red Pilot Light – 24 VAC
4	122301	1	"Tap Touch" Switch
5	131932	3	24 VAC Relay
6	120708	1	3, Terminal Closed Block
7	151000	6	#6-32 Pan Nut
8	824297	1	Dual Timer Panel Complete (includes illus. nos. 1 through 15)
	824068	–	Dual Timer Panel Only
9	153010	2	#6 Star Washer
10	152000	3	#6-32 Hex Nut
11	150207	2	#10-24 x 1/2" Phillips Pan Head Machine Screw
12	150110	4	#8-32 x 1/4" Phillips Round Head Machine Screw
13	112563	1	Dual Timer Panel Overlay
14	124104	1	Pure Touch Knob with Red Pointer
15	124105	1	Pure Touch Knob with Blue Pointer

Main Door Assembly

For Models Mfd. as of September 10, 2005

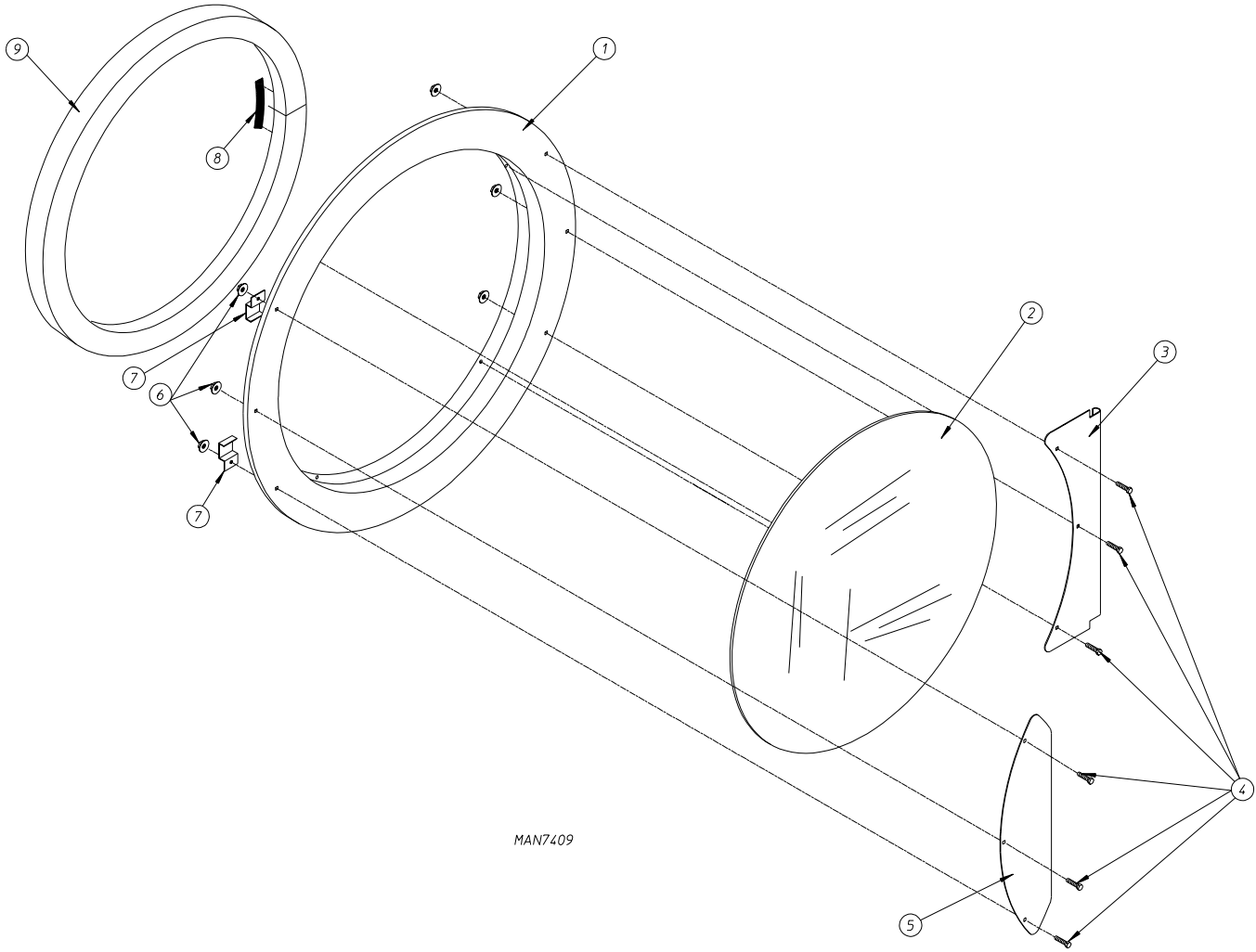

MAN7409

<u>Illus. No.</u>	<u>Part No.</u>	<u>Qty.</u>	<u>Description</u>
1	801600	1	37-1/4" Round Door
2	102221	1	30" Door Glass
3	835128	1	Large Main Door Hinge
4	150683	6	1/4-20 x 5/8" Black Carriage Bolt
5	884367	1	Large Main Door Handle
6	152014	6	1/4-20 Free Spin Wash Nut
7	185522	2	37-1/4" Main Door Magnet Bracket
8	110006	2	1/2" Black Strapping Tape
9	102357	1	Extruded Steel Door Gasket

For Models Mfd. as of September 10, 2005

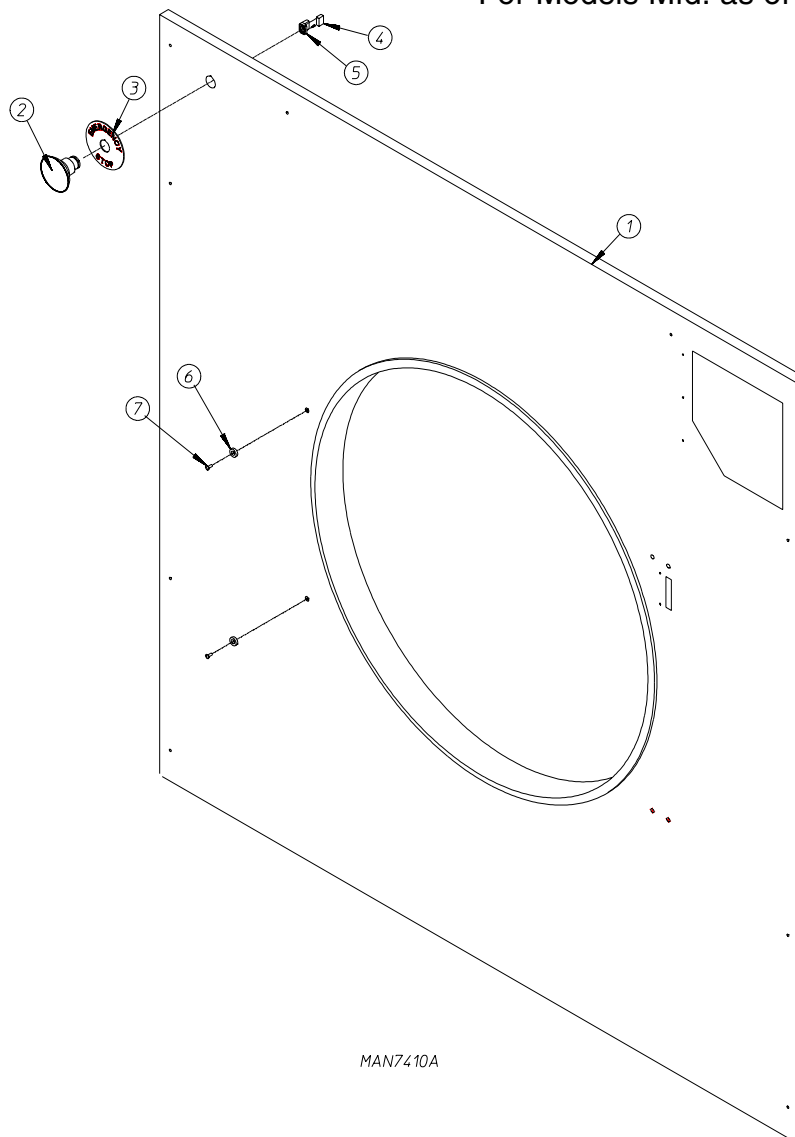

MAN7410A

Illus. No.	Part No.	Qty.	Description
1	801633*	1	Magnet Front Panel
	802041*	1	Magnet Front Panel with E-Stop
2	123583	1	One Piece Emergency Stop Switch Assembly (for models mfd. as of August 5, 2011)
	123553**	1	Large Emergency Stop Mushroom Head Switch (for models mfd. prior to August 5, 2011)
3	112599	1	Emergency Stop Nameplate (for models mfd. as of August 5, 2011)
	123506	1	Emergency Stop Nameplate (for models mfd. prior to August 5, 2011)
4	123555**	1	Normally Open Contact Block (for models mfd. prior to August 5, 2011)
5	123554**	1	Normally Closed Contact Block with Base (for models mfd. prior to August 5, 2011)
6	102004	2	Compact Door Magnet
7	152223	2	#10-32 x 1/2" FH T-20 TORX® Machine Screw

* Specify color when ordering.

** Models mfd. prior to February 20, 2007 will require entire E-Stop assembly kit (P/N 887179).

Front Panel / Main Door Assemblies

For Models Mfd. prior to September 10, 2005

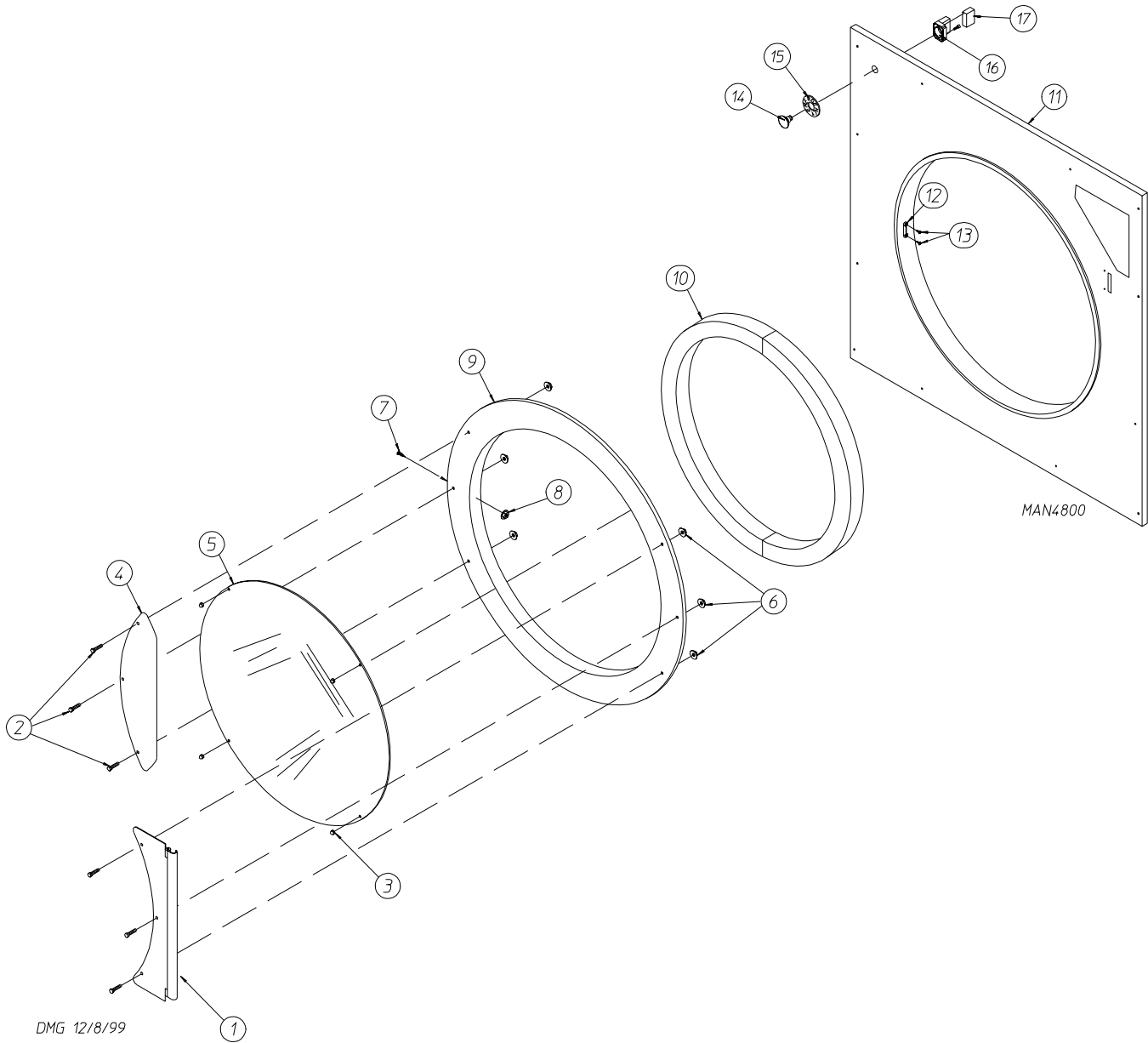

Front Panel / Main Door Assemblies

For Models Mfd. prior to September 10, 2005

<u>Illus. No.</u>	<u>Part No.</u>	<u>Qty.</u>	<u>Description</u>
1	881685	1	White Main Door Hinge
	882296	1	Coral Wrinkle Blue Main Door Hinge
2	881740	6	1/4-20 x 5/8" White Carriage Bolt
	881739	6	1/4-20 x 5/8" Coral Wrinkle Blue Carriage Bolt
3	151012	1	#10-32 White Acorn Nut
4	881688	1	White Main Door Handle
	881737	1	Coral Wrinkle Blue Main Door Handle
5	102221	1	30" Door Glass (for models mfd. as of November 6, 2003)
	102214	1	30" Door Glass (for models mfd. prior to November 6, 2003)
	170730	1	Door Glass Adhesive (10.3 oz. cartridge)
6	881806	6	1/4-20 White Free Spin Wash Nut
	882293	6	1/4-20 Coral Wrinkle Blue Free Spin Wash Nut
7	150125	1	Main Door Latch Screw
8	151010	1	#10-32 Acorn Nut
9	881689	1	White Main Door Assembly Complete (includes illus. nos. 1 through 10)
	881761	1	Coral Wrinkle Blue Main Door Assembly Complete (includes illus. nos. 1 through 10)
	881966	1	White Main Door Ring
	882305	1	Coral Wrinkle Blue Cold Rolled Steel Large Main Door Ring
10	882411	1	Extruded Steel Door Gasket
11	851083*	1	Front Panel Assembly
	851062*	1	Front Panel Assembly with E-Stop
12	170330	1	Friction Door Latch
13	154215	2	5/32" Pop Rivet
14	123553**	1	"Emergency Stop" (E-Stop) Push-Pull Button (for models mfd. as of February 20, 2007)
15	123506**	1	"Emergency Stop" (E-Stop) Nameplate (for models mfd. as of February 20, 2007)
16	123555**	1	Normally Open Contact Block (for models mfd. as of February 20, 2007)
17	123554**	1	Normally Closed Contact Block with Base (for models mfd. as of February 20, 2007)

* Specify color when ordering.

** Models mfd. prior to February 20, 2007 will require entire E-Stop assembly kit (P/N 887179).

Lint Door Assembly

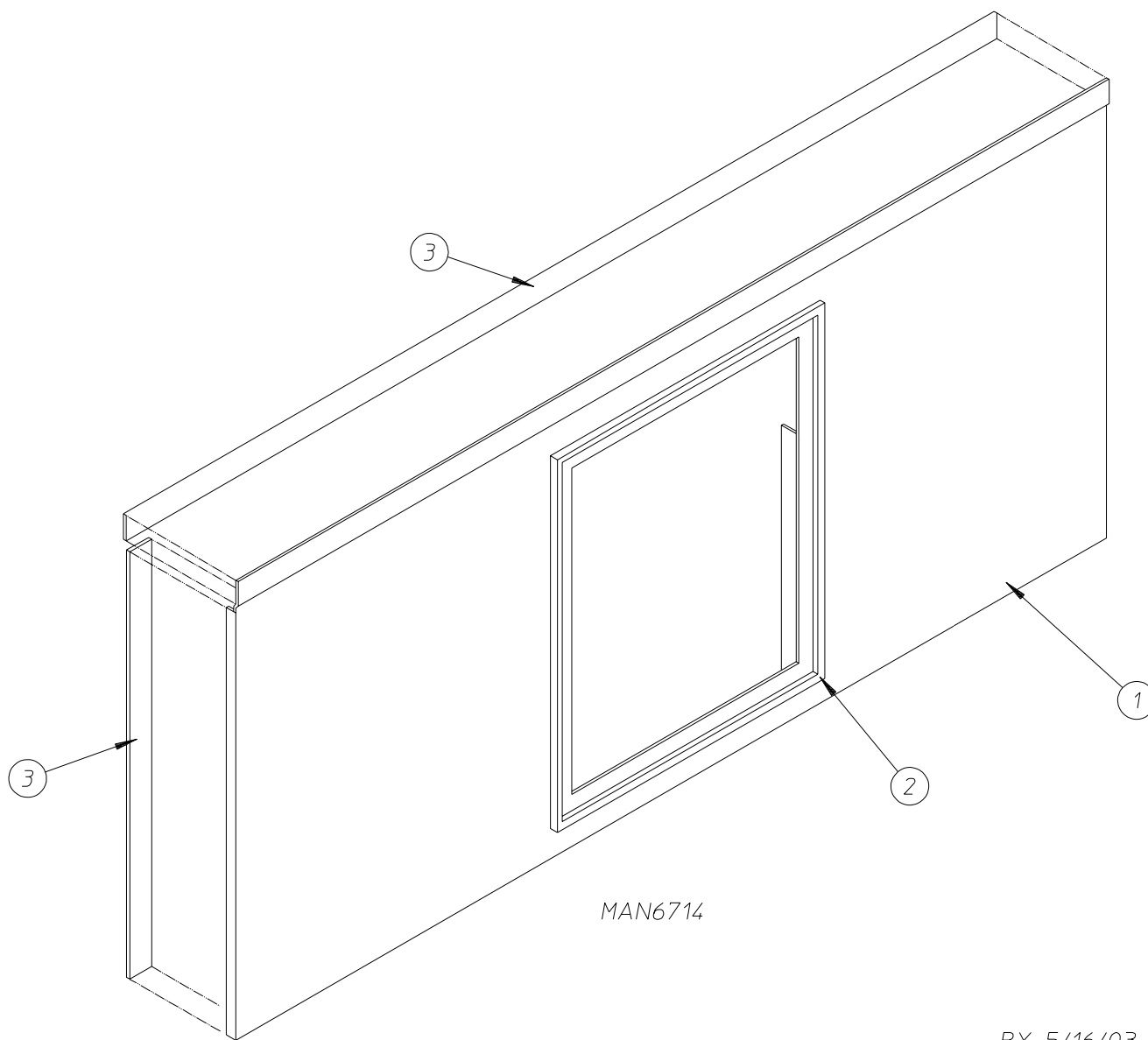

Illus. No.	Part No.	Qty.	Description
1*	820945	1	Lint Door Assembly (includes illus. nos. 1 through 3)
2	117607	6	1/4" x 3/8" Poron Foam
3	117604	9	Noise Suppression Tape (sold by the foot)

* Specify color when ordering.

Lint Drawer / Lint Drawer Switch Box Assemblies

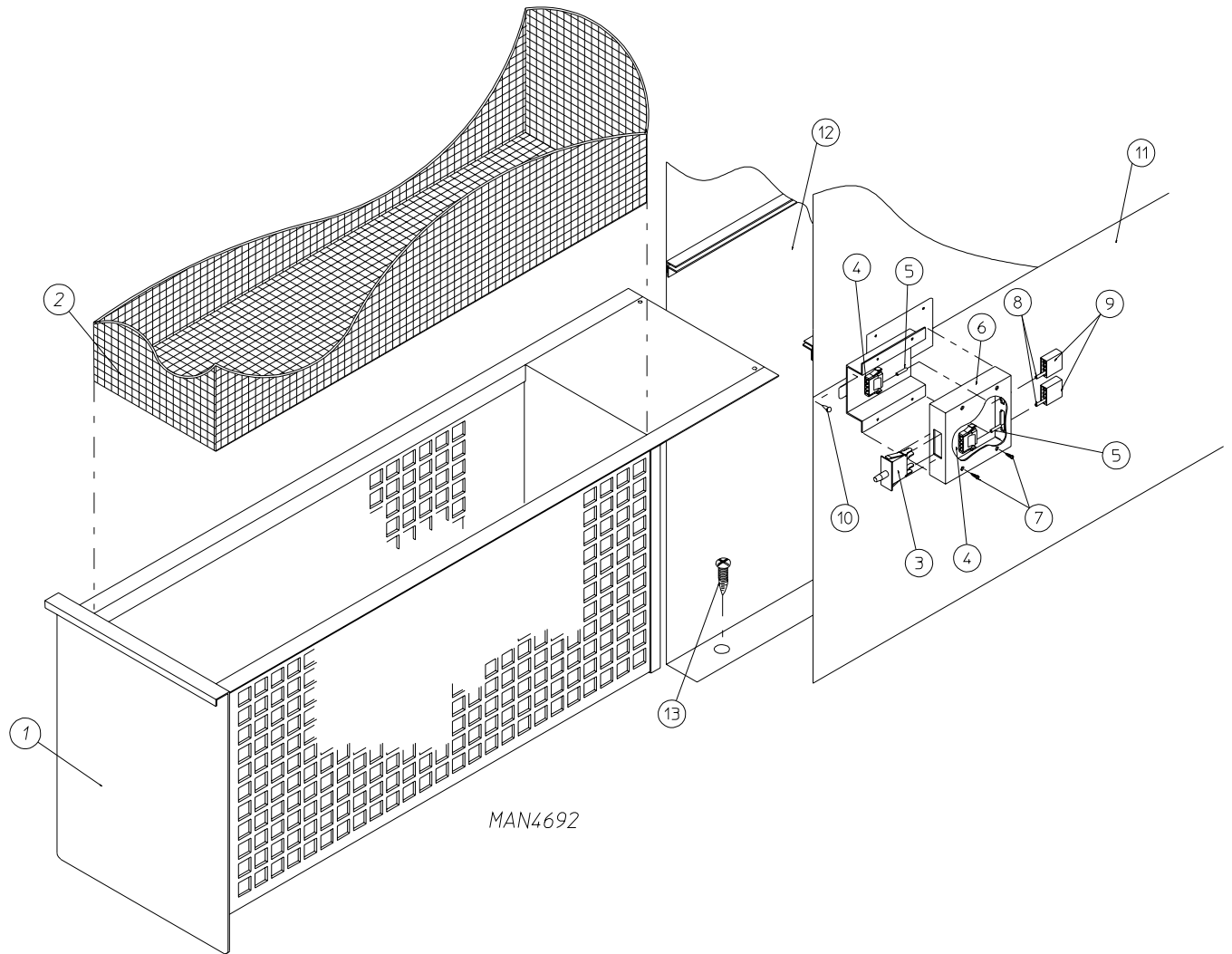

Illus. No.	Part No.	Qty.	Description
1*	821046	1	Lint Drawer Assembly
2	820925	1	Lint Screen Assembly Only
3	150002	2	#6-32 x 1" Phillips Round Head Machine Screw
4	122116	1	Lint Drawer Switch Only
5	153012	2	#8 Star Washer
6	152001	2	#8-32 x 3/8" Hex Nut
7	820138	1	Lint Drawer Switch Assembly Complete (includes illus. nos. 3 through 8)
	820137	1	Lint Drawer Switch Mounting Bracket Assembly Only (includes illus. nos. 3 and 4)
	321638	1	Lint Drawer Switch Mounting Bracket Only
8	150309	2	#10-16 x 1/2" Hex Head TEK Crimptite Screw
9	122604	2	4-Pin Connector
10	150301	2	#8-18 x 7/16" Phillips Pan Head TEK Screw
11	319076	1	Right-Hand Divider Panel
12	319077	1	Left-Hand Divider Panel
13	150301	14	#8-18 x 7/16" Phillips Pan Head TEK Screw

* Specify color when ordering.

Microprocessor Temperature Sensor Bracket Assembly

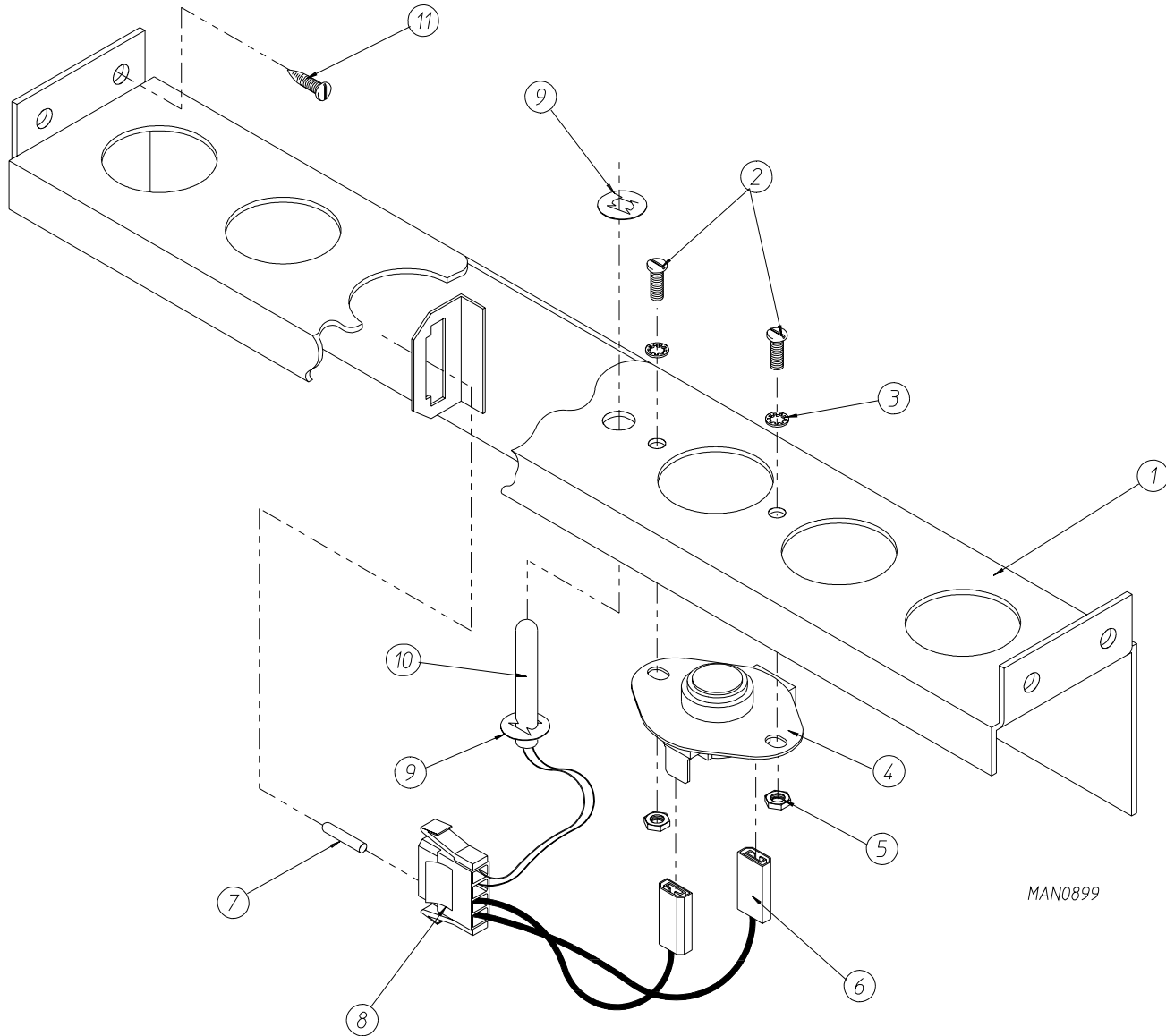

Illus. No.	Part No.	Qty.	Description
1	815931	1	Microprocessor Temperature Sensor Bracket Complete (includes illus. nos. 1 through 11)
	820967	1	Microprocessor Temperature Sensor Bracket Only
2	150005	2	#6-32 x 1/4" Phillips Round Head Machine Screw
3	153010	2	#6 Star Washer
4	130103	1	225° Large Automatic Reset Thermostat Only
5	152000	2	#6-32 Hex Nut
6	121028	2	1/4" x 0.032 Insulated Terminal
7	122701	4	Socket Terminal Only
	122801	1	Pin / Socket Extraction Tool ... Not Illustrated
8	122605	1	4-Pin Connector (female)
9	154007	2	1/4" Push-On Fastener
10	815961	1	1/4" Temperature Sensor Probe Assembly (includes illus. nos. 6 through 10)
11	150301	4	#8-18 x 7/16" Phillips Pan Head TEK Screw

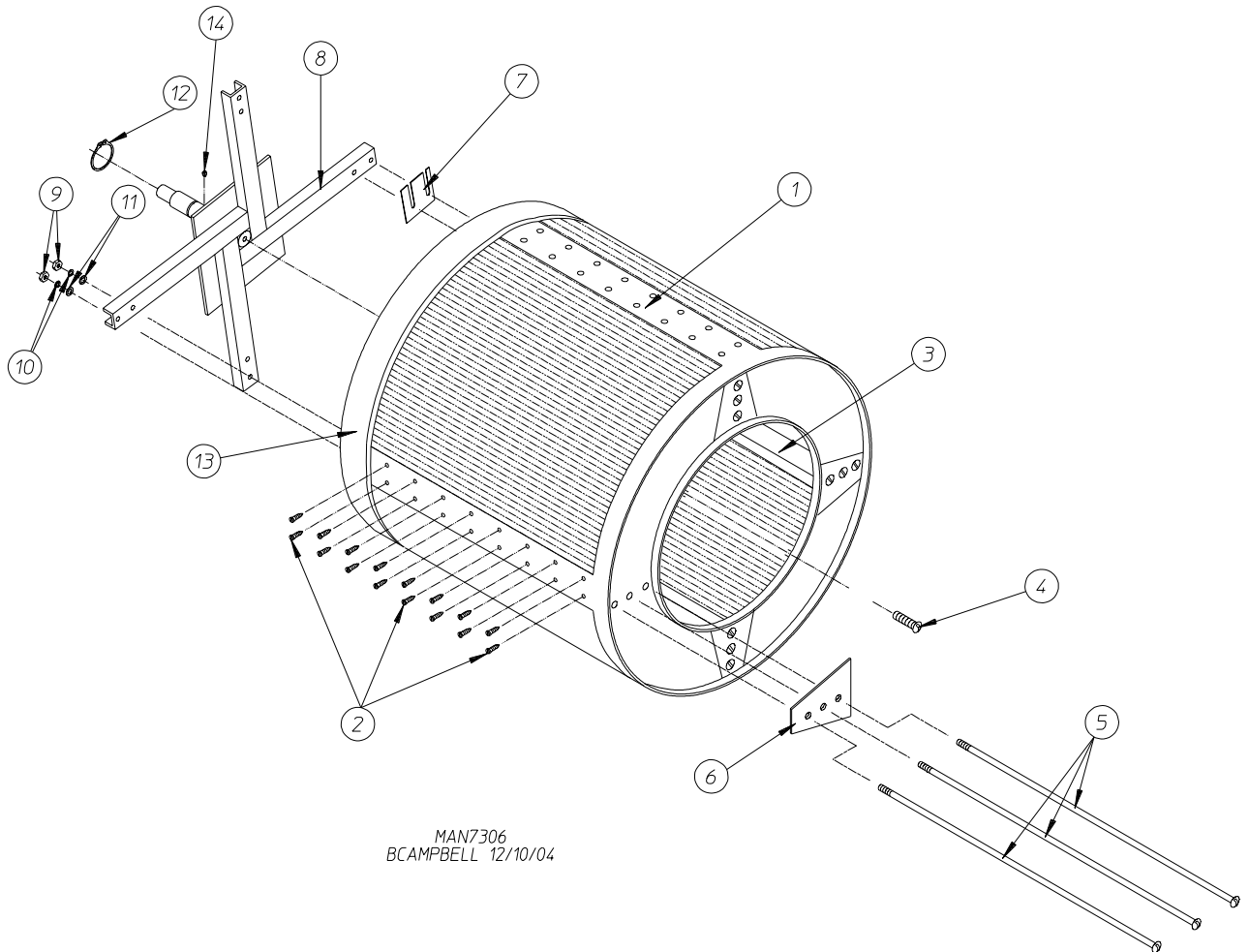

Illus. No.	Part No.	Qty.	Description
1	820979*	1	Galvanized Tumbler Only without Felt Collar
	821795	1	Galvanized Tumbler and Support Assembly Complete (includes illus. nos. 1 through 13)
	881640	1	Stainless Steel Tumbler and Support Assembly Complete (includes illus. nos. 1 through 13)
2	150309	64	#10-16 x 1/2" Hex Head TEK Crimptite Screw
3	332140	4	Galvanized Tumbler Rib Only
4	150500	1	5/16-18 x 3/4" Socket Button Head Screw
5	100910	12	1/2-13 x 44" Tie Rod
6	332139	4	Tumbler Reinforcing Plate Only
7	332177	**	Tumbler Shim Only
8	821191	1	Tumbler Support Only
9	152011	12	1/2-13 Hex Nut
10	153026	12	1/2" Lock Washer
11	153011	13	9/16" x 1-3/8" Flat Washer
12	100810	1	3-1/8" Retaining Ring
13	116007	1	Felt Collar Only
14	821002	1	Rotational 1 Magnet Holder Assembly

* Felt collar is not included and must be ordered separately.

** As required.

Tumbler Bearing Mount Assembly

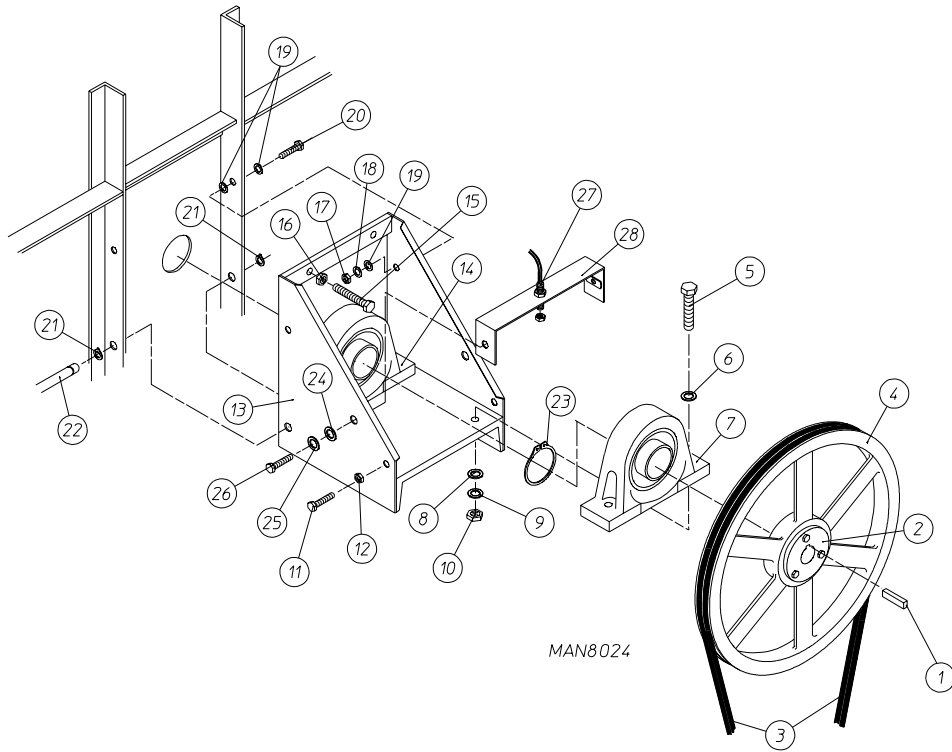

Illus. No.	Part No.	Qty.	Description
1	100703	1	1/2" x 1/2" x 2" Key
2	101217	1	2-1/2" SFX Bushing with Key
3*	100137	2	AB-91 V-Belt (tumbler to idler)
4	101182	1	25" Tumbler Pulley Only
5	150602	4	5/8-11 x 3" Hex Head Machine Bolt
6	153016	4	5/8" Flat Washer
7	881775	1	2-1/2" Pillow Block Bearing Only
8	153016	4	5/8" Flat Washer
9	153015	4	5/8" Lock Washer
10	152010	4	5/8-11 Hex Nut
11	150600	2	3/8-16 x 1-1/2" Hex Head Machine Bolt
12	152005	2	3/8-16 Hex Nut
13	821175	1	Tumbler Bearing Mount Only
14	880883	1	3-1/8" Pillow Block Bearing Only
15	150604	2	1/2-20 x 3" Tap Bolt
16	152012	2	1/2-20 Hex Nut
17	152005	2	3/8-16 Hex Nut
18	153005	2	3/8" Lock Washer
19	153004	6	3/8" Flat Washer
20	150600	2	3/8-16 x 1-1/2" Hex Head Machine Bolt
	820931	1	Tumbler Bearing Box Mount / Hardware (includes illus. nos. 11, 12, 18, 19, 21, 22)
21	100801	2	5/8" Retaining Ring
22	332153	1	5/8" Hinge Pin
23	100810	1	3-1/8" Retaining Ring
24	153018	2	1/4" Flat Washer
25	153007	2	1/4" Lock Washer
26	150512	2	1/4-20 x 1/2" Hex Head Machine Bolt
27	822735	1	Rotational Sensor Assembly
28	820997	1	Rotational Sensor Mounting Bracket

* Replace in matched sets (both belts).

Idler Bearing Mount Assembly

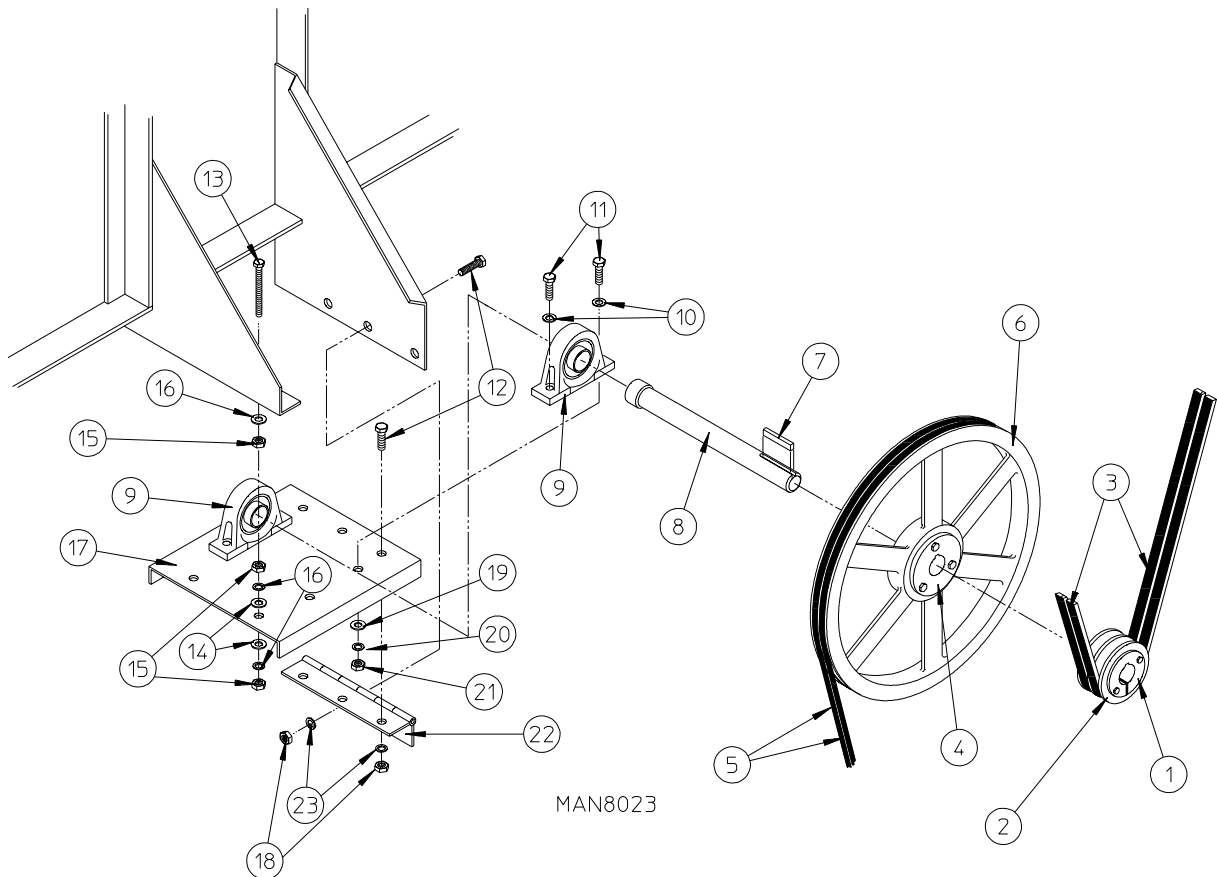

Illus. No.	Part No.	Qty.	Description
1	101152	1	1-3/8" Bushing with Setscrew
2	101143	1	2B3.8 SH Sheave
3*	100137	2	AB-91 V-Belt (tumbler to idler)
4	101184	1	SK 1-3/8" Bushing with Setscrew
5*	100102	2	3V-740 V-Belt (idler to motor)
6	101112	1	19" Idler Pulley
7	100715	1	1/4" x 1/4" x 4-5/8" Key
8	332152	1	Idler Shaft Only
9	880779	2	1-3/8" Pillow Block Bearing
10	153011	4	9/16" ID x 1-3/8" OD Flat Washer
11	150606	4	1/2-13 x 2" Tap Bolt
12	150501	6	5/16-18 x 3/4" Tap Bolt
13	152034	2	3/8-16 x 3-1/2" Hex Head Machine Bolt
14	153004	6	3/8" x 1" Flat Washer
15	152005	6	3/8-16 Hex Nut
16	153005	4	3/8" Lock Washer
17	820932	1	Idler Bearing Mount Assembly Complete (includes illus. nos. 7 through 11 and 17 through 23)
	332151	1	Idler Bearing Mount Only
18	152004	6	5/16-18 Hex Nut
19	153011	4	9/16" ID x 1-3/8" OD Flat Washer
20	153026	4	1/2" Lock Washer
21	152011	4	1/2-13 Hex Nut
22	103005	1	Idler Adjustment Hinge Only
23	153002	6	5/16" Lock Washer

* Replace in matched sets (both belts).

Direct Spark Ignition Burner Assembly

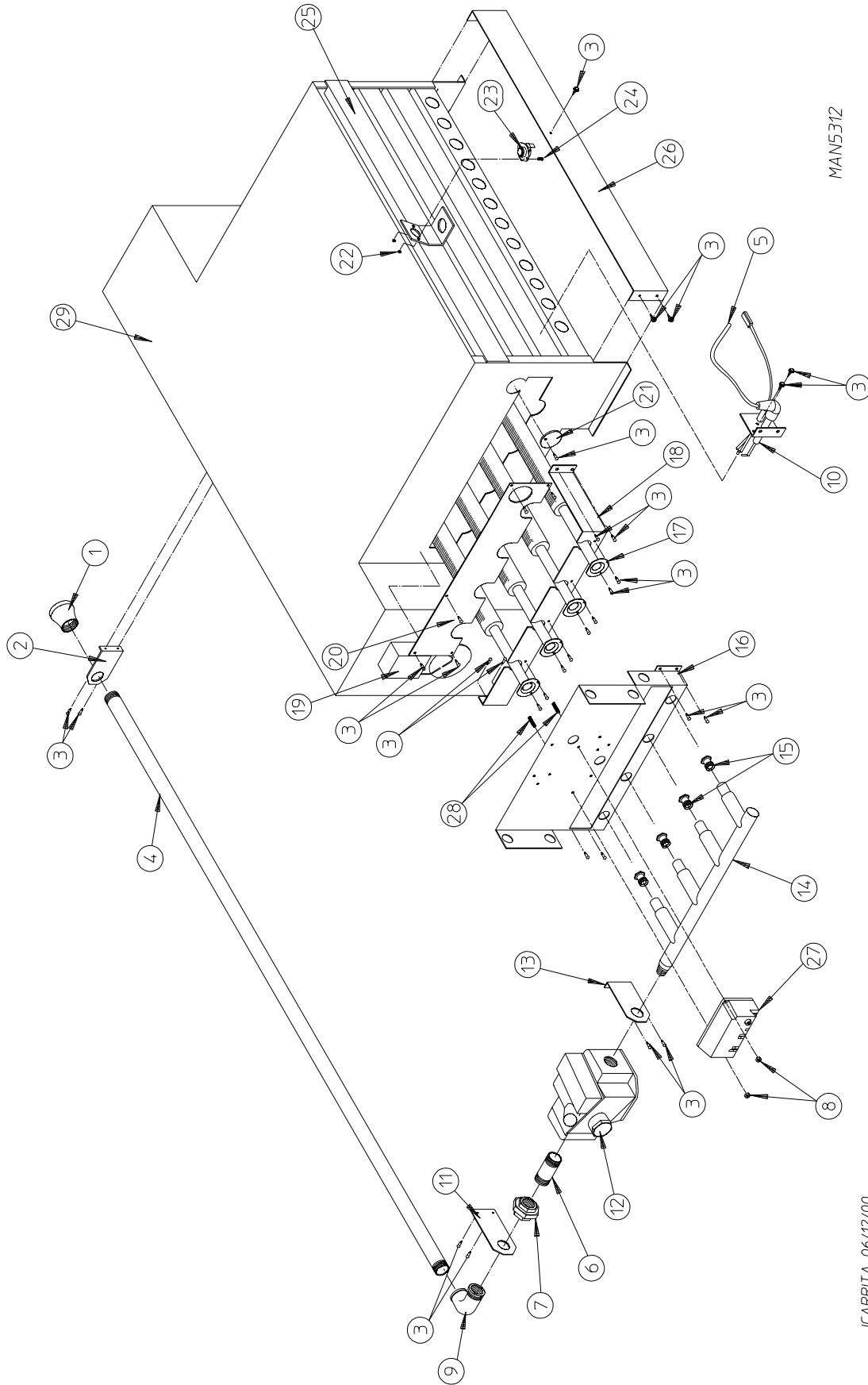

MAN5312

JCARRITA 06/12/00

Direct Spark Ignition Burner Assembly

<u>Illus. No.</u>	<u>Part No.</u>	<u>Qty.</u>	<u>Description</u>
1	142929	1	1-1/2" to 1" Reducing Coupling
2	332117	1	Pipe Bracket
3	150309	33	#10-16 x 1/2" Hex Head TEK Crimptite Screw
4	142583	1	1" x 40" Nipple
5	884278	1	High Voltage Cable (for models with spade style connector at module)
	128919*	1	High Voltage Ignition Cable with Cap 36" (for modules with spike style connector)
6	142808	1	1" x 3" Nipple
7	142602	1	1" Union
8	152013	2	#6-32 Hex Nut
9	142507	1	1" x 90° Street Elbow
10	884265	1	Direct Spark Ignition Ignitor
11	332487	1	Gas Pipe Bracket Straight Extended
12	140017	1	1" 24 VAC Redundant Gas Valve (natural gas)
	882945	1	1" 24 VAC Gas Valve (propane gas)
13	332486	1	Gas Pipe Bracket Bent Extended
14	141240	1	4-Port Manifold Only
15*	140839	4	#2 Burner Orifice (natural gas)
	140820	4	#29 Burner Orifice (propane gas)
16	390169	1	Direct Spark Ignition Mount Manifold Rest
17	881492	4	Burner Tube Only
18	332121	1	Burner Tube Support Only
19	————	1	Sail Switch (refer to Sail Switch Assembly on page 32)
20	332113	1	Burner Box Cover Plate
21	331290	1	Ignitor / Flame-Probe Sight Hole Disc
22	151000	2	#6-32 Pal Nut
23	130201	1	330° Manual Reset Hi-Limit
24	150005	2	#6-32 x 1/4" Phillips Round Head Machine Screw
25	821457	1	Burner Hi-Limit Bracket
26	332256	1	Large Dryer Propane Burner Baffle (propane models Only)
27	883849	1	Direct Spark Ignition Module with High Voltage Wire
28	153562	2	#6-32 x 3/4" Clinch Stud
29	835037**	1	Burner Assembly (natural gas) Complete Less Orifice
	821960**	1	Burner Assembly (propane gas) Complete Less Orifice
	820904	1	Burner Box Only
	880978	1	AD-170SE Propane Conversion Kit

* Consult factory for elevations over 2,000 feet.

** Orifices are not included and must be ordered separately.

Totally Enclosed, Fan-Cooled Tumbler Motor Mount Assembly

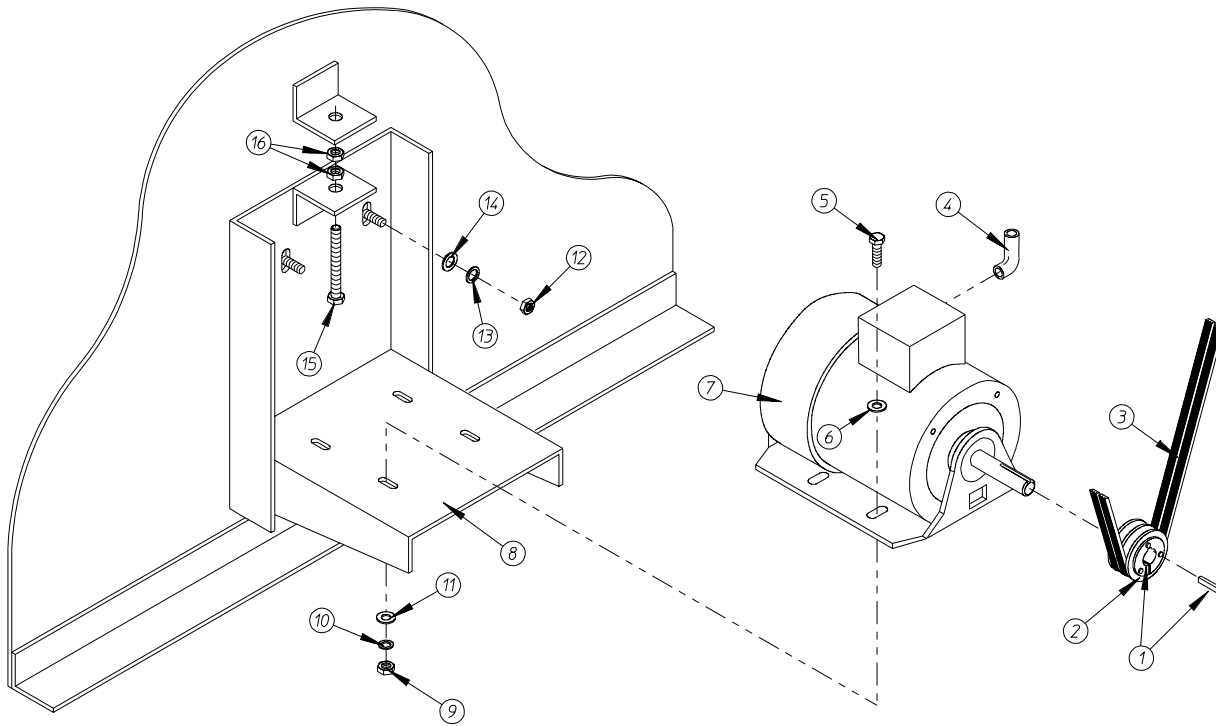

MAN0329

Illus. No.	Part No.	Qty.	Description
1	101121	1	5/8" SK Bushing
2	101114	1	2.65" Pulley (for 60 Hz models Only)
	101120	1	3.15" Pulley (for 50 Hz models Only)
3*	100102	2	3V-740 V-Belt (motor to idler)
4	120200	1	3/8" x 90° Connector
5	150501	4	5/16-18 x 3/4" Hex Head Machine Bolt
6	153001	4	5/16" Flat Washer
7	100050	1	1 hp 208/230/380/460v 3ø 50/60 Hz Totally Enclosed, Fan-Cooled Motor (56Z frame)
8	800952	1	Tumbler Motor Mount Only (56Z frame)
	820941	1	(50/60 Hz) Totally Enclosed, Fan-Cooled Tumbler Motor Mount Assembly Complete (includes illus. nos. 1, 4 through 11, 15, and 16) NOTE: MOTOR PULLEY MUST BE ORDERED SEPARATELY
9	152004	4	5/16-18 Hex Nut
10	153002	4	5/16" Lock Washer
11	153001	4	5/16" Flat Washer
12	152004	4	5/16-18 Hex Nut
13	153002	4	5/16" Lock Washer
14	153001	4	5/16" Flat Washer
15	150619	1	3/8-16 x 3" Hex Head Machine Bolt
16	152005	2	3/8-16 Hex Nut

* Replace in matched sets (both belts).

IMPORTANT: For voltages higher than 460v, contact the factory for correct part number of motor or motor mount assembly.

Blower Motor Mount Assembly

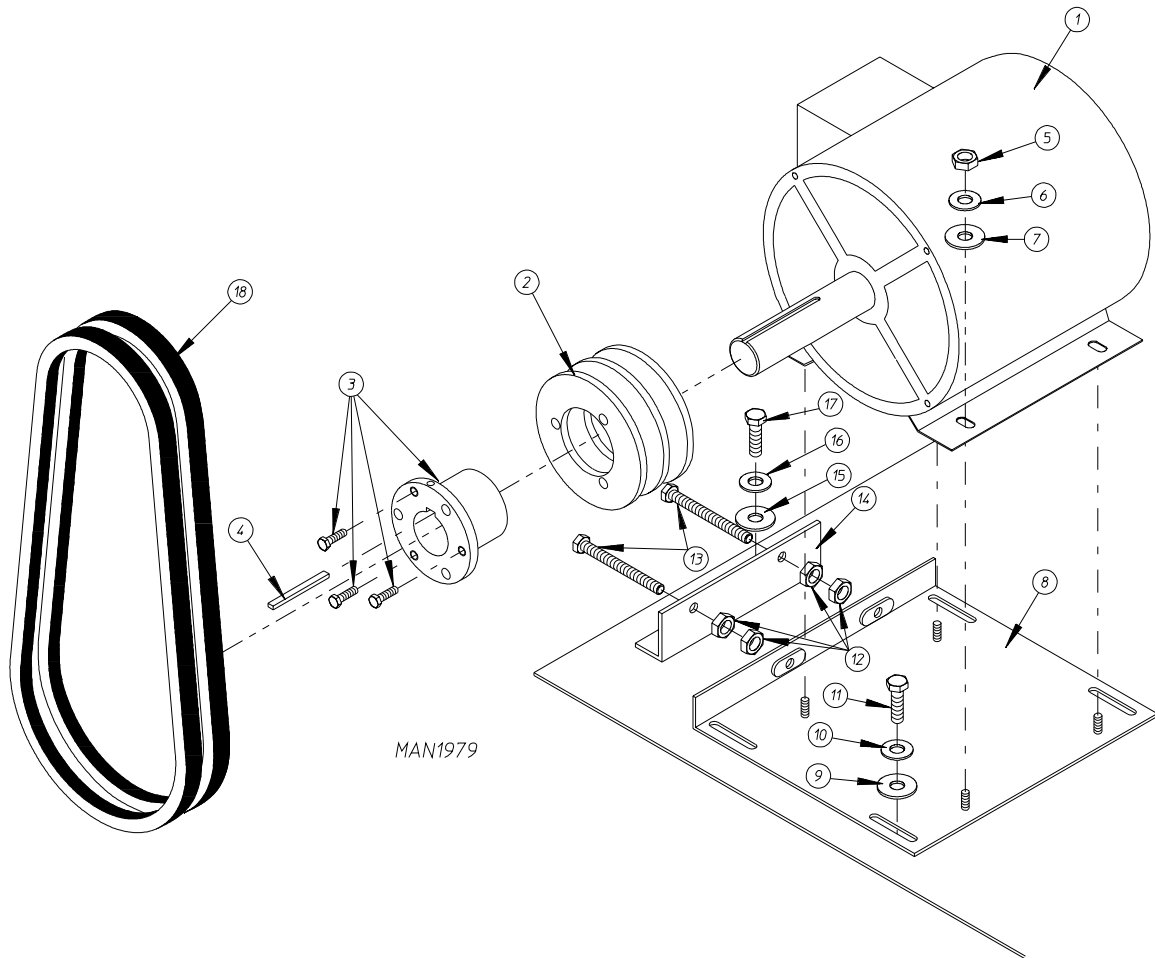

Illus. No.	Part No.	Qty.	Description
1	181149	1	7.5 hp 208-460V 3 ϕ Motor (for 60 Hz models)
	100046	1	7.5 hp 208-416V 3 ϕ Motor (for 50 Hz models Only)
2	101148	1	SB x 4.0 Motor Pulley (for 60 Hz models Only)
	101147	1	SB x 4.8 Motor Pulley (for 50 Hz models Only)
3	101152	1	SH x 1-3/8" Bushing (for 60 Hz models Only)
	101194	1	SDS x 1-3/8" Bushing (for 50 Hz models Only)
4	100706	1	5/16" x 5/16" x 1-3/8" Key
5	152004	4	5/16-18 Hex Nut
6	153002	4	5/16" Lock Washer
7	153001	4	5/16" Flat Washer
8	821091	1	Motor Mount Adjustment Plate Only
9	153001	4	5/16" Flat Washer
10	153002	4	5/16" Lock Washer
11	150501	4	5/16-18 x 3/4" Hex Head Machine Bolt
12	152004	4	5/16-18 Hex Nut
13	150503	2	5/16-18 x 2" Hex Head Machine Bolt
14	332322	1	Motor Mount Adjustment Angle Only
15	153001	2	5/16" Flat Washer
16	153002	2	5/16" Lock Washer
17	150501	2	5/16-18 x 3/4" Hex Head Machine Bolt
18*	100128	2	BX-50 Cogged Belt (motor to fan shaft) for 60 Hz Models Only
	100164	2	BX-51 Cogged Belt (motor to fan shaft) for 50 Hz Models Only

* Replace in matched sets (both belts).

Fan Shaft Mount Assembly

For Gas Models Only

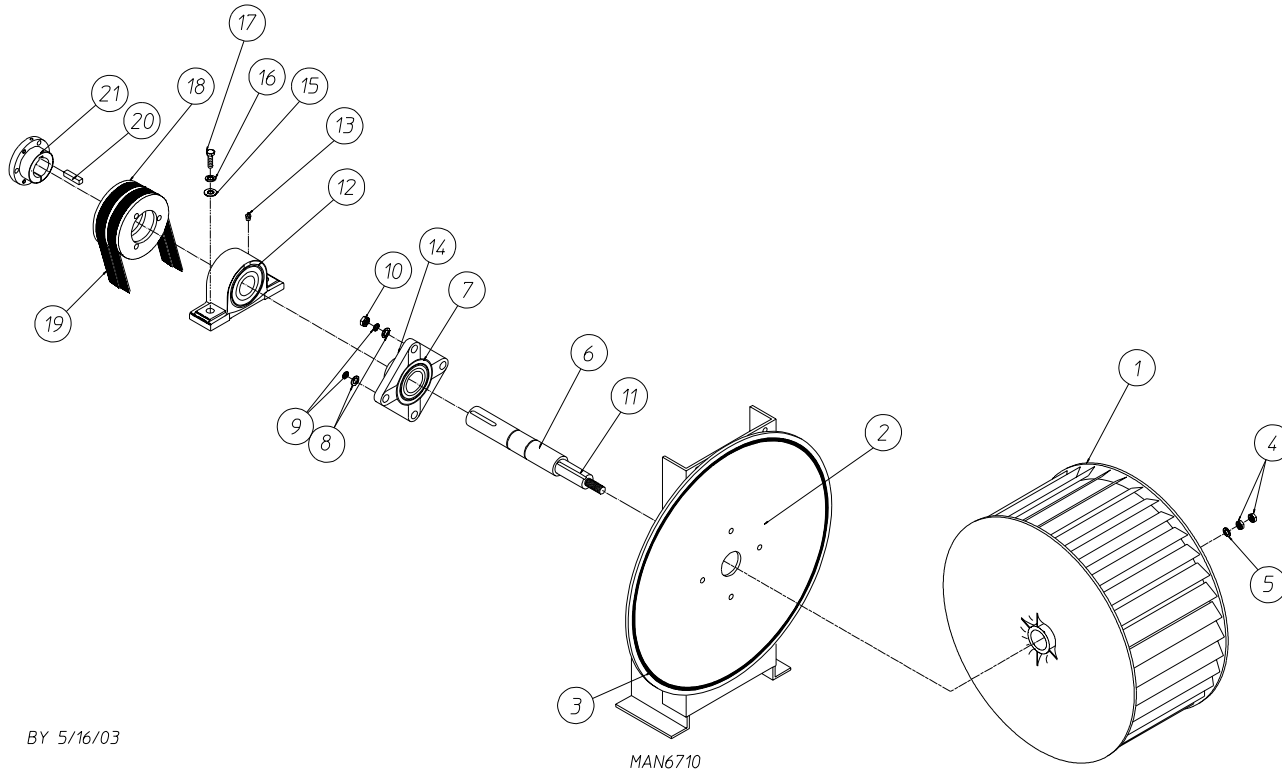

BY 5/16/03

MAN6710

Illus. No.	Part No.	Qty.	Description
1	100612	1	1-1/4" Bore x 15" Diameter x 6" Blower (fan) Wheel
2	821078	1	Fan Shaft Mount Assembly Complete (includes illus. nos. 1 through 21)
	821073	1	Fan Shaft Mount Only
3	117604	4	Noise Suppression Tape (sold by the foot)
4	152006	2	1/2-20 Left-Hand Jam Nut
5	153065	1	1-1/2" Flat Washer
6	332280	1	Fan Shaft Only
7	881061	1	1-3/8" Flange Bearing with Setscrew and Grease Fitting
8	153004	4	3/8" Flat Washer
9	153005	4	3/8" Lock Washer
10	152005	4	3/8-16 Hex Nut
11	100704	1	1/4" x 1/4" x 1-3/4" Key
12	880779	1	1-3/8" Pillow Block Bearing
13	170511	2	1/8-27 N.P.T. ZIRC Grease Fitting Only
14	154321	4	5/16-24 x 3/8" Black Allen Setscrew (knurl cup)
15	153004	2	3/8" Flat Washer
16	153005	2	3/8" Lock Washer
17	150600	2	3/8-16 x 1-1/2" Tap Bolt
18	101177	1	2B x 5.8 Pulley
19*	100128	2	BX-50 Cogged Belt (fan shaft to motor) for 60 Hz Models Only
	100164	2	BX-51 Cogged Belt (fan shaft to motor) for 50 Hz Models Only
20	100706	1	5/16" x 5/16" x 1-3/8" Key
21	101194	1	SDS x 1-3/8" Bushing Only

* Replace in matched sets (both belts).

Fan Shaft Mount Assembly

For Steam Models Only

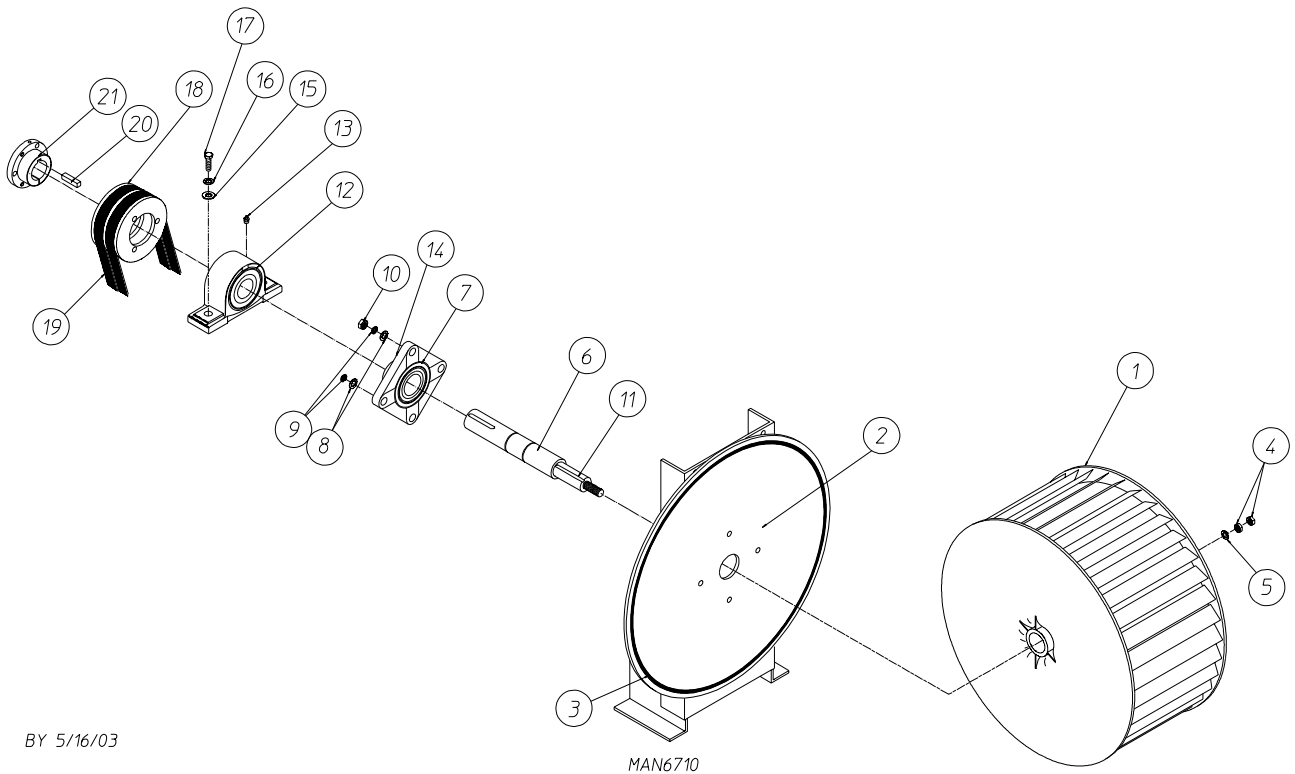

BY 5/16/03

MAN6710

Illus. No.	Part No.	Qty.	Description
1	100612	1	1-1/4" Bore x 15" Diameter x 6" Blower (fan) Wheel
2	821077	1	Fan Shaft Mount Assembly Complete (includes illus. nos. 1 through 21)
	821073	1	Fan Shaft Mount Only
3	117604	4	Noise Suppression Tape (sold by the foot)
4	152006	2	1/2-20 Left-Hand Jam Nut
5	153065	1	1-1/2" Flat Washer
6	332280	1	Fan Shaft Only
7	881061	1	1-3/8" Flange Bearing with Setscrew and Grease Fitting
8	153004	4	3/8" Flat Washer
9	153005	4	3/8" Lock Washer
10	152005	4	3/8-16 Hex Nut
11	100704	1	1/4" x 1/4" x 1-3/4" Key
12	880779	1	1-3/8" Pillow Block Bearing
13	170511	2	1/8-27 N.P.T. ZIRC Grease Fitting Only
14	154321	4	5/16-24 x 3/8" Black Allen Setscrew
15	153004	2	3/8" Flat Washer
16	153005	2	3/8" Lock Washer
17	150600	2	3/8-16 x 1-1/2" Tap Bolt
18	101135	1	2B x 5.4 Pulley
19*	100128	2	BX-50 Cogged Belt (fan shaft to motor) for 60 Hz Models Only
	100164	2	BX-51 Cogged Belt (fan shaft to motor) for 50 Hz Models Only
20	100706	1	5/16" x 5/16" x 1-3/8" Key
21	101194	1	SDS x 1-3/8" Bushing Only

* Replace in matched sets (both belts).

Dual Timer

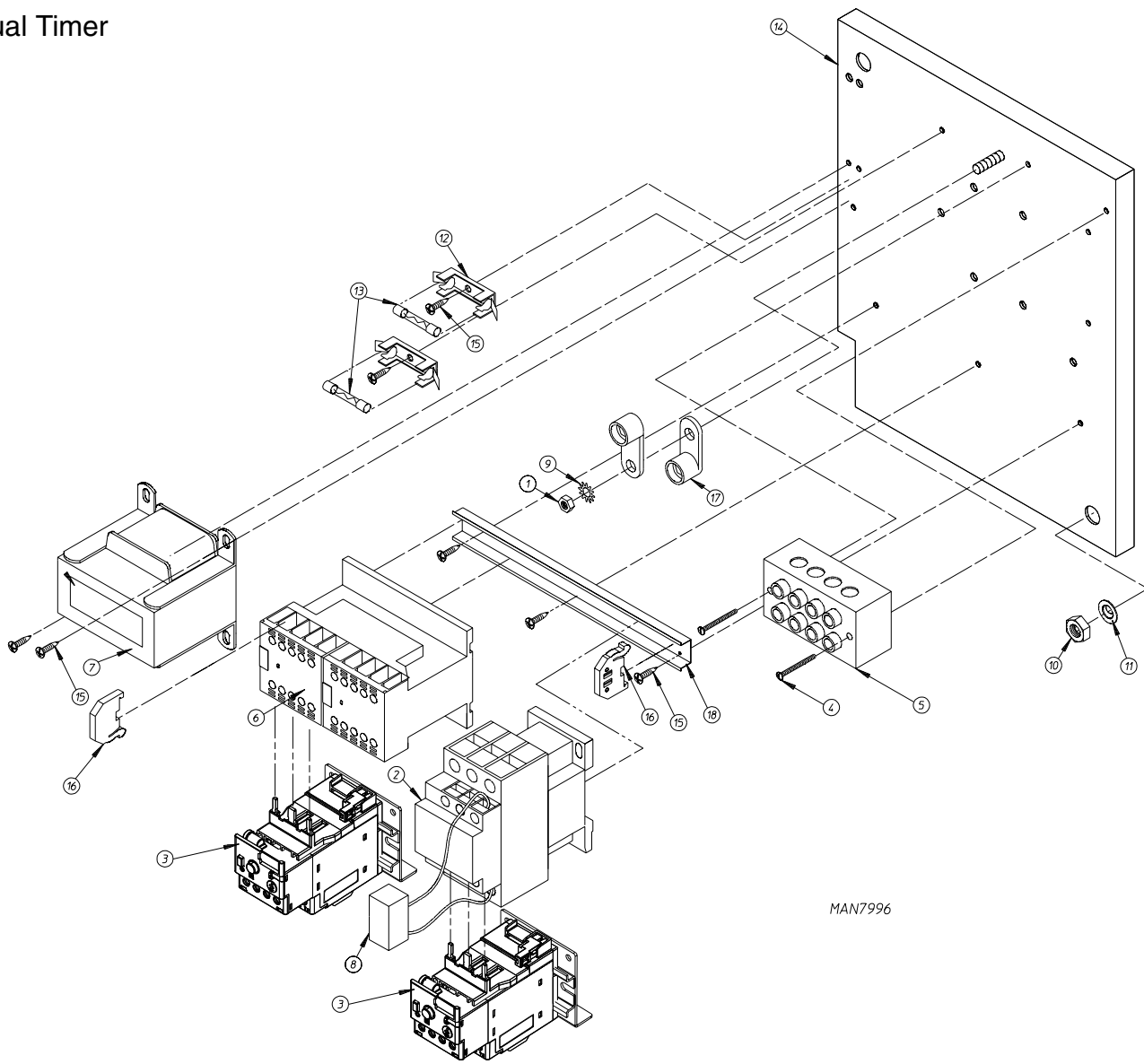

MAN7996

Illus. No.	Part No.	Qty.	Description
1	152002	1	1/4-20 Hex Nut
2	131393	1	3ø Contactor
3	801891	2	1.0-5 Amp Overload Rail adj with Component
4	150539	2	#8 x 1-1/4" Pan Head Phillips AB Zinc Screw
5	120701	1	4-Position Terminal Block
6	132497	1	Reversing Contactor
7	132109	1	208-240V Transformer Assembly
8	137015	1	Arc Suppressor with 3" Insul Leads
9	153021	1	1/4" Exterior/Interior Shakeproof Washer
10	152004	1	5/16-18 Hex Nut
11	153002	1	5/16" Lock Washer
12	136008	2	Fuse Holder
13	136057	2	1/2-Amp 3AG Slo-Blo Fuse
14	332346	1	Relay Panel
15	150301	7	#8-18 x 7/16" Phillips Head TEK Screw
16	120774	2	End Stop for Din 35 Rail
17	121010	2	L70 14-4 Terminal Lug
18	120768	7-3/8"	35 x 15 mm Din Rail

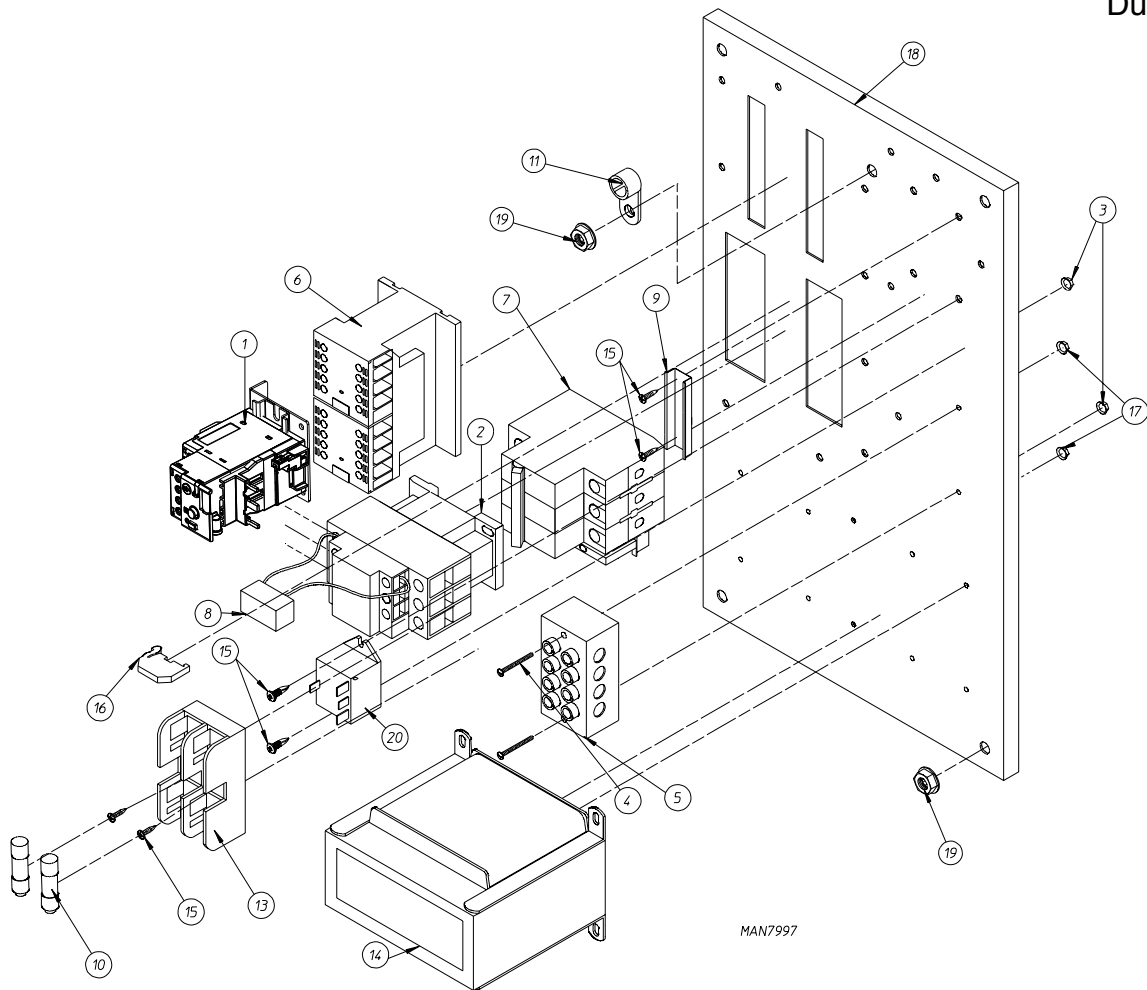

MAN7997

Illus. No.	Part No.	Qty.	Description
1	801890	1	5.4-27 Overload Rail Adjust with Component
2	131393	1	18A Contactor
3	151001	2	#8-32 Pal Nut
4	150009	2	#6-32 x 1-1/2" Phillips Round Head Machine Screw
5	120701	1	4-Position Terminal Block
6	131383	1	Reversing Contactor with Suppression
7	135499	1	3-Pole 25A Circuit Breaker
8	137015	1	Arc Suppressor with 3" Insulation Leads
9	120768	2"	35 x 15mm Din Rail
10	136114	2	1-Amp Time Delay Class C Fuse
11	121012	1	Ground Lug
12	150302	2	6" x 3/8" TEK Screw
13	136037	1	2-Pole 1-Amp Circuit Breaker
14	815818	1	460-24V Step Down Transformer 300VA
15	150301	4	#8-18 x 7/16" Phillips Head TEK Screw
16	120774	1	End Stop for Din 35 Rail
17	15100	2	#6-32 Pal Nut
18	320817	1	Control Panel
19	152014	2	1/4-20 Free Spin Wash Nut
20	131406	1	Relay SPST 24V Panel
	815889	1	Relay Panel Plug Harness ... Not Illustrated
	815898	1	Misc. Relay Panel Wiring ... Not Illustrated
	815834	1	Drive and Blower Motor Contactor Wiring ... Not Illustrated

Microprocessor Reversing Contactor Mounting Panel Assembly

For 208-240V Transformers

TERMINAL BLOCK MOUNTING ORIENTATION

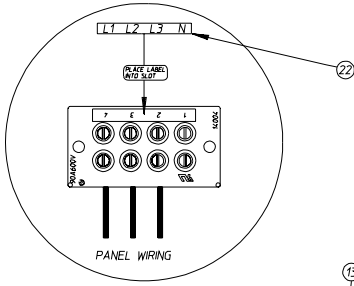

"DETAIL"

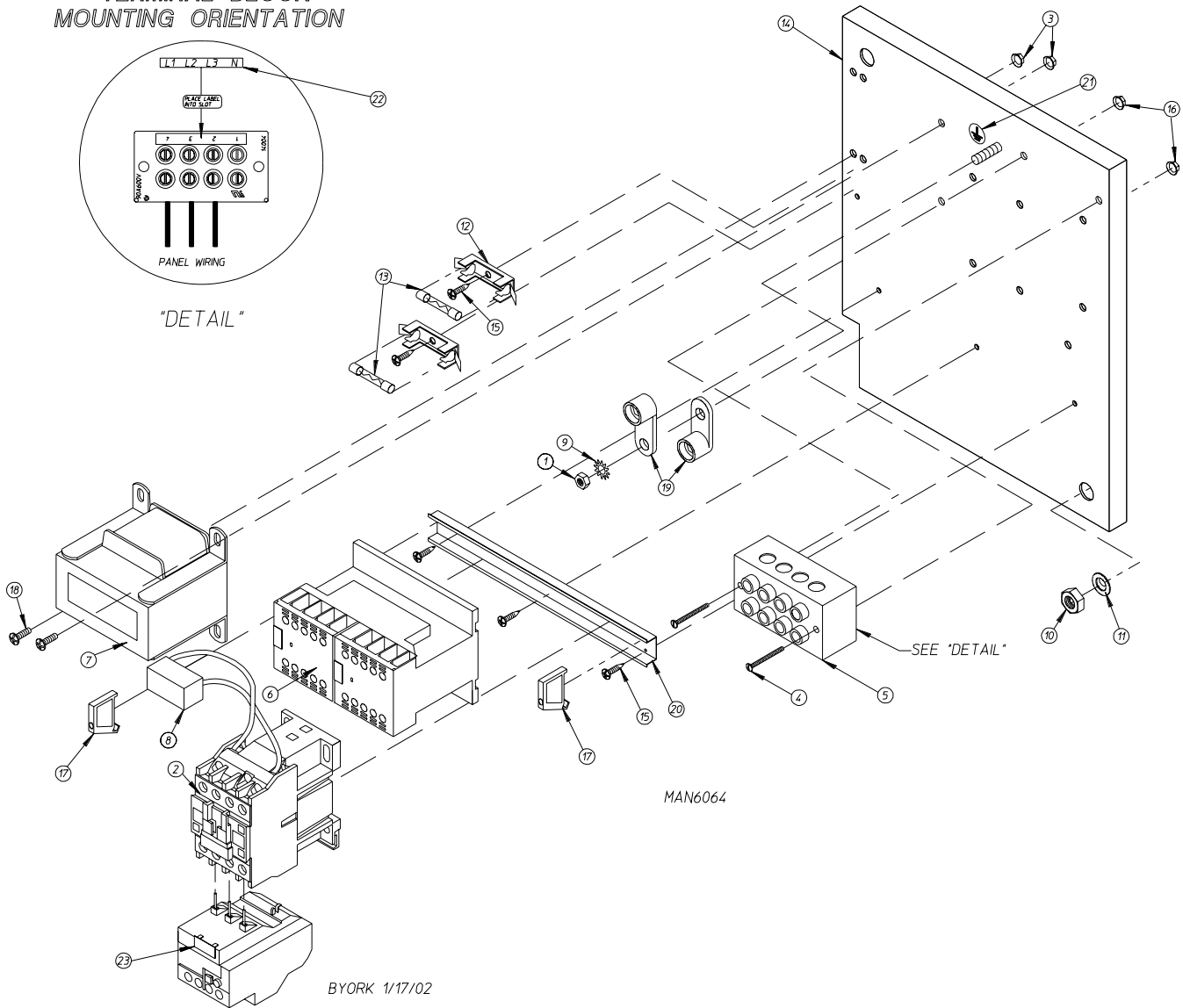

Microprocessor Reversing Contactor Mounting Panel Assembly

For 208-240V Transformers

<u>Illus. No.</u>	<u>Part No.</u>	<u>Qty.</u>	<u>Description</u>
1	152002	1	1/4-20 Hex Nut
2	131393	1	Contactor – 24 VAC
3	151001	2	#8-32 Pal Nut
4	150009	2	#6-32 x 1-1/4" Phillips Round Head Machine Screw
5	120701	1	4-Position Power Distribution Block
6	132497	1	Reversing Contactor – 24 Vac
7	132109	1	208-240V Transformer Assembly
8	137015	1	Arc Suppressor
9	153021	1	1/4" Ext / Int Shake Proof Washer
10	152004	1	5/16-18 Hex Nut
11	153002	1	5/16" Lock Washer
12	136008	2	Fuse Block / Holder
13	136057	2	1/2-Amp (Slo-Blo) Fuse
14	332346	1	Contactor / Relay Mounting Panel Only
15	150301	5	#8-18 x 7/16" Phillips Pan Head TEK Screw
16	151000	2	#6-32 Pal Nut
17	120774	2	End Stop / Bracket
18	150108	2	#8-32 x 1/2" Pan Head Machine Screw
19	121010	1	L-70 Ground Lug
20	120768	7-3/4"	Din Mounting Rail (sold by the inch)
21	112075	1	Ground Label
22	112068	1	3-Phase (3ø) Power Input Label
23	801890	1	Overload
	825267	1	Contactor Wiring ... Not Illustrated
	829053	1	Relay Panel Wiring ... Not Illustrated

Microprocessor Reversing Contactor Mounting Panel Assembly

For 380-416V Transformers

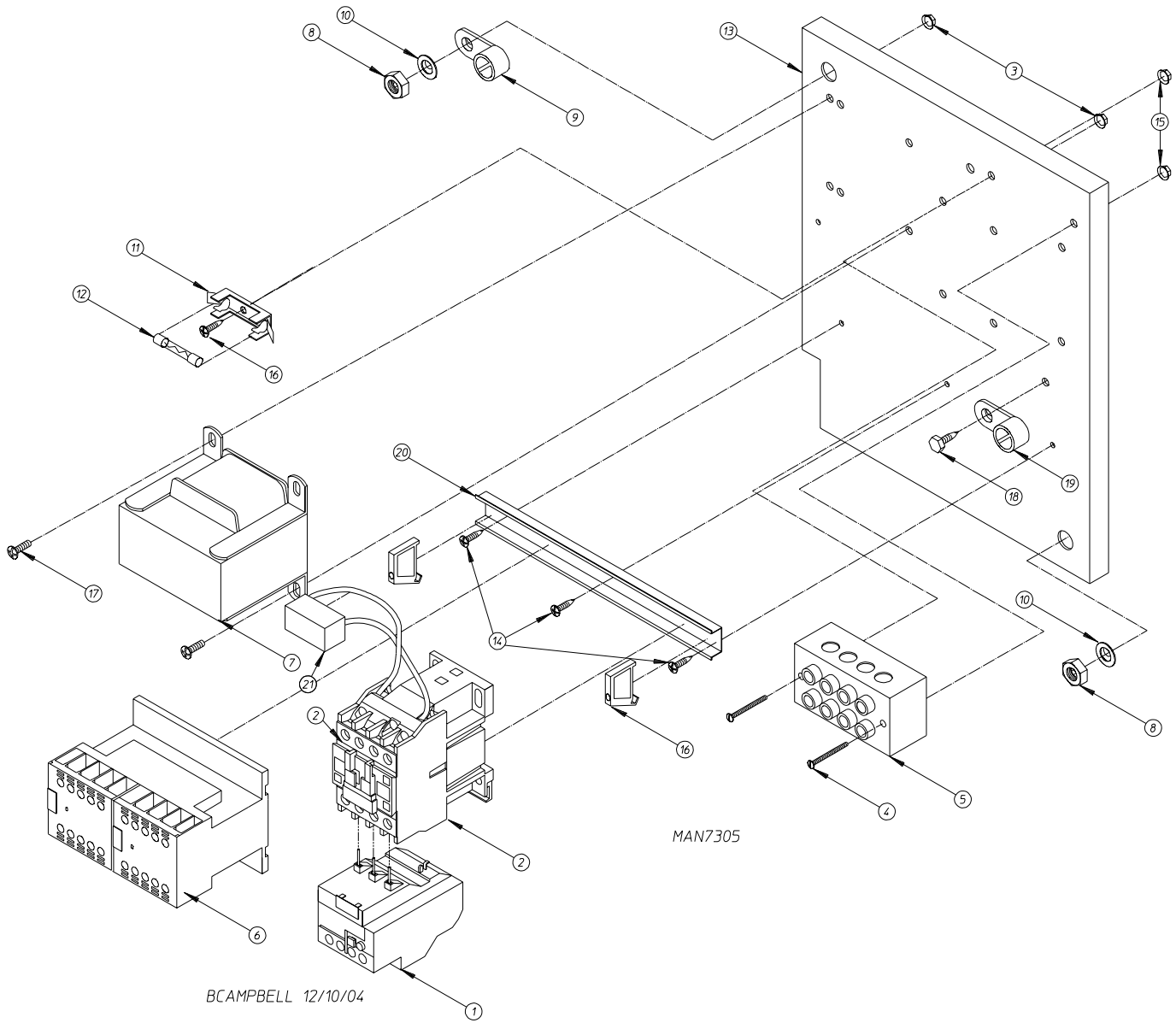

Microprocessor Reversing Contactor Mounting Panel Assembly

For 380-416V Transformers

<u>Illus. No.</u>	<u>Part No.</u>	<u>Qty.</u>	<u>Description</u>
1	132467	1	9-13-amp Overload
2	131393	1	Contactor – 24 VAC
3	151001	2	#8-32 Pal Nut
4	150009	2	#6-32 x 1-1/2" Phillips Round Head Machine Screw
5	120701	1	4-Position Power Distribution Block
6	132497	1	Reversing Contactor
7	801580	1	Transformer (380-416 volt / 3 ϕ)
8	152004	2	5/16-18 Hex Nut
9	121012	1	Ground Lug
10	153002	2	5/16" Lock Washer
11	136008	1	Fuse Block / Holder
12	136057	1	1/2-amp (Slo-Blo) Fuse
13	332346	1	Contactor / Relay Mounting Panel Only
14	150301	4	#8-18 x 7/16" Phillips Pan Head TEK Screw
15	151000	2	#6-32 Pal Nut
16	120765	2	End Stop / Bracket
17	150108	2	#8-32 x 1/2" Pan Head Machine Screw
18	150297	1	#10 x 1/2" Hex Washer TEK Screw
19	121010	1	L-70 Ground Lug
20	120768	7-3/4"	Din Mounting Rail (sold by the inch)
	830180	1	Relay Panel Wiring ... Not Illustrated
	825267	1	Drive / Blower Motor Contactor Wiring ... Not Illustrated
21	137015	1	Arc Suppressor

Microprocessor Reversing Contactor Mounting Panel Assembly

For 460-480V Transformers

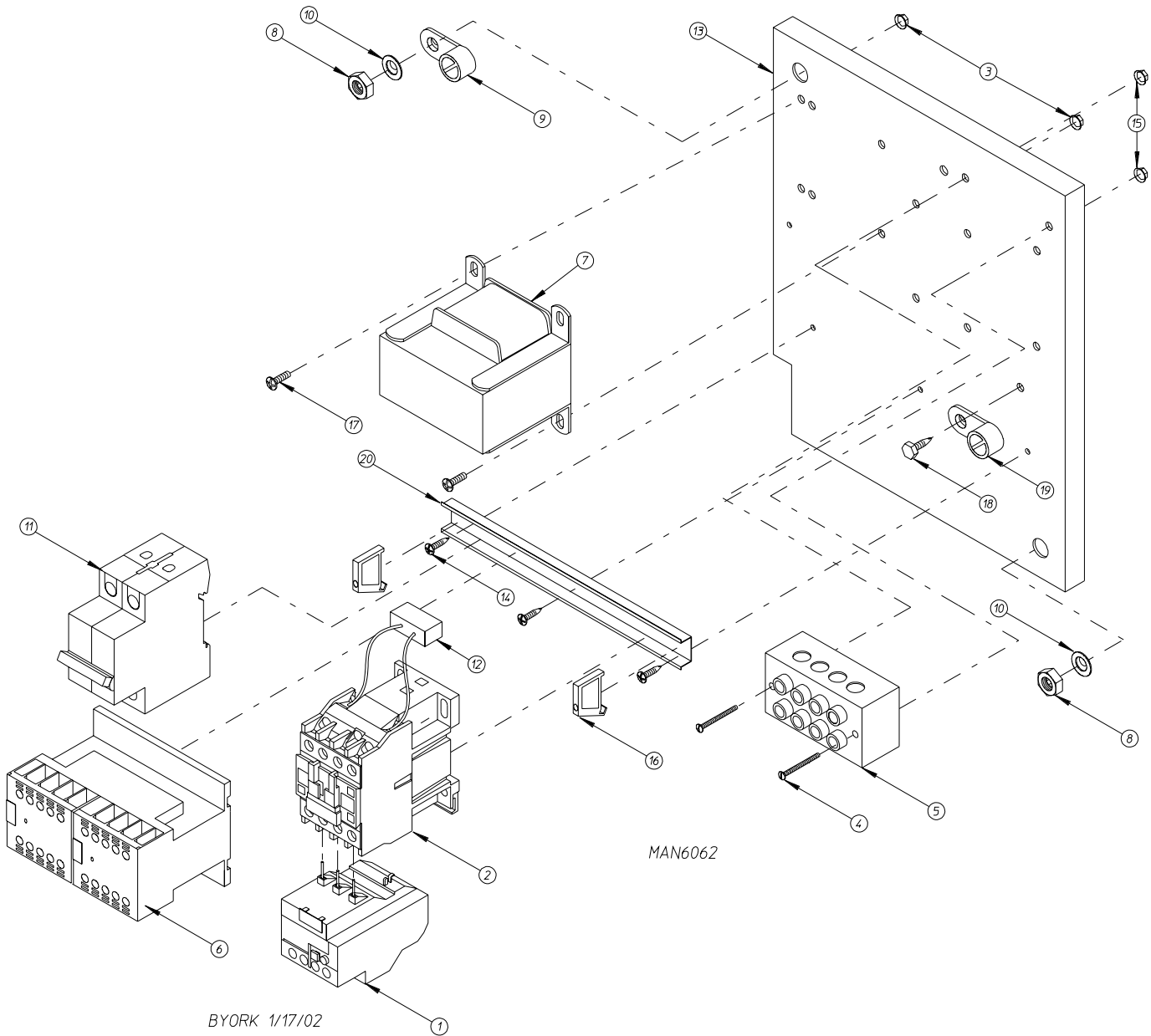

Microprocessor Reversing Contactor Mounting Panel Assembly

For 460-480V Transformers

<u>Illus. No.</u>	<u>Part No.</u>	<u>Qty.</u>	<u>Description</u>
1	132467	1	9-13-amp Overload
2	131393	1	Contactor – 24 VAC
3	151001	2	#8-32 Pal Nut
4	150009	2	#6-32 x 1-1/2" Phillips Round Head Machine Screw
5	120701	1	4-Position Terminal Block
6	132497	1	Reversing Contactor
7	830193	1	460-480V Transformer Assembly
8	152004	2	5/16-18 Hex Nut
9	121012	1	Ground Lug
10	153002	2	5/16" Lock Washer
11	135501	1	2-Pole 1-Amp Circuit Breaker
12	137015	1	Arc Suppressor
13	332346	1	Relay Panel
14	150301	4	#8-18 x 7/16" Phillips Pan Head TEK Screw
15	151000	2	#6-32 Pal Nut
16	120765	2	End Stop / Bracket
17	150108	2	#8-32 x 1/2" Pan Head Machine Screw
18	150297	1	#10 x 1/2" Hex Washer TEK Screw
19	121010	1	L-70 Ground Lug
20	120768	7-3/4"	Din Mounting Rail (sold by the inch)
	830192	1	Relay Panel Wiring ... Not Illustrated
	825267	1	Drive / Blower Motor Contactor Wiring ... Not Illustrated

Sail Switch Assembly

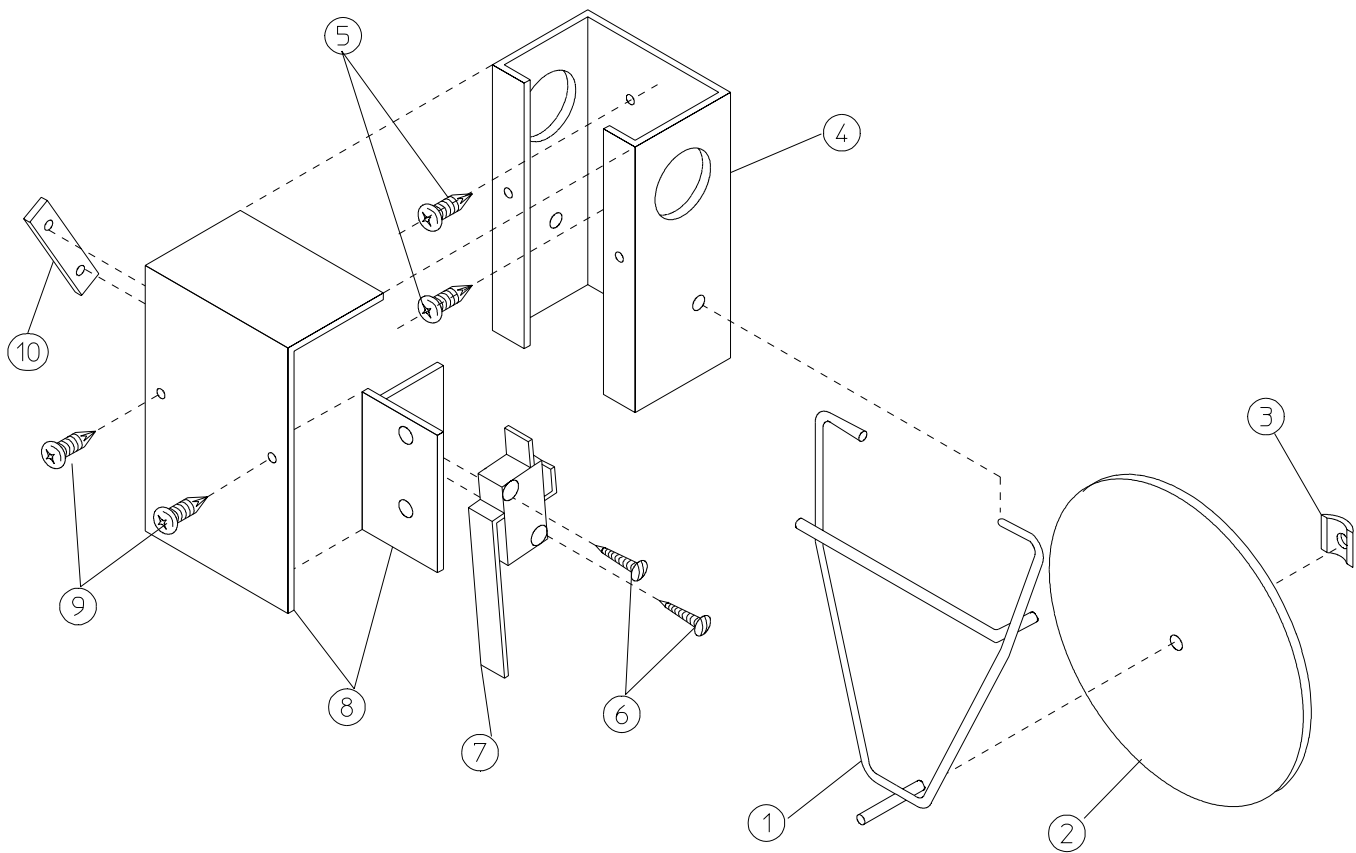

MAN0440

<u>Illus. No.</u>	<u>Part No.</u>	<u>Qty.</u>	<u>Description</u>
1	105500	1	Sail Switch Actuator Rod
2	319202	1	Sail Switch Damper (flat)
3	154002	1	1/8" Push-On Fastener
4	802800	1	Sail Switch Box with Cover and Bracket Only
	802801	1	Sail Switch Box Assembly Complete (includes illus. nos. 1 through 4 and 6 through 10)
5	150309	2	#10-16 x 1/2" Hex Head TEK Crimptite Screw
6	150303	2	#4 x 3/4" Pan Head "A" Machine Screw
7	122200	1	Sail Switch Only
8	802799	1	Sail Switch Box Cover and Bracket Only
9	150309	2	#10-16 x 1/2" Hex Head TEK Crimptite Screw
10	154004	1	Twin Speed Nut

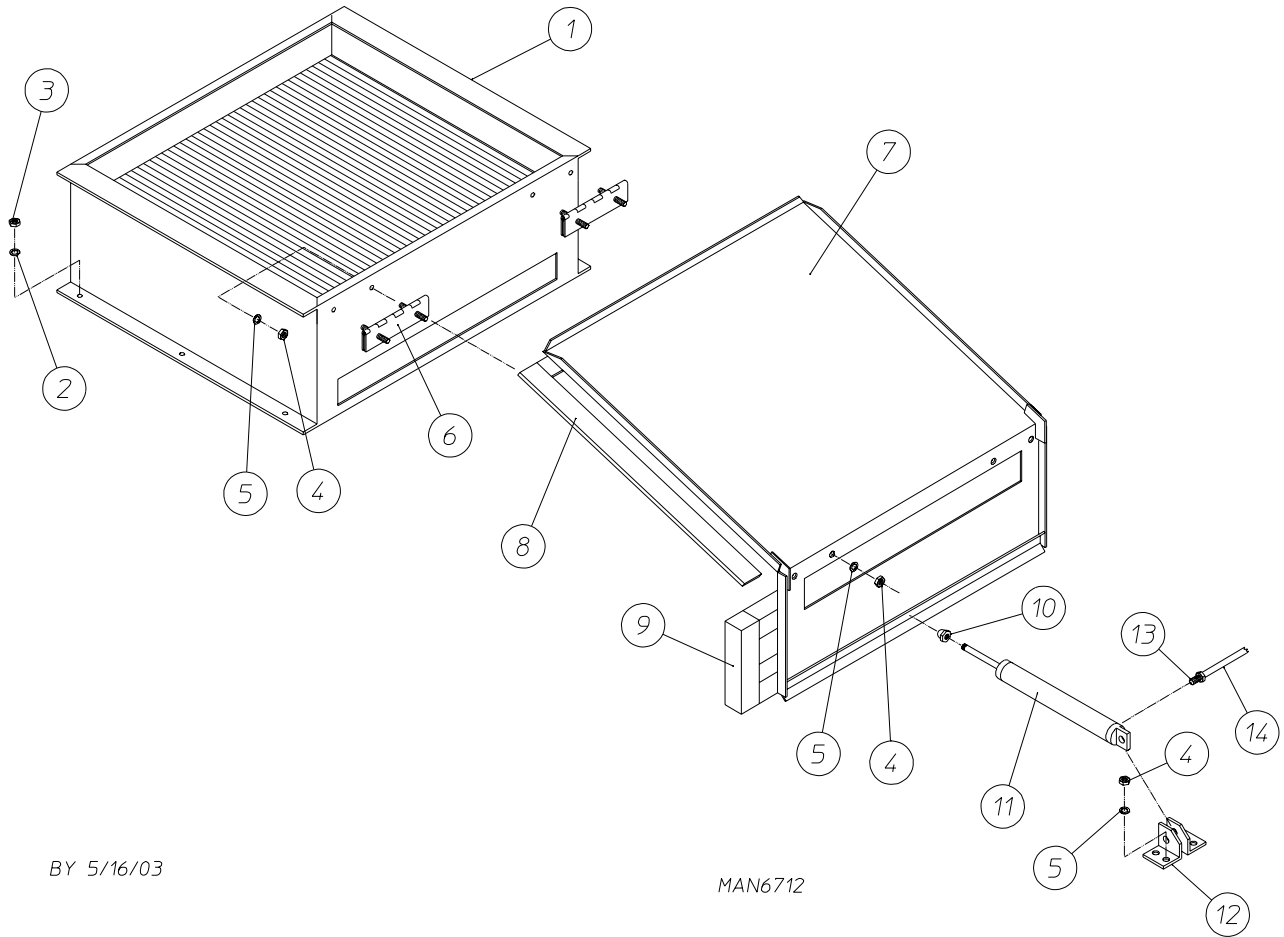

BY 5/16/03

MAN6712

Illus. No.	Part No.	Qty.	Description
1	165092	1	Steam Coil (for models mfd. as of January 2, 2015)
	165078	1	2 Stage Steam Coil (for models mfd. between November 24, 2009 and January 2, 2015)
	165017	1	Steam Coil Only (for models mfd. prior to November 24, 2009)
	165021	1	Steel Steam Coil (option)
2	153002	6	5/16" Lock Washer
3	152004	6	5/16-18 Hex Nut
4	152005	26	3/8-16 Hex Nut
5	153007	26	1/4" Lock Washer
6	820321	2	Steam Damper Hinge Assembly
7	820994	1	Steam Damper Assembly (includes illus. nos. 7, 10, and 11)
8	115995	96	Steam Damper Gasket (sold by the inch)
9	102350	2	Steam Damper Foam (68-1/2" length)
10	151007	1	7/16-20 Stainless Steel Acorn Nut
11	100499	1	1-1/2" Bore x 3" Stroke Piston
12	100500	1	Piston Support Bracket
13	100472	1	1/4" x 1/8" Connector
14	143110	1	1/4" Tubing (sold by the foot)
			(refer to Top Console Assembly on page 34)
—	851053	1	1-1/2" Steam Solenoid Valve Assembly ... Not Illustrated

Top Console Assembly

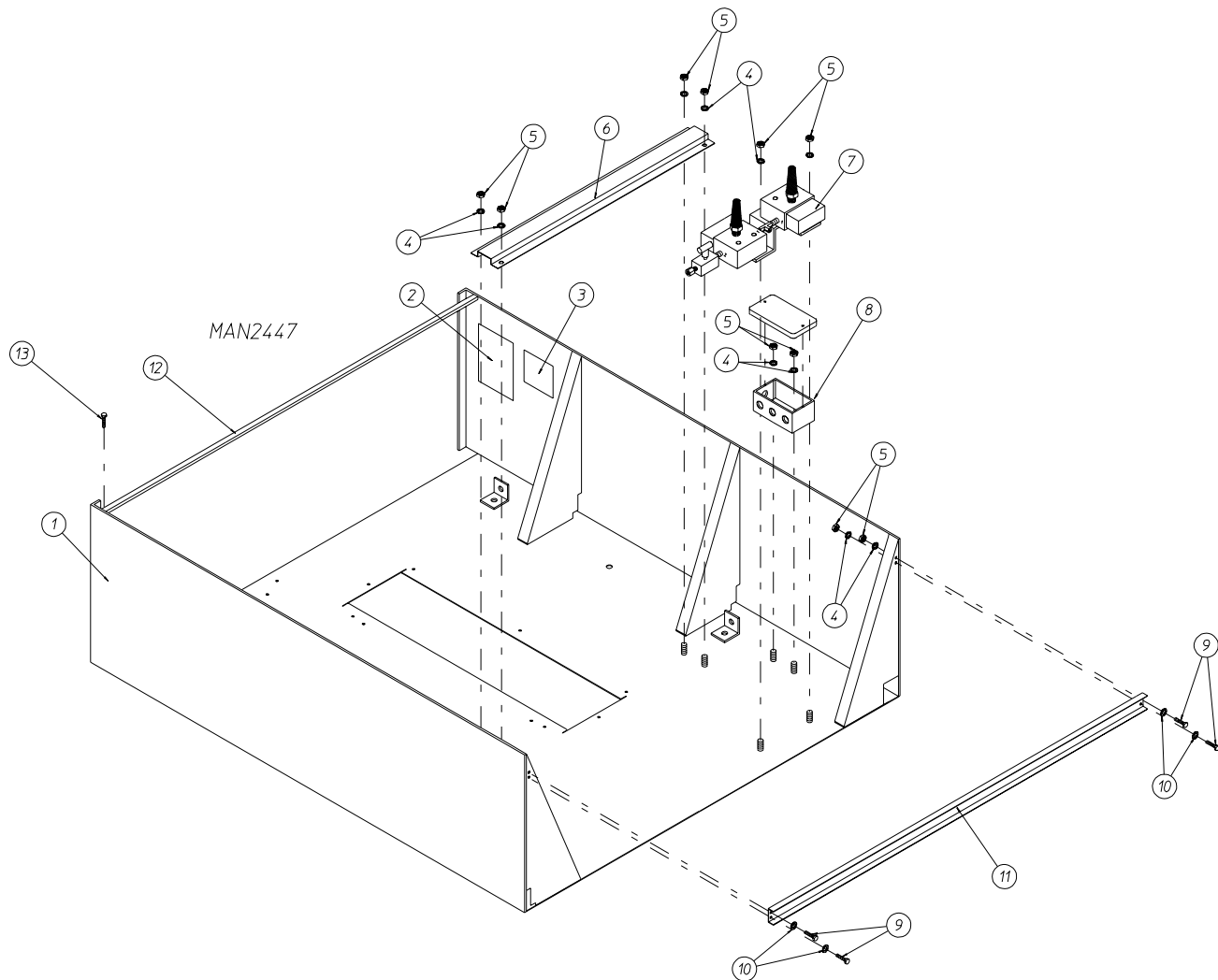

Illus. No.	Part No.	Qty.	Description
1*	821085	1	Top Console Assembly Only (for gas models Only)
	821086	1	Top Console Assembly Only (for steam models Only)
2	114521	1	Phase 7 Non-Coin Program Location Summary Label (for microprocessor models Only)
3	_____	1	Dryer Data Label (not for resale by ADC)
4	153007	12	1/4" Lock Washer
5	152005	12	1/4-20 Hex Nut
6	883864*	1	32" Wire Channel
7	821105	1	Pneumatic Valve Assembly Only (for gas models Only) (refer to Pneumatic Valve Assembly on page 36)
	821104	1	Pneumatic Valve Assembly Only (for steam models Only) (refer to Pneumatic Valve Assembly on page 37)
8	121104	1	2" x 4" Junction Box Only
	121105	1	Junction Box Cover Only
9	150615	4	1/4-20 x 3/4" Bolt
10	153018	4	1/4" Flat Washer
11	883865*	1	Console Gusset Brace
12	883866*	1	Control Door Hinge Channel
13	150300	4	#10-16 x 1/2" Hex Washer TEK Screw

* Specify color when ordering.

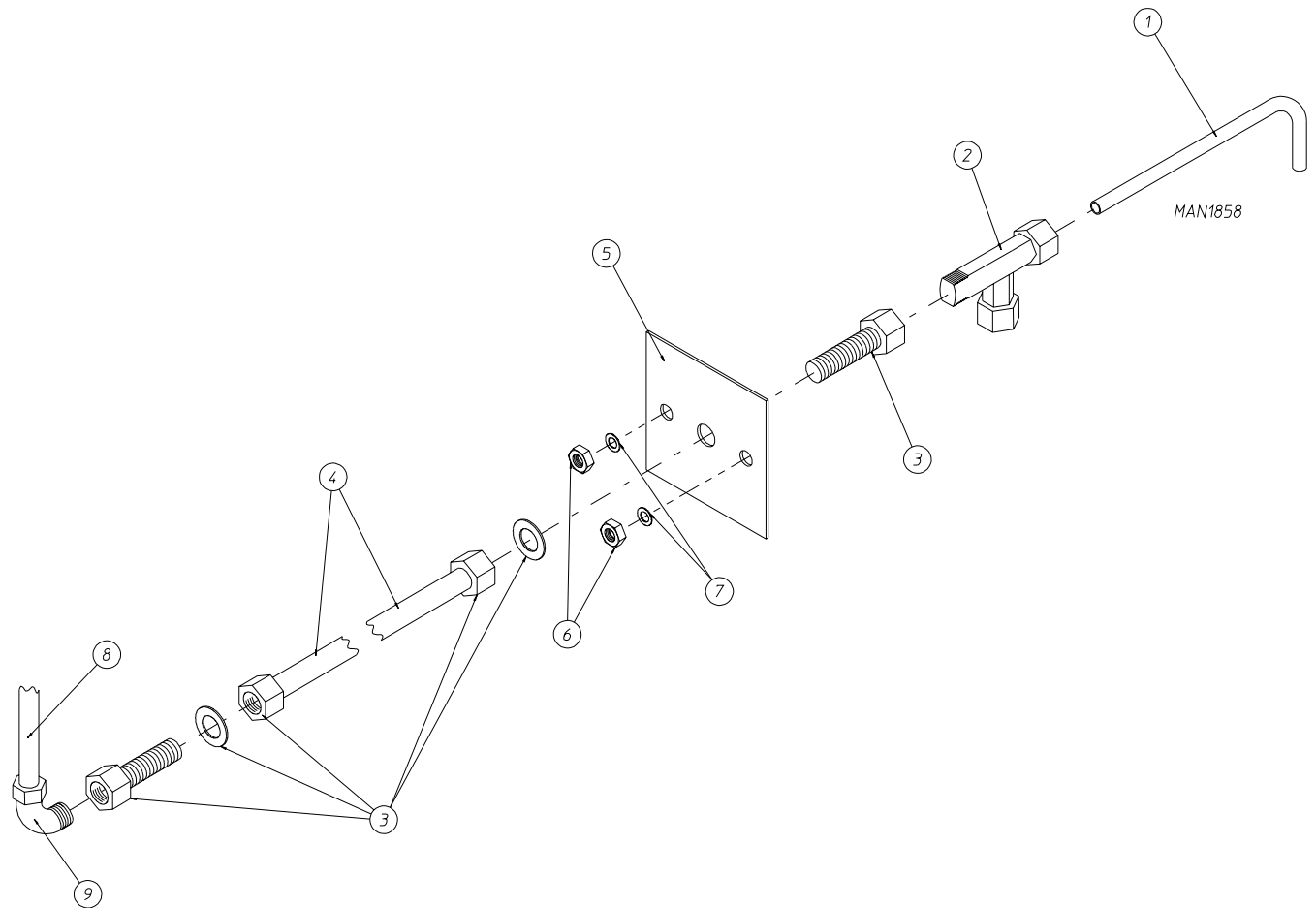

Illus. No.	Part No.	Qty.	Description
1	332700	1	Air Jet Tube Only
2	143287	1	1/4" Compression x 1/8" M.P.T. Male Run Tee
3	143259	2	1/4" Compression x 1/8" F.P.T. Bulkhead Fitting
4	143100	36	1/4" Aluminum Tube (sold by the foot)
5	821081	1	Air Jet Mounting Plate Only (includes illus. nos. 1 through 9)
	332531	1	Air Jet Mounting Plate Only
6	152002	2	1/4-20 Hex Nut
7	153007	2	1/4" Lock Washer
8	143110	6	1/4" Poly-Flo Tubing (sold by the foot)
9	143149	1	1/4" x 1/8" M.P.T. 90° Elbow

Pneumatic Valve Assembly

For Gas Models Only

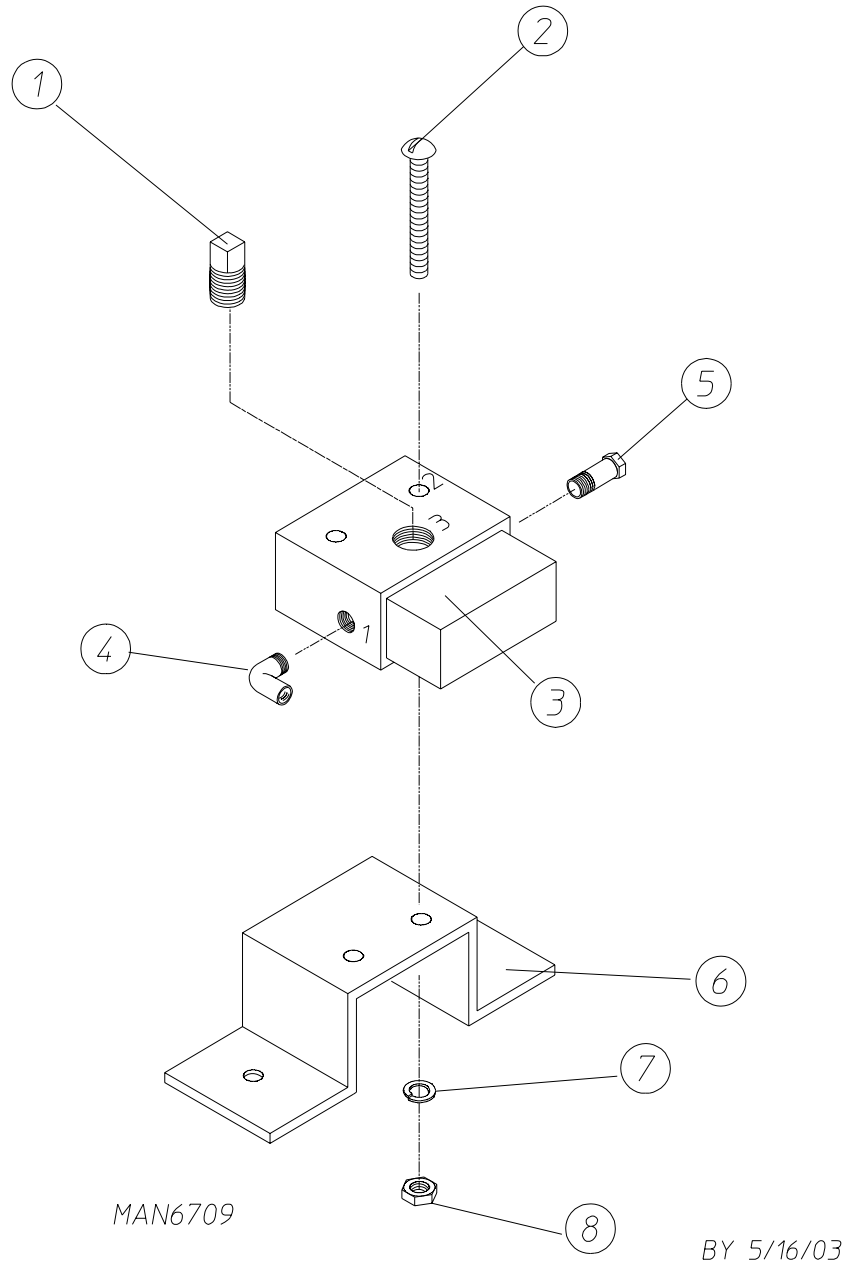

Illus. No.	Part No.	Qty.	Description
1	143250	1	1/8" M.P.T. Brass Plug
2	150002	2	#6-32 x 1" Phillips Round Head Machine Screw
3	100498	1	3-Way Micro Valve Only – 24 VAC
	821105	1	Pneumatic Valve Assembly Complete for Gas Models Only (includes illus. nos. 1 through 8)
4	143149	1	1/4" Poly x 1/8" M.P.T. Elbow
5	100472	1	1/4" x 1/8" Connector
6	330987	1	Micro Valve Support Bracket Only
7	153010	2	#6 Star Washer
8	152000	2	#6-32 Hex Nut

Pneumatic Valve Assembly

For Steam Models Only

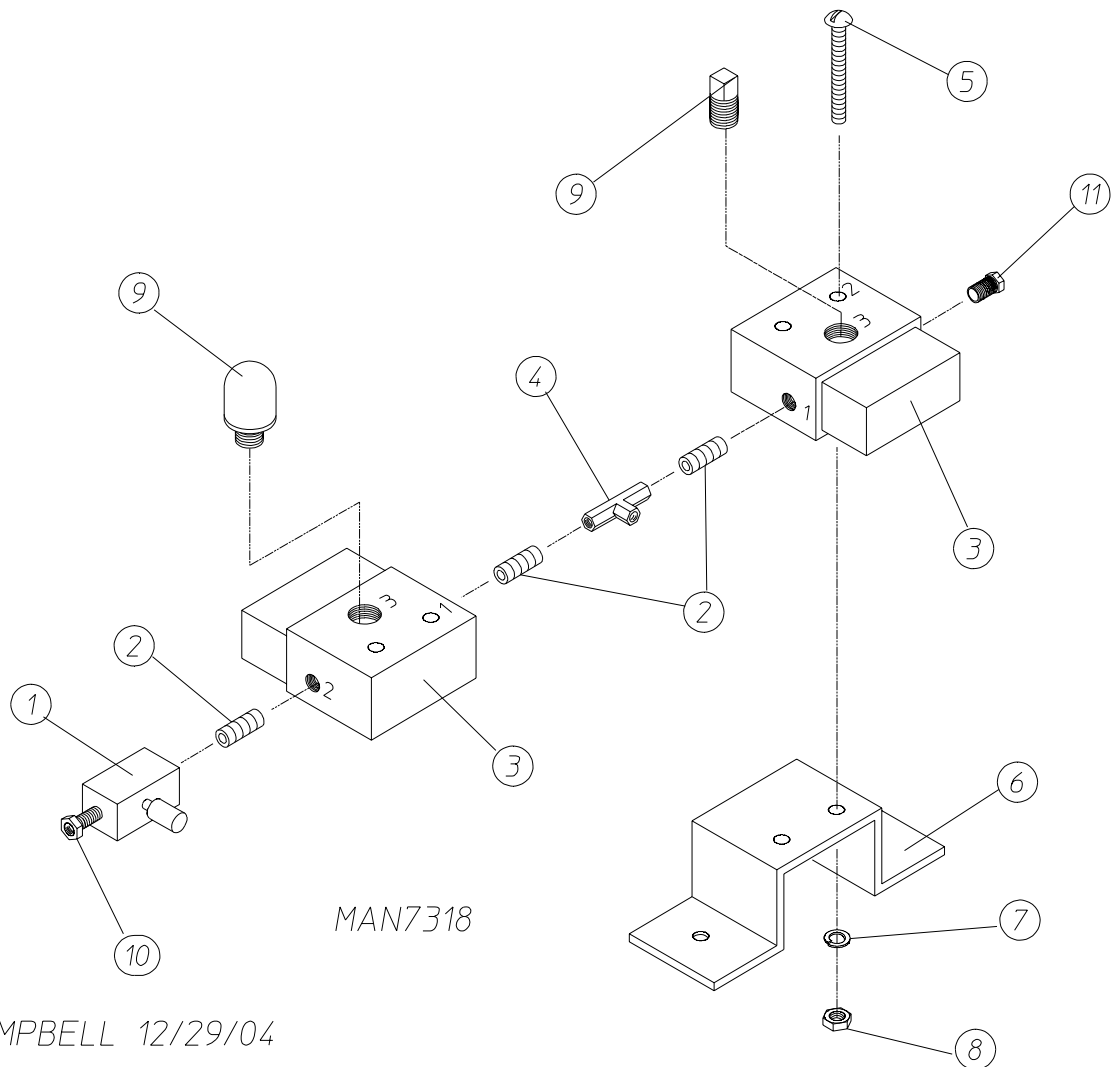

Illus. No.	Part No.	Qty.	Description
1	100496	1	1/8" Needle Valve
2	143238	3	1/8" Close Nipple
3	100498	2	3-Way Micro Valve Only – 24 VAC
	821104	1	Pneumatic Valve Assembly Complete for Steam Models Only (includes illus. nos. 1 through 8)
4	143223	1	1/8" F.P.T. Brass Tee
5	150002	2	#6-32 x 1" Phillips Round Head Machine Screw
6	330987	1	Micro Valve Support Bracket Only
7	153010	2	#6 Star Washer
8	152000	2	#6-32 Hex Nut
9	100520	2	1/8" N.P.T. Silencer (muffler)
10	100472	2	1/4" x 1/8" Connector
11	143250	1	1/8" M.P.T. Brass Plug

S.A.F.E. System Solenoid Assembly

For Models Mfd. as of September 23, 2004

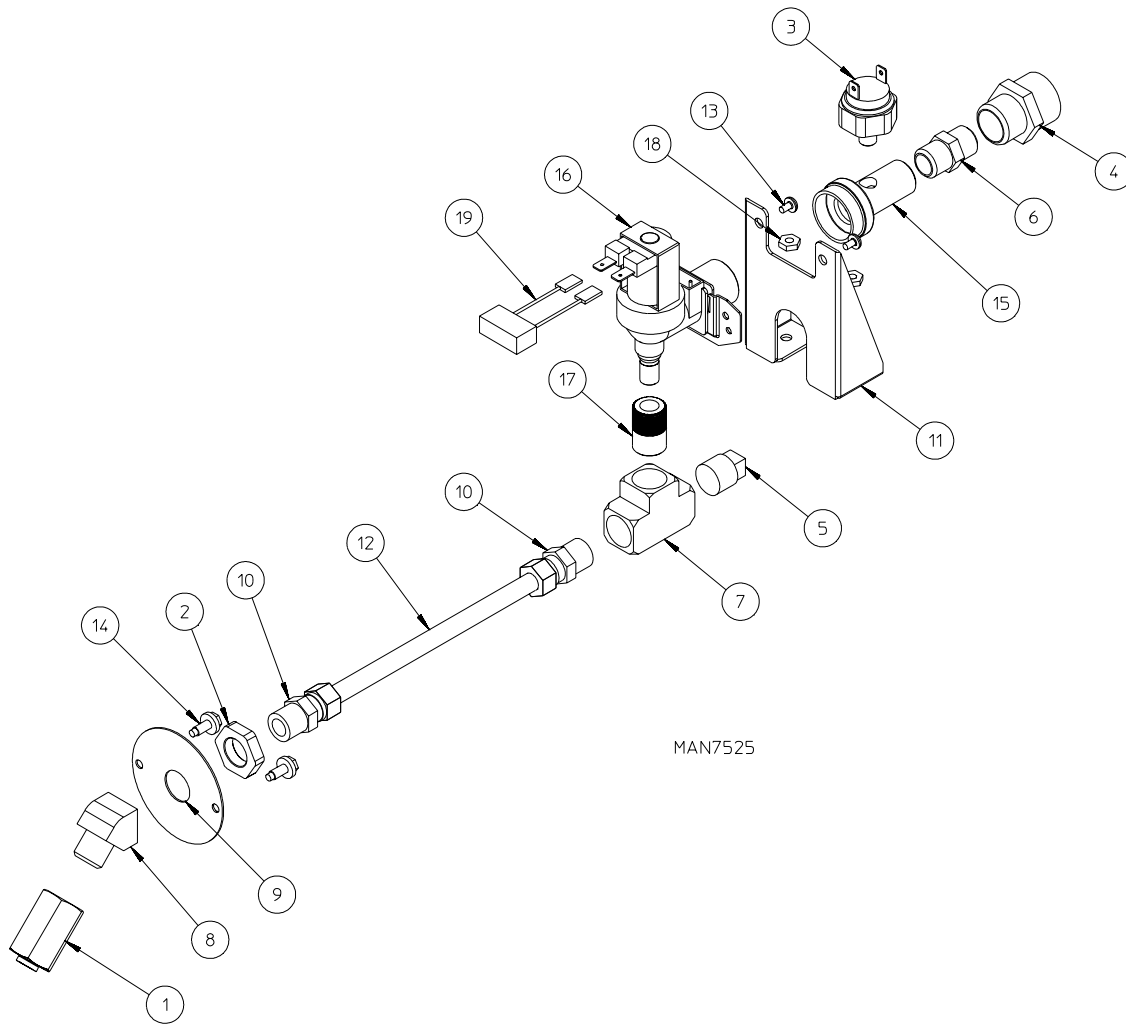

MAN7525

Illus. No.	Part No.	Qty.	Description
1	143581	1	Sensor Activated Fire Extinguishing System 3 GPM 3/8" N.P.T. Spray Nozzle
2	143303	1	3/8" N.P.T. Brass Lock Nut
3	136987	1	Water Jet Pressure Switch
4	143356	1	3/4 NH Male x 3/8" N.P.T. Female Brass Reducing Bushing
5	143251	1	3/8" M.P.T. Brass Plug
6	182579	1	3/8" M.P.T. x 3/8" M.P.T. Brass Hex Nipple
7	143220	1	3/8" F.P.T. Brass Tee
8	143301	1	3/8" Brass 45° Street Elbow
9	311588	1	Sensor Activated Fire Extinguishing System Sprinkler Head Mounting Plate
10	143208	2	3/8" Comp x 3/8" M.P.T. Brass Connector
11	311587	1	Medium Dryer Sensor Activated Fire Extinguishing System Valve Bracket
12	143108	1	20" Stainless Steel Flex Hose with 3/8" Compression
13	154338	2	M4 x 6mm Phillips Head Slotted Machine Screw
14	150309	2	#10-16 x 1/2" Hex Head TEK Crimptite
15	143182	1	3/4" GHT x 1/8" x 3/8" N.P.T. Brass Tee
16	165119	1	Sensor Activated Fire Extinguishing System Water Inlet Valve
17	143183	1	7/16-20 x 3/8" N.P.T. Brass Adapter 2
18	152001	2	#8-32 3/8" Hex Nut
19	824081	1	R.C. Network Assembly

S.A.F.E. Solenoid Assembly

For Models Mfd. between December 3, 2003 - September 13, 2004

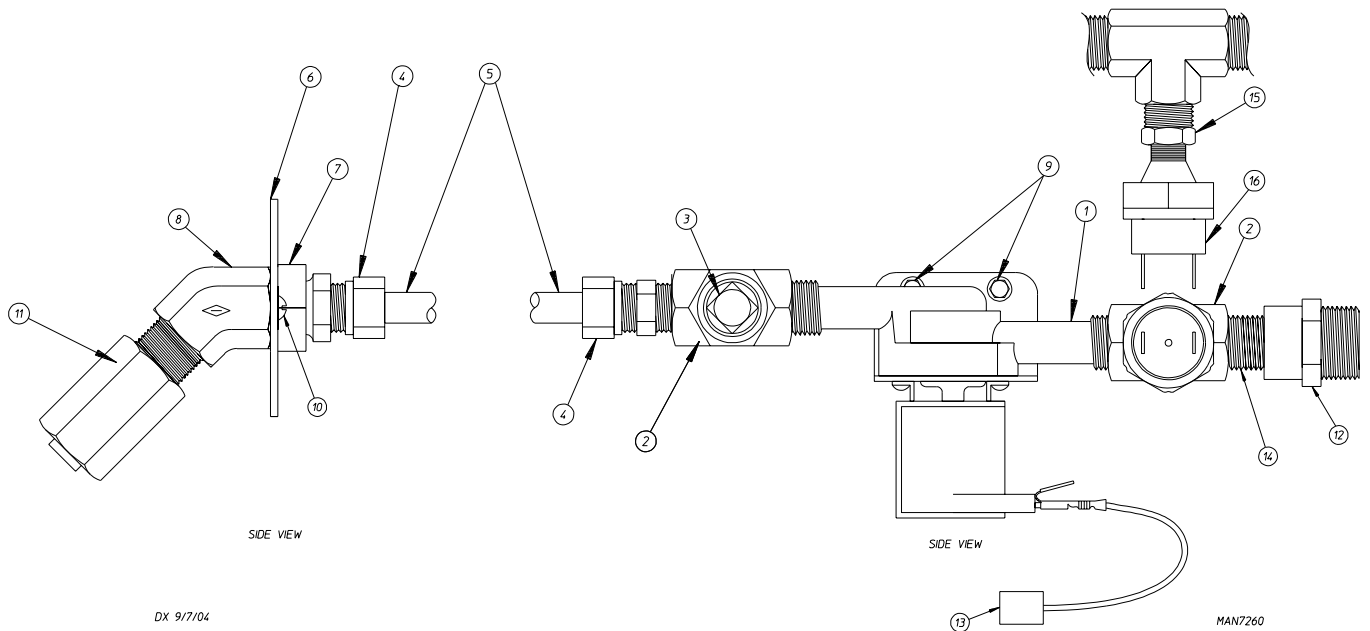

Illus. No.	Part No.	Qty.	Description
1	165114	1	Sensor Activated Fire Extinguishing System Solenoid Valve 24 VAC 50/60 Hz
2	143220	2	3/8" F.P.T. Brass Tee
3	143251	1	3/8" M.P.T. Brass Plug
4	143208	2	3/8" Comp x 3/8" M.P.T. Brass Connect
5	143108	1	20' Long Stainless Steel Flexible Tubing
6	311588	1	Sprinkler Head Mounting Plate
7	143303	1	3/8" N.P.T. Brass Lock Nut
8	143301	1	3/8" Brass 45° Elbow
9	152001	2	#8-32 x OD Hex Nut
10	150430	2	#10 x 1/2" Screw
11	143581	1	3 GPM 3/8" F.P.T. Spray Nozzle
12	143025	1	3/8" N.P.T. Nylon Hose Adaptor
13	824081	1	RC Network Assembly
14	143315	1	Bushing 3/8" x 1/8"
15	136987	1	Pressure Sensor
16	182579	1	3/8" Hex Nipple

S.A.F.E. Solenoid Assembly

For Models Mfd. prior to December 3, 2003

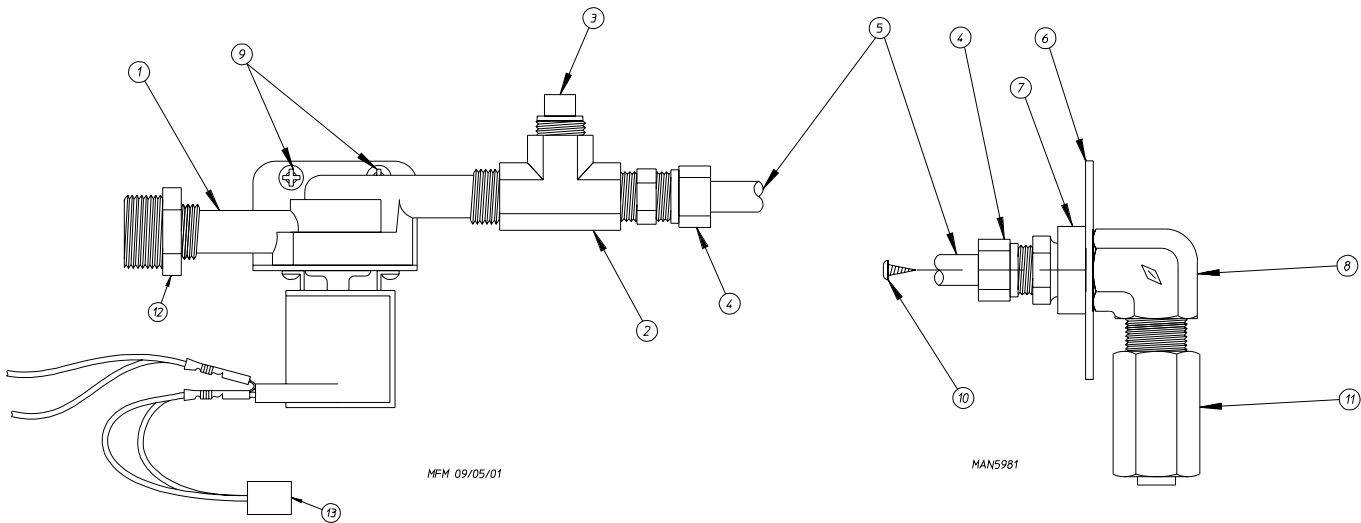

Illus. No.	Part No.	Qty.	Description
1	165114	1	Sensor Activated Fire Extinguishing System Solenoid Water Valve 24V 50/60 Hz
2	143220	1	3/8" F.P.T. Brass Tee
3	143251	1	3/8" M.P.T. Brass Plug
4	143208	2	3/8" Comp x 3/8" M.P.T. Brass Connector
5	143099	6'	3/8" OD x 0.035 Wall Copper Tubing (sold by the foot)
6	311588	1	Sprinkler Head Mounting Plate
7	143303	1	3/8" N.P.T. Brass Lock Nut
8	143155	1	3/8" Brass Elbow 90°
9	150430	2	#10 x 1/2" Self-Drilling Screw
10	150301	2	#8-18 x 7/16" Phillips Pan Head TEK Screw
11	143581	1	3 GPM 3/8" F.P.T. Spray Nozzle
12	142888	1	1/2" to 3/8" Bushing for Sensor Activated Fire Extinguishing System Valve
13	824828	1	Arc Suppressor

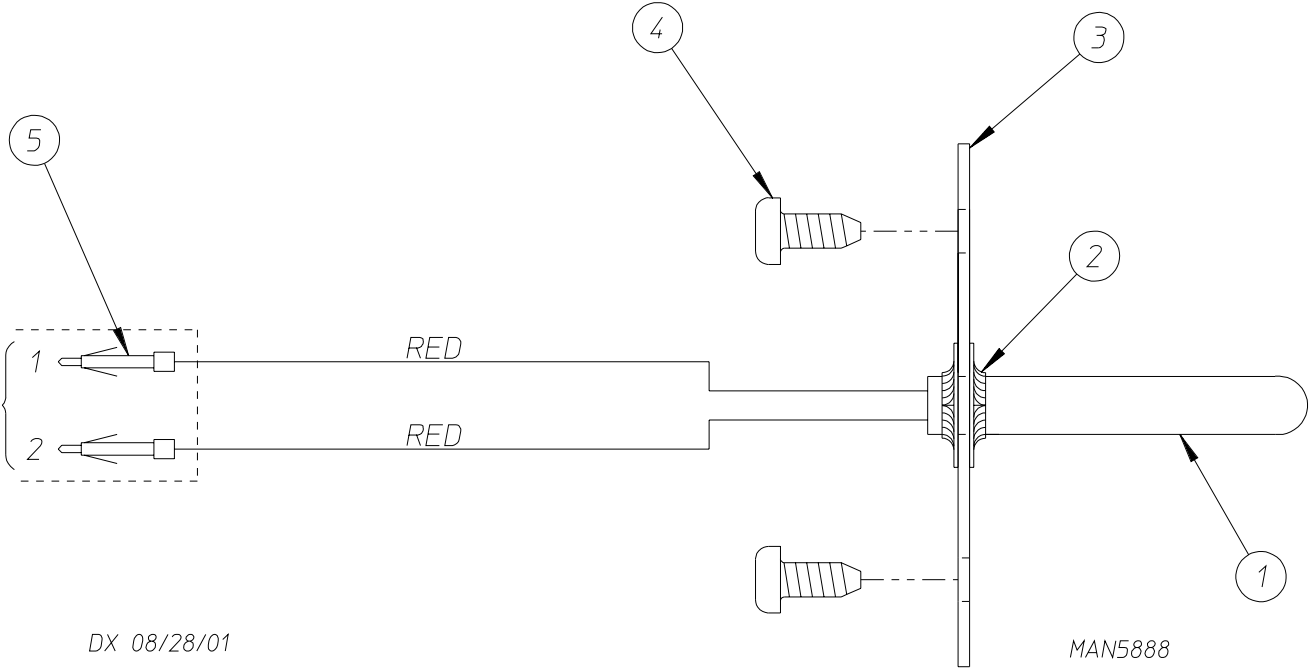

Illus. No.	Part No.	Qty.	Description
1	822752	1	Sensor Activated Fire Extinguishing System Temperature Probe Assembly (includes illus. nos. 1 through 5)
2	154007	2	Push-On Fastener
3	390390	1	Sensor Bracket Only
4	150301	2	#8-18 x 7/16" Phillips Pan Head TEK Screw
5	122647	1	Connector Only
	122700	2	Pins

Back Guard Assemblies

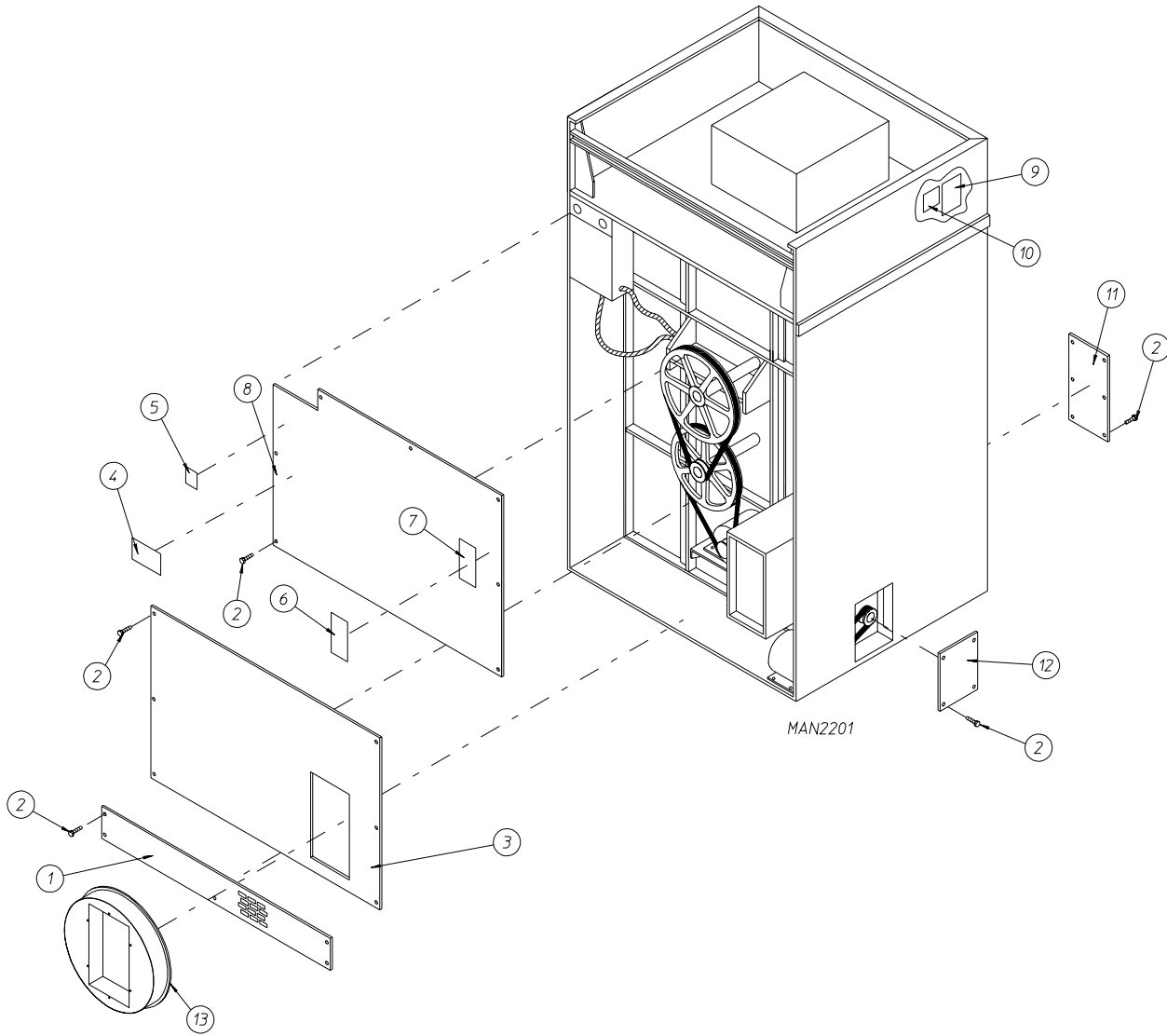

<u>Illus. No.</u>	<u>Part No.</u>	<u>Qty.</u>	<u>Description</u>
1*	883862	1	Bottom Back Guard Only
2	150301	28	#8-18 x 7/16" Phillips Pan Head TEK Screw
3	821096	1	Middle Back Guard Only
4	112014	1	High Voltage Label Only
5	112017	1	"ADC Name, Address, Telephone Number" Label
6	112230	1	"Installation Instructions" Label
7	112519	1	"Routine Maintenance Schedule" Label
8	821095	1	Top Back Guard Only
9	114521	1	"Phase 7 Non-Coin Program Location Summary" Label
10	—	1	Dryer Data Label (not for resale by ADC)
11*	883868	1	Blower Housing Front Access Panel
12*	883869	1	Side Access Panel
13	821092	1	Square Duct to Round Duct Transition Piece Assembly
	117505	**	Aluminum Duct Tape ... Not Illustrated

* Specify color when ordering.
 ** As required.

DSI Burner Orifice Specification*				
Qty.	Natural Gas		Propane Gas	
	D.M.S.	Part No.	D.M.S.	Part No.
4	#2	140839	#29	140820

* Consult factory for elevations over 2,000 feet.

DSI Burner Assembly Specifications		
Btu/hr Rating	Natural Gas Part No.	Propane Gas Part No.
550,000	835037	821960
NOTES: 1. Burner assemblies do not include burner orifices. They must be ordered. 2. When ordering burner assembly specify the model number and serial number of the dryer.		

DSI Propane Kit Specification*
Kit Part No. 880978

* Consult factory for elevations over 2,000 feet.

Step Down Transformer Application Listing

Step Down Transformer Application Listing (Reversing Relay Box)			
HEAT	VOLTAGE	WIRE SERVICE	TRANSFORMER PART NUMBER
			MICROPROCESSOR MODELS
GAS AND STEAM	380	3 or 4	132059
	416	3 or 4	132062
	440	3 or 4	132056
	460 / 480	3 or 4	132053
	575	3	132050

NOTE: For voltages of 380 or above.

<u>Part No.</u>	<u>Description</u>
112098	“Check Rotation” Label
114001	“CAUTION – Exhaust Lint Screen” Label
114006	“WARNING – Fire Hazards” Label
120102	3/8” Straight (BX) Connector
120111	1/2” Liquidtite 45° Connector
120400	3/8” Red Jacket (BX) Insulator
120500	3/8” Jiffy Clip (BX retainer clip)
120600	3/8” Greenfield (BX)
120800	1/4” In-Line Connector
120802	Red Butt Connector
120902	#74B Wire Nut
120903	Crimp-On Wire Nut
120904	Red Wire Nut
121499	5-1/2” Harness Tie
121500	8” Harness Tie
122804	15” Manometer (water column test gauge)
404500	Almond Brush-In-Cap Bottle Touch-Up Paint
404502	White Brush-In-Cap Bottle Touch-Up Paint
404506	Beige Brush-In-Cap Bottle Touch-Up Paint
404507	Cornflower Blue Brush-In-Cap Bottle Touch-Up Paint

