



AD-24 Parts Manual

24 VAC Phase 5

1992 thru 1996

American Dryer Corporation
88 Currant Road
Fall River, MA 02720-4781
Telephone: (508) 678-9000 / Fax: (508) 678-9447
E-mail: techsupport@amdry.com

www.amdry.com

Retain This Manual In A Safe Place For Future Reference

American Dryer Corporation products embody advanced concepts in engineering, design, and safety. If this product is properly maintained, it will provide many years of safe, efficient, and trouble free operation.

ONLY qualified technicians should service this equipment.

OBSERVE ALL SAFETY PRECAUTIONS displayed on the equipment or specified in the installation manual included with the dryer.

The following “**FOR YOUR SAFETY**” caution must be posted near the dryer in a prominent location.

FOR YOUR SAFETY

Do not store or use gasoline or other flammable vapors and liquids in the vicinity of this or any other appliance.

POUR VOTRE SÉCURITÉ

Ne pas entreposer ni utiliser d'essence ni d'autres vapeurs ou liquides inflammables à proximité de cet appareil ou de tout autre appareil.

We have tried to make this manual as complete as possible and hope you will find it useful. ADC reserves the right to make changes from time to time, without notice or obligation, in prices, specifications, colors, and material, and to change or discontinue models.

Important

For your convenience, log the following information:

DATE OF PURCHASE _____ MODEL NO. **AD-24**
RESELLER'S NAME _____
Serial Number(s) _____

Replacement parts can be obtained from your reseller or the ADC factory. When ordering replacement parts from the factory, you can FAX your order to ADC at (508) 678-9447 or telephone your order directly to the ADC Parts Department at (508) 678-9000. Please specify the dryer model number and serial number in addition to the description and part number, so that your order is processed accurately and promptly.

The illustrations on the following pages may not depict your particular dryer exactly. The illustrations are a composite of the various dryer models. Be sure to check the descriptions of the parts thoroughly before ordering.

“IMPORTANT NOTE TO PURCHASER”

Information must be obtained from your local gas supplier on the instructions to be followed if the user smells gas. These instructions must be posted in a prominent location near the dryer.

Table of Contents

High Security Control Door Assembly	4
Phase 5 Coin Microprocessor Control Panel Assembly for models mfd. as of April 29, 1994	5
Phase 5 Coin Microprocessor Control Panel Assembly for models mfd. prior to April 29, 1994	6
Phase 5 Non-Coin Microprocessor Control Panel Assembly	7
Phase 5 Microprocessor Control Box Assembly for Coin and Non-Coin Models	8
Coin Vault Assembly	9
Slide Meter Case Assembly for models mfd. as of January 13, 1995	10
Slide Meter Case Assembly for models mfd. prior to January 13, 1995	11
Main Door Assembly	12
Main Door Switch Assembly	13
Front Panel Assembly	14
Tumbler / Support Assemblies	15
Right Hand Hinged Lint Door Assembly for models mfd. as of October 24, 1994	16
Lint Door / Lint Drawer Assembly for models mfd. between May 14, 1994 and October 24, 1994	17
Drop Lint Door Assembly for models mfd. prior to May 14, 1994	18
Lint Trap Assembly	19
Sensor Bracket Assemblies	20
Tumbler Bearing Assembly	22
Idler Bearing Assembly	24
Totally Enclosed, Fan-Cooled Motor Mount Assembly	25
Direct Spark Ignition Burner Assembly	26
Electric Oven Assembly	28
Sail Switch / Hi-Limit Assemblies	30
Single-Phase Motor, Electric Relay Panel Assembly	31
Slide Meter Control Box Assembly for models mfd. as of January 13, 1995	32
Slide Meter Control Box Assembly for models mfd. prior to January 13, 1995	33
Outer Top / Back Guard Assembly	34
Electric Oven Component Application Chart	35
Microprocessor Coin Acceptor Listing	36
Additional Parts Available	37

High Security Control Door Assembly

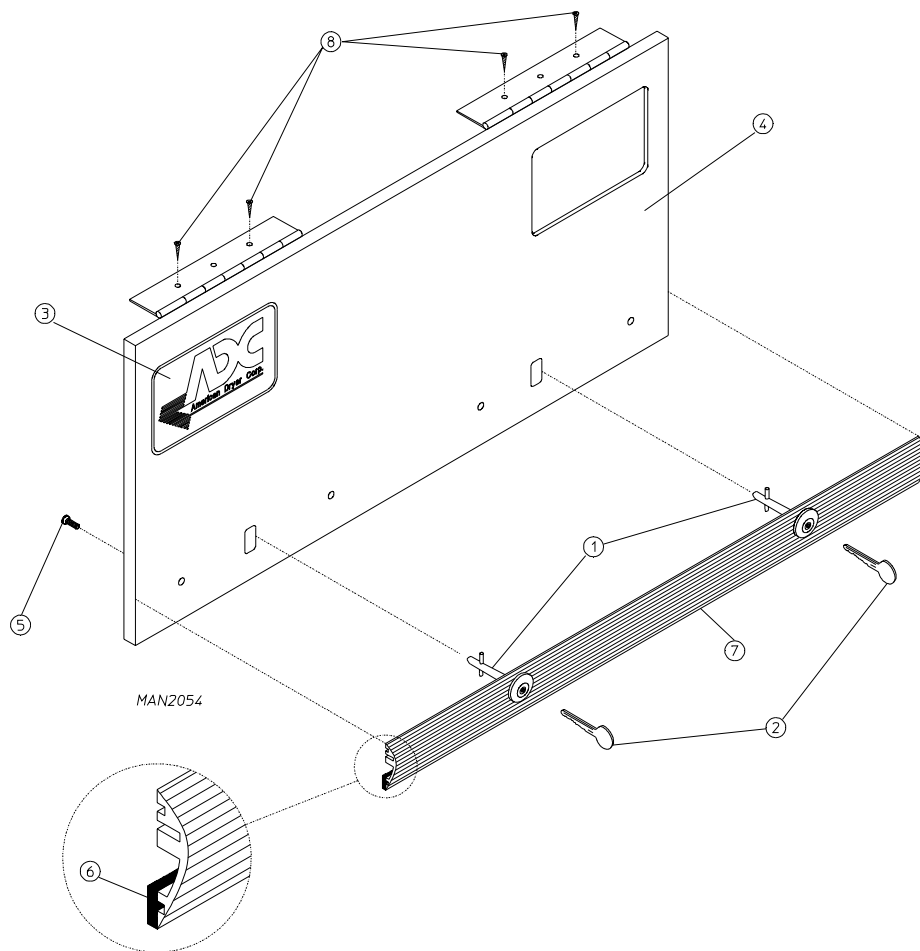

Illus. No.	Part No.	Qty.	Description
1	160040	2	High Security Control Door Lock
2	160140	2	Key ONLY (key number XX4451)
3	881053	1	ADC Logo with Tape
	870011	1	Logo Double Sided Tape Kit
4	802506	1	High Security Control Door Assembly Complete (for models mfd. as of July 17, 2000) (includes illus. nos. 4 through 7)
	800028*	1	High Security Control Door Assembly Complete (for models mfd. prior to July 17, 2000) (includes illus. nos. 4 through 7)
5	150201	4	#10-32 x 1/4" Phillips Pan Head Taptite Screw
6	117603	3	Suppressor Tape / Gasket (sold by the foot) (for models mfd. as of February 6, 1995)
	102307	3	Trim Bumper Gasket (sold by the foot) (for models mfd. prior to February 6, 1995)
7	802514	1	Top Trim Strip with 2 Lock Holes (for models mfd. as of July 17, 2000)
	180206	1	Top Trim Strip with 2 Lock Holes (for models mfd. prior to July 17, 2000)
8	150420	4	#10-16 x 5/8" Tamperproof TEK Screw
	150421	1	Tamperproof Screw Hand Driver

* Specify color when ordering.

Phase 5 Coin Microprocessor Control Panel Assembly

For models mfd. as of April 29, 1994

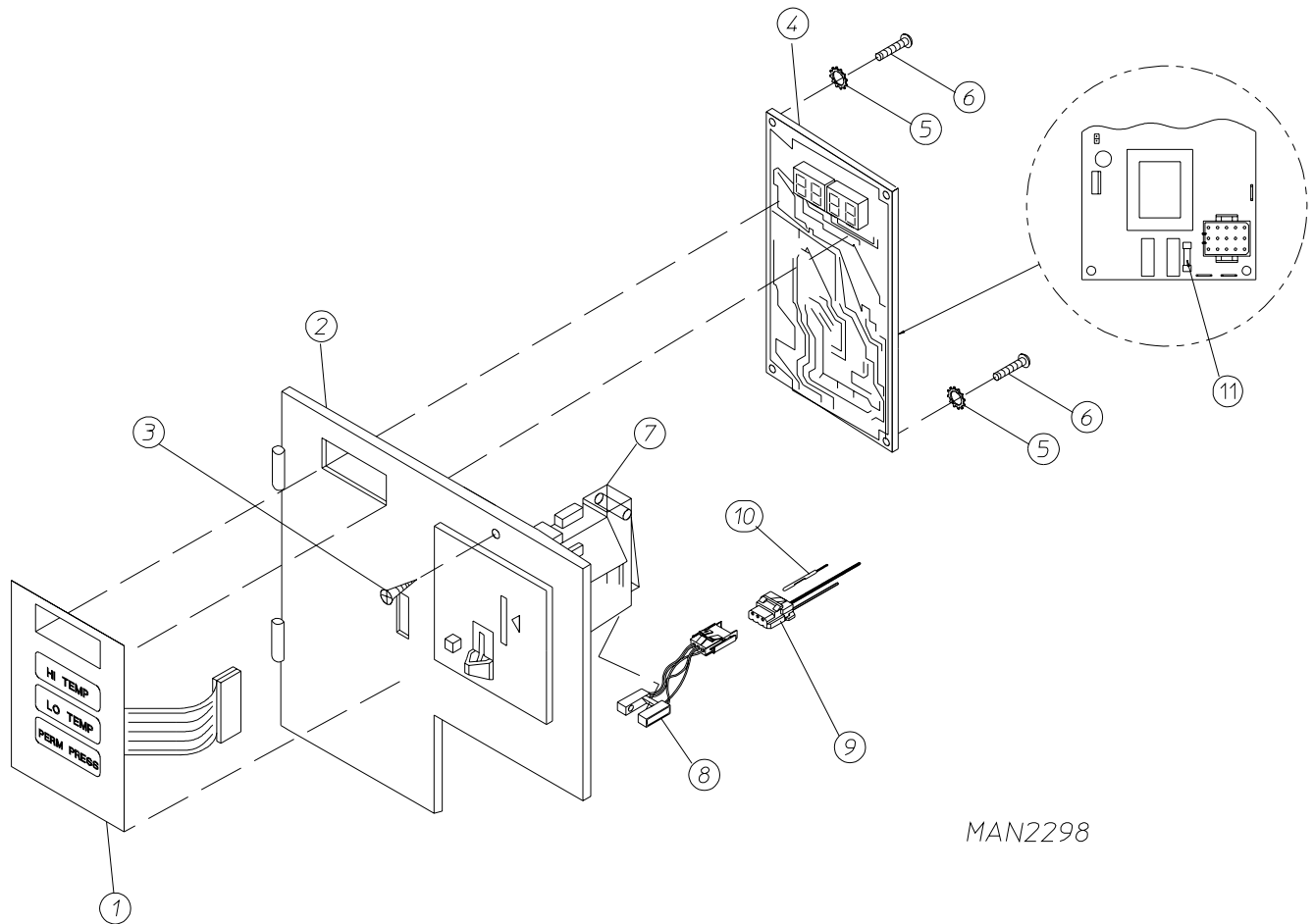

MAN2298

Illus. No.	Part No.	Qty.	Description
1	112526	1	Coin Keypad Label Assembly
2	880959	1	Phase 5 Coin Microprocessor Control Panel Assembly (includes illus. nos. 1, 2, 4, 5, 6, and 11)
	880958	1	Coin Control Panel ONLY
3	150415	1	#10-16 x 1/2" Phillips Round Head CrimpTite Screw
4	137213	1	Phase 5 Coin Controller
	824998	1	Phase 5 Battery Clip
5	153010	2	#6 Star Washer
6	153005	2	#6-32 x 1/4" Phillips Round Head Machine Screw
7	—	1	Microprocessor Coin Acceptor with Optical Switch (refer to Microprocessor Coin Acceptor Listing on page 36)
8	137056	1	Optical Switch
9	137023	1	Optical Switch Connector
10	137021	3	Microprocessor Socket
—	880772	1	Single Coin Optic Switch Harness
—	824080	1	Dual Coin Optic Switch Harness
—	122800	1	Microprocessor (female) Pin Extraction Tool
11	136048	1	1/8-Amp (Slo-Blo) Fuse

IMPORTANT: Check label on computer chip to verify correct part number for microprocessor controller.

Phase 5 Coin Microprocessor Control Panel Assembly

For models mfd. prior to April 29, 1994

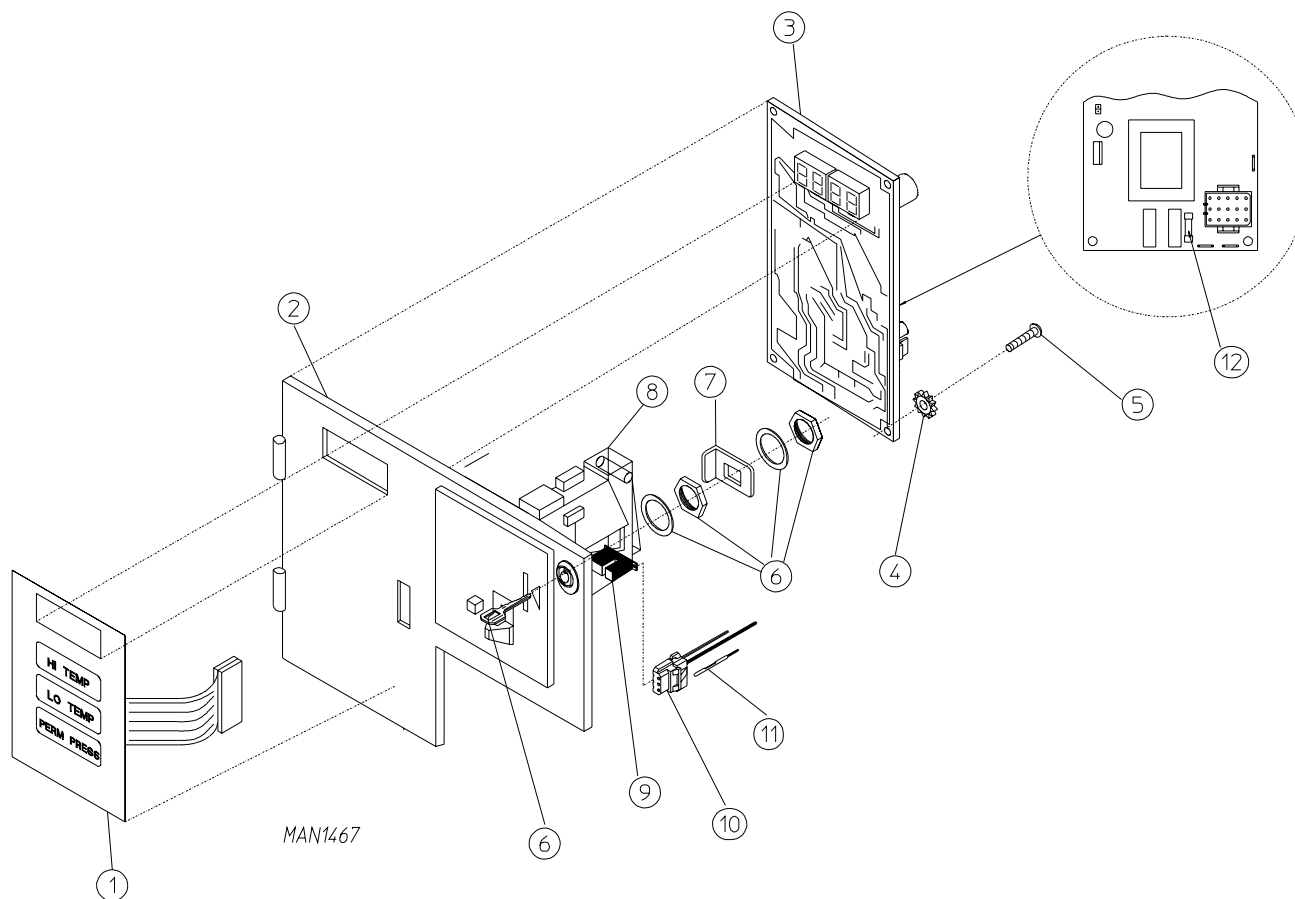

Illus. No.	Part No.	Qty.	Description
1	112526	1	Coin Keypad Label Assembly
2	850453	1	Phase 5 Coin Microprocessor Control Panel Assembly (includes illus. nos. 1 through 5 and 12)
	850454	1	Coin Control Panel ONLY
3	137213	1	Phase 5 Coin Controller
	824998	1	Phase 5 Battery Clip
4	153010	2	#6 Star Washer
5	153005	2	#6-32 x 1/4" Phillips Round Head Machine Screw
6	160015	1	MK-100 High Security Lock Assembly with Key
	160104	1	MK-100 Key
7	160012	1	Computer Panel Lock Cam
8	—	1	Microprocessor Coin Acceptor with Optical Switch (refer to Microprocessor Coin Acceptor Listing on page 36)
	125100	1	25¢ Optical Coin Acceptor
9	137056	1*	Optical Switch
10	137023	1*	Optical Switch Connector
11	137021	3*	Microprocessor Socket
—	880772	1	Single Coin Optic Switch Harness
—	824080	1	Dual Coin Optic Switch Harness
—	122800	1	Microprocessor (female) Pin Extraction Tool
12	136048	1	1/8-Amp (Slo-Blo) Fuse

* For dual coin models, double the quantity.

IMPORTANT: Check label on computer chip to verify correct part number for microprocessor controller.

Phase 5 Non-Coin Microprocessor Control Panel Assembly

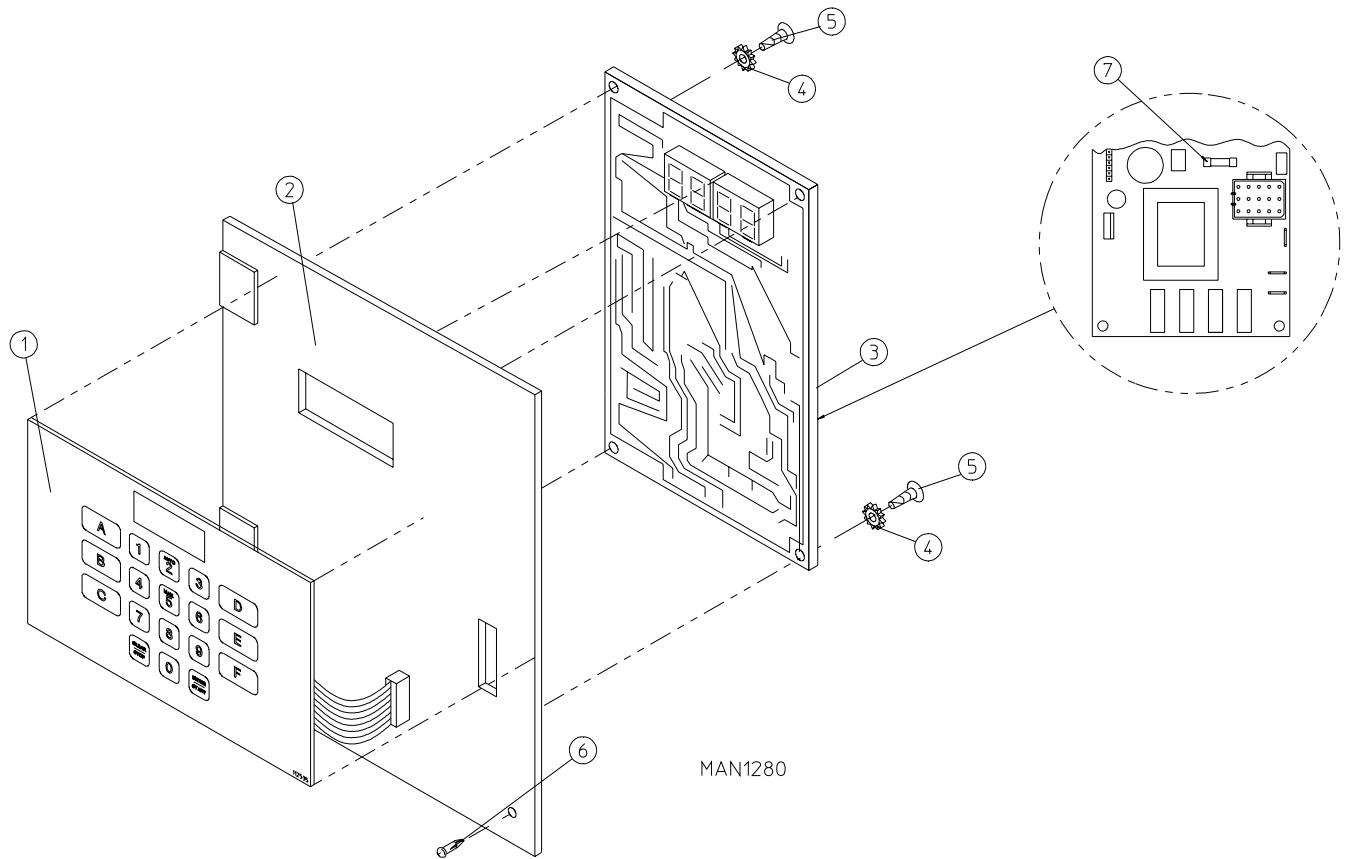

Illus. No.	Part No.	Qty.	Description
1	112535	1	Non-Coin English Keypad Label Assembly
	112276	1	Non-Coin Stick-On Labels (English Only) ... Not Illustrated
	112275	1	Non-Coin Stick-On Labels (Spanish, Italian, and Hebrew) ... Not Illustrated
	112277	1	3-Language Non-Coin Stick-On Labels (English, Spanish, and Hebrew) ... Not Illustrated
	112278	1	5-Language Non-Coin Stick-On Labels (Italian, Dutch, French, German, and Chinese) ... Not Illustrated
2	801225	1	Phase 5 Microprocessor Control Panel ONLY
	824443	1	Phase 5 Non-Coin Non-Reversing Microprocessor Control Panel Assembly Complete (includes illus. nos. 1 through 7)
3	137222	1	Phase 5 Non-Coin Non-Reversing Controller
	824998	1	Phase 5 Battery Clip
4	153010	2	#6 Star Washer
5	150005	2	#6-32 x 1/4" Phillips Round Head Machine Screw
6	150415	1	#10-16 x 1/2" Phillips Round Head Crimp-tite Screw (for models mfd. as of March 1, 1994)
	160005	1	Spring Turn Latch (2-piece) (for models mfd. prior to March 1, 1994)
7	136048	1	1/8-Amp (Slo-Blo) Fuse

IMPORTANT: Check label on computer chip to verify correct part number for microprocessor controller.

Phase 5 Microprocessor Control Box Assembly

For Coin and Non-Coin Models

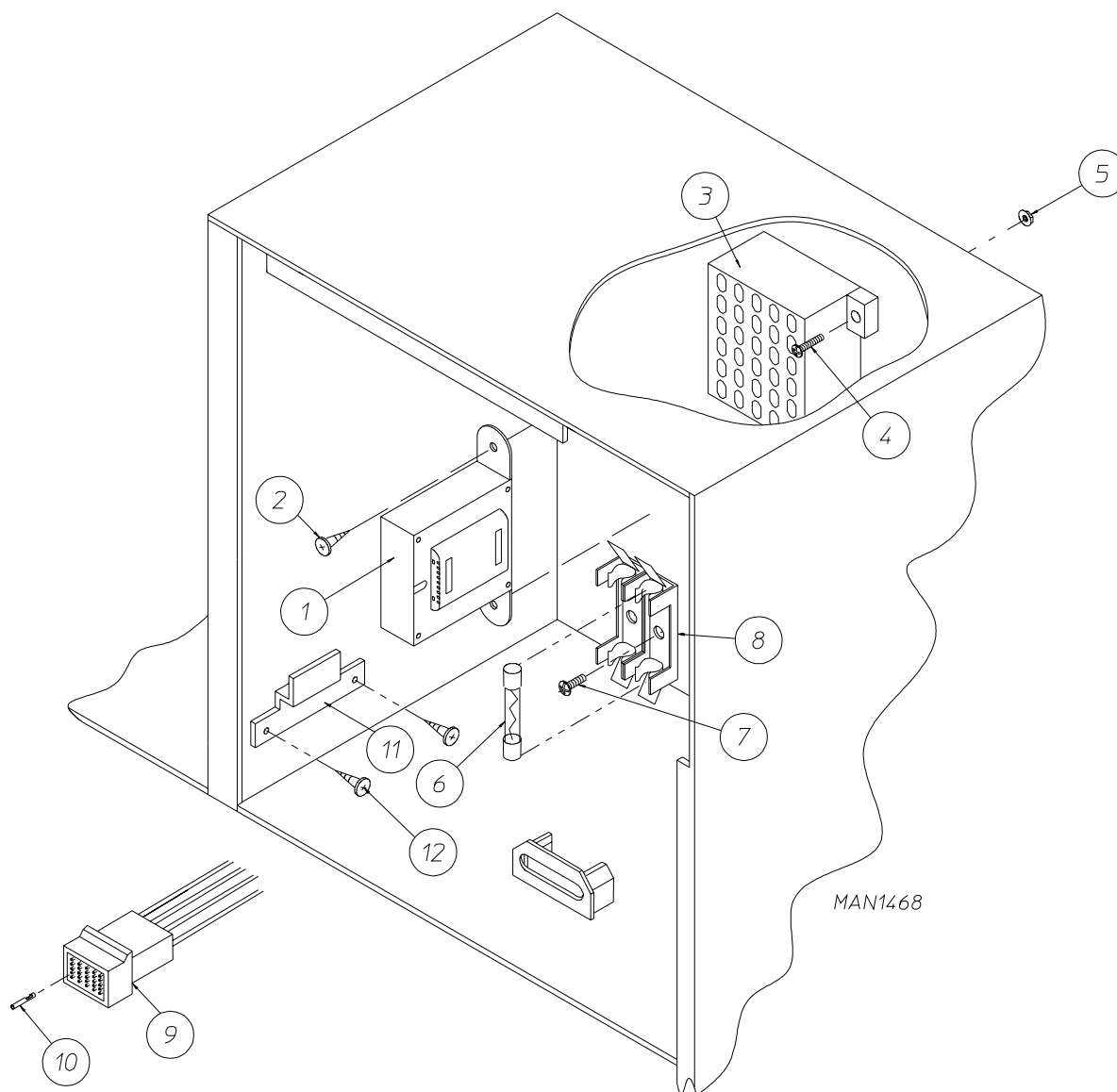

Illus. No.	Part No.	Qty.	Description
1	141403	1	24 VAC Transformer
2	150301	2	#8-18 x 7/16" Phillips Pan Head TEK Screw
3	120715	1	30-Position Terminal Block
4	150002	2	#6-32 x 1" Round Head Machine Screw
5	151000	2	#6-32 Pal Nut
6	136057	*	1/2-Amp (Slo-Blo) Fuse
7	150301	*	#8-18 x 7/16" Phillips Pan Head TEK Screw
8	136008	*	Fuse Block / Strip
9	122641	1	15-Pin Microprocessor Connector
10	122706	*	Socket Terminal
11	305542	1	Battery Bracket
12	150301	2	#8-18 x 7/16" Phillips Pan Head TEK Screw

* As required.

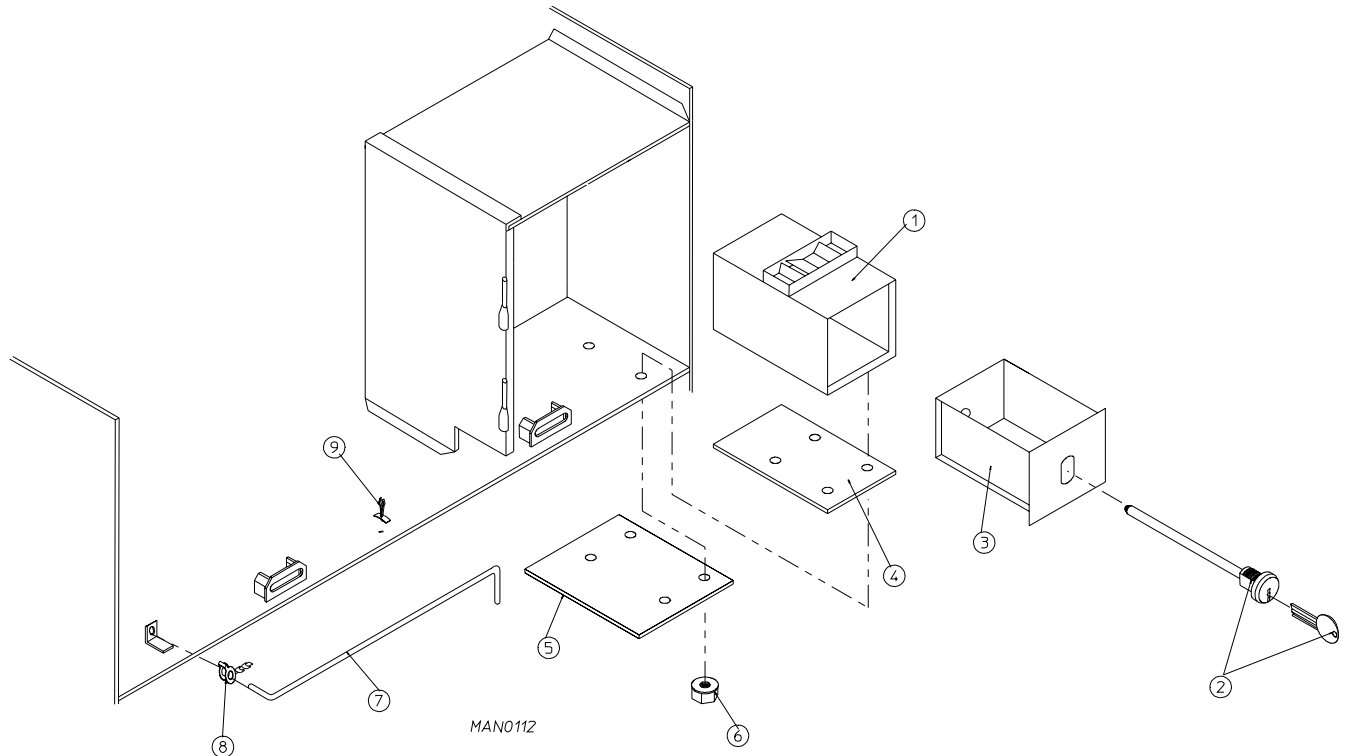

MAN0112

Illus. No.	Part No.	Qty.	Description
1	802146	1	Security Coin Vault Assembly Complete (includes illus. nos. 1 and 3)
	802139	1	High Security Coin Vault ONLY
2	160027	1	High Security Lock with Key (each keyed different)
	160127*	1	Key ONLY for High Security Lock
	160022	1	High Security Screw Lock with Key
	160113*	1	Key ONLY for High Security Screw Lock
3	802138	1	High Security Coin Box Assembly with Lock (includes illus. nos. 2 and 3)
	802147	1	High Security Coin Box ONLY
4	316048	1	Coin Vault Spacer Plate
5	309250	1	Coin Vault Slot Cover
6	152014	4	1/4-20 Free Spin Wash Nut
7	102502	1	Control Door Support Rod
8	102601	1	Control Door Rod Retainer Clip
9	102600	1	Control Door Support Rod Catch

* Specify key number when ordering.

Slide Meter Case Assembly

For models mfd. as of January 13, 1995

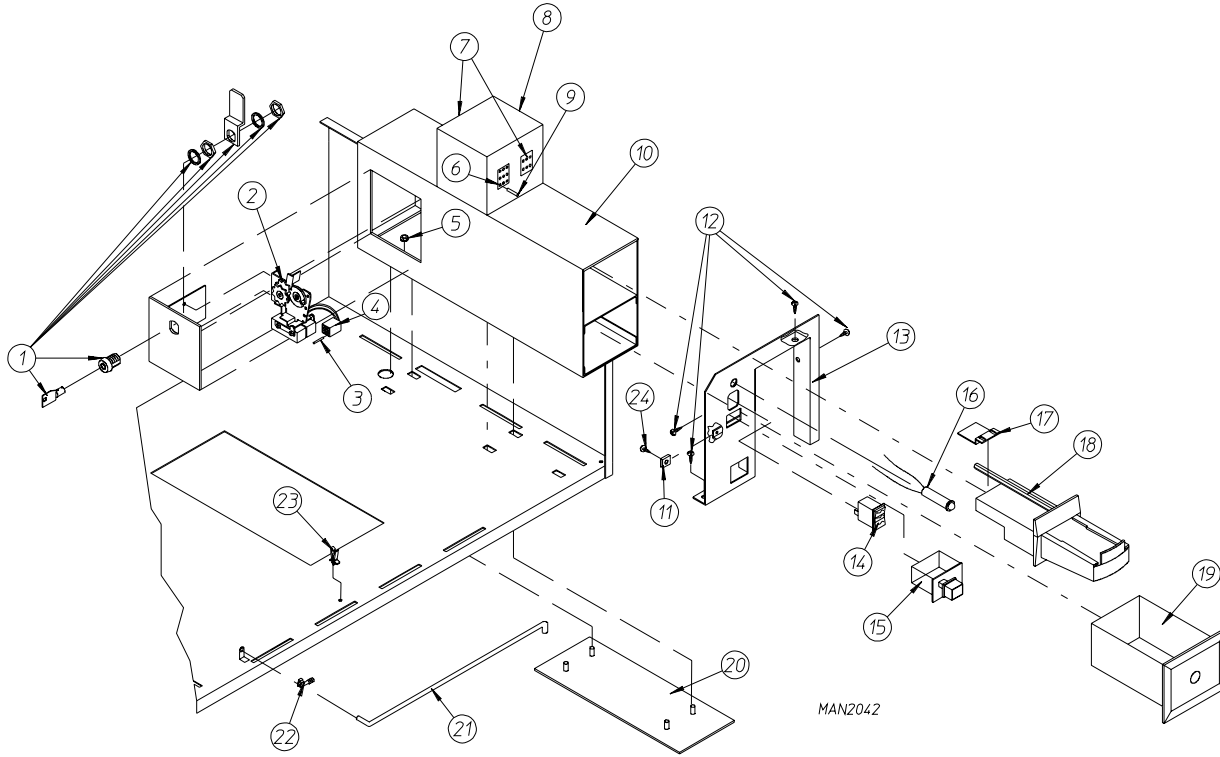

Illus. No.	Part No.	Qty.	Description
1	160099	1	Lock / Key / Cam and Hardware
	160199*	1	Key ONLY for Slide Meter Lock
2	125908	1	Slide Meter Accumulator – 24 VAC – 60 RPM (60 Hz Only)
3	122643	9	Mate-N-Lock Pin
4	122642	1	9-Position Mini-Universal Socket
5	152014	4	1/4-20 Free Spin Wash Nut
6	122603	1	9-Position Connector (Mate-N-Lock)
7	122631	2	6-Position Connector (Mate-N-Lock)
8	881100	1	Slide Meter Modular J-Box Assembly
9	122701	21	Socket Terminal
10	125900	1	Slide Meter Case with Door Less Lock
11	154001	2	#10-24 Speed Nut
12	150300	4	#10 x 1/2" Hex Washer TEK Screw
13	881015	1	Slide Meter Control Panel (Faceplate) Complete (includes illus. nos. 11 and 13 through 16)
	880937	1	Slide Meter Control Panel (Faceplate) ONLY
14	122400	1	Rocker Heat Selector Switch
15	131917	1	Push-to-Start Relay – 24 VAC
16	123005	1	Red Light Indicator – 24 VAC
17	125903	1	Slide Meter Extension
18	—	1	Typical Slide Meter Coin Chute (Not Available from ADC)
19	—	1	Typical Slide Meter Coin Box (Not Available from ADC)
20	801701	1	Slide Meter Case Mounting Plate
21	102502	1	Control Door Support Rod
22	102601	1	Control Door Support Rod Retainer Clip
23	102600	1	Control Door Support Rod Catch
24	150207	2	#10-24 x 1/2" Round Head Machine Screw

* Specify key number when ordering.

Slide Meter Case Assembly

For models mfd. prior to January 13, 1995

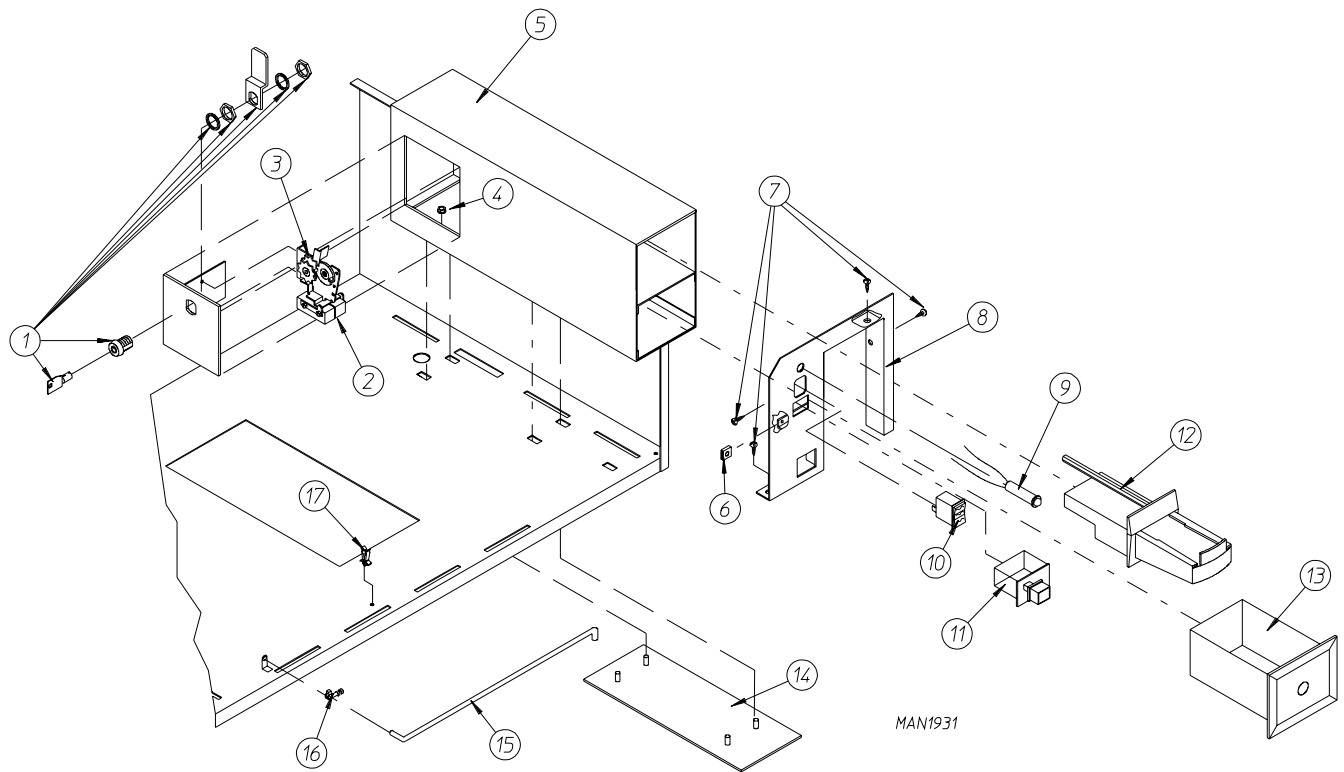

Illus. No.	Part No.	Qty.	Description
1	160099	1	Lock / Key / Cam and Hardware
	160199*	1	Key ONLY for Slide Meter Lock
2	125908	1	Slide Meter Accumulator – 24 VAC – 60 RPM (60 Hz Only)
3	123340	1	30-Minute 24 VAC Timing Motor (50 Hz Only)
	125541	1	60-Minute 24 VAC Timing Motor (60 Hz Only)
	125529	1	SLM Cam – 2 Point
	125523	1	SLM Cam – 3 Point
	125524	1	SLM Cam – 4 Point
	125525	1	SLM Cam – 6 Point
	125527	1	SLM Cam – 9 Point
	125521	1	SLM Cam – 10 Point
	125526	1	SLM Cam – 12 Point
4	152014	4	1/4-20 Free Spin Wash Nut
5	125900	1	Slide Meter Case with Door Less Lock
6	154001	2	#10-24 Speed Nut
7	150300	4	#10 x 1/2" Hex Washer TEK Screw
8	880937	1	Slide Meter Control Panel (Faceplate)
9	123005	1	Red Light Indicator – 24 VAC
10	122400	1	Rocker Heat Selector Switch
11	131917	1	Push-to-Start Relay – 24 VAC
12	—	1	Typical Slide Meter Coin Chute (Not Available from ADC)
13	—	1	Typical Slide Meter Coin Box (Not Available from ADC)
14	801701	1	Slide Meter Case Mounting Plate
15	102502	1	Control Door Support Rod
16	102601	1	Control Door Support Rod Retainer Clip
17	102600	1	Control Door Support Rod Catch

* Specify key number when ordering.

Main Door Assembly

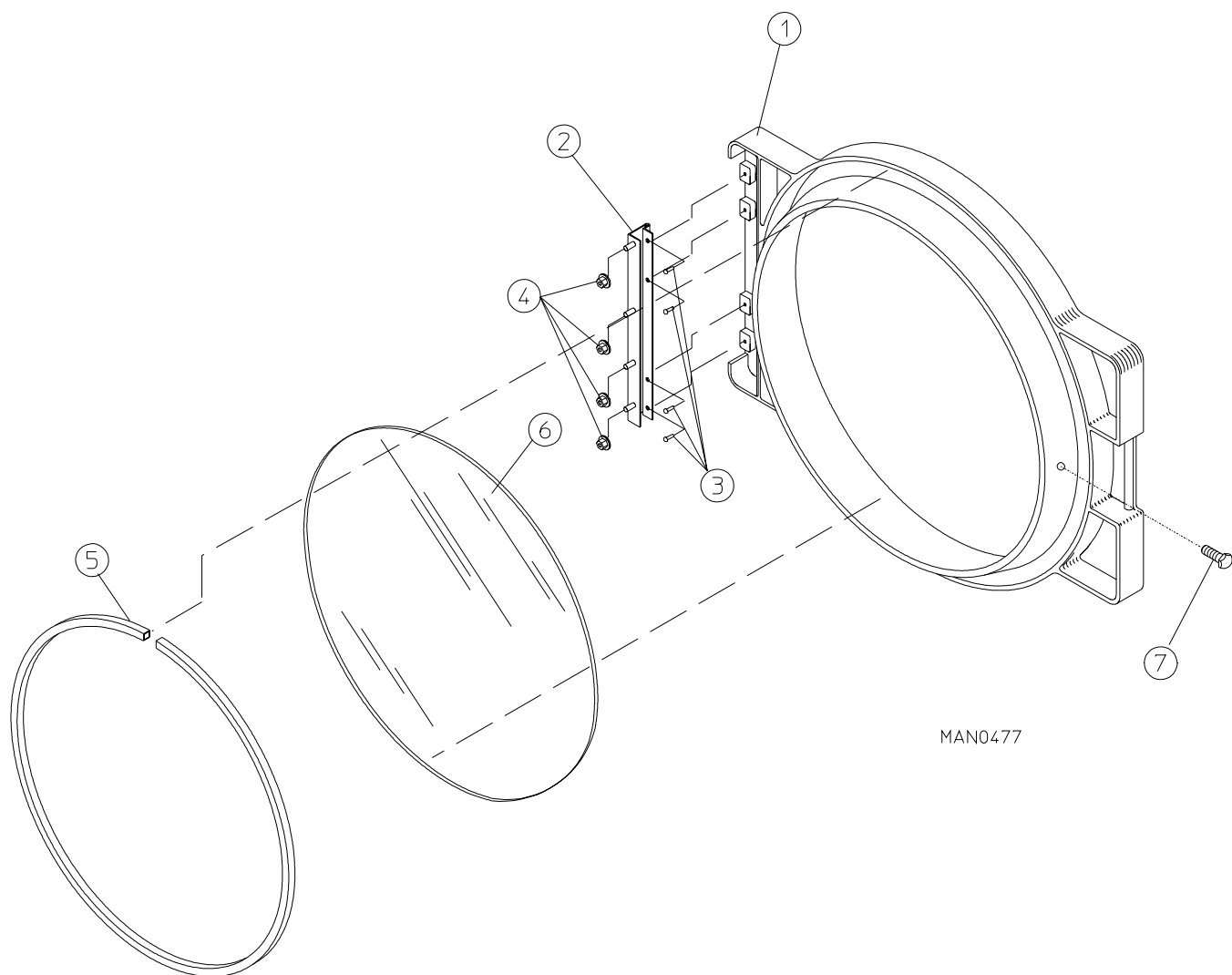

MAN0477

Illus. No.	Part No.	Qty.	Description
1	800285*	1	Gray (Lightweight) Main Door Assembly Complete (includes illus. nos. 1, 5, 6, and 7)
2	800448	1	12-1/2" Stainless Steel Main Door Hinge Assembly
3	150410	4	#10-24 x 3/8" Phillips Pan Head Taptite Screw
4	152014	4	1/4-20 Free Spin Wash Nut
5	102353	1	69-1/2" Main Door Gasket
6	102210	1	20-7/16" Door Glass
	170730	1	Main Door Glass Adhesive (10.3 oz. Cartridge)
7	150431	1	Main Door Latch Screw (#10 x 7/16" Dome Hex Head Screw)

* Contact factory for colors other than gray.

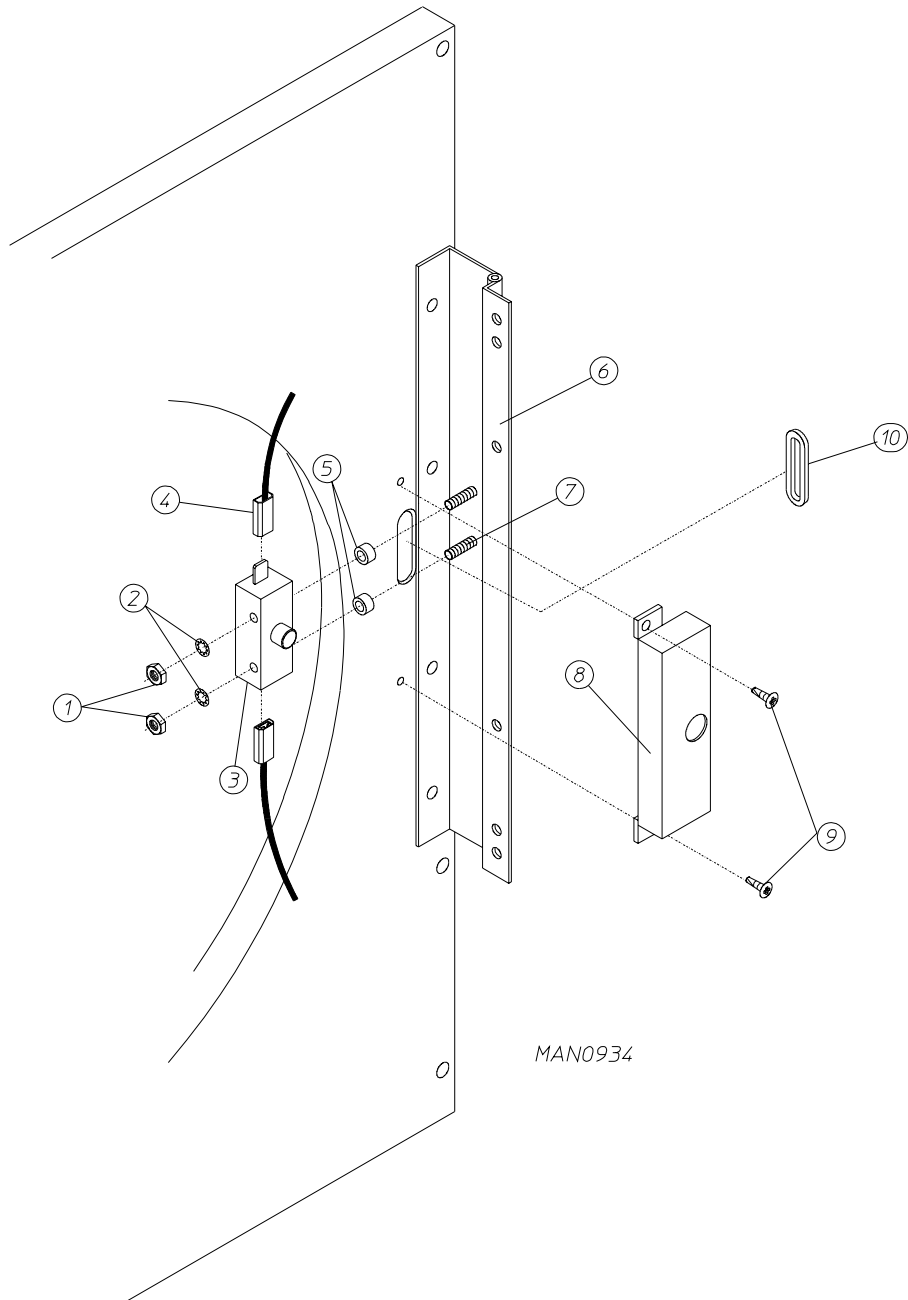

Illus. No.	Part No.	Qty.	Description
1	152013	2	#6-32 Hex Nut
2	153008	2	#6 Lock Washer
3	137005	1	Single Pole Door Switch
4	121028	2	Insulated Female Terminal
5	154281	2	3/8" Standard Nylon Spacer
6	800448	1	12-1/2" Stainless Steel Main Door Hinge Assembly (includes illus. nos. 6 and 7)
7	153565	2	#6 Stud
8	313218	1	Main Door Switch Housing
9	150201	2	#10-32 x 1/4" Phillips Pan Head Screw
10	121405	1	Rubber Grommet

Front Panel Assembly

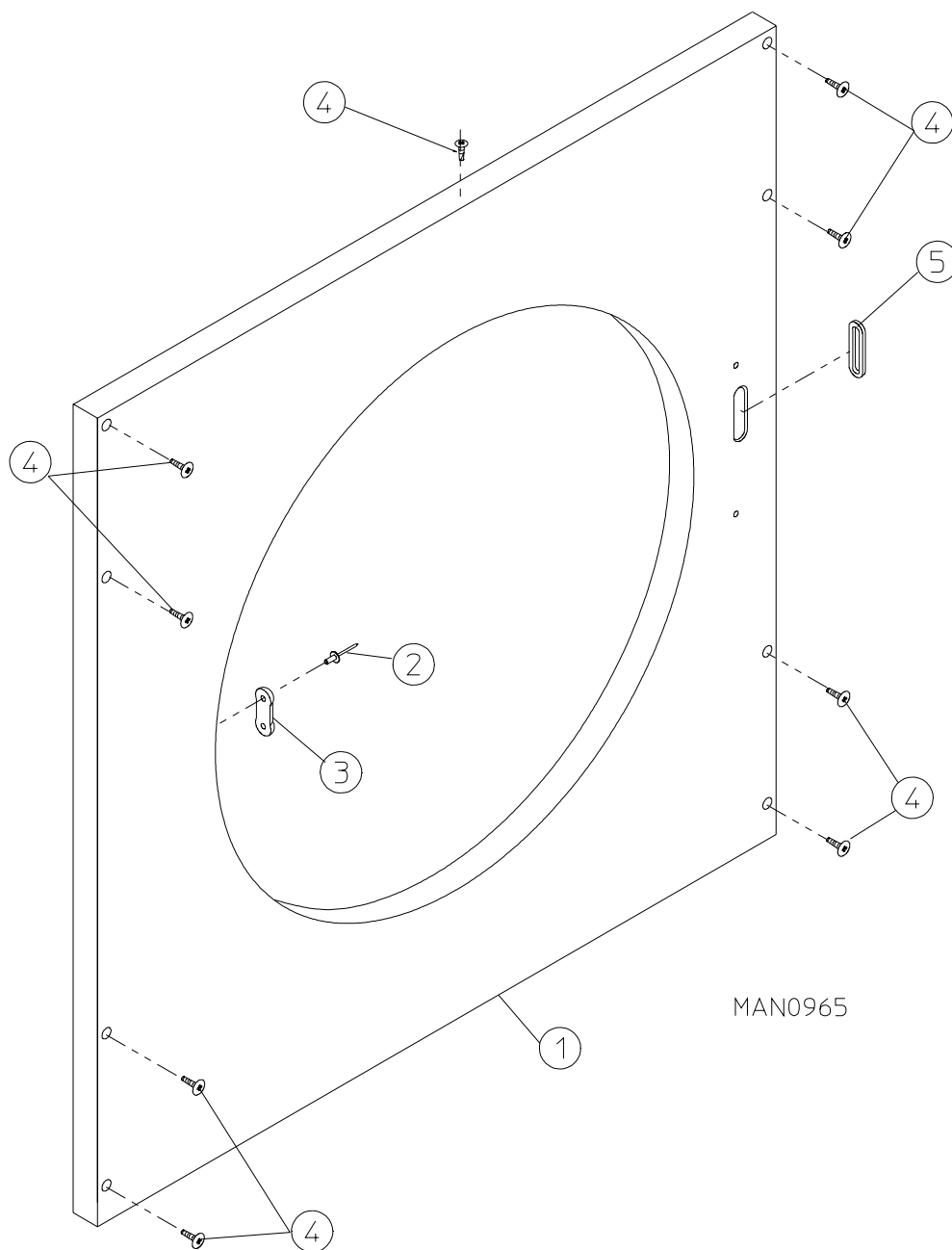

Illus. No.	Part No.	Qty.	Description
1	800675*	1	Front Panel Assembly Complete with Hinge (includes illus. nos. 1, 2, 3, and 5)
2	154215	2	5/32" Pop Rivet
3	170330	1	Friction Door Latch
4	150415	8	#10-16 x 1/2" Phillips Round Head Crimptite Screw
5	121405	1	Rubber Grommet

* Specify color when ordering.

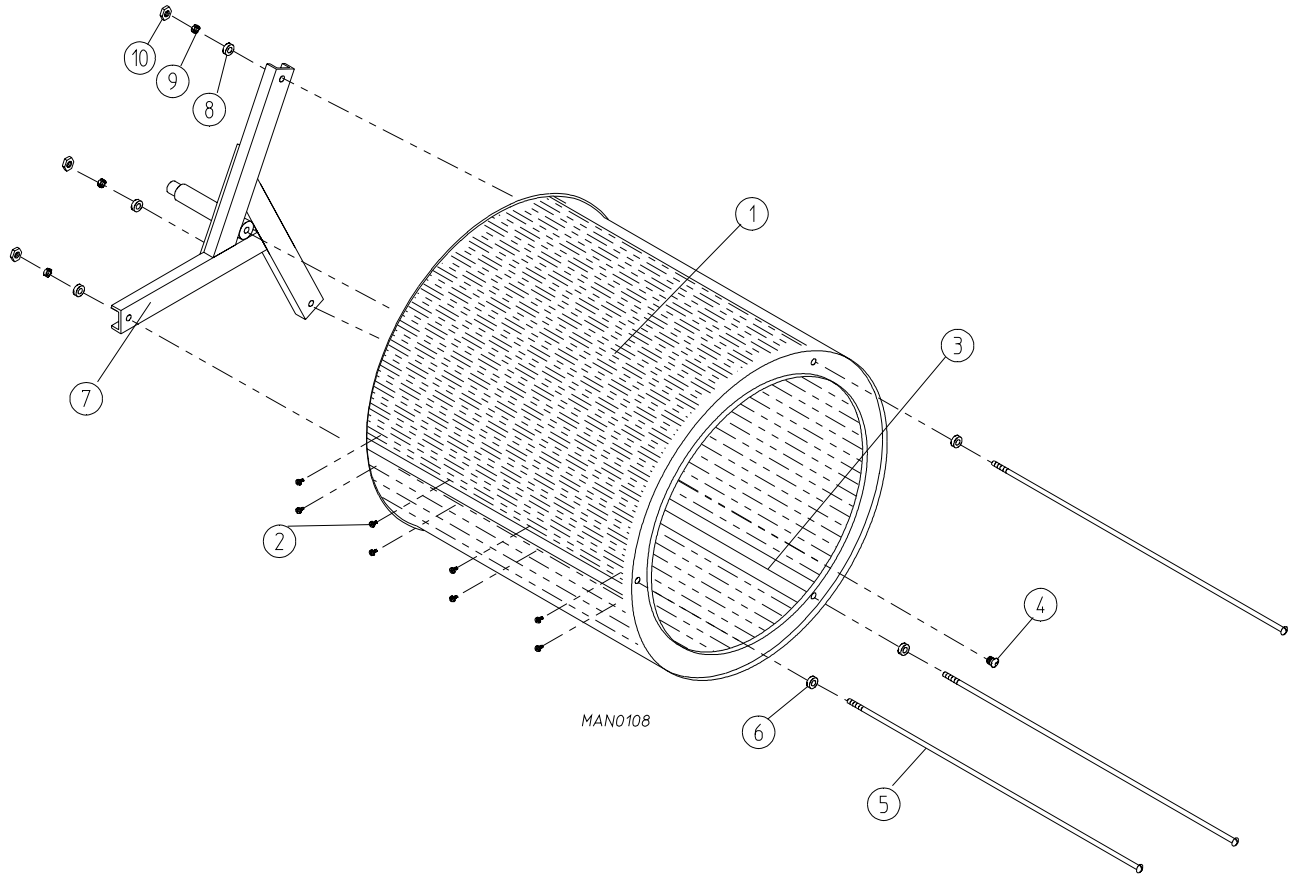

Illus. No.	Part No.	Qty.	Description
1	800843	1	Tumbler and Support Assembly Complete (includes illus. nos. 1 through 10)
	800717	1	Tumbler ONLY
2	150415	30	#10-16 x 1/2" Phillips Round Head Crimpite Screw
3	301318	2	Tapered Rib ONLY (Low Rib)
	301317	1	Tapered Rib ONLY (High Rib)
4	150518	1	5/16-18 x 3/8" Socket Screw
5	100907	3	5/16-18 x 25" Tie Rod
6	153003	3	3/8" x 1-1/2" Fender Washer
7	800612	1	Tumbler Support
8	153001	3	5/16" Flat Washer
9	153002	3	5/16" Lock Washer
10	152004	3	5/16-18 Hex Nut

Right Hand Hinged Lint Door Assembly

For models mfd. as of October 24, 1994

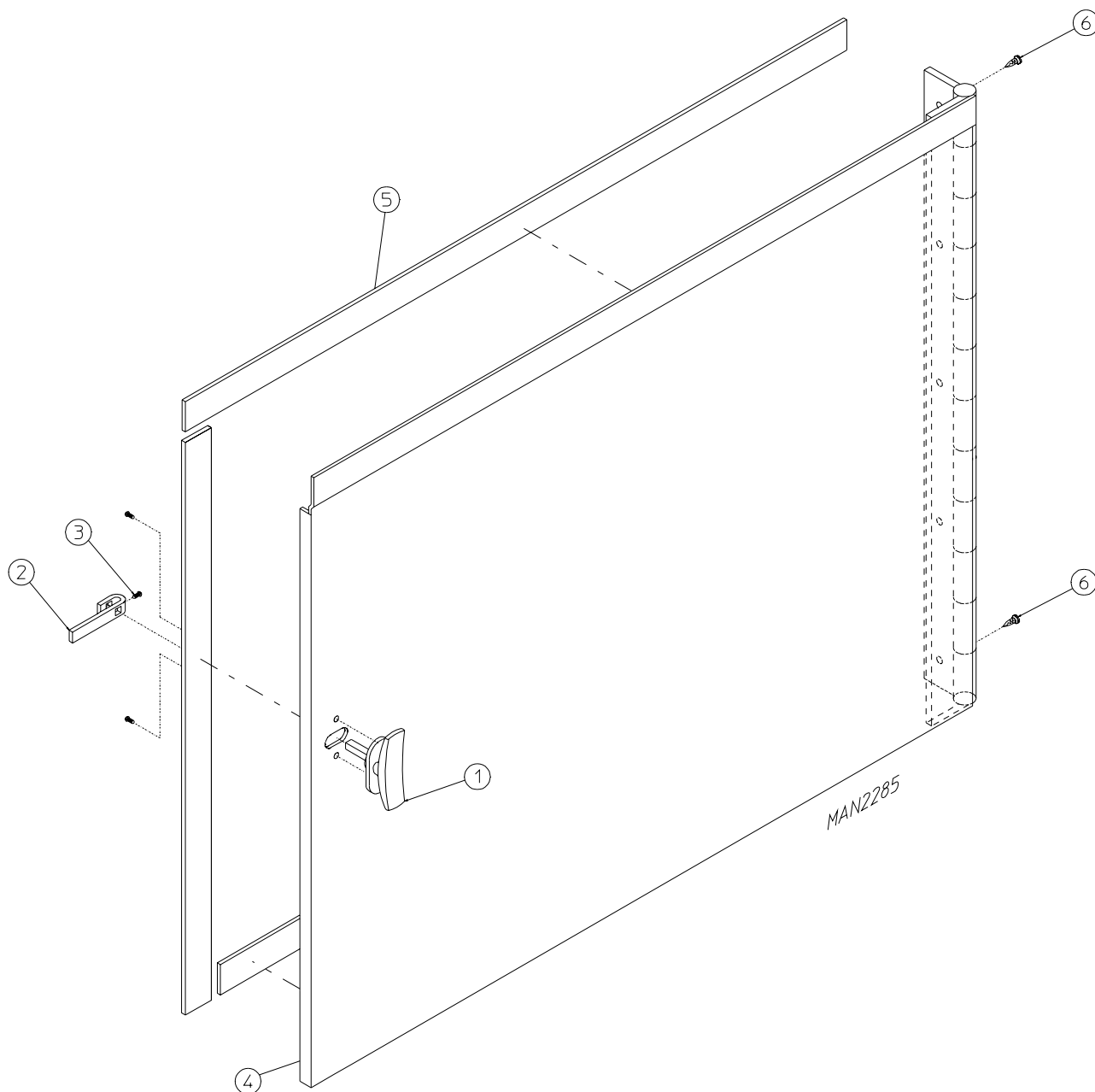

Illus. No.	Part No.	Qty.	Description
1	800150	1	Knob Latch Kit Complete (includes illus. nos. 1 through 3)
	160200	1	Knob Latch with 2 Screws
2	160009	1	Adjustable Cam
3	150425	1	#12-24 x 3/8" Screw for Adjustable Cam
4*	881138	1	Right Hand Hinged Lint Door Assembly (includes illus. nos. 4 and 5)
5	117604	7	Noise Suppressor Tape (sold by the foot)
6	150309	5	#10-16 x 1/2" Hex Head TEK Crimptite Screw

* Specify color when ordering.

Lint Door / Lint Drawer Assembly

For models mfd. between May 14, 1994 and October 24, 1994

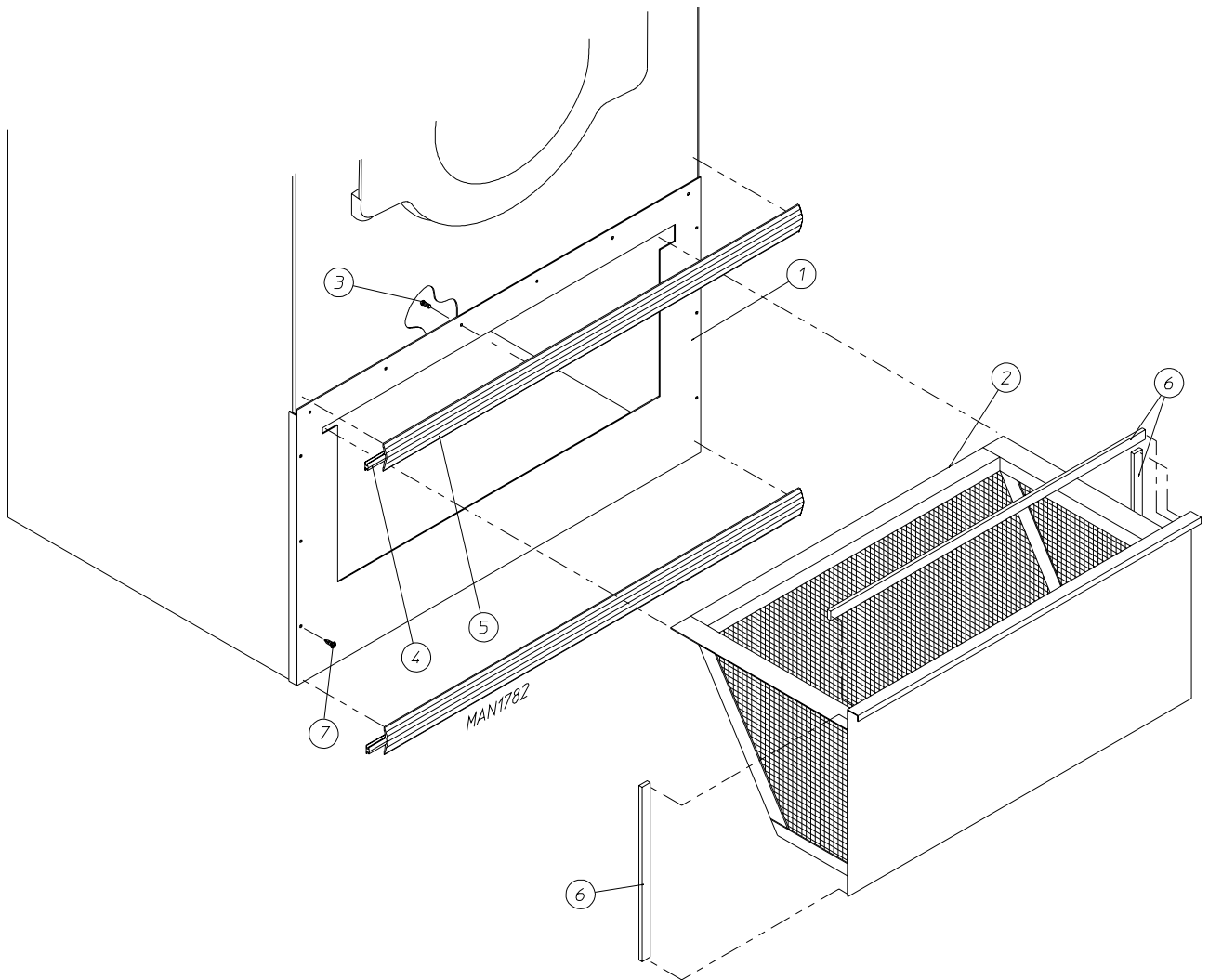

Illus. No.	Part No.	Qty.	Description
1*	881074	1	Lint Door Assembly (includes illus. nos. 1 and 3 through 5)
2*	850721	1	Lint Drawer Assembly (Non-Locking)
	850720	1	Lint Drawer Assembly (Locking) ... Not Illustrated
3	150201	12	#10-32 x 1/4" Phillips Pan Head Taptite Screw
4	117603	5	Trim Bumper Gasket (sold by the foot)
5	180213	2	Mid Trim Kick Plate
6	117600	7	Noise Suppressor Tape (sold by the foot)
7	150415	6	#10-16 x 1/2" Phillips Round Head Crimptite Screw

* Specify color when ordering.

Drop Lint Door Assembly

For models mfd. prior to May 14, 1994

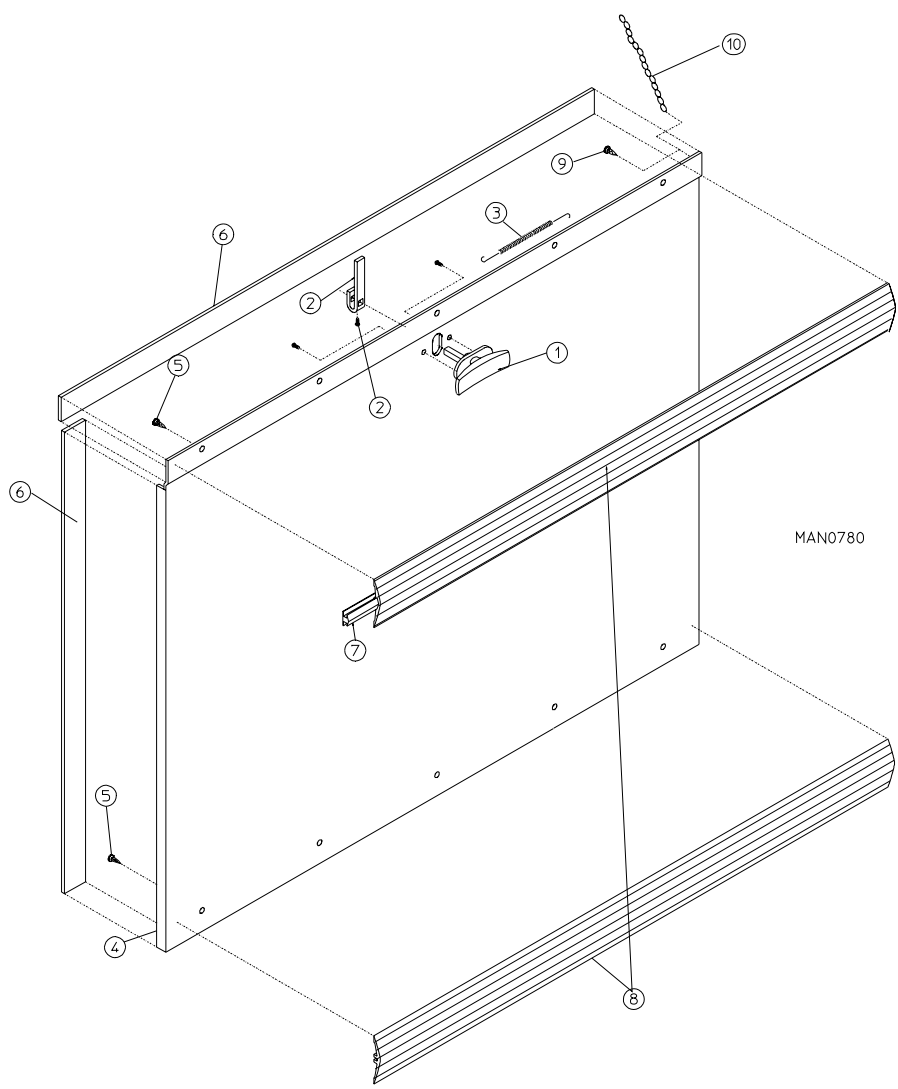

Illus. No.	Part No.	Qty.	Description
1	800150	1	Knob Latch Kit Complete (includes illus. nos. 1 and 2)
	160200	1	Knob Latch with 2 Screws
2	160009	1	Knob Latch Adjustable Cam
	150425	1	#12-24 x 3/8" Slotted Pan Head Screw for Adjustable Cam
3	157000	1	Drop Lint Door Spring
4*	800199	1	Drop Lint Door Assembly Complete (includes illus. nos. 4 through 8)
5	150201	10	#10-32 x 1/4" Phillips Pan Head Taptite Screw
6	117600	7	Noise Suppressor Tape (sold by the foot)
7	117603	3	Suppressor Tape / Gasket (sold by the foot)
8	180213	2	Mid Trim Kick Plate (28-3/8" length)
9	150415	1	#10-16 x 1/2" Phillips Round Head Crimptite Screw
10	108120	1	Chain for Drop Lint Door (sold by the foot)
	150418	1	Tamperproof Screw Hand Driver

* Specify color when ordering.

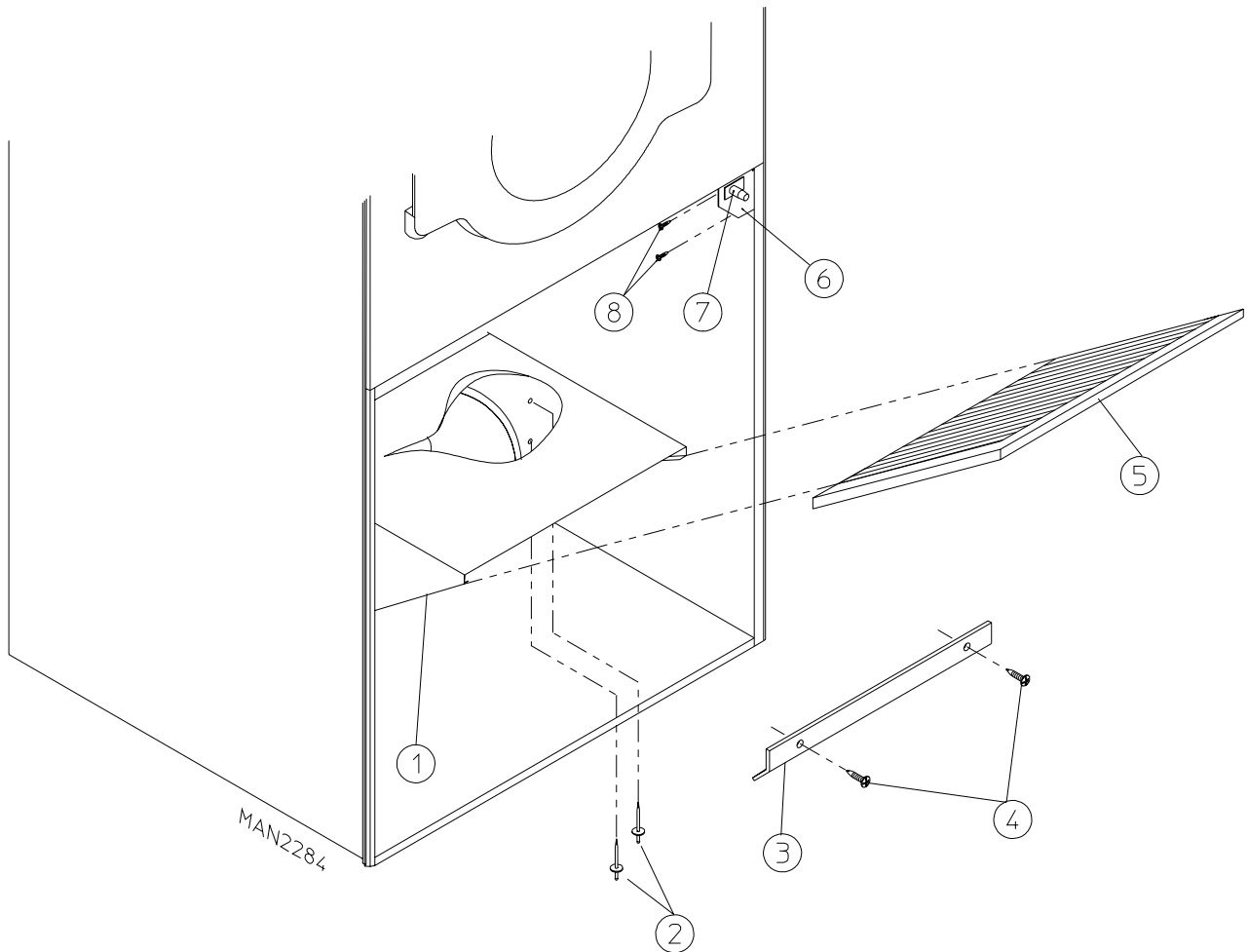

Illus. No.	Part No.	Qty.	Description
1	800429	1	Lint Trap Assembly Complete (includes illus. nos. 1, 3, 4, and 5)
	800419	1	Lint Trap ONLY
2	154200	7	5/32" Pop Rivet
3	304102	1	Lint Screen Holder
4	150300	3	#10 x 1/2" Hex Washer TEK Screw
5	800503	1	Lint Screen
6	323724	1	Lint Drawer Switch Bracket (for models mfd. as of August 2, 1994)
7	122116	1	Lint Drawer Switch (for models mfd. as of August 2, 1994)
8	150425	2	#12-24 x 3/8" Slotted Pan Head Screw (for models mfd. as of August 2, 1994)

Microprocessor Sensor Bracket Assembly

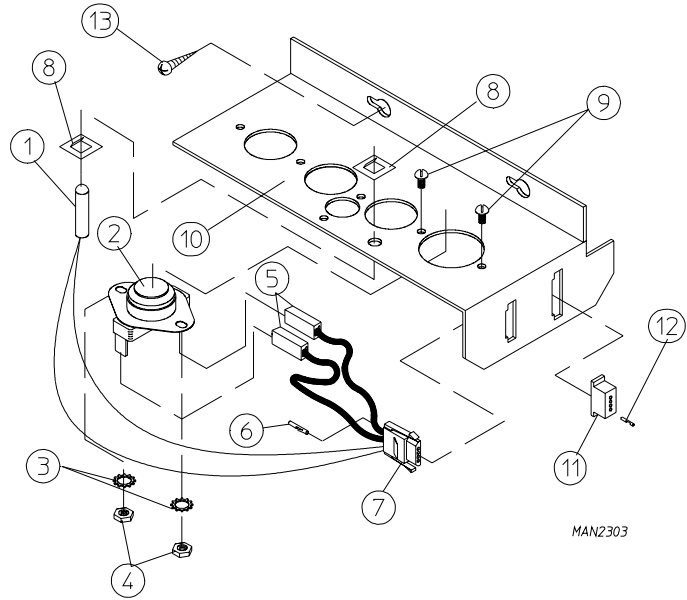

MAN2303

Noncomputer Sensor Bracket Assembly

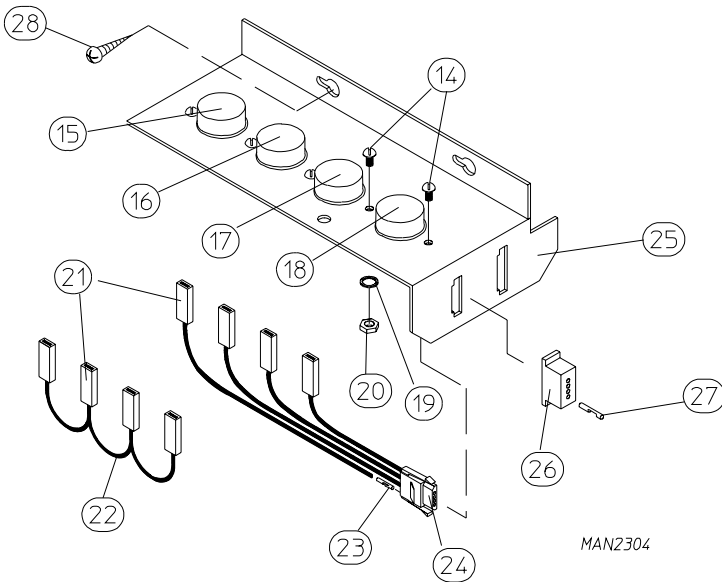

MAN2304

Illus. No.	Part No.	Qty.	Description
1	880251	1	1/4" Temperature Sensor Probe Assembly (includes illus. nos. 1 and 5 through 8)
2	130103	1	225° Large Automatic Reset Thermostat
3	153010	2	#6 Star Washer
4	152000	2	#6-32 Hex Nut
5	121028	2	Insulated Terminal
6	122701	4	Socket Terminal
7	122605	1	4-Pin Socket Connector
8	154007	2	1/4" Tinnerman Push-On Fastener
9	150005	2	#6-32 x 1/4" Round Head Machine Screw
10	801425	1	Microprocessor Sensor Bracket Assembly Complete (includes illus. nos. 1 through 10)

<u>Illus. No.</u>	<u>Part No.</u>	<u>Qty.</u>	<u>Description</u>
11	122604	1	4-Pin Connector
12	122700	4	Pin Terminal
13	150301	2	#8-18 x 7/16" Phillips Pan Head TEK Screw
14	150005	*	#6-32 x 1/4" Round Head Machine Screw
15	130103	1	225° Large Automatic Reset Thermostat (for models mfd. as of August 1, 1993)
16	130111	1	150° Large Thermostat (for models mfd. as of August 1, 1993)
	130103	1	225° Large Automatic Reset Thermostat (for models mfd. prior to August 1, 1993)
17	130100	1	130° Large Thermostat (for models mfd. as of August 1, 1993)
	130111	1	150° Large Thermostat (for models mfd. prior to August 1, 1993)
18	130101	1	180° Large Thermostat
19	153010	*	#6 Star Washer
20	152000	*	#6-32 Hex Nut
22	840065	1	Sensor Jumper (4) (for models mfd. as of August 1, 1993)
	840063	1	Sensor Jumper (3) (for models mfd. prior to August 1, 1993)
21	121028	**	Insulated Terminal
23	122701	***	Socket Terminal
24	122605	1	4-Pin Socket Connector (for models mfd. as of August 1, 1993)
	122609	1	3-Pin Socket Connector (for models mfd. prior to August 1, 1993)
	840062	1	Sensor (4) Bracket Harness Assembly (for models mfd. as of August 1, 1993) (includes illus. nos. 21, 23, and 24)
	831702	1	Sensor (3) Bracket Harness Assembly (for models mfd. prior to August 1, 1993) (includes illus. nos. 21, 23, and 24)
25	801418	1	Noncomputer Sensor (4) Bracket Harness Assembly Complete (includes thermostats) (for models mfd. as of August 1, 1993) (includes illus. nos. 14 through 27)
	801405	1	Noncomputer Sensor (3) Bracket Harness Assembly Complete (includes thermostats) (for models mfd. prior to August 1, 1993) (includes illus. nos. 14 and 16 through 27)
26	122604	1	4-Pin Connector (for models mfd. as of August 1, 1993)
	122608	1	3-Pin Connector (for models mfd. prior to August 1, 1993)
27	122700	***	Pin Terminal
	122801	1	Pin / Socket Extraction Tool
28	150301	2	#8-18 x 7/16" Phillips Pan Head TEK Screw

* Qty. = 4 or 5.

** Qty. = 6 or 8.

***Qty. = 3 or 4.

Tumbler Bearing Assembly

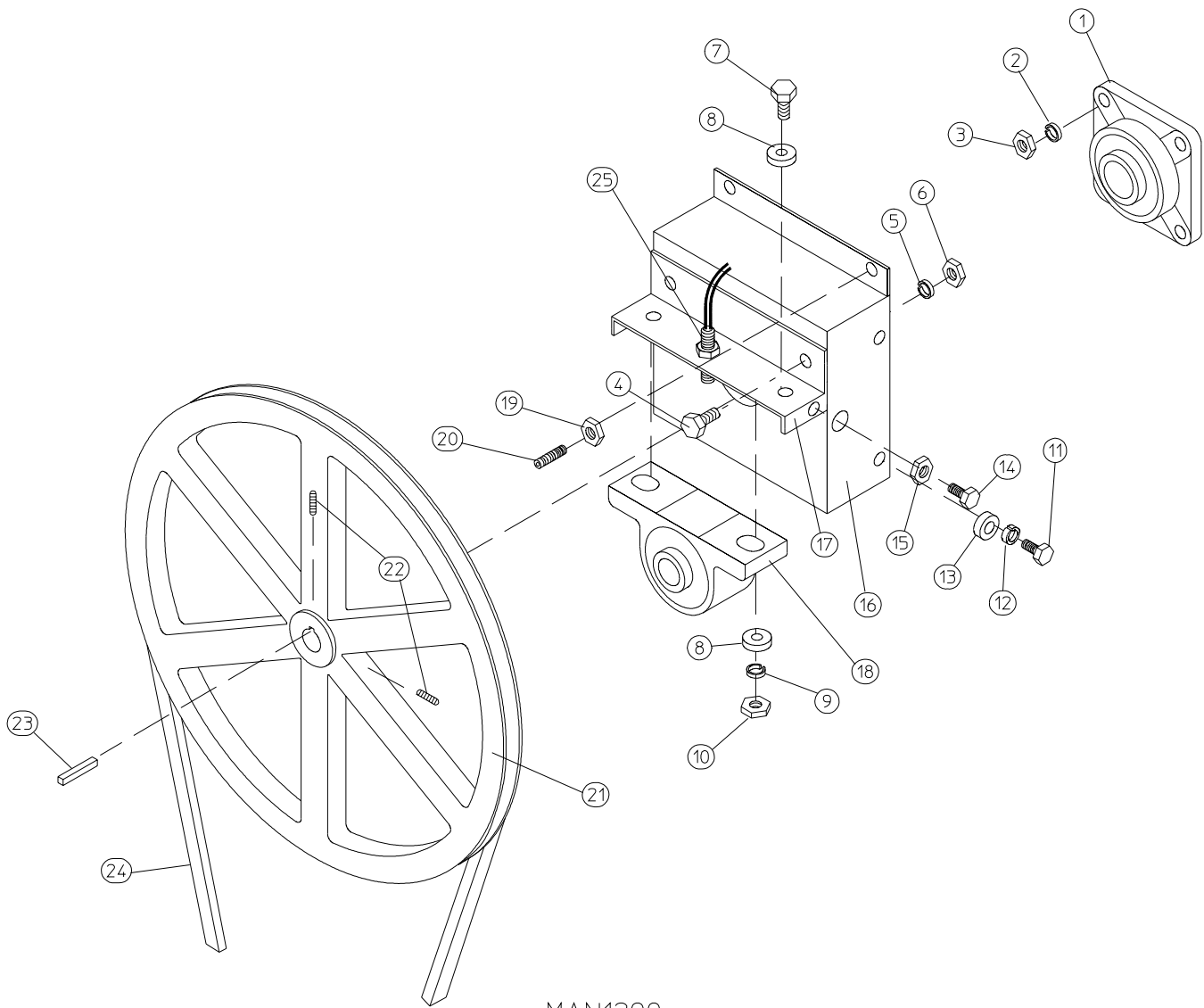

<u>Illus. No.</u>	<u>Part No.</u>	<u>Qty.</u>	<u>Description</u>
1	100203	1	1-3/8" Flange Bearing
2	153005	4	3/8" Lock Washer
3	152005	4	3/8-16 Hex Nut
4	150508	2	3/8-16 x 3/4" Hex Head Machine Bolt
5	153005	2	3/8" Lock Washer
6	152005	2	3/8-16 Hex Nut
7	150600	2	3/8-16 x 1-1/2" Hex Head Machine Bolt
8	153004	2*	3/8" Flat Washer
9	153005	2*	3/8" Lock Washer
10	152005	2*	3/8-16 Hex Nut
11	150501	4	5/16-18 x 3/4" Hex Head Machine Bolt
12	153002	4	5/16" Lock Washer
13	153001	4	5/16" Flat Washer
14	150621	2	5/16-18 x 1-1/2" Hex Head Machine Bolt
15	152004	2	5/16-18 Hex Nut
16	801101	1	1-3/8" Bearing Box Assembly Complete for Models Mfd. without Rotational Sensor (includes illus. nos. 4 through 20)
	801103	1	1-3/8" Bearing Box and Support ONLY (includes illus. nos. 4 through 6, 16, and 17)
	801105	1	1-3/8" Bearing Box ONLY
17	801104	1	Pillow Block Bearing Support
18	880202	1	1-3/8" Pillow Block Bearing
	880779	1	1-3/8" Pillow Block Bearing Assembly with Magnet for Models Mfd. with Optional Rotational Sensor
19	152004	2	5/16-18 Hex Nut
20	150610	2	5/16-18 x 1-1/2" Allen Setscrew
21	101100	1	18" Pulley
22	154301	2	5/16-18 x 5/16" Allen Cone Point Setscrew
23	100713	1	1/4" x 1/4" x 7/8" Key
24	100111	1	5L650 V-Belt (to Idler Assembly)
25	824807	1	Rotational Sensor Assembly (Optional)

* Some models require a quantity of 4.

Idler Bearing Assembly

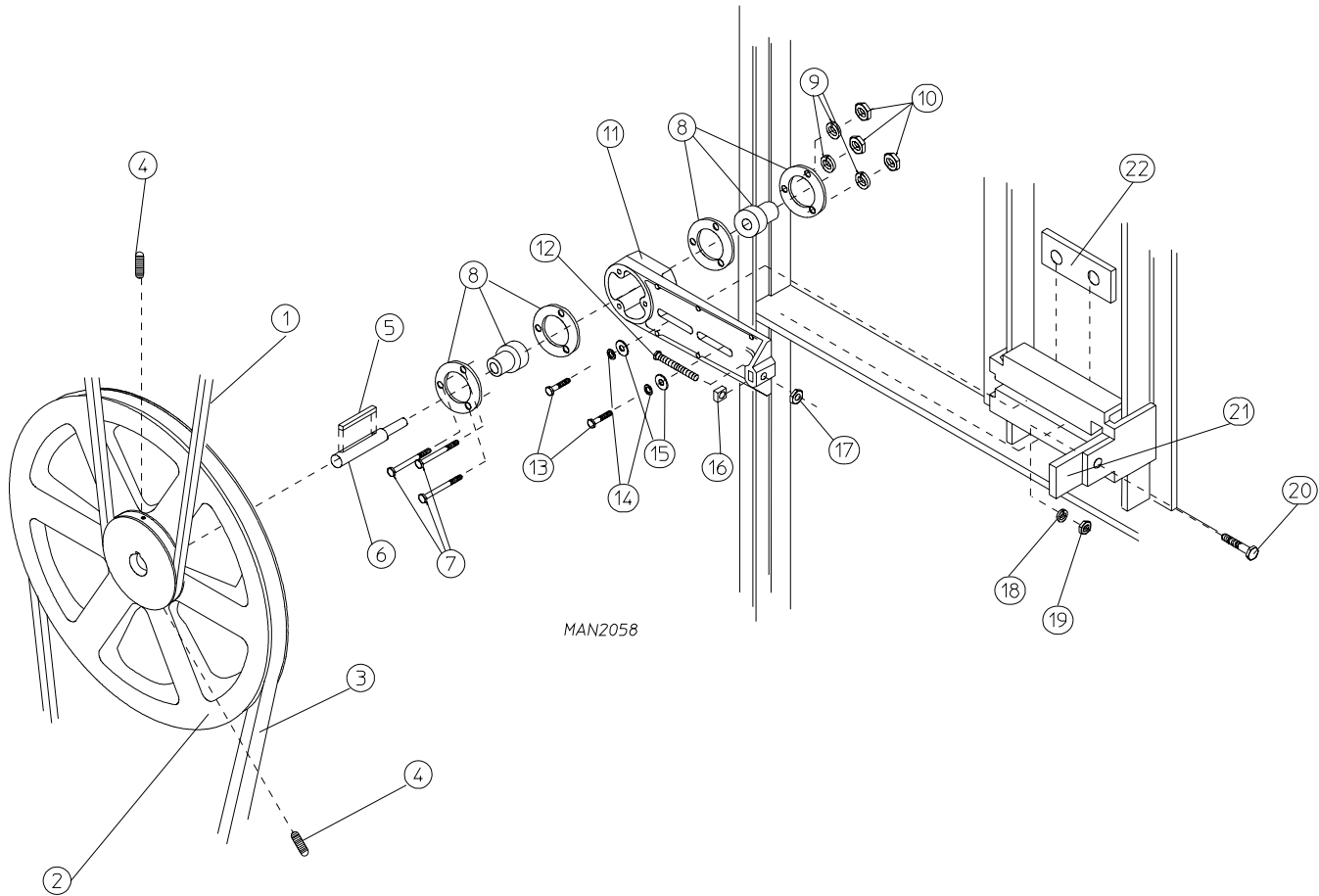

Illus. No.	Part No.	Qty.	Description
1	100111	1	5L650 V-Belt (to tumbler assembly)
2	101129	1	9" x 2-1/2" Compound Pulley
3	100105	1	4L520 V-Belt (to totally enclosed, fan-cooled motor mount assembly)
4	154301	2	5/16-18 x 5/16" Allen Setscrew
5	100705	1	3/16" x 3/16" x 1-3/8" Key
6	301850	1	5/8" x 3/4" Idler Shaft
7	150529	3	1/4-20 x 2-1/4" Carriage Bolt
8	100214	2	5/8" Flange Bearing
9	153007	3	1/4" Lock Washer
10	152002	3	1/4-20 Hex Nut
11	801008	1	Idler Bearing Assembly Complete (includes illus. nos. 5 through 22)
	100406	1	Idler Bearing Mount ONLY
12	150613	1	5/16-18 x 4" Hex Head Machine Bolt
13	150617	2	3/8-16 x 1" Hex Head Machine Bolt
14	153005	2	3/8" Lock Washer
15	153004	2	3/8" Flat Washer
16	152020	1	5/16-18 Standard Square Nut
17	152004	1	5/16-18 Hex Nut
18	152005	1	3/8-16 Hex Nut
19	153005	1	3/8" Lock Washer
20	150617	1	3/8-16 x 1" Hex Head Machine Bolt
21	301851	1	Idler Bracket Adjustment Plate
22	801009	1	Idler Square Washer

Totally Enclosed, Fan-Cooled Motor Mount Assembly

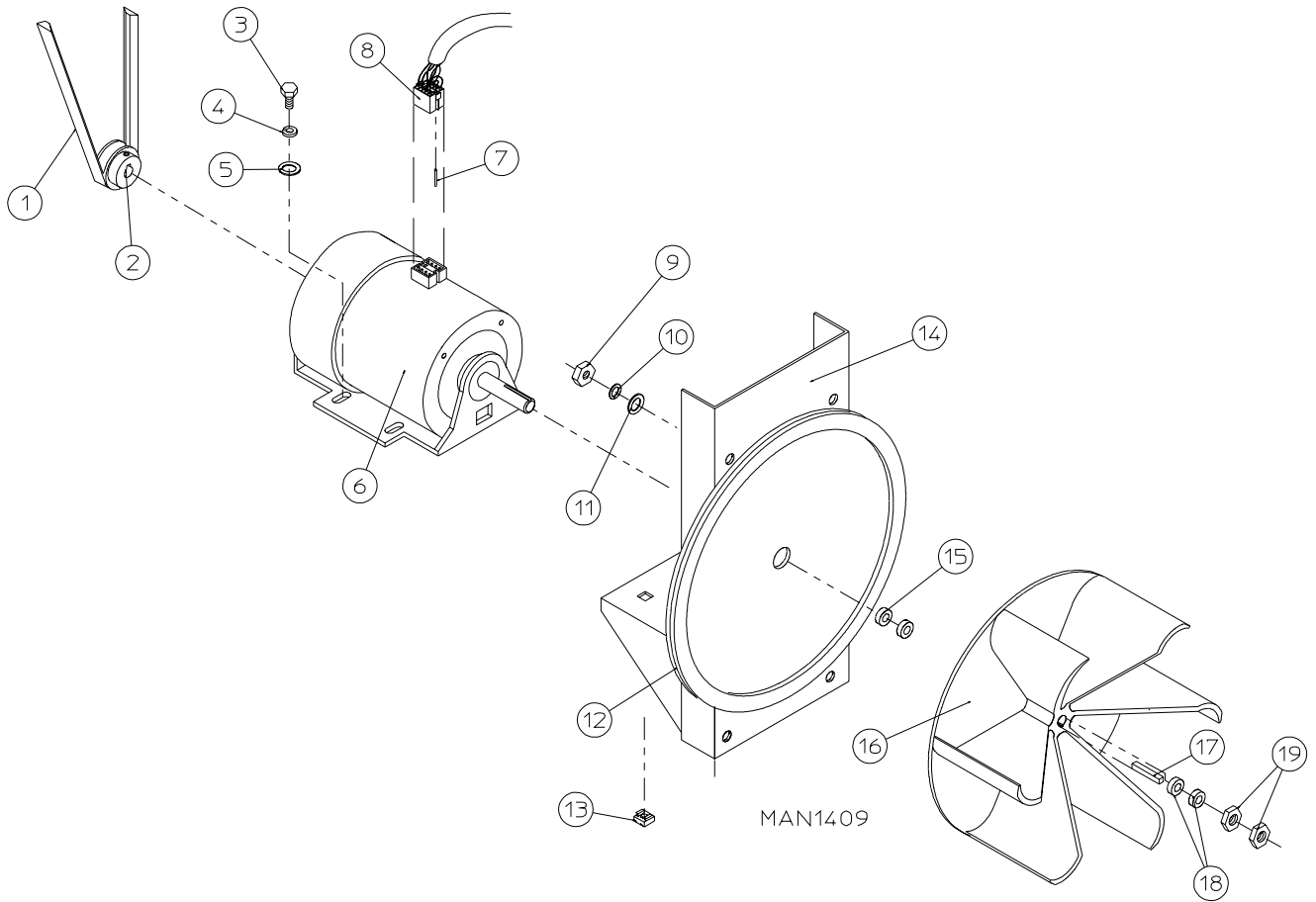

Illus. No.	Part No.	Qty.	Description
1	100105	1	4L520 V-Belt (to idler bearing assembly)
2	101131	1	1/2" x 2-1/4" Motor Pulley – (for use on 1Ø 60 Hz Models Only)
3	150501	4	5/16-18 x 3/4" Hex Head Machine Bolt
4	153002	4	5/16" Lock Washer
5	153001	4	5/16" Flat Washer
6	100065	1	1/2 hp / 115-230v / 60 Hz / 1Ø Totally Enclosed, Fan-Cooled Motor with Plug
7	122701	8	Socket Terminal
8	137030	1	8-Pin Housing Connector
	122801	1	Pin / Socket Extraction Tool
9	152004	4	5/16-18 Hex Nut
10	153002	4	5/16" Lock Washer
11	153001	4	5/16" Flat Washer
12	117600	4	Noise Suppressor Tape (sold by the foot)
13	154000	4	5/16-18 Tinnerman Nut
14	800909	1	1/2 hp Motor Mount ONLY (56Z Frame)
	803871	1	1/2 hp / 115-230v / 60 Hz / 1Ø Totally Enclosed, Fan-Cooled Motor Mount Assembly with Plug Motor (includes illus. nos. 3 through 8 and 13 through 19)
15	153050	2	1/2" S.A.E. Flat Washer
16	100604	1	12-1/2" Impellor (Fan) with 1/2" Bore
17	100702	1	1/8" x 1/8" x 1-1/2" Key
18	153050	2	1/2" S.A.E. Flat Washer
19	152006	2	1/2-20 Left Hand Jam Nut

* Specify voltage when ordering.

Direct Spark Ignition Burner Assembly

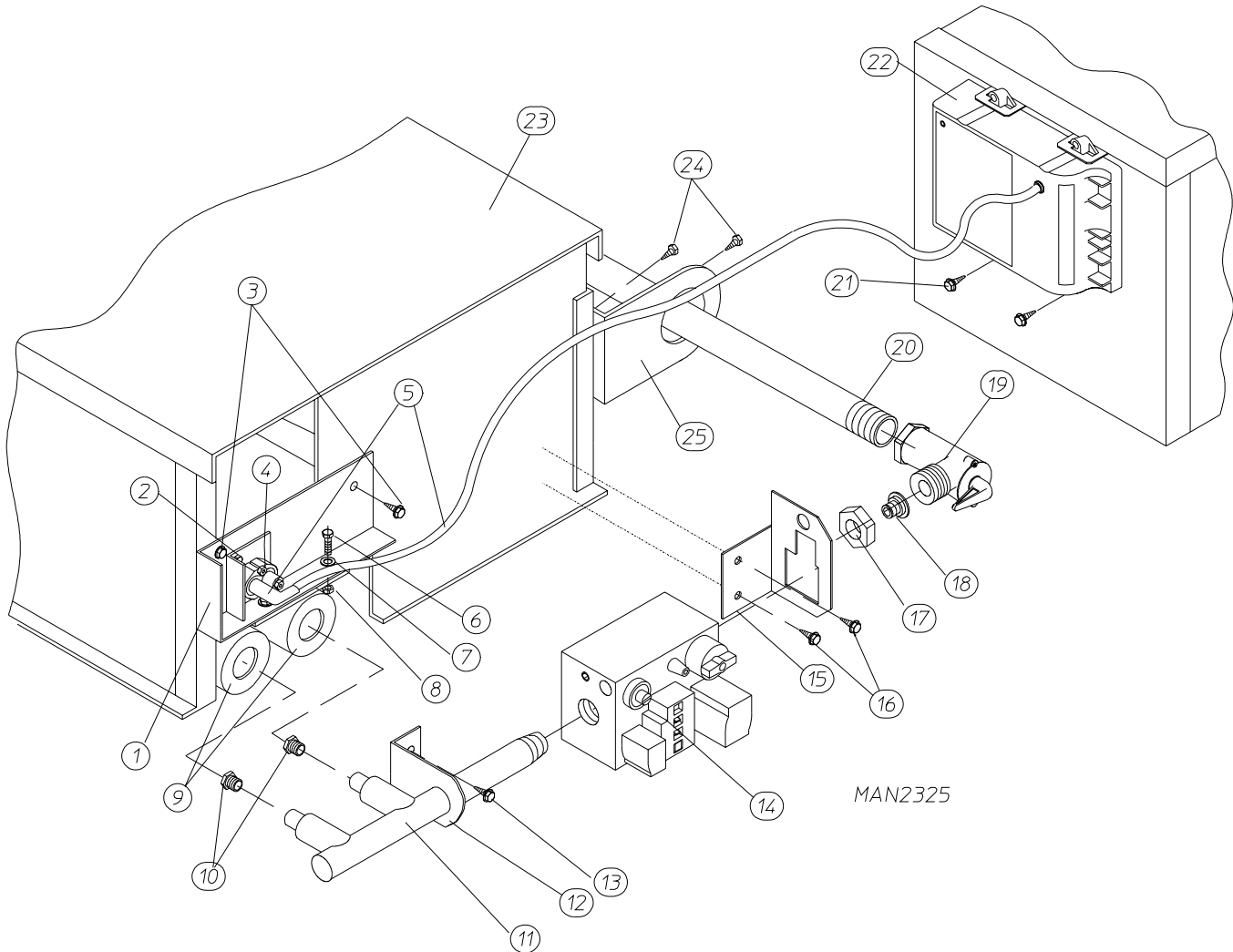

Direct Spark Ignition Burner Assembly

<u>Illus. No.</u>	<u>Part No.</u>	<u>Qty.</u>	<u>Description</u>
1	318030	1	Direct Spark Ignition Burner Shield
2	150300	2	#10 x 1/2" Hex Washer TEK Screw
3	150415	2	#10-16 x 1/2" Phillips Round Head Crimptite Screw
4	128915	1	Direct Spark Ignition Ignitor / Flame-Probe Assembly
	305410	1	Direct Spark Ignition Ignitor Gap Feeler Gauge ... Not Illustrated
5	884278	1	High Voltage Wire (for models with 1/4" spade connection at module)
	880330	1	High Voltage Wire (for models with spike style connection at module)
6	150108	2	#8-32 x 1/2" Pan Head Machine Screw
7	153000	2	#8 Steel Burr
8	151001	2	#8-32 Pal Nut
9	141104	2	Small Tube Burner
10*	140815	2	#37 Burner Orifice (natural gas)
	140800	2	#52 Burner Orifice (liquid propane)
11	141230	1	1/2" 2-Port Direct Spark Ignition Manifold
12	318700	1	Pipe Bracket (bent)
13	150415	2	#10-16 x 1/2" Phillips Round Head Crimptite Screw
14	128927	1	1/2" 24 VAC Redundant (natural gas) Gas Valve
	140411	1	1/2" Valve Conversion Kit (liquid propane)
15	318712	1	Gas Valve Pipe Bracket (for models mfd. as of August 10, 1995)
16	150415	2	#10-16 x 1/2" Phillips Round Head Crimptite Screw (for models mfd. as of August 10, 1995)
17	141325	1	Tailpiece Collar
18	141303	1	1/2" Union Tailpiece
19	141305	1	Union Shutoff Body
20	142809	1	1/2" x 29-1/8" Pipe
21	150299	2	#10 x 1" Hex Washer TEK Screw
22	883849	1	Direct Spark Ignition Module (includes high voltage wire)
23	809635	1	Direct Spark Ignition (natural gas) Burner Assembly Complete (less orifices) (includes illus. nos. 1 through 9 and 11 through 23)
	809644	1	Direct Spark Ignition (liquid propane) Burner Assembly Complete (less orifices) (includes illus. nos. 1 through 9 and 11 through 23)
	850850	1	Direct Spark Ignition Burner Box ONLY
24	150415	2	#10-16 x 1/2" Phillips Round Head Crimptite (for models mfd. prior to August 10, 1995)
25	318700	1	Pipe Bracket (bent) (for models mfd. prior to August 10, 1995)
—	874058*	1	ADG-24 Direct Spark Ignition (liquid propane) Conversion Kit (includes orifices)
—	410001	1	1/2" Allen Wrench (for removal of 1/2" Tailpiece Part No. 141303)

* Consult factory for elevations over 2,000 feet.

Electric Oven Assembly

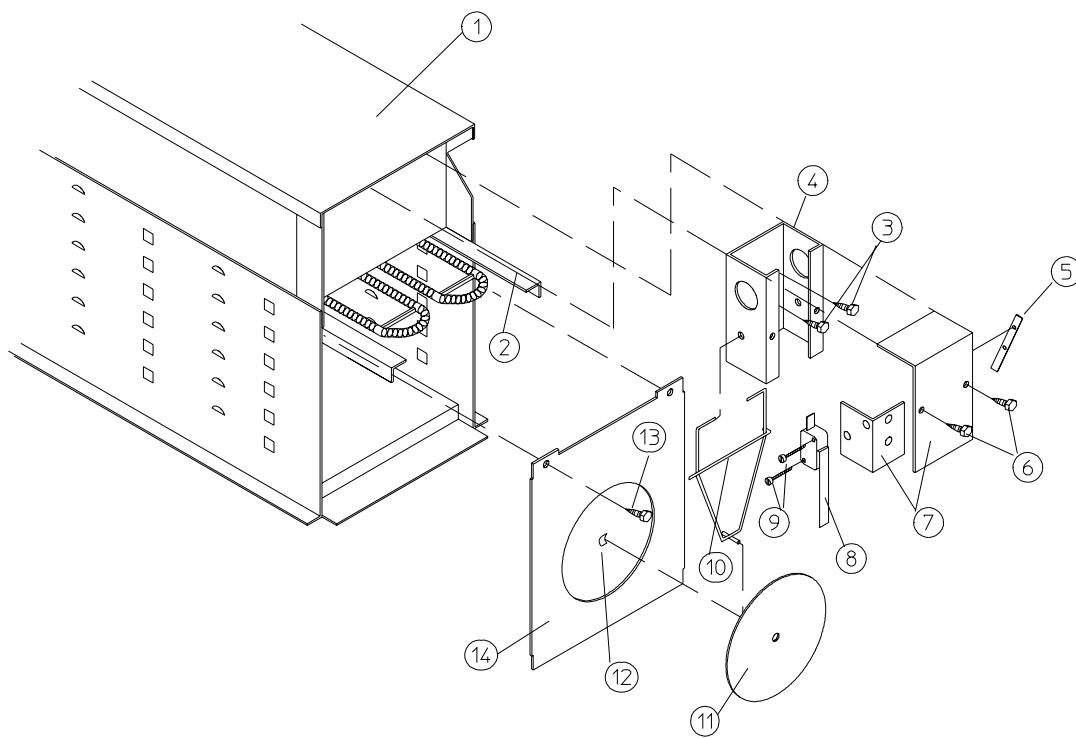

ELECTRIC OVEN (FRONT VIEW)

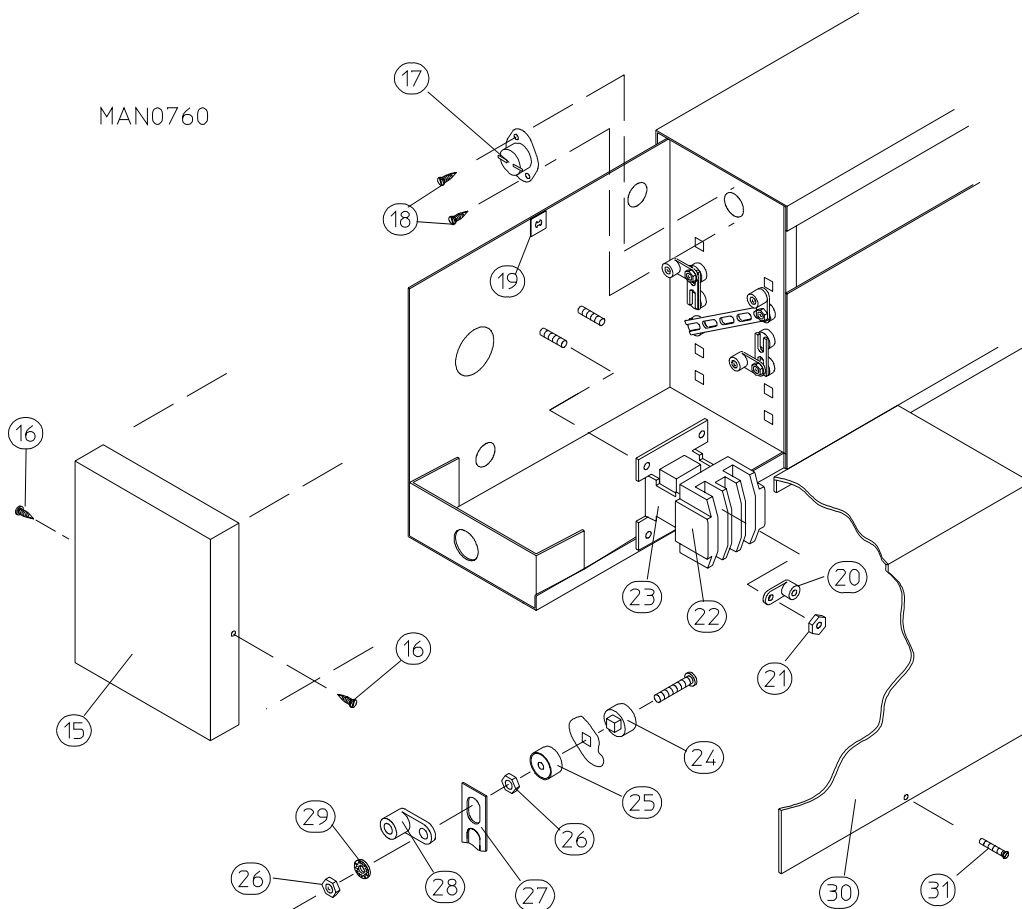

MAN0760

<u>Illus. No.</u>	<u>Part No.</u>	<u>Qty.</u>	<u>Description</u>
1	803003*	1	Electric Oven Box
	-----*	1	Electric Oven Assembly Complete
2	-----*	-	Electric Element
3	150300	2	#10 x 1/2" Hex Washer TEK Screw
4	802800	1	Sail Switch Box with Cover
	802801	1	Sail Switch Box Assembly Complete (includes illus. nos. 4 through 12)
5	154004	1	Twin Speed Nut
6	150415	2	#10-16 x 1/2" Phillips Round Head Crimptite Screw
7	802799	1	Sail Switch Box Cover
8	122200	1	Sail Switch
9	150303	2	#4 x 3/4" Pan Head "A" Machine Screw
10	105500	1	Sail Switch Actuator Rod
11	319202	1	Sail Switch Damper (flat)
12	154002	1	1/8" Push-On Fastener
13	150300	2	#10 x 1/2" Hex Washer TEK Screw
14	803100	1	Electric Oven Front Cover
15	320611	1	Large Relay Box Cover
16	150402	2	#10-24 x 5/8" Slotted Truss Head Machine Screw
17	130400	1	290° Hi-Limit
18	150300	2	#10 x 1/2" Hex Washer TEK Screw
19	154001	1	#10-24 Speed Nut
20	121010	1	L-70 Ground Lug
21	152014	3	1/4-20 Free Spin Wash Nut
22	-----*	1	Oven Relay
23	-----*	1	Oven Relay Replacement Coil
24	120081	-	Internal Ceramic Insulator (2 per element)
25	120080	-	External Ceramic Insulator (2 per element)
26	152008	-	#10-32 Hex Nut (4 per element)
27	121011	-	Bus Bar (sold by the foot)
28	-----*	-	Terminal Lug
29	153009	-	#10 Star Washer (2 per element)
30	321300	1	Large Electric Oven Right Side Cover
31	150402	2	#10-24 x 5/8" Slotted Truss Head Machine Screw

* Refer to Electric Oven Component Application Chart on page 35.

Sail Switch / Hi-Limit Assemblies

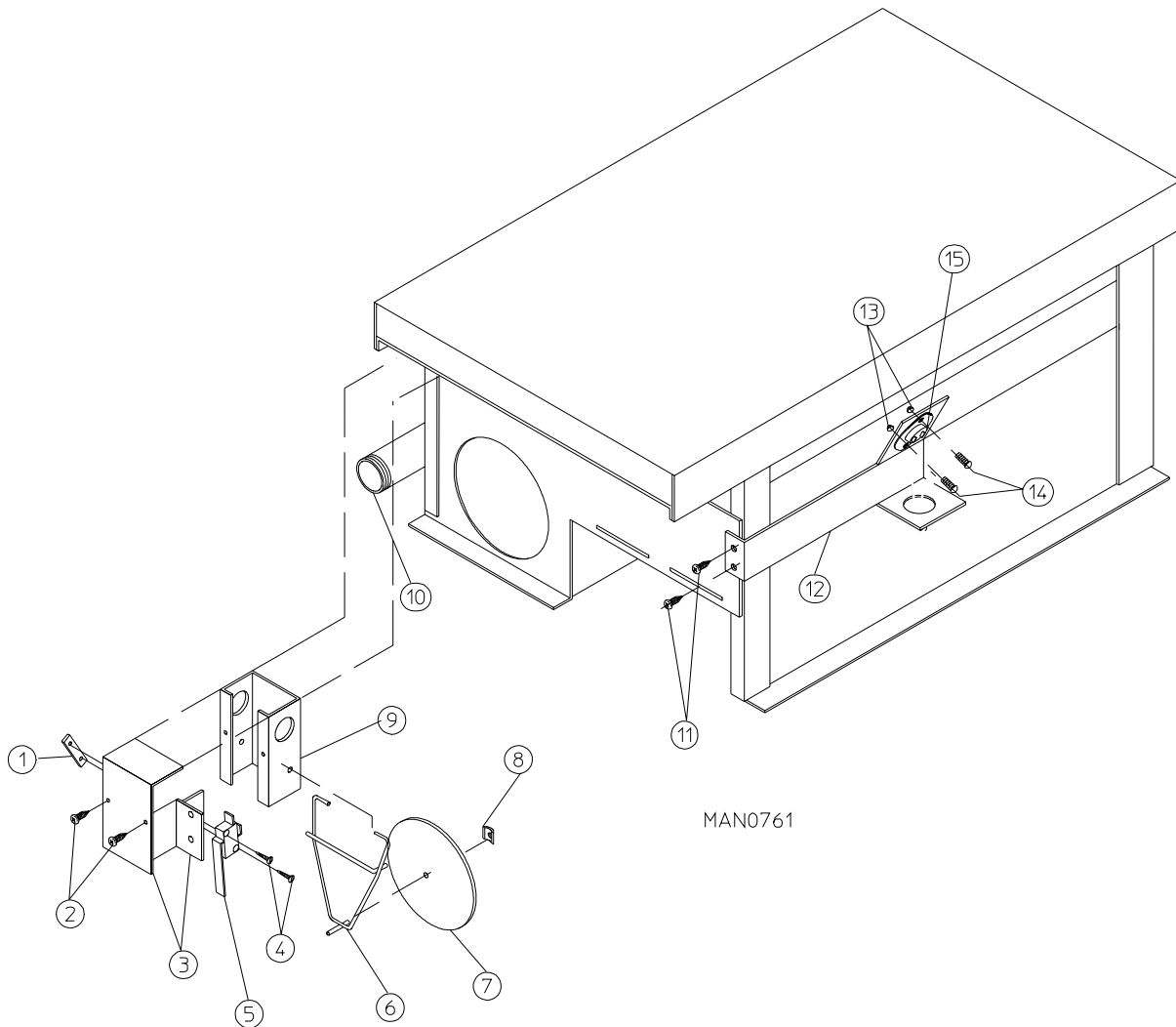

Illus. No.	Part No.	Qty.	Description
1	154004	1	Twin Speed Nut
2	150415	2	#10-16 x 1/2" Phillips Round Head Crimptite Screw
3	802799	1	Sail Switch Box Cover
4	150303	2	#4 x 3/4" Pan Head "A" Machine Screw
5	122200	1	Sail Switch
6	105500	1	Sail Switch Actuator Rod
7	319202	1	Sail Switch Damper (flat)
8	154002	1	1/8" Push-On Fastener
9	802801	1	Sail Switch Box Assembly Complete (includes illus. nos. 1 through 9)
	802800	1	Sail Switch Box with Cover
10	142809	1	1/2" x 29-1/8" Pipe
11	150415	2	#10-16 x 1/2" Phillips Round Head Crimptite Screw
12	319704	1	Hi-Limit Mounting Bracket
13	151000	2	#6-32 Pal Nut
14	150001	2	#6-32 x 1/2" Round Head Machine Screw
15	130403	1	330° Automatic Hi-Limit (for models mfd. as of June 7, 2000)
	130201	1	330° Manual Hi-Limit (for models mfd. prior to June 7, 2000)

Single-Phase Motor, Electric Relay Panel Assembly

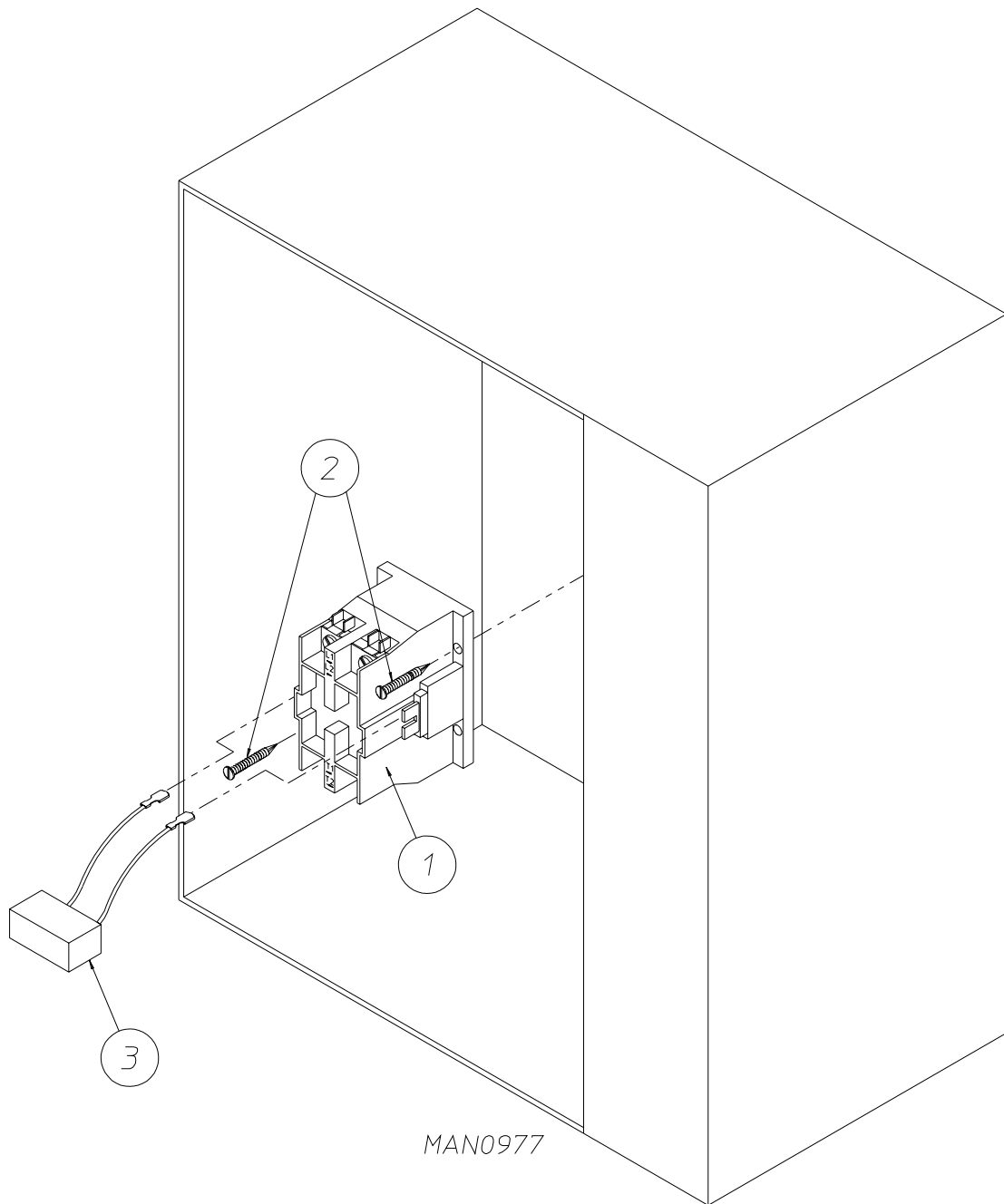

<u>Illus. No.</u>	<u>Part No.</u>	<u>Qty.</u>	<u>Description</u>
1	132451	1	2-Pole Contactor 24 VAC
2	150299	2	#10 x 1" Hex Washer TEK Screw
3	824828	1	RC Network with Connector
-	322809	1	Back Electrical Box Cover ... Not Illustrated
-	150301	4	#8-18 x 7/16" Phillips Pan Head TEK Screw ... Not Illustrated

Slide Meter Control Box Assembly

For models mfd. as of January 13, 1995

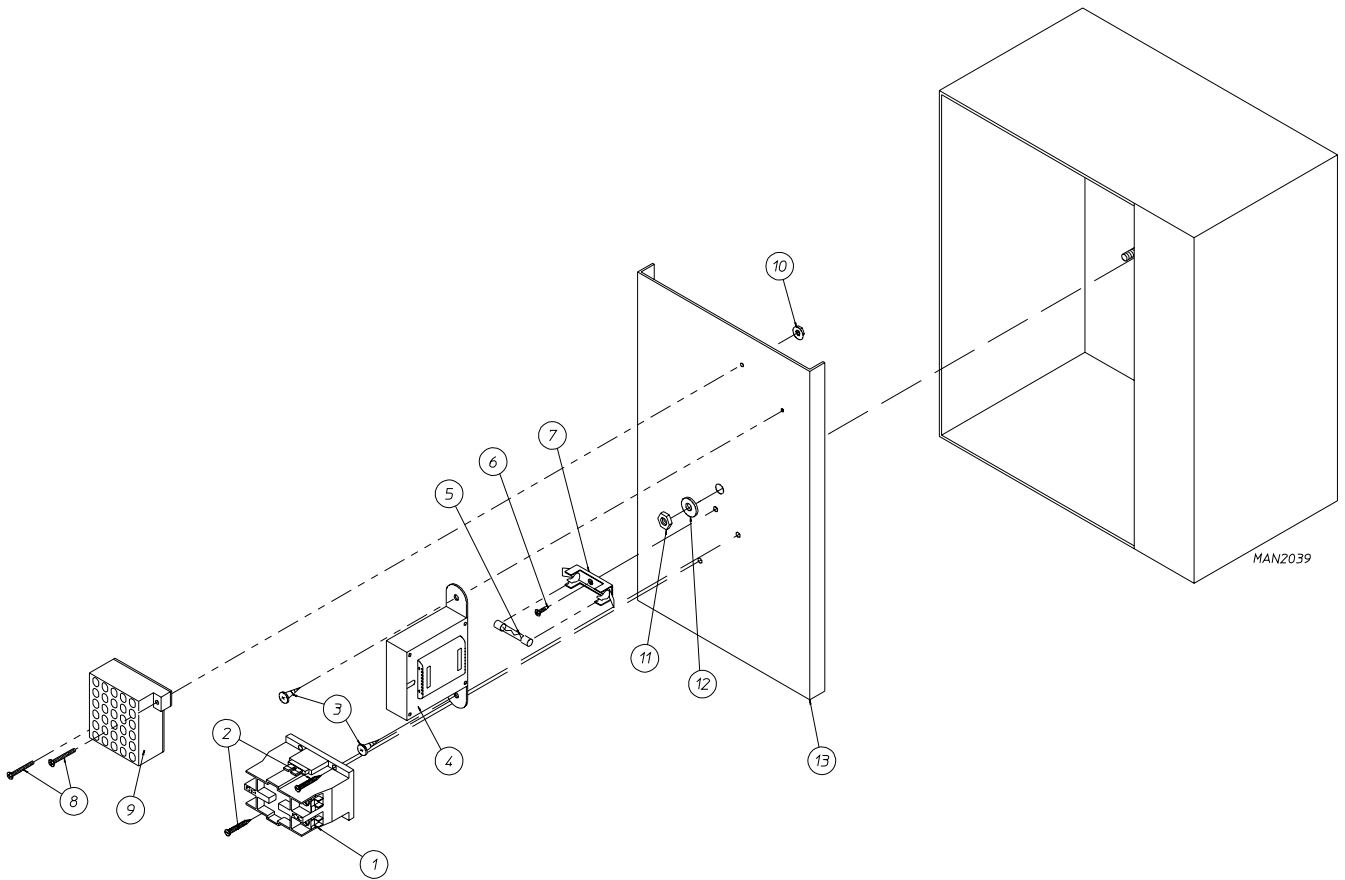

Illus. No.	Part No.	Qty.	Description
1	132451	1	2-Pole Contactor – 24 VAC
2	150299	2	#10 x 1" Hex Washer TEK Screw
3	150300	2	#10 x 1/2" Hex Washer TEK Screw
4	141403	1	Transformer – 24 VAC
5	136057	*	1/2-Amp (Slo-Blo) Fuse
6	150301	*	#8-18 x 7/16" Phillips Pan Head TEK Screw
7	136008	*	Fuse Block / Strip
8	150002	2	#6-32 x 1" Round Head Machine Screw
9	120715	1	30-Position Terminal Block
10	151000	2	#6-32 Pal Nut
11	152004	1	5/16-18 Hex Nut
12	153002	1	5/16-18 Lock Washer
13	305520	1	Rear Contact Plate
—	322809	1	Back Electrical Box Cover ... Not Illustrated
—	150301	4	#8-18 x 7/16" Phillips Pan Head TEK Screw ... Not Illustrated

* As required.

Slide Meter Control Box Assembly

For models mfd. prior to January 13, 1995

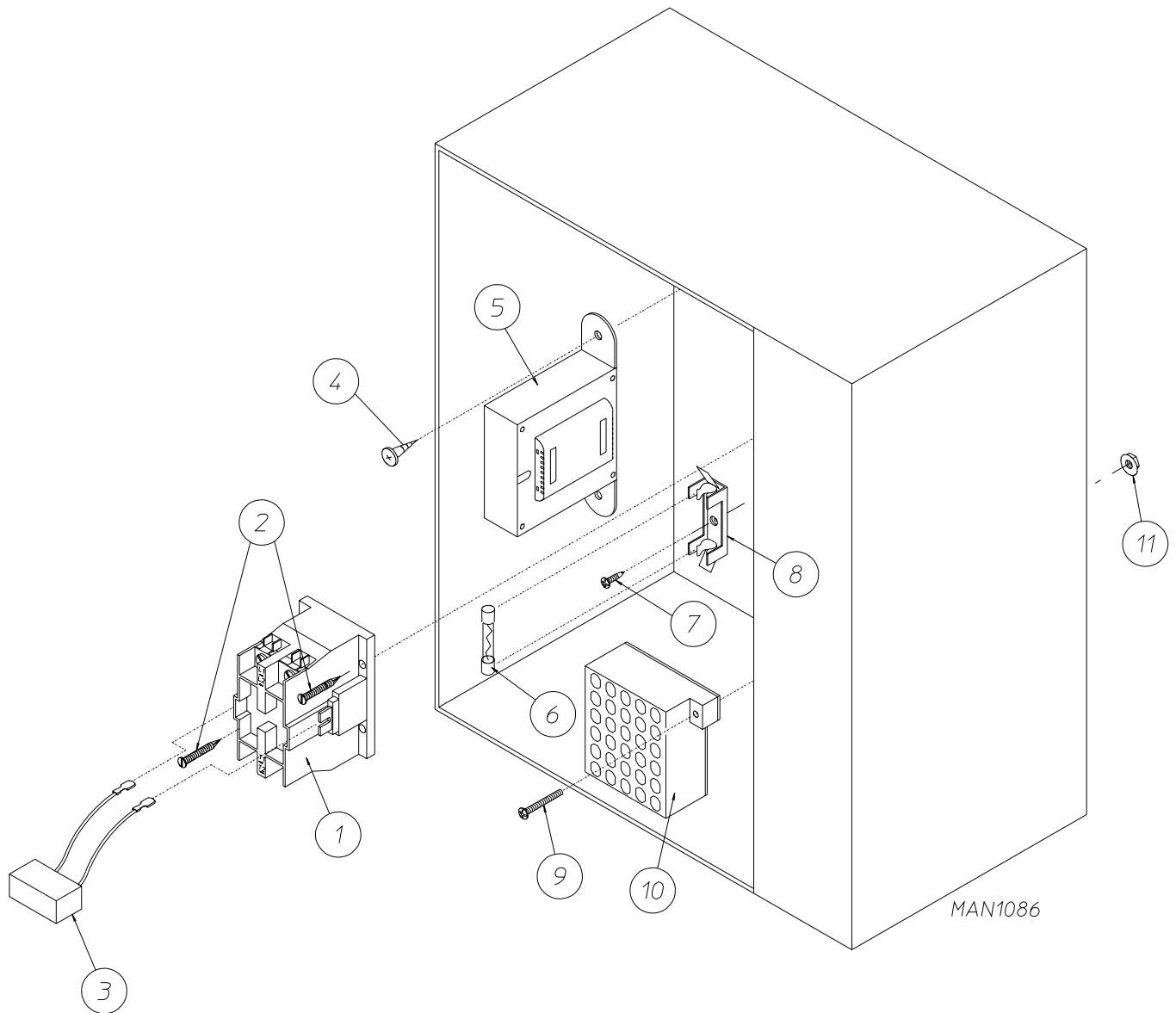

Illus. No.	Part No.	Qty.	Description
1	132451	1	2-Pole Contactor – 24 VAC
2	150299	2	#10 x 1" Hex Washer TEK Screw
3	824828	1	RC Network with Connector
4	150300	2	#10 x 1/2" Hex Washer TEK Screw
5	141403	1	Transformer – 24 VAC
6	136057	*	1/2-Amp (Slo-Blo) Fuse
7	150301	*	#8-18 x 7/16" Phillips Pan Head TEK Screw
8	136008	*	Fuse Block / Strip
9	150002	2	#6-32 x 1" Round Head Machine Screw
10	120715	1	30-Position Terminal Block
11	151000	2	#6-32 Pal Nut
—	322809	1	Back Electrical Box Cover ... Not Illustrated
—	150301	4	#8-18 x 7/16" Phillips Pan Head TEK Screw ... Not Illustrated

* As required.

Outer Top / Back Guard Assembly

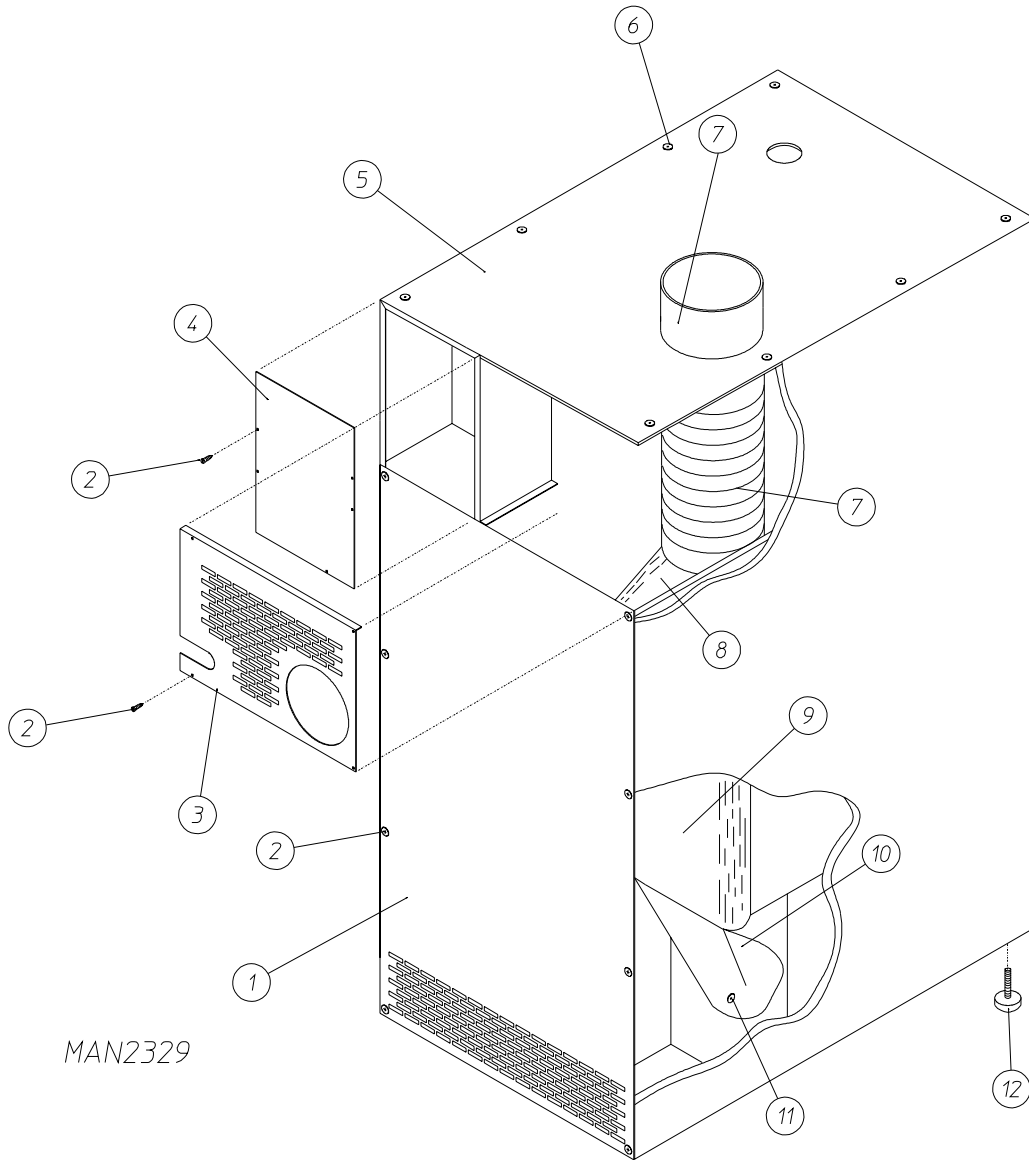

MAN2329

<u>Illus. No.</u>	<u>Part No.</u>	<u>Qty.</u>	<u>Description</u>
1	330608	1	"Plain" Back Guard (for models mfd. as of August 16, 1995)
	330636	1	"ADC Lettered" Back Guard (for models mfd. prior to August 16, 1995)
2	150301	16	#8-18 x 7/16" Phillips Pan Head TEK Screw
3	330638	1	Top Back Guard
4	322809	1	Back Electrical Box Cover
5	330618	1	Outer Top
6	150301	8	#8-18 x 7/16" Phillips Pan Head TEK Screw
7	143519	1	6' x 4' Flexible Exhaust Duct
8	804023	1	Transition Duct with 6" Damper
9	143540	1	18-1/2" Long x 7" Oval Duct
10	143515	1	6" Round x 7" Oval - 90° Boot
11	150300	2	#10 x 1/2" Hex Washer TEK Screw
12	103500	4	Adjustable Leveling Leg
—	117505	4	Aluminum Duct Tape (sold by the foot)

kW	Voltage	Phase	Wire	Oven Assembly * Part No.	Element			Oven Wire			Terminal Lug		Bus Bar Part No. 121011	Oven Relay		Relay Coil
					Qty.	kW	Part No.	Qty.	Size	Part No.	Qty.	Part No.		Cat. No.	Part No.	Part No.
24	460/480	3ø	3 or 4	824951	6	4	120009	4	#10	133000	6	121010	2	BEAJ	131350	131356
24	416	3ø	3 or 4	824945	6	4	120008	4	#8	133100	6	121010	2	BEAJ	131350	131356
24	240	3ø	3	824932	6	4	120009	3	#6	133200	3	121012	1	DEAJ	131365	131371
24	208	3ø	3 or 4	824915	6	4	120008	3	#4	133300	4	121012	1	DPA63	131369	N / A
20	380	3ø	3 or 4	824938	6	4	120008	4	#10	133000	6	121010	2	BEAJ	131350	131356
20	240	1ø	2	824927	5	4	120009	2	#4	133300	2	121012	2	FEAJ	131375	131386
20	208	1ø	2	824905	5	4	120008	2	#4	133300	2	121012	2	GEAJ	131385	131386
18	460/480	3ø	3 or 4	824950	6	3	120007	4	#10	133000	6	121010	2	BEAJ	131350	131356
18	416	3ø	3 or 4	824944	6	3	120006	4	#10	133000	6	121010	2	BEAJ	131350	131356
18	240	3ø	3	824931	6	3	120007	3	#8	133100	4	121010	2	DPA43	131357	N / A
18	240	1ø	2	824925	6	3	120007	2	#4	133300	2	121012	2	DPA63	131369	N / A
18	208	3ø	3 or 4	824914	6	3	120006	3	#6	133200	4	121010	2	DEAJ	131365	131371
18	208	1ø	2	824903	6	3	120006	2	#4	133300	2	121012	2	FEAJ	131375	131386
15	380	3ø	3 or 4	824937	6	3	120006	4	#10	133000	6	121010	2	BEAJ	131350	131356
15	240	1ø	2	824924	5	3	120007	2	#6	133200	3	121010	1	DPA63	131369	N / A
15	208	1ø	2	824902	5	3	120006	2	#4	133300	2	121012	1	DPA63	131369	N / A

* Oven assemblies do not include oven relay (contactor). This item must be ordered separately. When ordering Oven Assembly Complete, specify 3- or 4-wire when applicable, as well as if dryer has microprocessor or non-microprocessor controls.

N/A = Not available.

Microprocessor Coin Acceptor Listing

NOTE: Coin acceptors listed include optical switch (Part No. 137056).

Single Coin*

<u>ADC Part No.</u>	<u>Nation</u>	<u>Description</u>
125100	U.S. and Canada	.25¢ Optic Coin Acceptor
125127	Canada	\$1.00 Canadian Optic Coin Acceptor
125101	United Kingdom	10 New Pence Optic Coin Acceptor
125114	United Kingdom	20 New Pence Optic Coin Acceptor
125115	United Kingdom	1 Pound Optic Coin Acceptor
125106	France	1 French Franc Optic Coin Acceptor
125120	France	2 French Franc Optic Coin Acceptor
125124	France	5 French Franc Optic Coin Acceptor
125137	Denmark	New 1 Danish Krone Optic Coin Acceptor
125125	Netherlands	.25¢ Guilder Optic Coin Acceptor
125108	Australia	.10¢ Australian Optic Coin Acceptor
125107	Australia	.20¢ Australian Optic Coin Acceptor
125130	Australia	\$1.00 Australian Optic Coin Acceptor
125123	New Zealand	.50¢ New Zealand Optic Coin Acceptor
125104	Japan	100 Yen Optic Coin Acceptor
125103	—	.882 Token Optic Coin Acceptor
125121	—	.800 Token Optic Coin Acceptor
125129	—	Muller Token Optic Coin Acceptor
125132	Singapore	.50¢ Singapore Optic Coin Acceptor
125133	Hong Kong	\$1.00 Hong Kong Optic Coin Acceptor

Dual Coin*

<u>ADC Part No.</u>	<u>Nation</u>	<u>Description</u>
125112	United Kingdom	10 / 20 Pence Dual Optic Coin Acceptor
125110	United Kingdom	10 / 50 Pence Dual Optic Coin Acceptor
125111	United Kingdom	20 / 50 Pence Dual Optic Coin Acceptor
125113	United Kingdom	1 Pound / 20 Pence Dual Optic Coin Acceptor
125122	France	2 / 5 French Franc Dual Optic Coin Acceptor
125134	Denmark	New 1 / 5 Danish Krone Dual Optic Coin Acceptor
125138	Denmark	New 5 / 10 Danish Krone Dual Optic Coin Acceptor
125126	Netherlands	.25¢ / \$1.00 Guilder Dual Optic Coin Acceptor
125118	Singapore	.20¢ / .50¢ Singapore Dual Optic Coin Acceptor
125105	Japan	50 / 100 Yen Dual Optic Coin Acceptor

* Consult factory for coin acceptors not listed.

<u>Part No.</u>	<u>Description</u>
112027	“Water Washed Fabrics” Label
112040	“Lint Compartment” Label
112041	“Caution – Exhausted” Label
112533	“Phase 5 Coin Program Location Summary” Label
112534	“Phase 5 OPL Program Location Summary” Label
120100	3/8” Straight (BX) Connector
120300	3/8” x 45° (BX) Connector
120400	3/8” Red Jacket (BX) Insulator
120600	3/8” Greenfield (BX)
120800	1/4” In-Line Connector
120802	Red Butt Connector
120902	#74B Wire Nut
120903	Crimp-On Wire Nut
121014	1/4” Insulated (female) Terminal
121026	Tab Receptacle Combination
121499	5-1/2” Harness Tie
121500	8” Harness Tie
122503	Harness Tie Mounting Clip
122804	Manometer (water column test gauge)
121497	33” Heavy Duty Cable Tie
121507	Snap Wire Tie Screw Mount
182457	3/4” Jiffy Clip (BX Retainer Clip)
404500	Almond Brush-In-Cap Bottle Touch-Up Paint
404502	White Brush-In-Cap Bottle Touch-Up Paint
404506	Beige (Almond “B”) Brush-In-Cap Bottle Touch-Up Paint
404507	Cornflower Blue Brush-In-Cap Bottle Touch-Up Paint
880200	Electrical Terminal (assortment) Kit

