



AD-285

Parts Manual

Phase 7 / S.A.F.E. System

American Dryer Corporation

88 Currant Road, Fall River MA 02720-4781 USA
Telephone: +1 (269) 923-3000 / Fax: +1 (508) 678-9447
e-mail: mdl-service@whirlpool.com / www.adclaundry.com

Retain This Manual In A Safe Place For Future Reference

American Dryer Corporation products embody advanced concepts in engineering, design, and safety. If this product is properly maintained, it will provide many years of safe, efficient, and trouble free operation.

ONLY qualified technicians should service this equipment.

OBSERVE ALL SAFETY PRECAUTIONS displayed on the equipment or specified in the installation manual included with the dryer.

The following “**FOR YOUR SAFETY**” caution must be posted near the dryer in a prominent location.

FOR YOUR SAFETY

Do not store or use gasoline or other flammable vapors and liquids in the vicinity of this or any other appliance.

POUR VOTRE SÉCURITÉ

Ne pas entreposer ni utiliser d'essence ni d'autres vapeurs ou liquides inflammables à proximité de cet appareil ou de tout autre appareil.

We have tried to make this manual as complete as possible and hope you will find it useful. ADC reserves the right to make changes from time to time, without notice or obligation, in prices, specifications, colors, and material, and to change or discontinue models.

Important

For your convenience, log the following information:

DATE OF PURCHASE _____ MODEL NO. **AD-285**
RESELLER'S NAME _____
Serial Number(s) _____

Replacement parts can be obtained from your reseller or the ADC factory. When ordering replacement parts from the factory, you can FAX your order to ADC at +1 (508) 678-9447 or telephone your order directly to the ADC Parts Department at +1 (269) 923-3000. Please specify the dryer model number and serial number in addition to the description and part number, so that your order is processed accurately and promptly.

The illustrations on the following pages may not depict your particular dryer exactly. The illustrations are a composite of the various dryer models. Be sure to check the descriptions of the parts thoroughly before ordering.

“IMPORTANT NOTE TO PURCHASER”

Information must be obtained from your local gas supplier on the instructions to be followed if the user smells gas. These instructions must be posted in a prominent location near the dryer.

Table of Contents

Coin Control Door Assembly	4
Non-Coin Control Door Assembly	5
Phase 7 Coin Microprocessor Control Panel Assembly	6
Phase 7 Non-Coin Microprocessor Control Panel Assembly	7
Phase 7 Non-Coin Microprocessor Control Box Assembly	8
Dual Timer “Tap Touch” Controls	9
Non-Microprocessor Coin Meter Control Panel Assembly	10
Coin Meter Replacement Parts	11
Coin Vault Assembly	12
Main Door “Steel” Assembly	13
Main Door Switch Assembly	14
Front Panel Assembly	15
Lint Trap Assembly	16
Drop Lint Door Assembly	17
Tumbler / Support Assemblies	18
Tumbler Bearing Assembly	19
Idler Bearing Assembly	20
Motor Mount Assembly	21
Sensor Bracket Assemblies	22
Direct Spark Ignition Burner Assembly	24
Microprocessor Single-Phase (1Ø) Rear Electric Panel Assembly	26
Microprocessor 3-Phase (3Ø) Rear Electric Panel Assembly	27
Mechanical Timer Single-Phase (1Ø) Rear Electric Panel Assembly	28
Mechanical Timer 3-Phase (3Ø) Rear Electric Panel Assembly	29
Fire Suppression System Assembly for Models Mfd. as of November 8, 2011	30
Fire Suppression System Assemblies for Models Mfd. prior to November 8, 2011	31
Outer Top / Back Guard Assemblies	32
Additional Parts Available	33

Coin Control Door Assembly

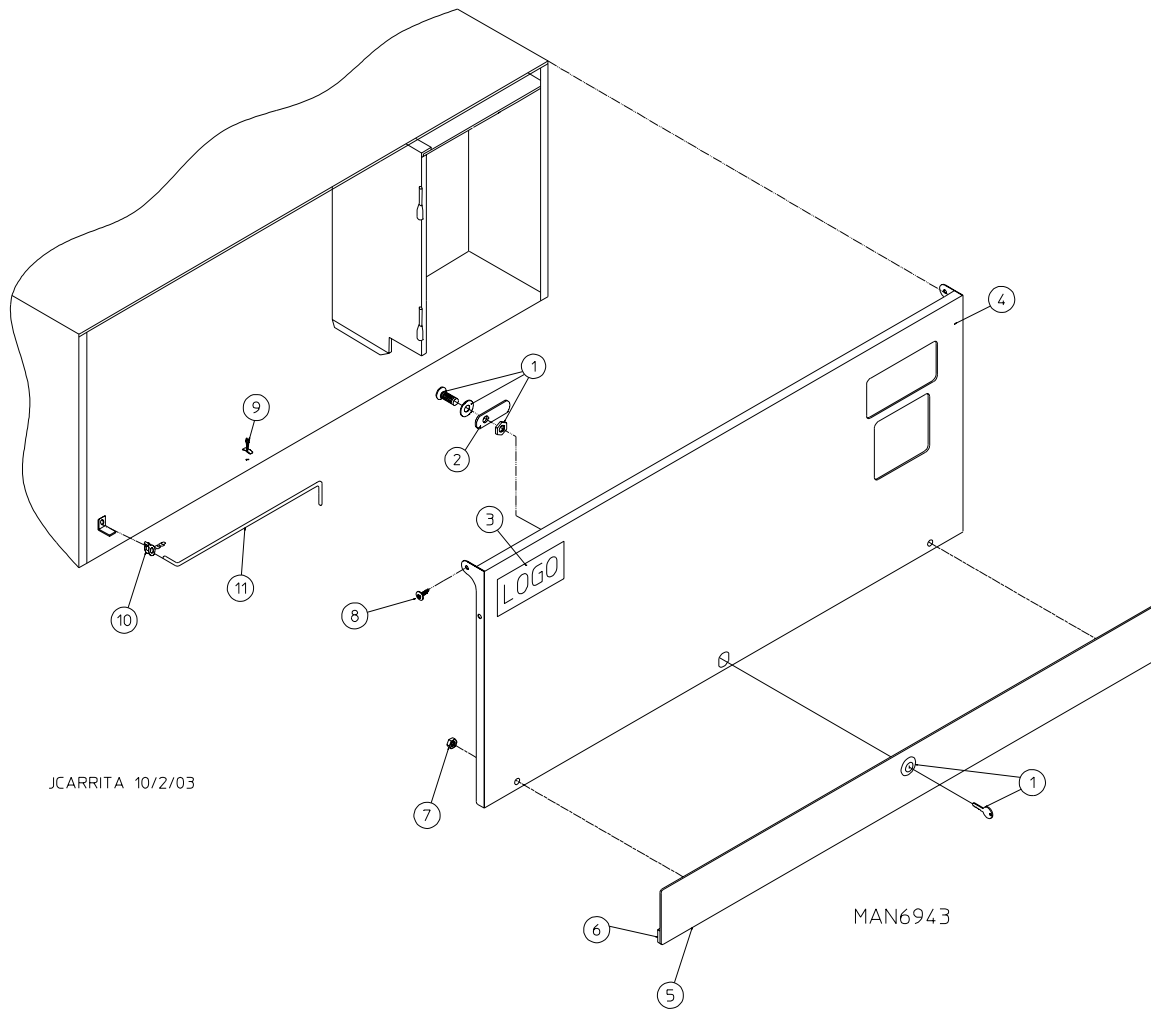

Illus. No.	Part No.	Qty.	Description
1	160015	1	High Security MK-100 Lock Assembly with Key
	160104	1	MK-100 Key Only
2	160032	1	Lock Cam Only
3	881053	1	ADC Logo with Tape
4*	823303	1	Control Door Assembly with Black Trim (includes illus. nos. 4 through 7) (for models mfd. as of June 7, 2011)
	823169	1	Control Door Assembly with Black Trim (includes illus. nos. 4 through 7) (for models mfd. prior to June 7, 2011)
5	817293	1	Black Trim (for models mfd. as of June 7, 2011)
	817194	1	Black Trim (for models mfd. prior to June 7, 2011)
6	117604	6	Neoprene Sponge Tape (sold by the foot)
7	152014	4	1/4-20 Free Spin Wash Nut (for models mfd. prior to June 7, 2011)
8	150317	2	#10-16 x 3/4" TORX® + BTN, Type 1
	150318	1	TORX® + Bit
9	102603	1	Control Door Support Rod Catch
10	102601	1	Control Door Rod Retainer Clip
11	102503	1	Control Door Support Rod

* Specify color.

Non-Coin Control Door Assembly

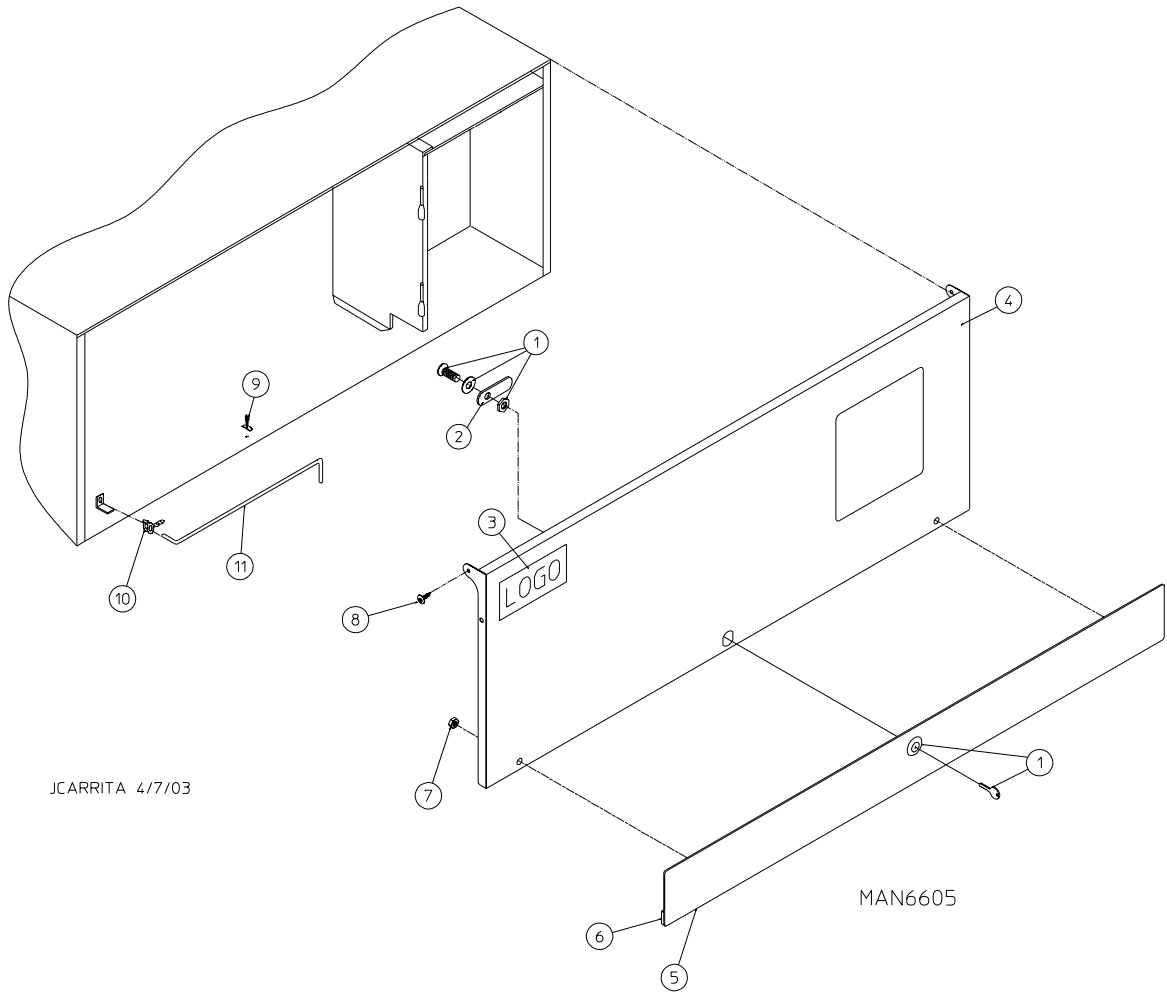

JCARRITA 4/7/03

MAN6605

Illus. No.	Part No.	Qty.	Description
1	160017	1	Control Door Lock (no key)
	160104	1	MK-100 Key Only
2	160032	1	Lock Cam Only
3	881053	1	ADC Logo with Tape
4*	817296	1	Control Door Assembly with Black Trim (includes illus. nos. 4 through 7) (for models mfd. as of June 7, 2011)
	817231	1	Control Door Assembly with Black Trim (includes illus. nos. 4 through 7) (for models mfd. prior to June 7, 2011)
5	817293	1	Black Trim (for models mfd. as of June 7, 2011)
	817194	1	Black Trim Strip with Lock Hole (for models mfd. prior to June 7, 2011)
6	117604	6	Noise Suppression Tape (sold by the foot)
7	152014	4	1/4-20 Free Spin Wash Nut (for models mfd. prior to June 7, 2011)
8	150317	2	#10-16 x 3/4" TORX® + Screw
	150318	1	TORX® + Bit (for removal of TORX® + Screw)
9	102603	1	Control Door Support Rod Catch
10	102601	1	Control Door Rod Retainer Clip
11	102503	1	Control Door Support Rod

* Specify color.

Phase 7 Coin Microprocessor Control Panel Assembly

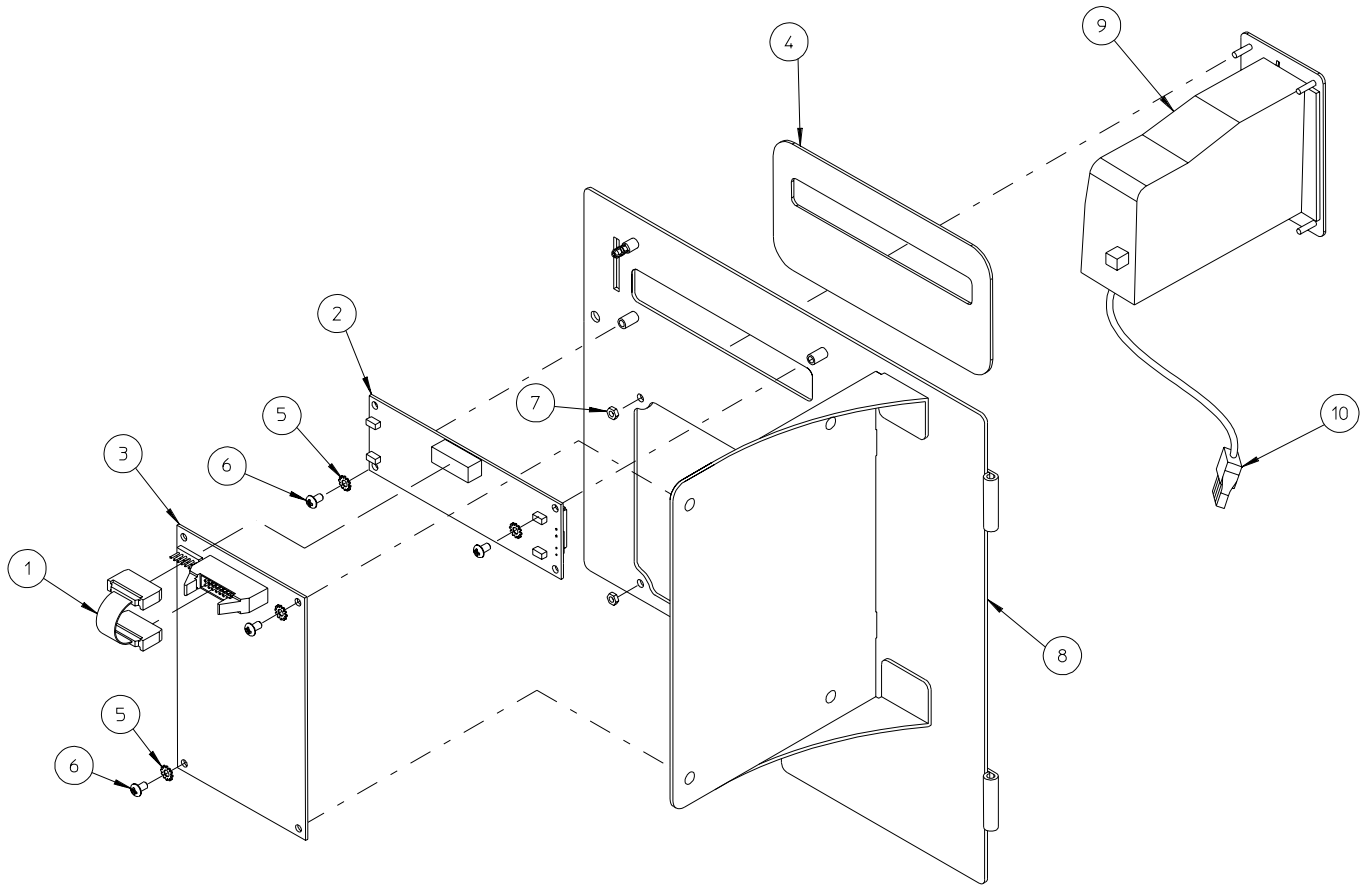

JCARRITA 10/17/02

MAN6308

<u>Illus. No.</u>	<u>Part No.</u>	<u>Qty.</u>	<u>Description</u>
1	137250	1	Phase 7 Coin Ribbon Cable
2	137270	1	16" x 1" Large Character Display
3	887007	1	Phase 7 Coin Board (for models without Sensor Activated Fire Extinguishing System)
	887009	1	Phase 7 Coin Board (for models with Sensor Activated Fire Extinguishing System)
4	112575	1	Phase 7 Keypad
5	153010	4	#6 Internal and External Star Washers
6	150005	4	#6-32 x 1/4" Phillips Round Head Machine Screw
7	152102	4	M3 Metric Hex Nut
8	814926	1	Phase 7 Coin Control Panel Only (for models mfd. as of May 11, 2011)
	823151	1	Phase 7 Coin Control Panel Only (includes illus. nos. 1 through 8) (for models mfd. prior to May 11, 2011)
9	803612	1	Phase 7 25¢ Coin Acceptor Assembly (for models mfd. as of May 11, 2011)
	818232	1	Phase 7 25¢ Coin Acceptor Assembly (for models mfd. prior to May 11, 2011)
10	122633	1	3-Pin Connector

Phase 7 Non-Coin Microprocessor Control Panel Assembly

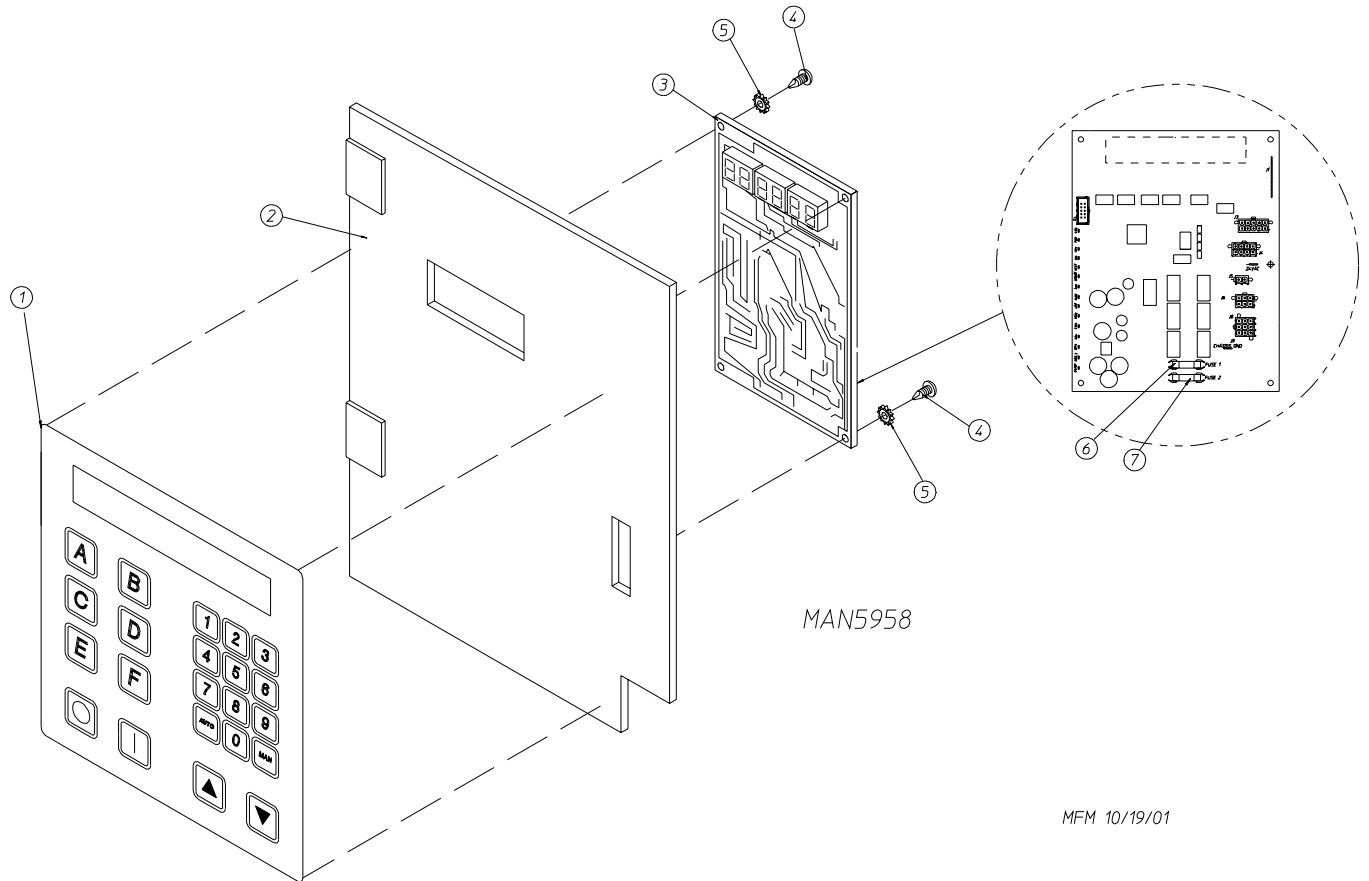

<u>Illus. No.</u>	<u>Part No.</u>	<u>Qty.</u>	<u>Description</u>
1	112571	1	Phase 7 Non-Coin Keypad
2	814932	1	Phase 7 Non-Coin Microprocessor Panel Only (for models mfd. as of May 11, 2011)
	850966	1	Phase 7 Non-Coin Microprocessor Panel Only (for models mfd. prior to May 11, 2011)
3	887000	1	Phase 7 Non-Coin Microprocessor with Sensor Activated Fire Extinguishing System
	887024	1	Phase 7 Non-Coin Microprocessor without Sensor Activated Fire Extinguishing System
4	150005	2	#6-32 x 3/4" Phillips Round Head Machine Screw
5	153010	2	#6 Star Washer
6	136016	1	5-Amp Fuse
7	136097	1	500 mA Fuse

Phase 7 Non-Coin Microprocessor Control Box Assembly

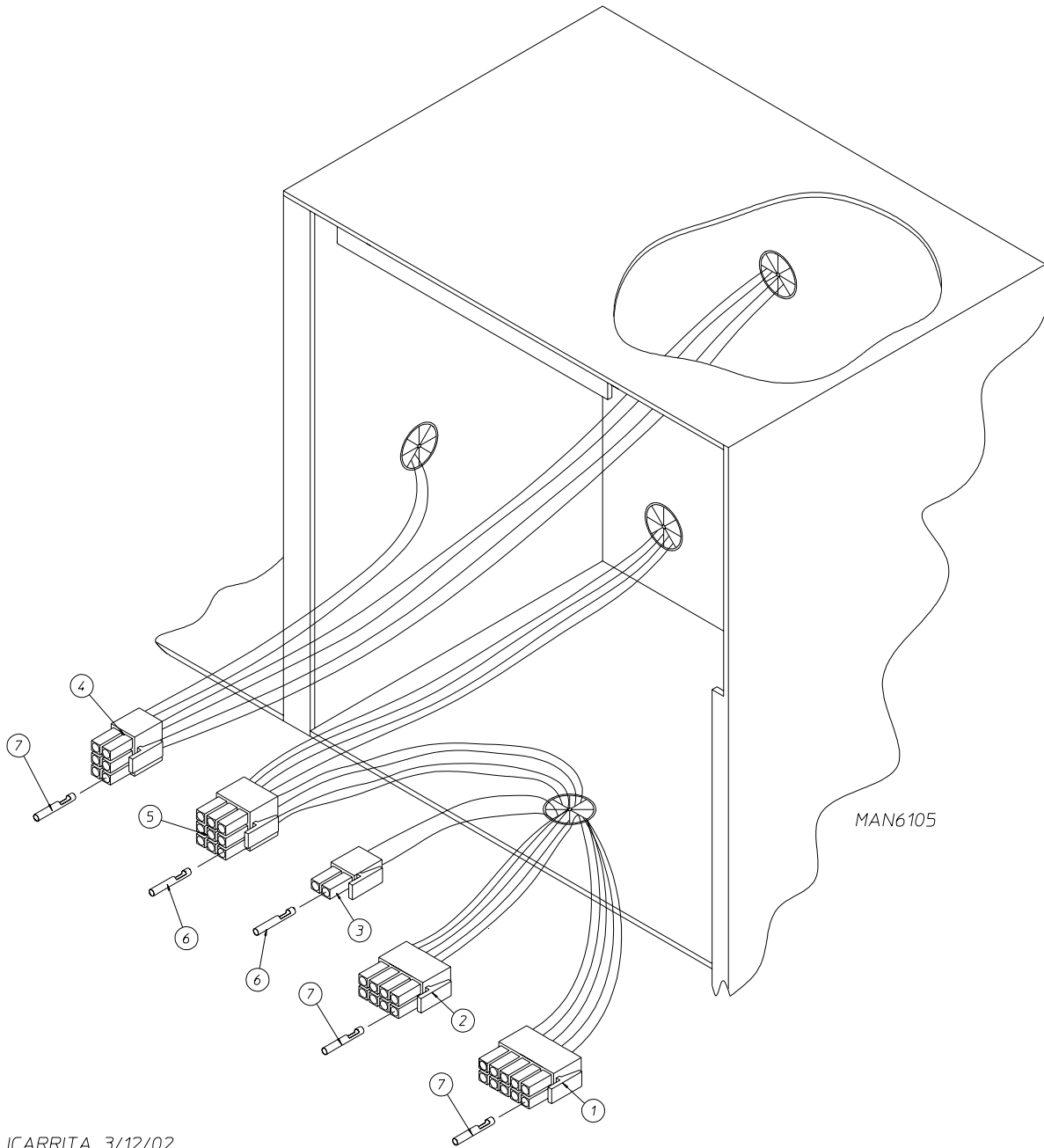

Illus. No.	Part No.	Qty.	Description
1	122681	1	10-Pin Connector
2	122676	1	8-Pin Connector
3	122646	1	2-Pin Connector
4	122683	1	6-Pin Connector
5	122640	1	9-Pin Connector
6	122706	*	#20-16 Socket
7	122669	*	Female Crimp Terminal

* As needed.

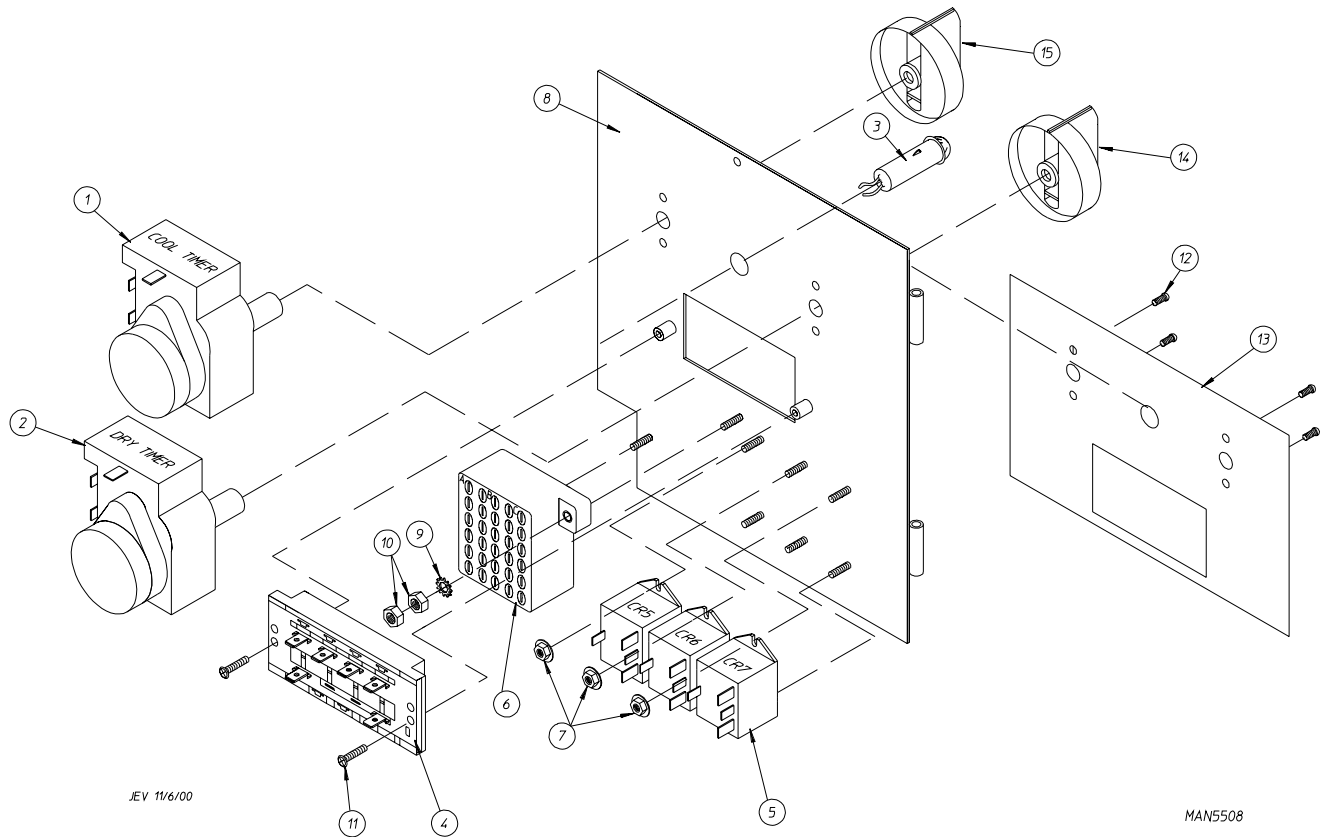

<u>Illus. No.</u>	<u>Part No.</u>	<u>Qty.</u>	<u>Description</u>
1	124030	1	15 Minute Timer – 24 VAC
2	124025	1	60 Minute Timer – 24 VAC
3	824175	1	Red Pilot Light – 24 VAC
4	122301	1	"Tap Touch" Switch
5	131932	3	Relay SPST 24v
6	120730	1	30-Position Terminal Block
7	151000	6	#6-32 Pal Nut
8	—	*	Dual Timer Panel Complete (includes illus. nos. 1 through 15)
	—	*	Dual Timer Panel Only
9	153010	2	#6 Star Washer
10	152000	3	#6-32 Hex Nut
11	150207	2	#10-24 x 1/2" Phillips Pan Head Machine Screw
12	150110	4	#8-32 x 1/4" Phillips Round Head Machine Screw
13	112563	1	Dual Timer Panel Overlay
14	124104	1	Pure Touch Knob with Red Pointer
15	124105	1	Pure Touch Knob with Blue Pointer

* Not available at time of printing. Consult factory for parts.

Non-Microprocessor Coin Meter Control Panel Assembly

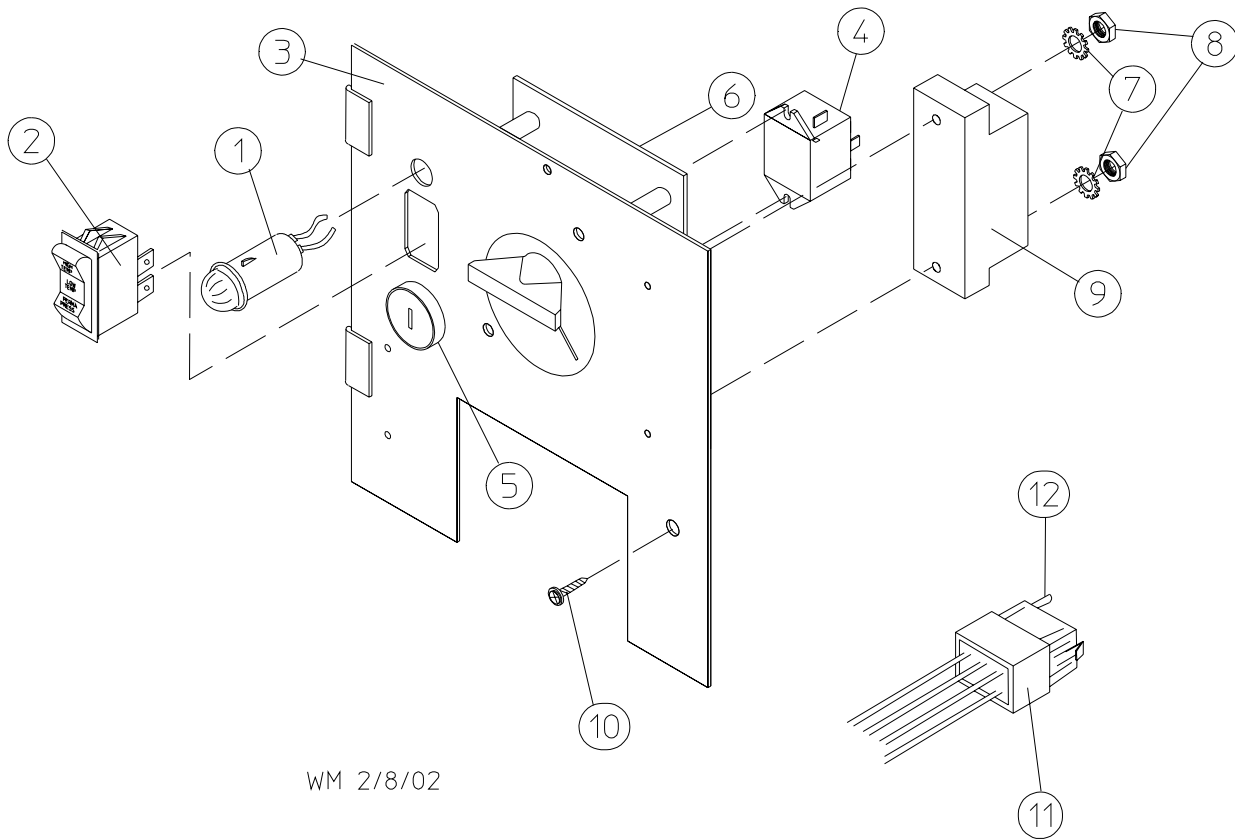

WM 2/8/02

MAN6086

<u>Illus. No.</u>	<u>Part No.</u>	<u>Qty.</u>	<u>Description</u>
1	123005	1	Red Indicator Light – 24 VAC
2	122400	1	Rocker Heat Selector Switch
3	883688	1	Coin Meter Control Panel Assembly Less Coin Meter (includes illus. nos. 2 through 5 and 7 through 9)
	883687	1	Coin Meter Control Panel Only
4	131932	1	24 VAC Relay
	154001	2	#10-24 Speed Nut (used on P/N: 131932, 24 VAC relay)
5	123225	1	Green Push-To-Start Button
6	125601	1	25¢ Coin Meter – 24 VAC (specify timing)
7	153010	2	#6 Star Washer
8	152016	2	#4-40 Hex Nut
9	120712	1	12-Position Terminal Block
10	150300	1	#10-16 x 1/2" Hex Washer TEK Screw
11	122602	1	9-Pin Connector
12	122700	7	Pin Terminal Only
	122801	1	Pin / Socket Extraction Tool ... Not Illustrated

NOTE: For Coin Meter Replacement Parts refer to page 11.

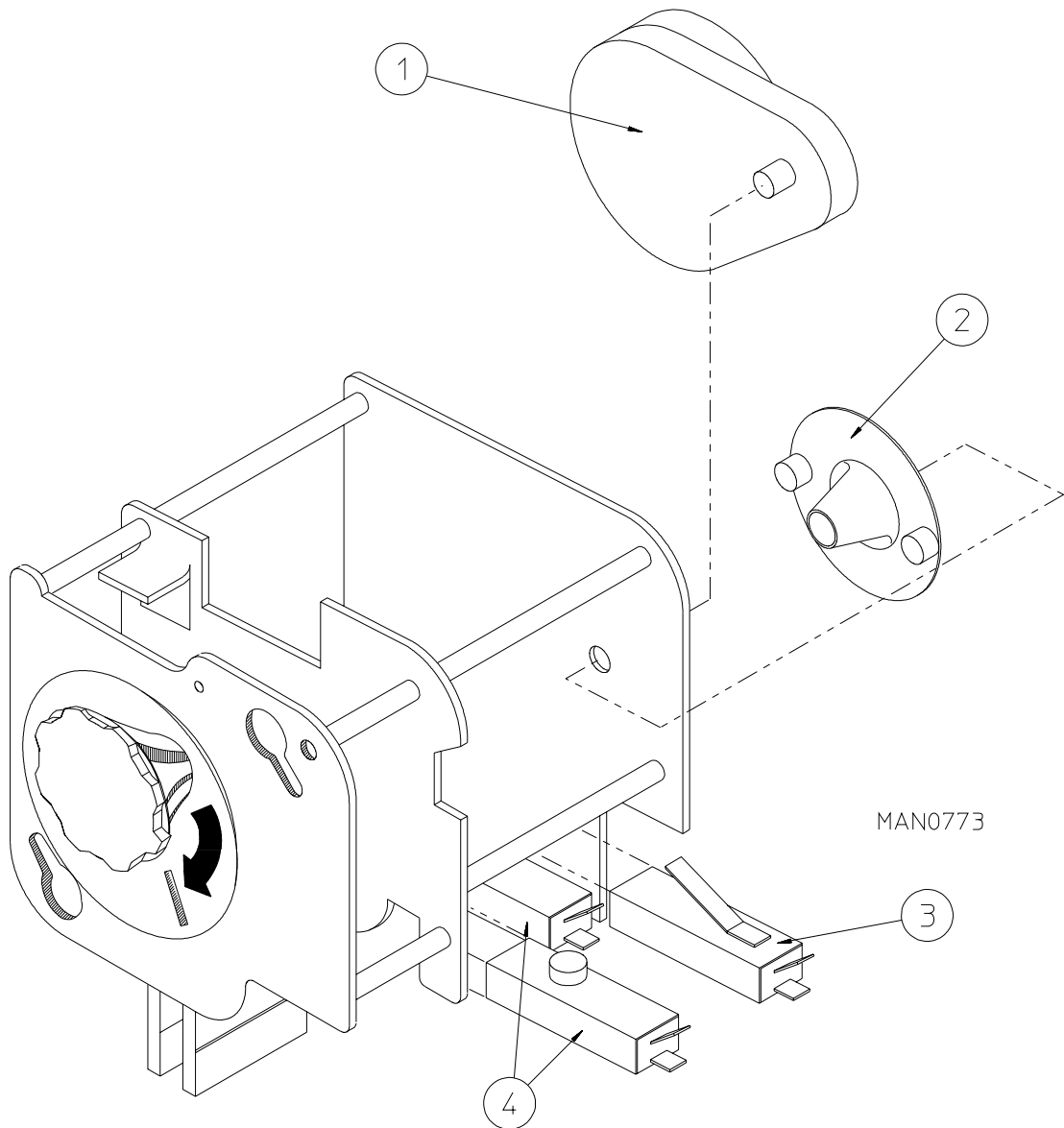

<u>Illus. No.</u>	<u>Part No.</u>	<u>Qty.</u>	<u>Description</u>
1	125541	1	1/60 RPM 24 VAC / 60 Hz Meter Motor
	125540	1	1/30 RPM 24 VAC / 50 Hz Meter Motor
2	125500	1	2-Point Cam
	125501	1	3-Point Cam
	125502	1	4-Point Cam
	125503	1	5-Point Cam
	125504	1	6-Point Cam
	125506	1	8-Point Cam
	125507	1	9-Point Cam
	125508	1	10-Point Cam
	125510	1	12-Point Cam
	3	125515	1
4	125516	2	Meter Switch "A" or "C"

Coin Vault Assembly

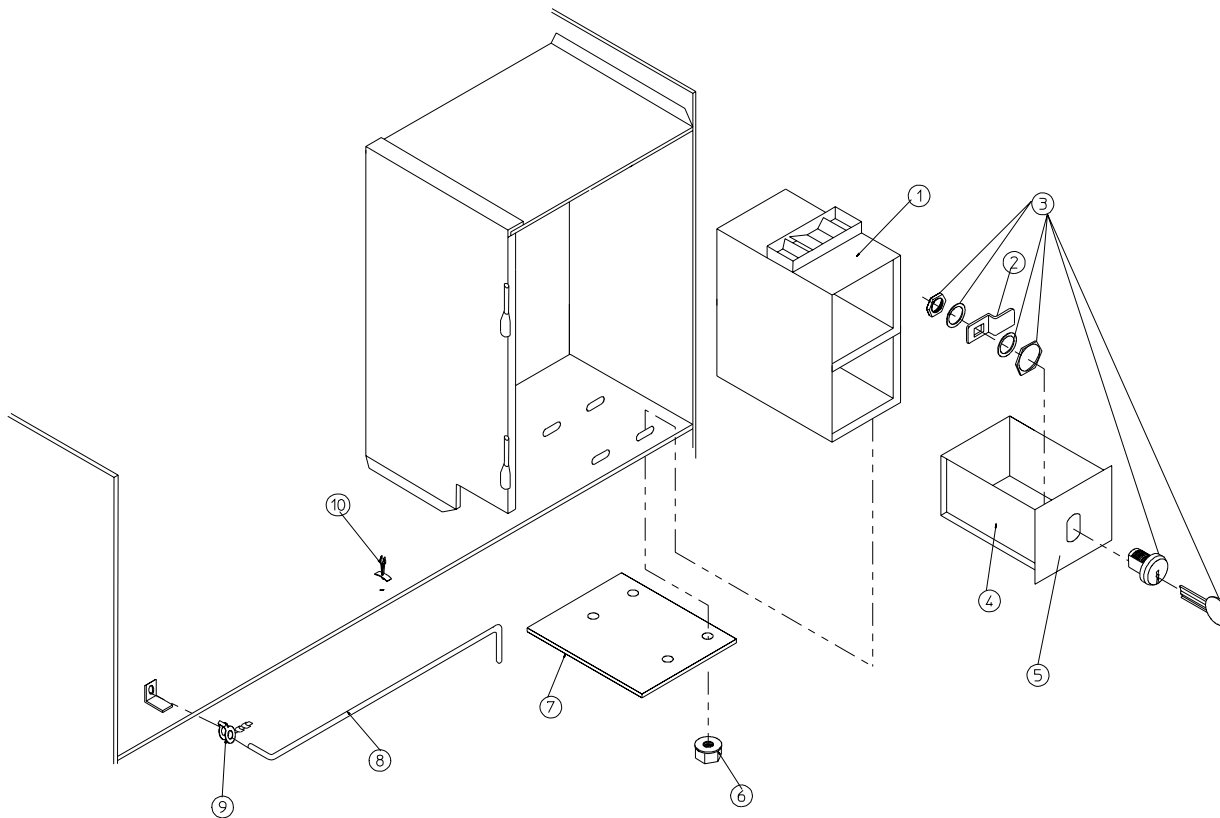

MAN0136

<u>Illus. No.</u>	<u>Part No.</u>	<u>Qty.</u>	<u>Description</u>
1	884037	1	Microprocessor Coin Vault Assembly Complete (includes illus. nos. 1 through 6)
	802130	1	Non-Microprocessor Coin Vault Assembly Complete (includes illus. nos. 1 through 6)
	823150	1	Microprocessor Coin Vault Only
	802120	1	Non-Microprocessor Coin Vault Only
2	160028	1	Cam for 1/4-Turn Lock Only
3	875061	1	1/4-Turn Lock Assembly (includes illus. nos. 2 and 3)
	160007	1	1/4-Turn Lock with Key Only
	160105*	1	1/4-Turn Mer-Pel Key Only
4	802020	1	1/4-Turn Coin Box Assembly (includes illus. nos. 2 through 5)
	802019	1	1/4-Turn Coin Box Only without Faceplate
5	802018	1	1/4-Turn Coin Box Faceplate Only
6	152014	4	1/4-20 Free Spin Wash Nut
7	309250	1	Coin Vault Slot Cover
8	102503	1	Control Door Support Rod
9	102601	1	Control Door Rod Retainer Clip
10	102603	1	Control Door Support Rod Catch

* Specify key number when ordering.

Main Door "Steel" Assembly

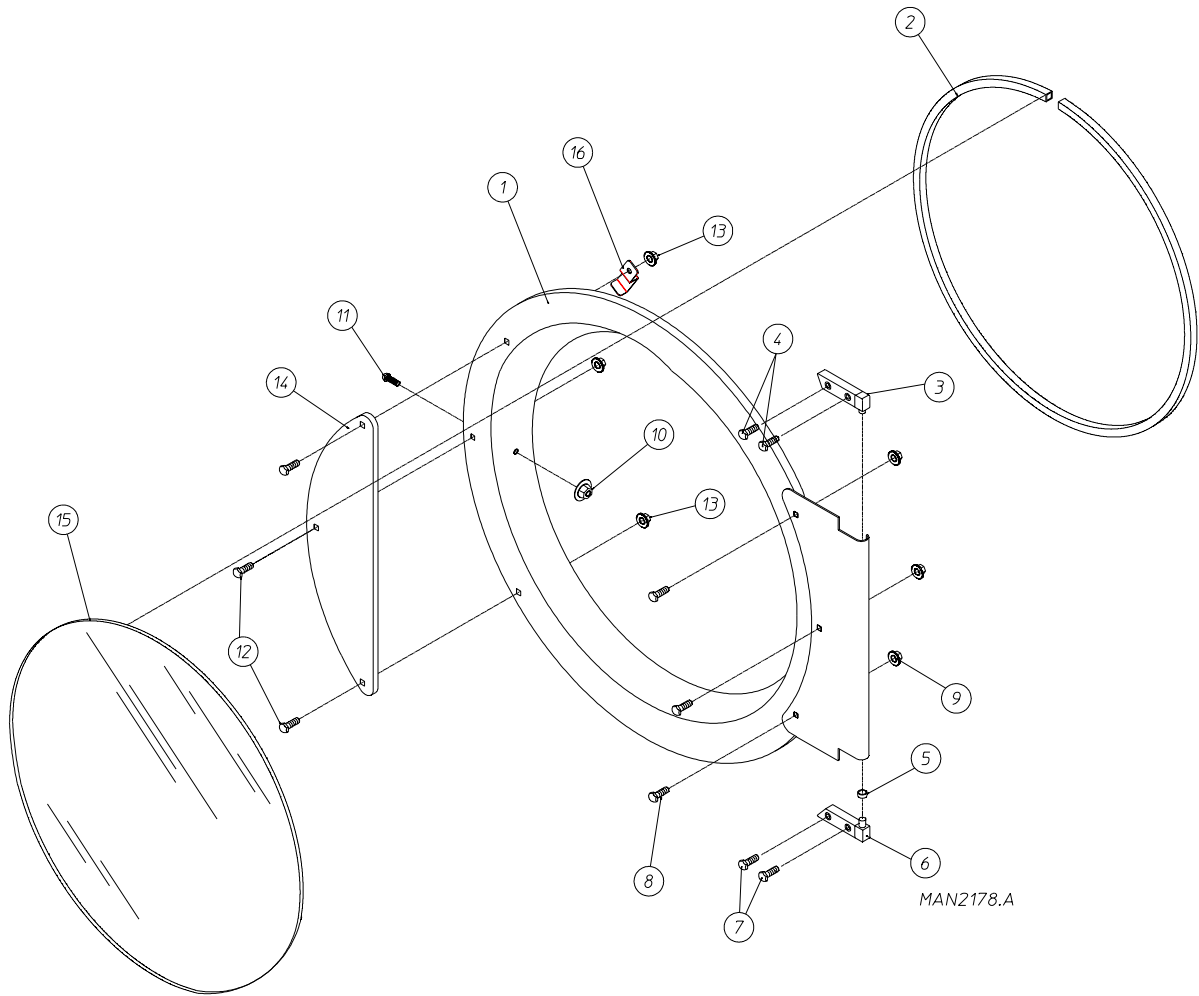

<u>Illus. No.</u>	<u>Part No.</u>	<u>Qty.</u>	<u>Description</u>
1	822661	1	Magnet Black Main Door Assembly Complete (includes illus. nos. 1, 2, 8, 9, and 12 through 16)
	881150	1	Latch Black Main Door Assembly Complete (includes illus. nos. 1, 2, 8, and 9 through 15)
2	102354	1	Door Gasket
	401010	1	Mastic Adhesive (5 oz. tube)
3	881152	1	Black Top Hinge Block Assembly (includes illus. nos. 3 and 4)
4	150445	2	1/4-20 x 3/4" Black Cap Head Setscrew
5	153031	1	1/4" Nylon Washer
6	881151	1	Black Bottom Hinge Block Assembly (includes illus. nos. 5 through 7)
7	150445	2	1/4-20 x 3/4" Black Cap Head Setscrew
8	150683	3	1/4-20 x 5/8" Black Carriage Bolt
9	152014	3	1/4-20 Free Spin Wash Nut
10	151010	1	#10-32 Black Hex Acorn Nut (latch models Only)
11	150125	1	Door Screw (latch models Only)
12	150683	3	1/4-20 x 5/8" Black Carriage Bolt
13	152014	3	1/4-20 Free Spin Wash Nut
14	881210	1	Black Main Door Handle Only
15	102211	1	20-7/16" Door Glass
	401039	1	Adhesive (10.3 oz. cartridge)
16	319298	2	Magnet Bracket

Main Door Switch Assembly

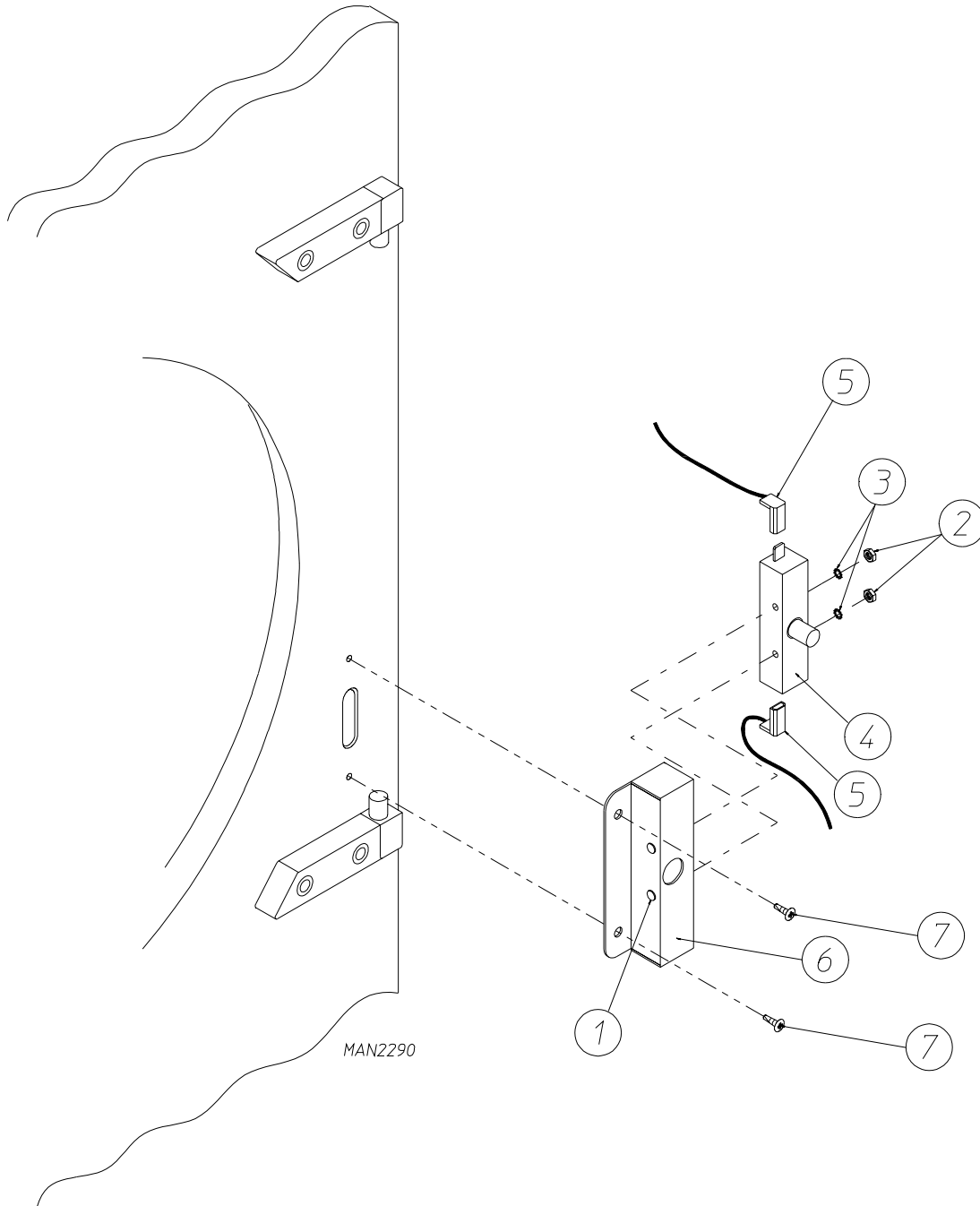

Illus. No.	Part No.	Qty.	Description
1	150006	2	#6-32 x 7/8" Clinch Stud
2	152013	2	#6-32 Hex Nut
3	153010	2	#6 Star Washer
4	137005	1	Door Switch
5	122636	2	Flag Terminal
6	881211	1	Black Main Door Switch Housing Only
	881153	1	Black Main Door Switch Housing Complete (includes illus. nos. 1 through 4 and 6)
7	150301	2	#8-18 x 7/16" Phillips Pan Head TEK Screw

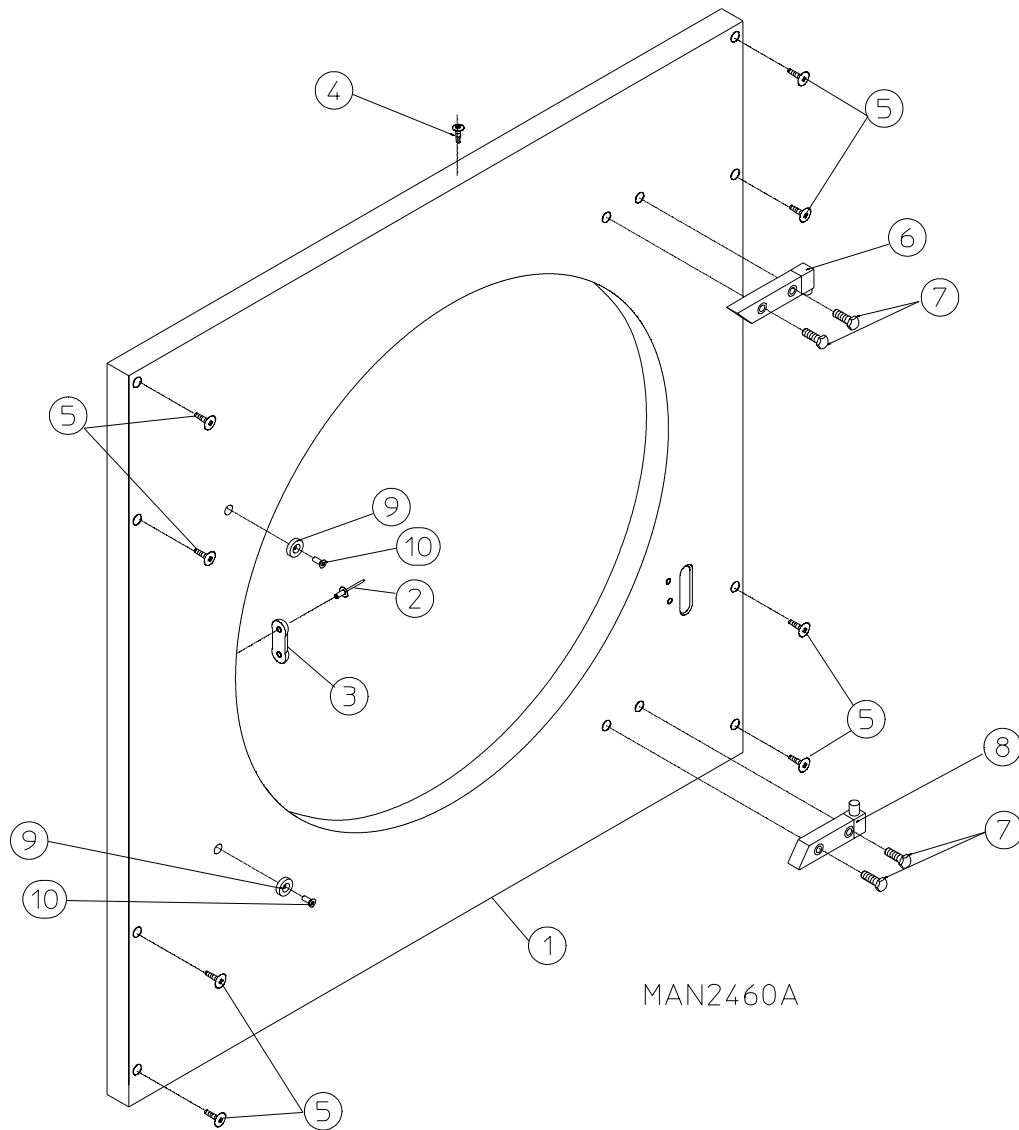

MAN2460A

Illus. No.	Part No.	Qty.	Description
1	822667*	1	Front Panel Assembly with Magnets (includes illus. nos. 1 through 3)
	883816	1	White Front Panel Assembly with Latch (includes illus. nos. 1 through 3)
	883817	1	Ivory Front Panel Assembly with Latch (includes illus. nos. 1 through 3)
	883818	1	Coral Blue Front Panel Assembly with Latch (includes illus. nos. 1 through 3)
2	154215	2	1/8" Pop Rivet
3	881987	1	Friction Door Latch (includes illus. nos. 2 and 3)
4	150300	1	#10-16 x 1/2" Hex Washer TEK Screw
5	150309	8	#10-16 x 1/2" Hex Head TEK Crimptite Screw
6	881152	1	Black Top Hinge Block Assembly
7	150445	4	1/4-20 x 7/8" Black Cap Head Setscrew
8	881151	1	Black Bottom Hinge Block Assembly
9	102004	2	Door Magnet
10	152223	2	T-20 TORX® Screw

* Specify color.

Lint Trap Assembly

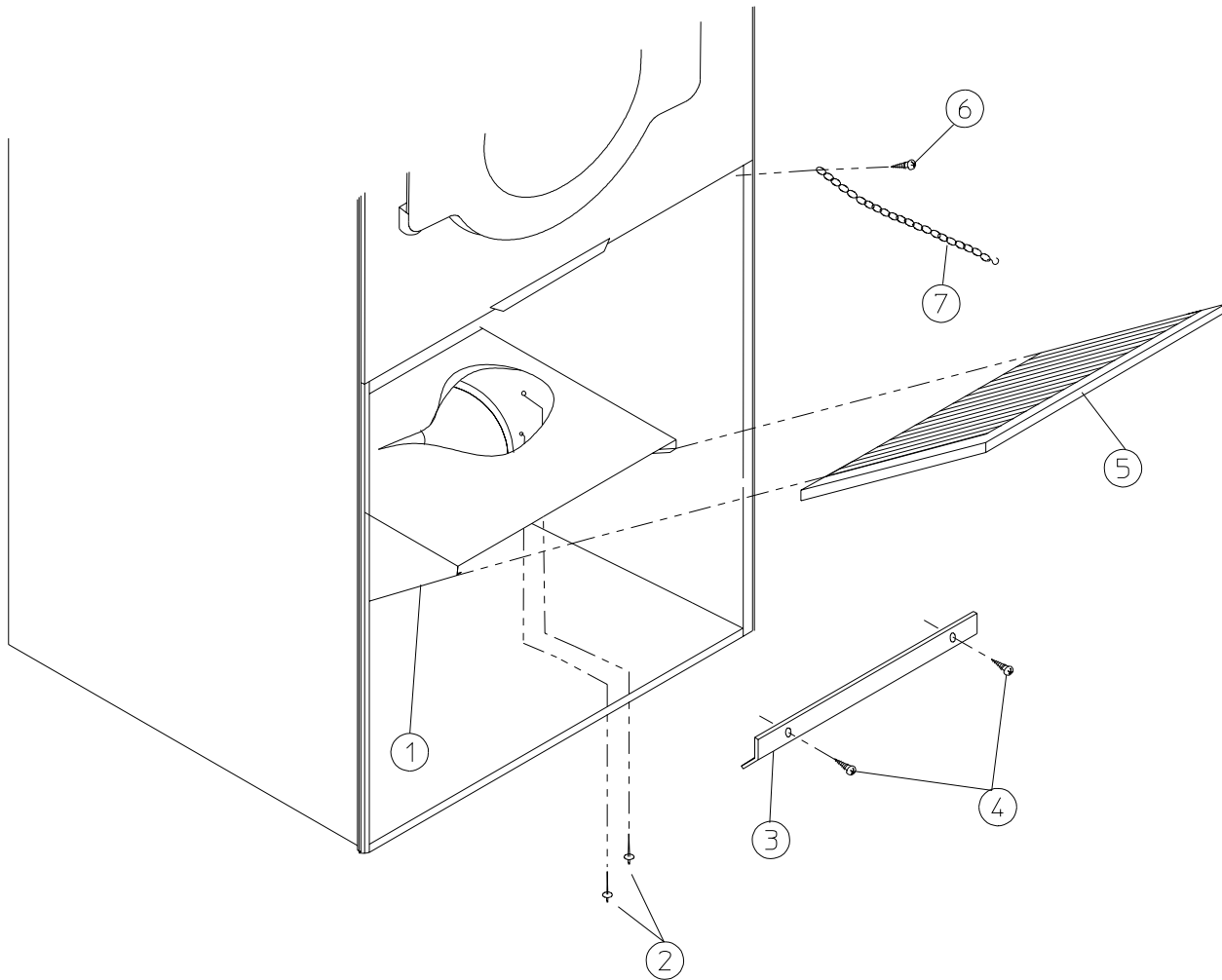

MAN0107

Illus. No.	Part No.	Qty.	Description
1	800410	1	Lint Trap Assembly Complete (includes illus. nos. 1 and 3 through 5)
	800411	1	Lint Trap Only
2	154200	7	5/32" Pop Rivet
3	304102	1	Lint Screen Holder
4	150300	3	#10-16 x 1/2" Hex Washer TEK Screw
5	800503	1	Lint Screen
6	150419	2	#6 x 1/2" Tamperproof TEK Screw
7	108120	1	Chain for Drop Lint Door (10-1/2" length)
	150418	1	Tamperproof Screw Hand Driver

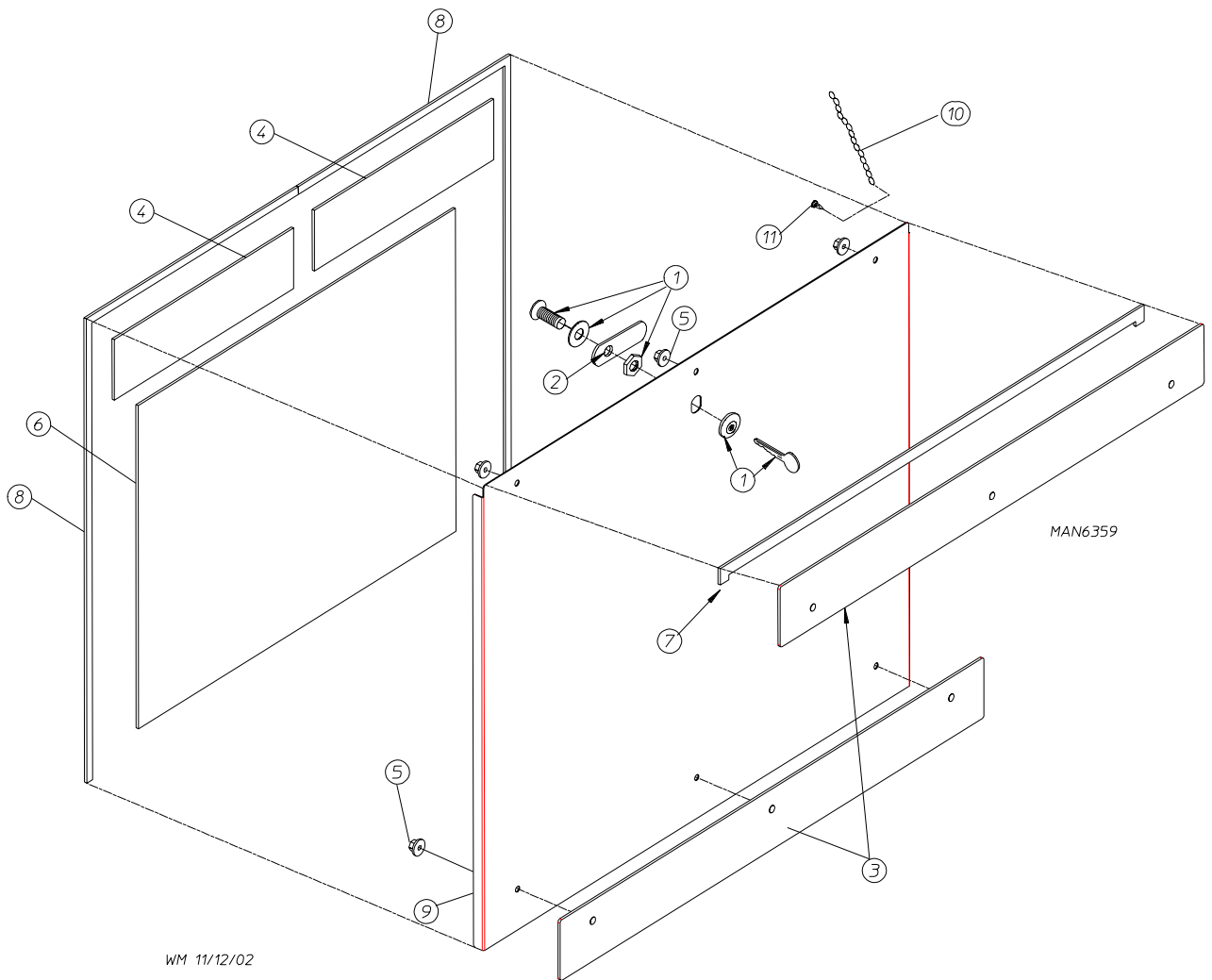

Illus. No.	Part No.	Qty.	Description
1	160001	1	AD-100 Lock Assembly with Key
	160103	1	AD-100 Key Only
	800150	1	Knob Latch Kit Assembly with Cam
	157000	1	Spring for Knob Latch Assembly
	2	160016	1
	160009	1	Knob Latch Adjustable Cam Only
	150425	1	#12-24 x 3/8" Round Head Machine Screw (screw for knob latch adjustable cam)
	3	883623	2
4	116256	2	Top Lint Door Insulation
5	152014	6	1/4-20 Free Spin Wash Nut
6	116176	1	Lint Door Insulation
7	117603	3	Suppression Tape / Gasket (sold by the foot)
8	117604	7	Neoprene Sponge Tape (sold by the foot)
9	883691	1	White Drop Lint Door Assembly (includes illus. nos. 3 through 9)
	883693	1	Ivory Drop Lint Door Assembly (includes illus. nos. 3 through 9)
	883692	1	Coral Blue Drop Lint Door Assembly (includes illus. nos. 3 through 9)
10	108120	1	Chain for Drop Lint Door
11	150419	2	#6 x 1/2" Tamperproof TEK Screw
	150418	1	Tamperproof Screw Hand Driver

Tumbler / Support Assemblies

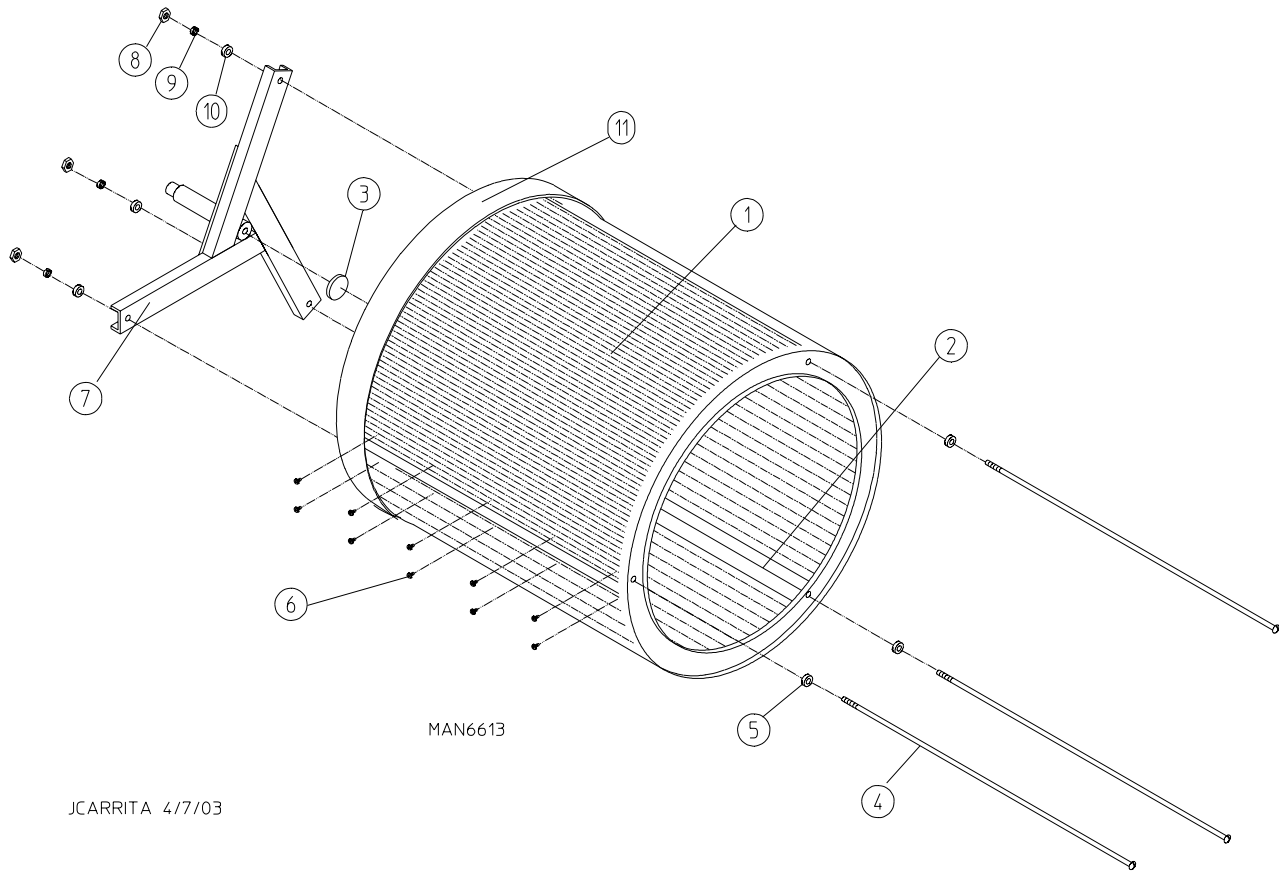

Illus. No.	Part No.	Qty.	Description
1	800830	1	Tumbler and Support Assembly Complete with Felt Collar (includes illus. nos. 1 through 11)
	800890	1	Stainless Steel Tumbler and Support Assembly Complete with Felt Collar (includes illus. nos. 1 through 11)
	800720*	1	Tumbler Only without Felt Collar (includes illus. nos. 1, 2, and 6)
	800840*	1	Stainless Steel Tumbler Only without Felt Collar (includes illus. nos. 1, 2, and 6)
2	301315	2	Tumbler Rib (short)
	301316	1	Tumbler Rib (tall)
	301414	2	Stainless Steel (short) Tumbler Rib
	301415	1	Stainless Steel (tall) Tumbler Rib
3	115986	1	1/4" x 2" Felt Tumbler Pad
4	100915	3	3/8-16 x 31" Tie Rod
5	153004	3	3/8" Flat Washer
6	150313	30	#10-16 x 1/2" TORX® + BTN Type I (for models mfd. as of April 7, 2011)
	154210	30	Pop Rivet (for models mfd. prior to April 7, 2011)
7	800612	1	Tumbler Support
8	152027	3	3/8-16 Hex Nut
9	153005	3	3/8" Lock Washer
10	153004	3	3/8" Flat Washer
11	116003	1	Felt Collar Only
—	401010	1	#847 Adhesive for Felt Collar and Tumbler Pad (5 oz. tube)

* Felt collar is not included and must be ordered separately.

Tumbler Bearing Assembly

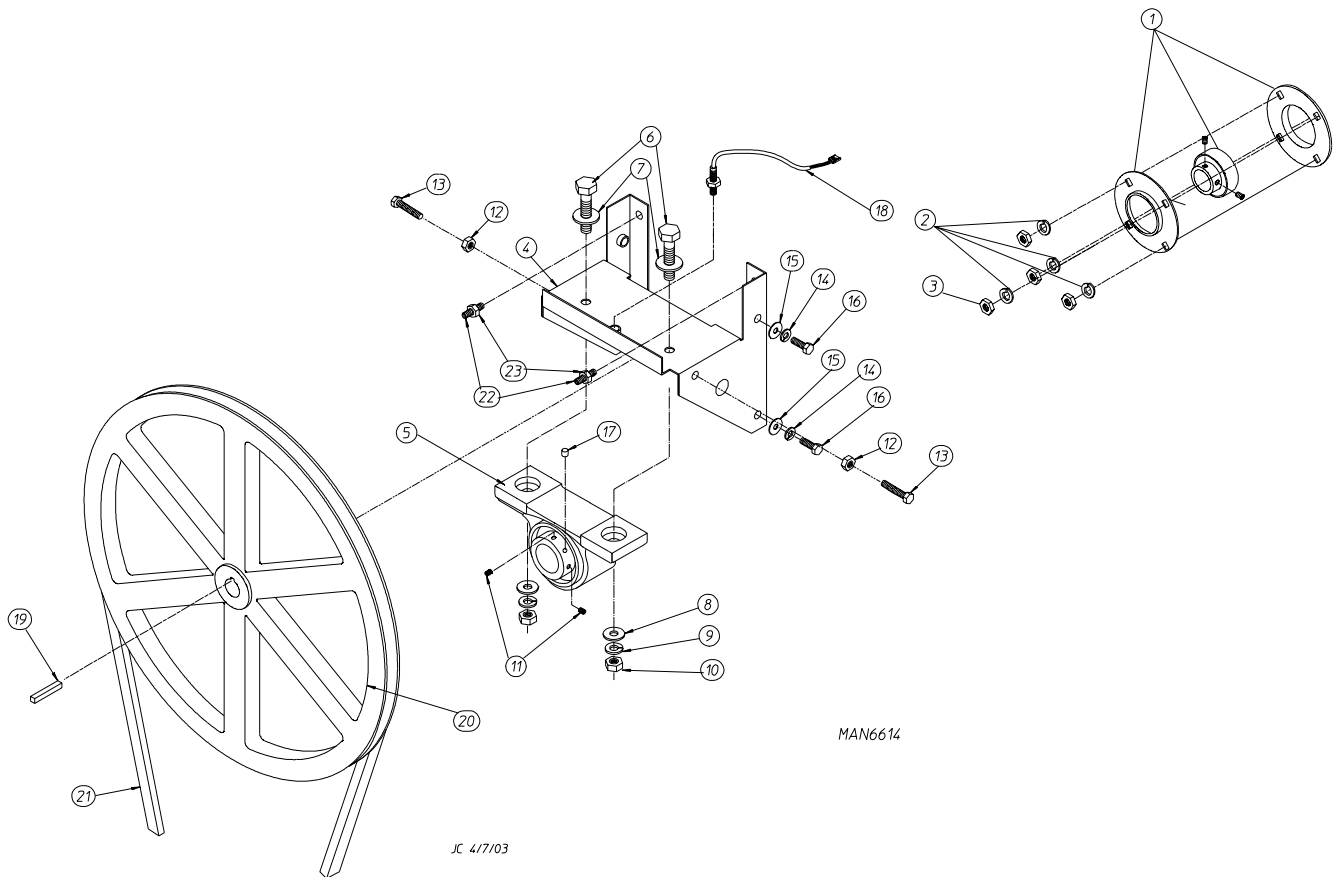

<u>Illus. No.</u>	<u>Part No.</u>	<u>Qty.</u>	<u>Description</u>
1	880209	1	1-3/8" Flange Bearing
2	153005	4	3/8" Lock Washer
3	152005	4	3/8-16 Hex Nut
4	883387	1	Pillow Block Bearing Assembly Complete (for micro models Only) (includes illus. nos. 4 through 18, 22, and 23)
	882544	1	Pillow Block Bearing Assembly Complete (for dual timer models Only) (includes illus. nos. 4 through 16, 22, and 23)
	882543	1	Pillow Block Bearing Platform Only (for micro models Only)
	882542	1	Pillow Block Bearing Platform Only (for dual timer models Only)
5	880779	1	1-3/8" Pillow Block Bearing (for micro models Only)
	880202	1	1-3/8" Pillow Block Bearing (for dual timer models Only)
6	150601	2	3/8-16 x 2" Hex Bolt
7	153004	2	3/8" Flat Washer
8	153004	2	3/8" Flat Washer
9	153005	2	3/8" Lock Washer
10	152005	2	3/8-16 Hex Nut
11	154326	2	5/16-24 x 3/8" Setscrew
12	152004	2	5/16-18 Hex Nut
13	150621	2	5/16-18 x 1-1/2" Tap Bolt
14	153002	4	5/16" Lock Washer
15	153004	6	3/8" Flat Washer
16	150501	4	5/16-18 x 3/4" Tap Bolt
17	102120	1	Sintered 8 Magnet (for micro models Only)
18	883386	1	Rotational Sensor Assembly (for micro models Only)
19	100713	1	Shaft Key
20	101100	1	18" Pulley
21	100111	1	5L-650 V-Belt (tumbler to idler)
22	150610	2	5/16-18 x 1-1/2" Allen Setscrew
23	152004	2	5/16-18 Hex Nut

Idler Bearing Assembly

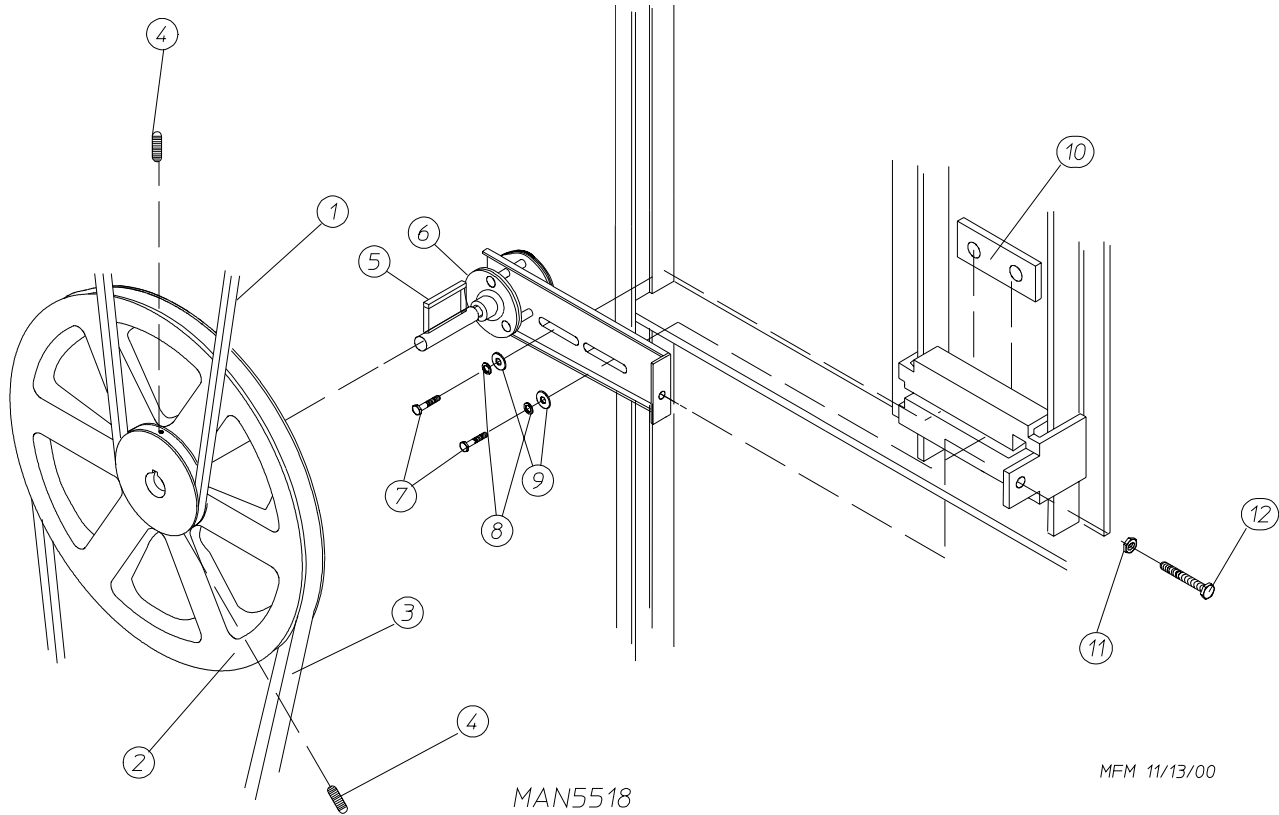

Illus. No.	Part No.	Qty.	Description
1	100111	1	5L-650 V-Belt (idler to tumbler)
2	101129	1	9" x 2-1/2" Compound Pulley
3	100105	1	4L-520 V-Belt (idler to motor)
4	154301	2	5/16-18 x 1" Allen Setscrew
5	100705	1	3/16" x 3/16" x 1-3/8" Key
6	882776	1	Idler Bearing Assembly Complete (includes illus. nos. 5 through 12)
7	150617	2	3/8-16 x 1" Hex Head Machine Bolt
8	153005	2	3/8" Lock Washer
9	153004	2	3/8" Flat Washer
10	801009	1	Idler Square Washer
11	152004	1	5/16-18 Hex Nut
12	150509	1	5/16-18 x 3" Hex Head Machine Bolt

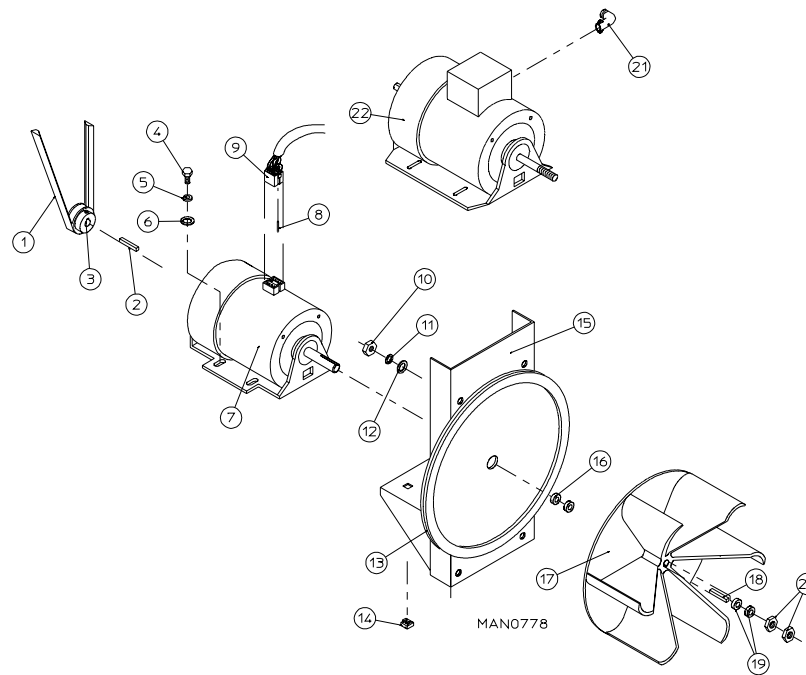

Illus. No.	Part No.	Qty.	Description
1	100105	1	4L-520 V-Belt (to idler assembly)
2	100701	1	3/16" x 3/16" x 1" Key (for use on 3ø models Only)
3	101131	1	1/2" x 2-1/4" Motor Pulley (for use on 1ø – 60 Hz motors Only)
	101133	1	5/8" x 2-1/4" Motor Pulley (for use on 3ø – 60 Hz motors Only)
	101125	1	1/2" x 2-1/2" Motor Pulley (for use on 1ø – 50 Hz motors Only)
	101130	1	5/8" x 2-1/2" Motor Pulley (for use on 3ø – 50 Hz motors Only)
4	150501	4	5/16-18 x 3/4" Hex Head Machine Bolt
5	153002	4	5/16" Lock Washer
6	153001	4	5/16" Flat Washer
7	181049	1	1/2 hp 100-230v 50/60 Hz Motor with Plug
8	122701	8	Socket Terminal Only
	122801	1	Pin / Socket Extraction Tool ... Not Illustrated
9	137030	1	8-Pin Housing Connector
10	152004	4	5/16-18 Hex Nut
11	153002	4	5/16" Lock Washer
12	153001	4	5/16" Flat Washer
13	117600	4	Noise Suppression Tape (sold by the foot)
14	154000	4	5/16-18 Nut
15	800909	1	1/2 hp Motor Mount Only (56Z frame)
	803966	1	1/2 hp 115-230v (1ø) 60 Hz Motor Mount Assembly with Plug (includes illus. nos. 3 through 7 and 13 through 20)
	803965*	1	1/2 hp 208/230/380/460v (3ø) 60 Hz Totally Enclosed, Fan-Cooled Motor Mount Assembly Complete (includes illus. nos. 2 through 6 and 13 through 22)
	803939	1	1/2 hp 240v (1ø) 50 Hz Motor Mount Assembly with Plug (includes illus. nos. 3 through 7 and 13 through 20)
	803792*	1	1/2 hp 208/230/380/460v (3ø) 50 Hz Totally Enclosed, Fan-Cooled Motor Mount Assembly Complete (includes illus. nos. 2 through 6 and 13 through 22)
16	153050	2	1/2" S.A.E. Flat Washer
17	100604	1	12-1/2" Impellor (fan / blower) with 1/2" Bore
18	100702	1	1/8" x 1/8" x 1-1/2" Key
19	153050	2	1/2" S.A.E. Flat Washer
20	152006	2	1/2-20 Left-Hand Jam Nut
21	120200	1	3/8" x 90° Connector
22	100007*	1	1/2 hp 208/230/380/460v (3ø) 50/60 Hz Totally Enclosed, Fan-Cooled Motor (56Z frame)

* Specify voltage when ordering.

Sensor Bracket Assemblies

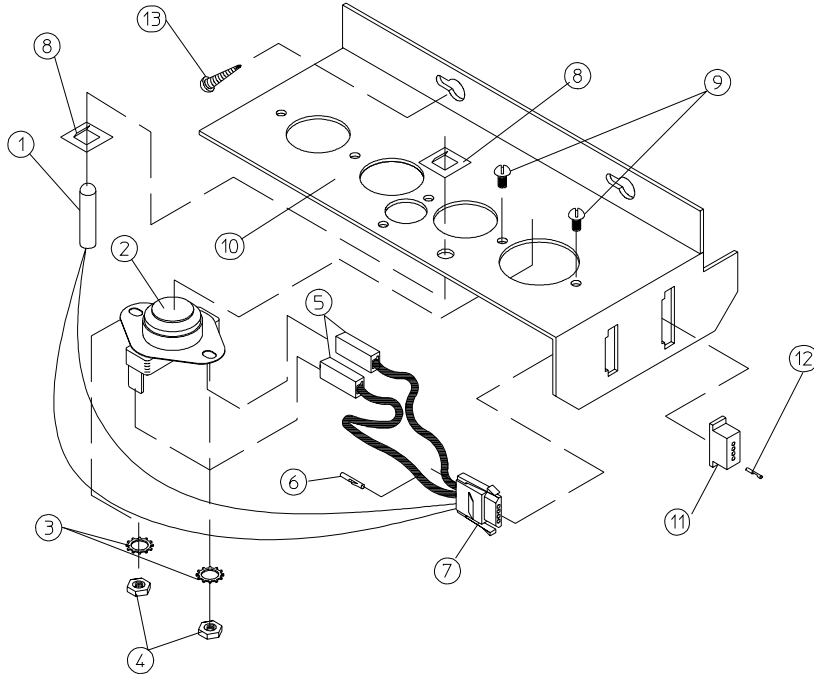

MICROPROCESSOR SENSOR BRACKET ASSEMBLY

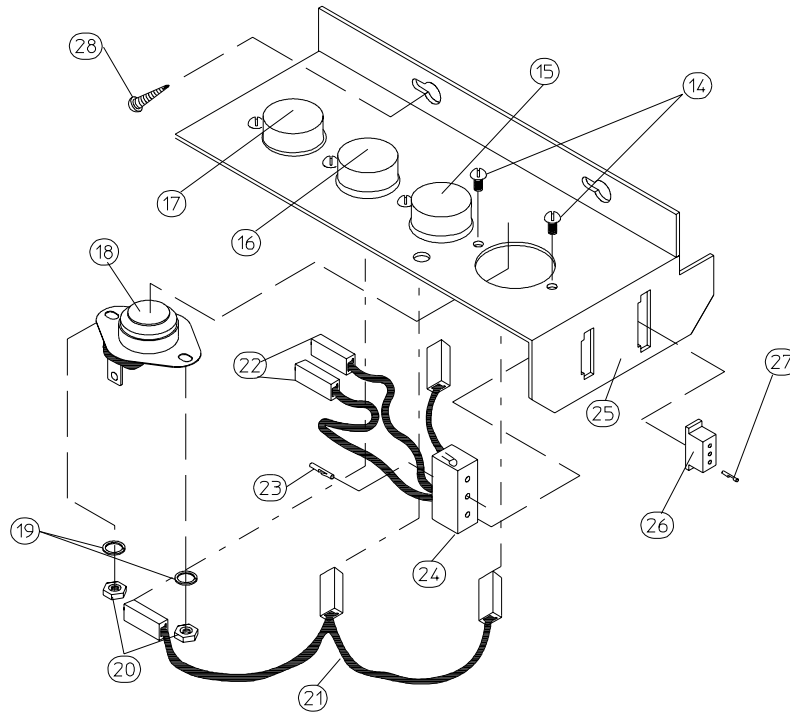

NON-COMPUTER SENSOR BRACKET ASSEMBLY

MAN0238

<u>Illus. No.</u>	<u>Part No.</u>	<u>Qty.</u>	<u>Description</u>
1	880251	1	1/4" Temperature Sensor Probe Assembly (includes illus. nos. 1 and 5 through 8)
2	130103	1	225° High-Limit Thermostat
3	153010	2	#6 Star Washer
4	152000	2	#6-32 Hex Nut
5	121028	2	Insulated Terminal
6	122701	4	Socket Terminal
7	122605	1	4-Pin Connector (female)
8	154007	2	1/4" Push-On Fastener
9	150005	2	#6-32 x 1/4" Round Head Machine Screw
10	801425	1	Microprocessor Sensor Bracket Assembly Complete (includes illus. nos. 1 through 10)
	305007	1	Universal Sensor Bracket Only
11	122604	1	4-Pin Connector (male)
12	122700	4	Pin Terminal
13	150301	2	#8-18 x 7/16" Phillips Pan Head TEK Screw
14	150000	5	#6-32 x 1/4" Slotted Round Head Machine Screw
15	130111	1	130° Large Thermostat
16	130100	1	150° Large Thermostat
17	130103	1	225° High-Limit Thermostat
18	130101	1	180° Large Thermostat
19	153010	5	#6 Star Washer
20	152000	5	#6-32 Hex Nut
21	840065	1	Sensor Jumper
22	121028	4	Insulated Terminal
23	122701	4	Socket Terminal
24	122605	1	4-Pin Connector (female)
	840062	1	Sensor Bracket Harness Assembly (includes illus. nos. 22 through 24)
25	801418	1	Noncomputer Sensor Bracket Assembly Complete (includes illus. nos. 14 through 25)
	305007	1	Universal Sensor Bracket Only
26	122604	1	4-Pin Connector (male)
27	122700	4	Pin Terminal
	122801	1	Pin / Socket Extraction Tool ... Not Illustrated
28	150301	2	#8-18 x 7/16" Phillips Pan Head TEK Screw

Direct Spark Ignition Burner Assembly

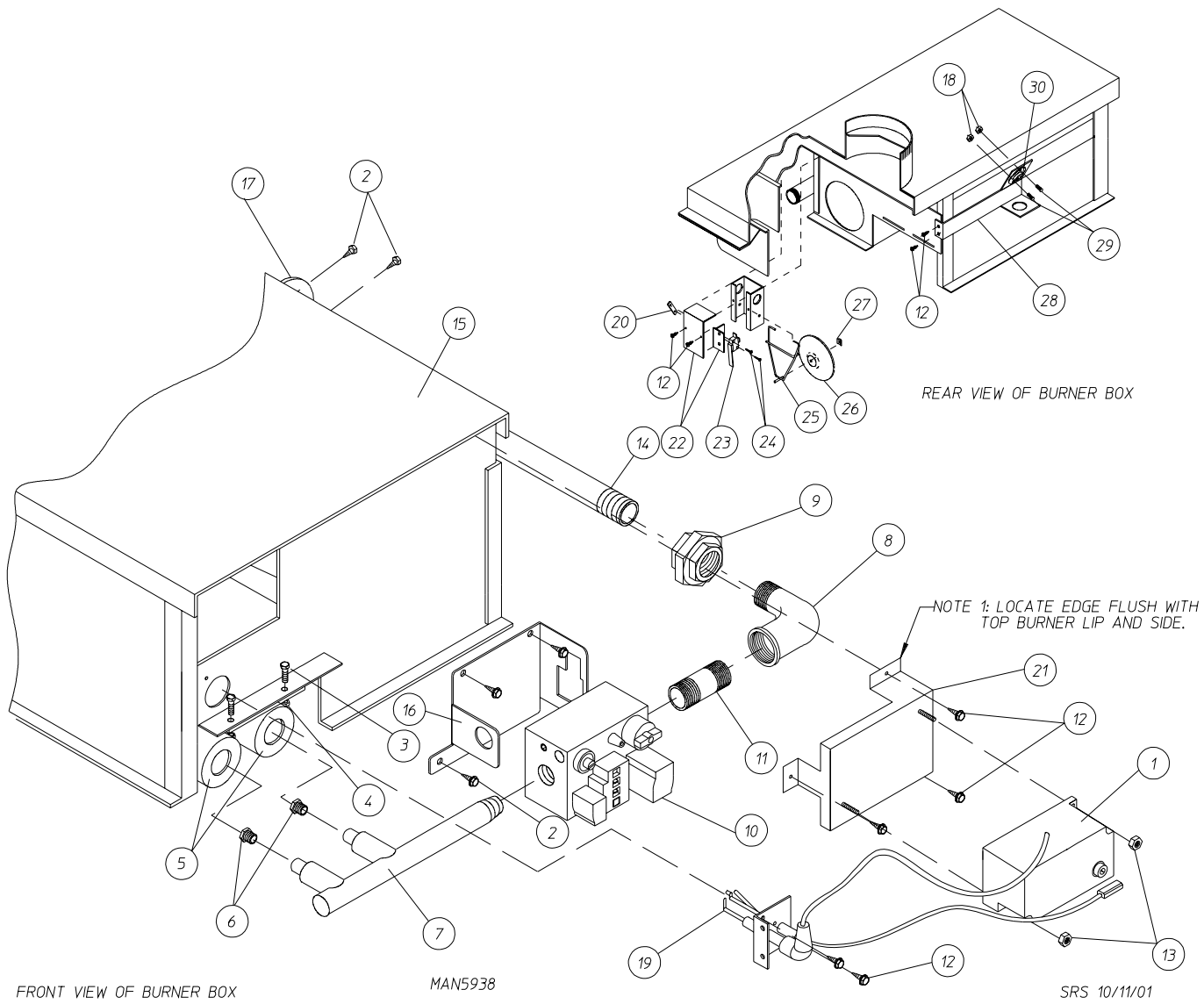

Direct Spark Ignition Burner Assembly

<u>Illus. No.</u>	<u>Part No.</u>	<u>Qty.</u>	<u>Description</u>
1	883849	1	Direct Spark Ignition Module Kit (for models with blue DSI module [Johnson])
	887133	1	Direct Spark Ignition Module (Current Probe) (for models with gray DSI module [Fenwal])
2	150309	5	#10-16 x 1/2" Hex Head TEK Crimptite Screw
3	150108	2	#8-32 x 1/2" Pan Head Machine Screw
4	151001	2	#8-32 Pal Nut
5	141104	2	Small Tube Burner
6	140855	2	#33 Burner Orifice (for natural gas)
	140801	2	#51 Burner Orifice (for propane gas)
7	141230	1	1/2" Manifold (2 port)
8	142506	1	1/2" x 1/2" Street Elbow
9	142600	1	1/2" Black Union
10	128927	1	1/2" 24 VAC (natural gas) Gas Valve
	880960	1	1/2" 24 VAC (propane gas) Gas Valve
11	142707	1	1/2" x 1-1/2" Long Black Nipple
12	150300	9	#10-16 x 1/2" Hex Washer TEK Screw
13	152013	2	#6-32 Hex Nut
14	142809	1	1/2" x 29-1/8" Black Nipple
15	850862	1	Burner Box and Bonnet Only
	883174	1	Burner Box Assembly (natural gas) (includes illus. nos. 1 through 5 and 7 through 30)
	809732	1	Burner Box Assembly (propane gas) (includes illus. nos. 1 through 5 and 7 through 30)
16	318714	1	Bracket for Horizontal Facing Gas Valve
17	318700	1	Pipe Bracket
18	151000	2	#6-32 Pal Nut
19	884265	1	Direct Spark Ignition Ignitor / Flame-Probe without High Voltage Wire
	884278	1	High Voltage Wire (Gray) with 1/4" Terminal and Boot
20	154004	1	Twin Speed Nut
21	810030	1	Direct Spark Ignition Module Mounting Bracket
22	802799	1	Sail Switch Box Top and Switch Bracket
23	122200	1	Sail Switch
24	150303	2	#4 x 3/4" Pan Head Machine Screw
25	105500	1	Sail Switch Actuator Rod
26	319202	1	Sail Switch Damper (flat)
27	154002	1	1/8" Push-On Fastener
28	319704	1	Hi-Limit Mounting Bracket
29	150001	2	#6-32 x 1/2" Phillips Round Head Machine Screw
30	130403	1	330° Hi-Limit Thermostat

Microprocessor Single-Phase (1 ϕ) Rear Electric Panel Assembly

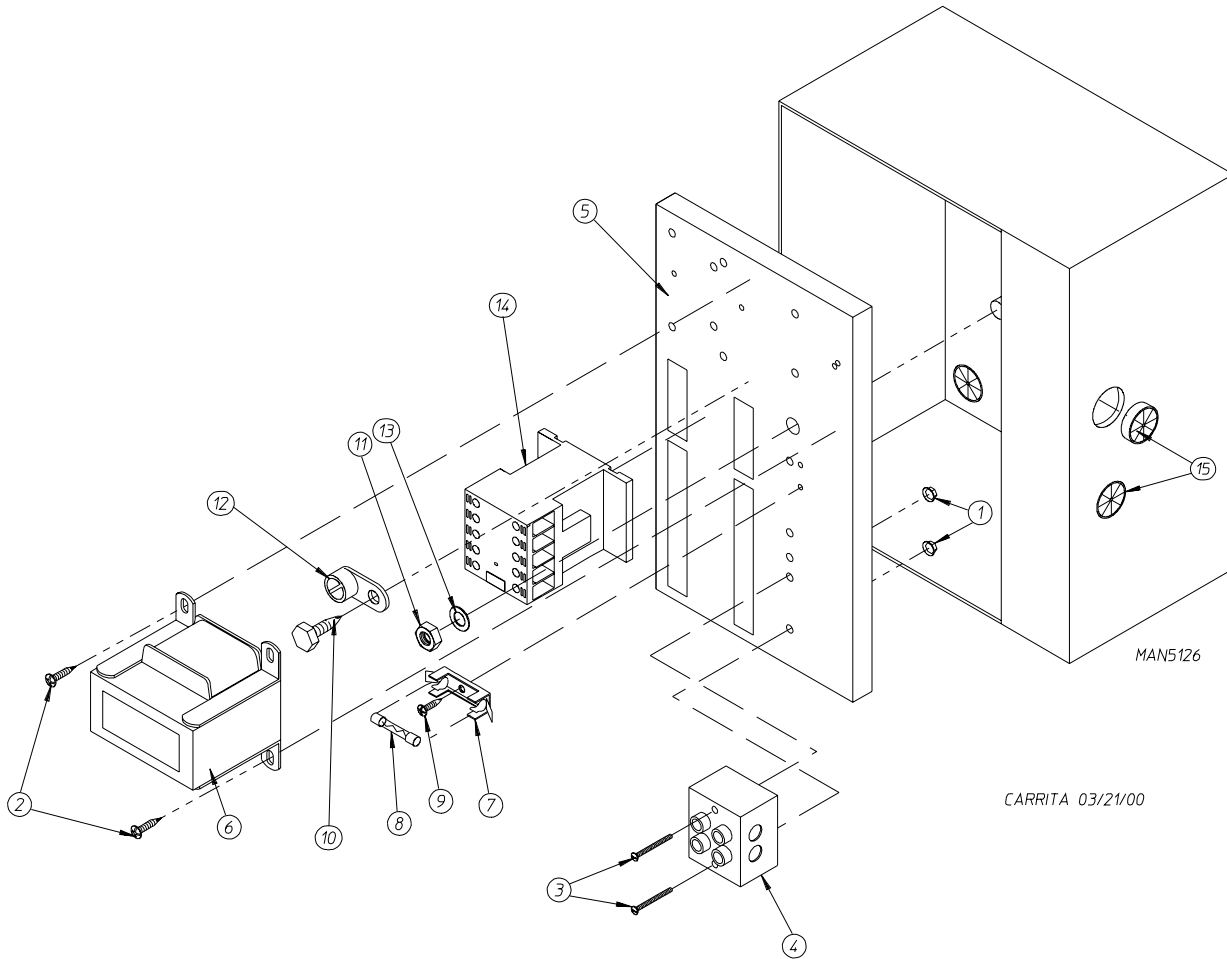

CARRITA 03/21/00

Illus. No.	Part No.	Qty.	Description
1	151000	2	#6-32 Pal Nut
2	150300	2	#10-16 x 1/2" Hex Washer TEK Screw
3	150008	2	#6-32 x 1-1/4" Phillips Pan Head Machine Screw
4	120716	1	2-Position Terminal Block
5	322812	1	Rear Electric Mounting Plate Only
	822796	1	Rear Electric Panel Assembly Complete – 115 Volt (includes illus. nos. 1 through 14)
	822798	1	Rear Electric Panel Assembly Complete – 208-240 Volt (includes illus. nos. 1 through 14)
6	822794	1	Transformer Assembly – 115 Volt
	822799	1	Transformer Assembly – 208-240 Volt
7	136008	*	Fuse Holder
8	136057	2	1/2-Amp (Slo-Blo) Fuse (for 208-240 volt)
	136049	1	3/4-Amp (Slo-Blo) Fuse (for 115 volt)
9	150301	4	#8-18 x 7/16" Phillips Pan Head TEK Screw
10	150297	1	#10 x 1/2" Green Hex Washer TEK Screw
11	152004	1	5/16-18 Hex Nut
12	121010	1	L-70 Ground Lug
13	153002	1	5/16" Lock Washer
14	132495	1	3-Pole Contactor
15	121300	3	Open / Closed Bushing

* Quantity is 1 for 115 Volt and 2 for 208-240 Volt.

Microprocessor 3-Phase (3Ø) Rear Electric Panel Assembly

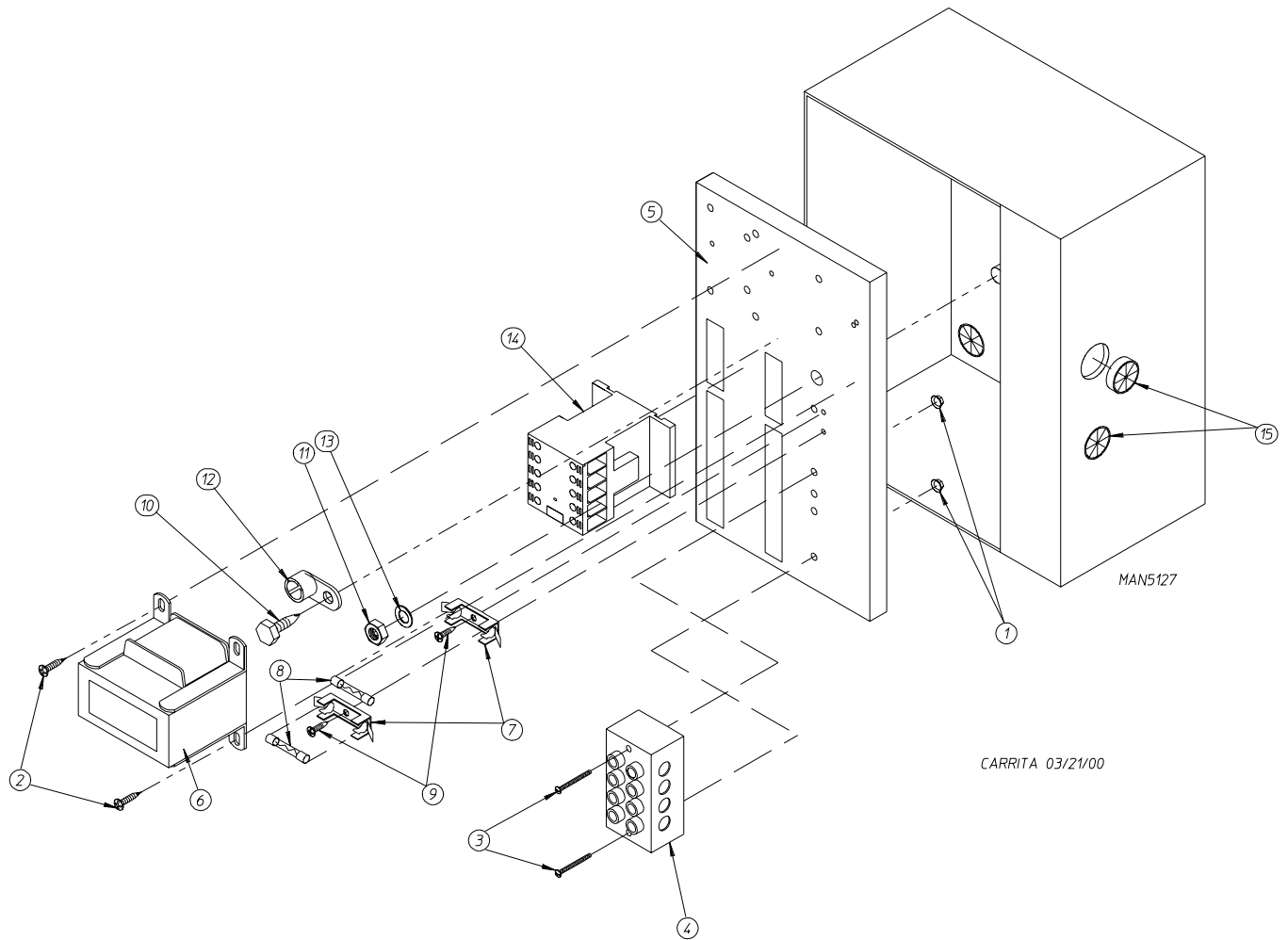

Illus. No.	Part No.	Qty.	Description
1	151000	2	#6-32 Pal Nut
2	150300	2	#10-16 x 1/2" Hex Washer TEK Screw
3	150008	2	#6-32 x 1-1/4" Phillips Pan Head Machine Screw
4	120701	1	4-Position Terminal Block
5	322812	1	Rear Electric Mounting Plate Only
	830154	1	Rear Electric Panel Assembly Complete – 208-240 Volt (includes illus. nos. 1 through 14)
6	822799	1	Transformer Assembly – 208-240 Volt
7	136008	2	Fuse Holder
8	136057	2	1/2-Amp (Slo-Blo) Fuse
9	150301	4	#8-18 x 7/16" Phillips Pan Head TEK Screw
10	150297	1	#10 x 1/2" Green Hex Washer TEK Screw
11	152004	1	5/16-18 Hex Nut
12	121010	1	L-70 Ground Lug
13	153002	1	5/16" Lock Washer
14	132495	1	3-Pole Contactor
15	121300	3	Open / Closed Bushing

Mechanical Timer Single-Phase (1 ϕ) Rear Electric Panel Assembly

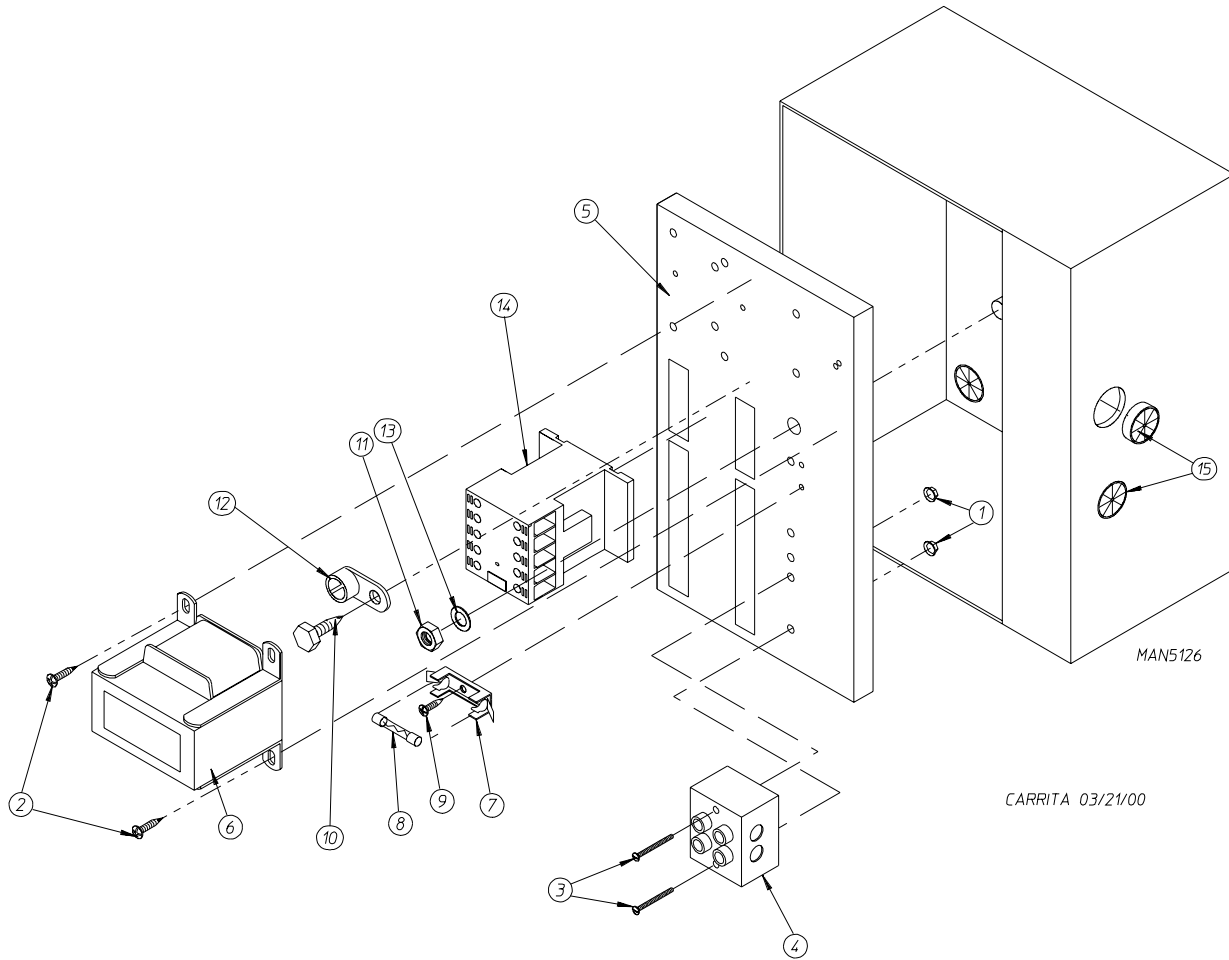

Illus. No.	Part No.	Qty.	Description
1	151000	2	#6-32 Pal Nut
2	150300	2	#10-16 x 1/2" Hex Washer TEK Screw
3	150008	2	#6-32 x 1-1/4" Phillips Pan Head Machine Screw
4	120716	1	2-Position Terminal Block
5	322817	1	Rear Electric Mounting Plate Only
	882662	1	Rear Electric Panel Assembly Complete – 120 Volt (includes illus. nos. 1 through 14)
	882663	1	Rear Electric Panel Assembly Complete – 208-240 Volt (includes illus. nos. 1 through 14)
6	882652	1	Transformer Assembly – 120 Volt
	882653	1	Transformer Assembly – 208-240 Volt
7	136008	1 or 2	Fuse Holder
8	136049	1	3/4-Amp (Slo-Blo) Fuse – 120 Volt
	136057	2	1/2-Amp (Slo-Blo) Fuse – 208-240 Volt
9	150301	1 or 2	#8-18 x 7/16" Phillips Pan Head TEK Screw
10	150297	1	#10 x 1/2" Green Hex Washer TEK Screw
11	152004	1	5/16-18 Hex Nut
12	121010	1	L-70 Ground Lug
13	153002	1	5/16" Lock Washer
14	132459	1	3-Pole Contactor
15	121300	3	Open / Closed Bushing

Mechanical Timer 3-Phase (3Ø) Rear Electric Panel Assembly

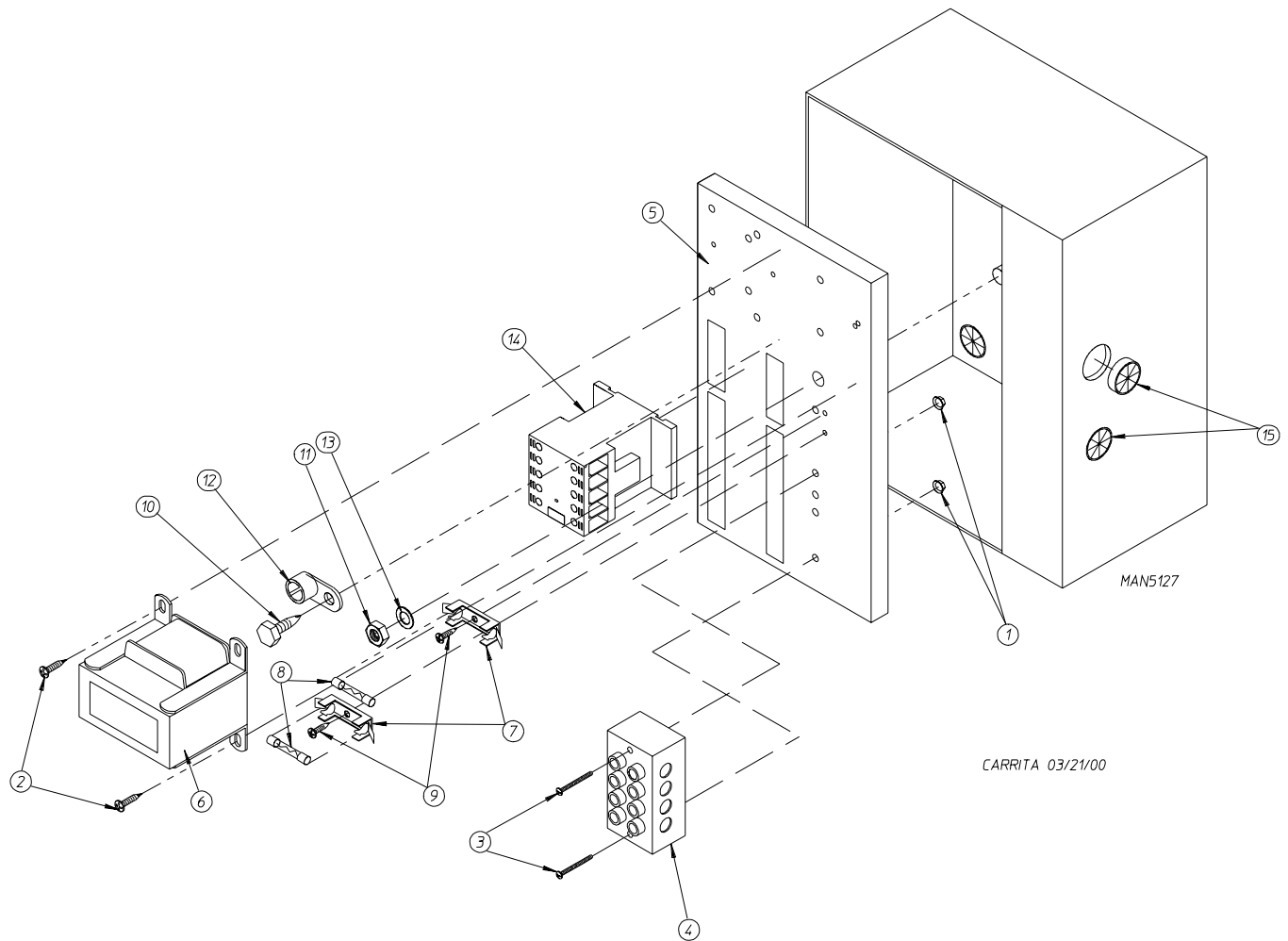

Illus. No.	Part No.	Qty.	Description
1	151000	2	#6-32 Pal Nut
2	150300	2	#10-16 x 1/2" Hex Washer TEK Screw
3	150008	2	#6-32 x 1-1/4" Phillips Pan Head Machine Screw
4	120701	1	4-Position Terminal Block
5	322817	1	Rear Electric Mounting Plate Only
	882664	1	Rear Electric Panel Assembly Complete – 208-240 Volt (includes illus. nos. 1 through 14)
6	882653	1	Transformer Assembly – 208-240 Volt
7	136008	2	Fuse Holder
8	136057	2	1/2-Amp (Slo-Blo) Fuse
9	150301	2	#8-18 x 7/16" Phillips Pan Head TEK Screw
10	150297	1	#10 x 1/2" Green Hex Washer TEK Screw
11	152004	1	5/16-18 Hex Nut
12	121010	1	L-70 Ground Lug
13	153002	1	5/16" Lock Washer
14	132459	1	3-Pole Contactor
15	121300	3	Open / Closed Bushing

Fire Suppression System Assembly

For Models Mfd. as of November 8, 2011

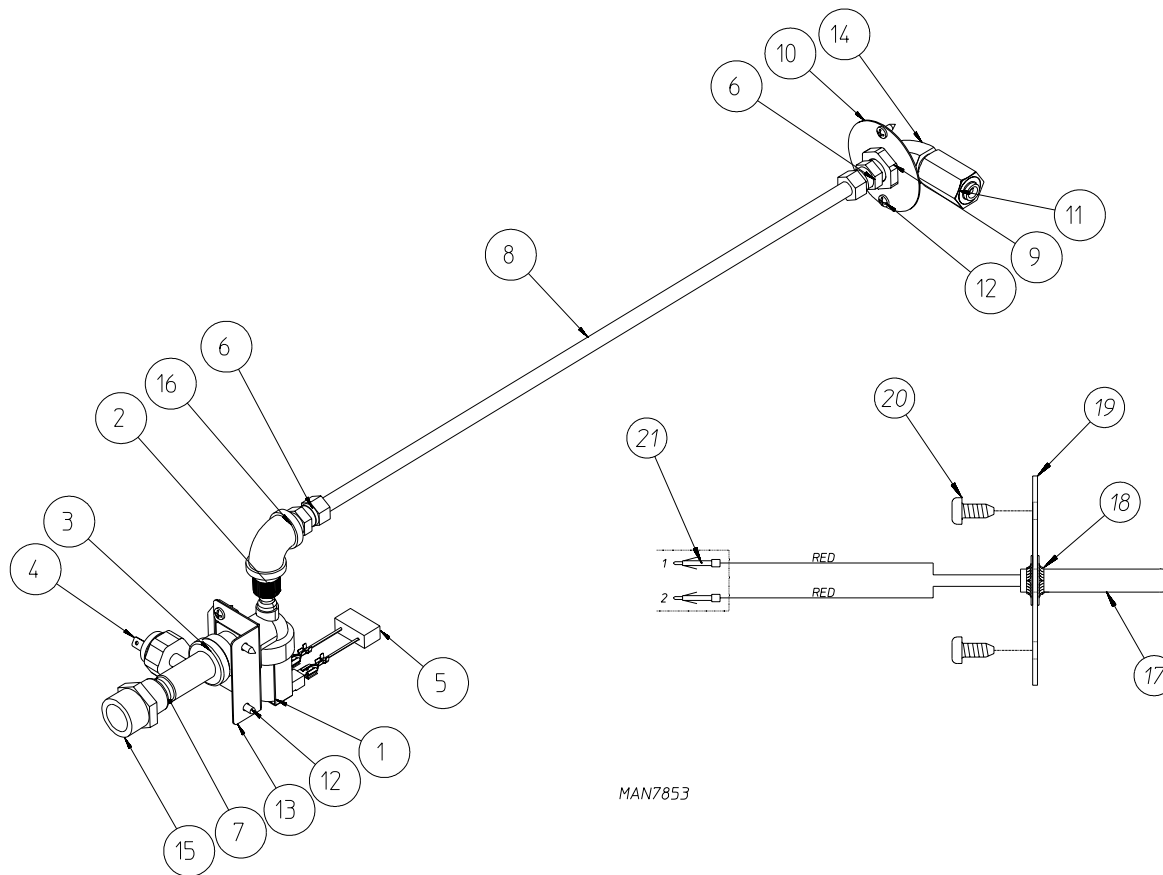

MAN7853

<u>Illus. No.</u>	<u>Part No.</u>	<u>Qty.</u>	<u>Description</u>
1	165119	1	Fire Suppression System H ₂ O Valve 24VAC
2	143183	1	7/16-20 x 3/8 NPD Brass Adaptor
3	143182	1	3/4GHT x 1/8 x 3/8 NPT Brass Tee
4	136987	1	Water Pressure Switch
5	824081	1	RC Network Assembly
6	143208	2	3/8 Comp x 3/8 MPT Brass Connect
7	143241	1	3/8 x Close Brass Nipple
8	143099	1	3/8" OD x .035 Wall Copper Tubing
9	143303	1	3/8 NPT Brass Lock Nut
10	311588	1	Fire Suppression System Sprinkler Head Mounting Plate
11	143581	1	Fire Suppression System 3GPM 3/8 NPT Spray Nozzle
12	150301	6	#8-18 x 7/16 PHL-PH-TEX PLTD
13	313962	1	Main Line F.S.S. 90° Valve Bracket
14	143155	1	3/8 Brass Street Elbow
15	143025	1	3/8 NPT x 3/4 NH Nylon Adaptor
16	143310	1	3/8 Brass 90° Elbow
—	817574	1	Fire Suppression System Assembly Complete (includes illus. nos. 1 through 16)
17	822752	1	Fire Suppression System Temperature Probe Assembly (includes illus. nos. 17 through 19 and 21)
18	159007	2	Push-On Fastener
19	390390	1	Sensor Bracket Only
20	150301	2	#8-18 x 7/16" Phillips Pan Head TEK Screw
21	122647	1	Connector Only (does not include terminals)

Fire Suppression System Assemblies

For Models Mfd. prior to November 8, 2011

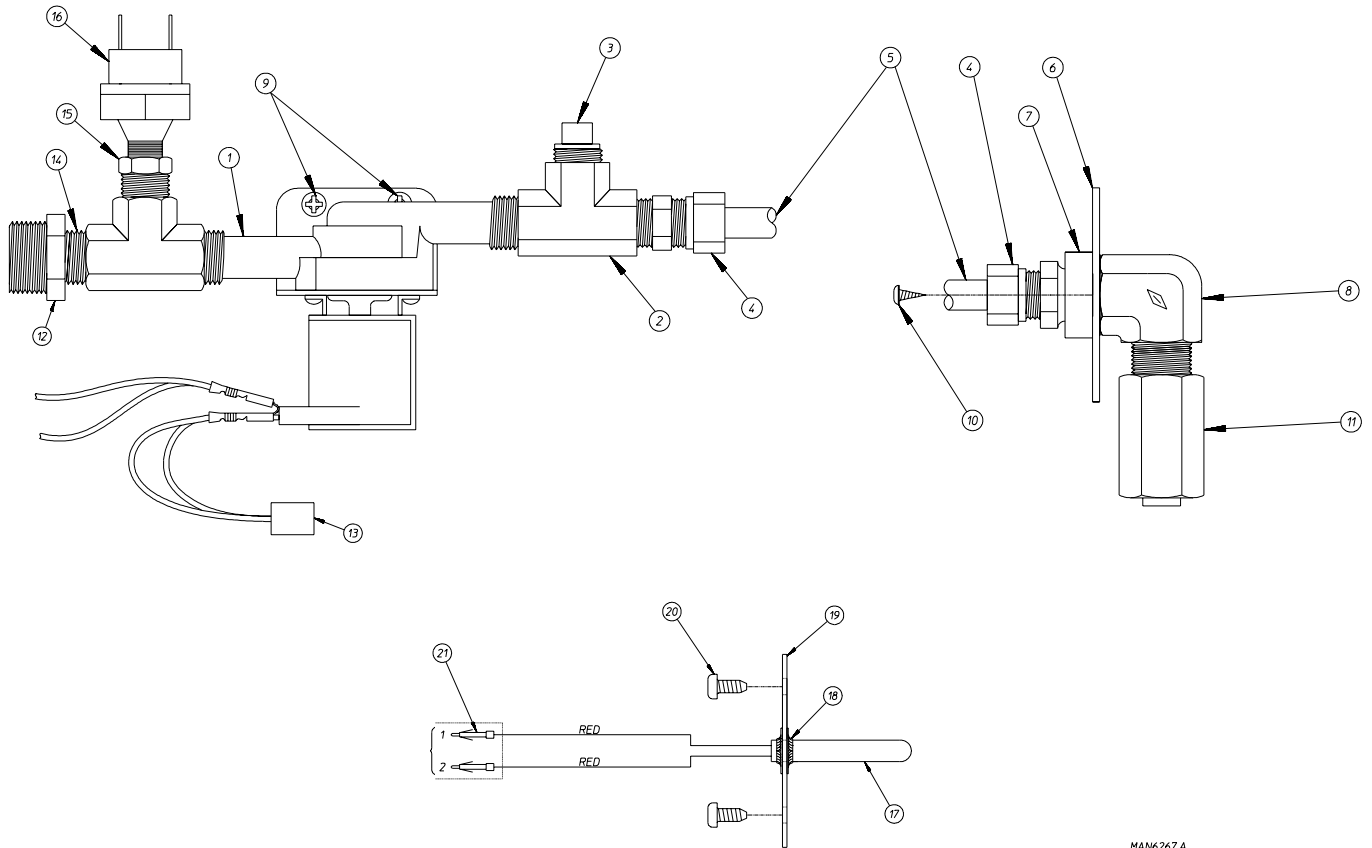

MAN6267.A

<u>Illus. No.</u>	<u>Part No.</u>	<u>Qty.</u>	<u>Description</u>
1	165114	1	Fire Suppression System Solenoid Valve 24V 50/60 Hz
2	143220	1	3/8" F.P.T. Brass Tee
3	143251	1	3/8" M.P.T. Brass Plug
4	143208	2	3/8" Comp x 3/8" M.P.T. Brass Connector
5	143099	6'	3/8" OD x 0.035 Wall Copper Tubing (sold by the foot)
6	311588	1	Sprinkler Head Mounting Plate
7	143303	1	3/8" N.P.T. Brass Locknut
8	143155	1	3/8" Brass Elbow 90°
9	150430	2	#10 x 1/2" Self-Drilling Screw
10	150301	2	#8-18 x 7/16" TEK Screw
11	143581	1	3 GPM 3/8" F.P.T. Spray Nozzle
12	143025	1	3/8 x 3/4 NH 60 Hz
	143177		3/4 M.P.T. x 3/8 Adapt 50 Hz
13	824081	1	R.C. Network Assembly
14	143241	1	3/8" x Close Brass Nipple
15	143315	1	3/8" M.N.P.T. x 1/8" F.N.P.T. Brass Bushing
16	136987	1	Water Jet Pressure Switch (for models mfd. as of December 1, 2003)
17	822752	1	Fire Suppression System Temperature Probe Assembly (includes illus. nos. 17 through 19 and 21)
18	154007	2	Push-On Fastener
19	390390	1	Sensor Bracket Only
20	150301	2	#8-18 x 7/16" Phillips Pan Head TEK Screw
21	122647	1	Connector Only (does not include terminals)

Outer Top / Back Guard Assemblies

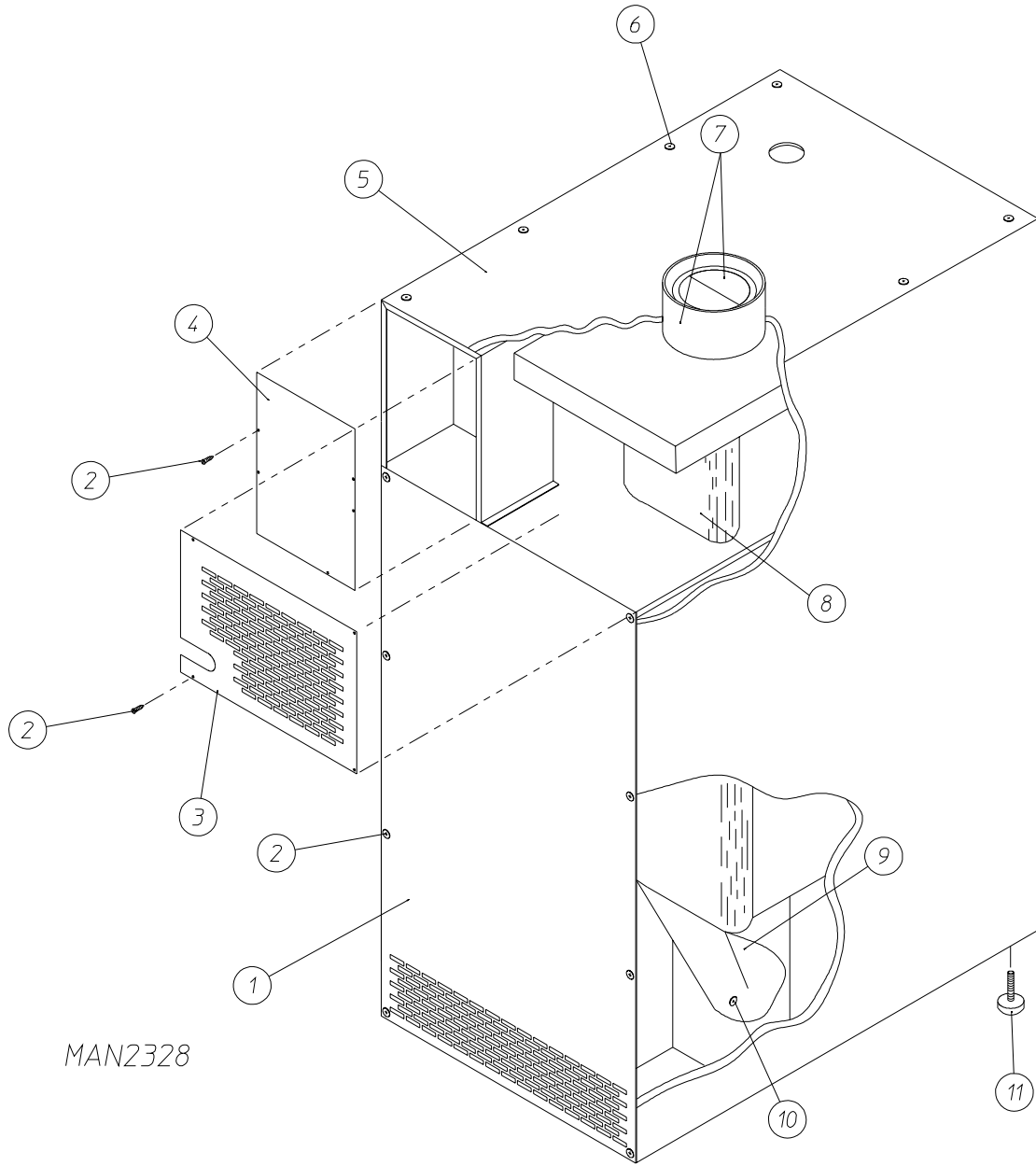

MAN2328

Illus. No.	Part No.	Qty.	Description
1	330608	1	"Plain" Bottom Back Guard
2	150301	16	#8-18 x 7/16" Phillips Pan Head TEK Screw
3	330614	1	Top Back Guard Only
4	322809	1	Back Electrical Box Cover
5	330619	1	Outer Top Guard Only
6	150301	8	#8-18 x 7/16" Phillips Pan Head TEK Screw
7	880502	1	Heat Reclaimer (6") Damper Assembly
8	143517	1	42" Long x 7" Oval Duct
9	143515	1	6" Round x 7" Oval - 90° Boot
10	150300	2	#10-16 x 1/2" Hex Washer TEK Screw
11	103500	4	Leveling Leg
—	117505	4	Aluminum Duct Tape (sold by the foot) ... Not Illustrated

<u>Part No.</u>	<u>Description</u>
114006	“WARNING – Fire Hazards” Label
112280	“Clean Lint Screen” Label
114001	“CAUTION – Exhaust / Lint Screen” Label
114521	“Phase 7 Non-Coin Program Location Summary” Label
114548	“Phase 7 Coin Program Location Summary” Label
120100	3/8” Straight (BX) Connector
120300	3/8” x 45° (BX) Connector
120400	3/8” Red Jacket (BX) Insulator
120500	3/8” Jiffy Clip (BX) Retainer Clip
120600	3/8” Greenfield (BX)
120707	(2-Position) Terminal Strip
120708	(3-Position) Terminal Strip
120800	1/4” In-Line Connector
120802	Red Butt Connector
120902	#74B Wire Nut
120903	Crimp-On Wire Nut
121014	1/4” Insulated (female) Terminal
121026	Tab Receptacle Combination
121499	5-1/2” Harness Tie
121500	8” Harness Tie
122804	Manometer (hydro gauge) for Measuring Gas Pressure
404500	Almond Brush-In-Cap Bottle Touch-Up Paint
404502	White Brush-In-Cap Bottle Touch-Up Paint
404513	Wrinkle Blue Brush-In-Cap Bottle Touch-Up Paint

