



AD-360X2

Parts Manual

Phase 7

American Dryer Corporation
88 Currant Road
Fall River MA 02720-4781 USA
Telephone: +1 (508) 678-9000 / Fax: +1 (508) 678-9447
e-mail: techsupport@amdry.com

www.adclaundry.com

Retain This Manual In A Safe Place For Future Reference

American Dryer Corporation products embody advanced concepts in engineering, design, and safety. If this product is properly maintained, it will provide many years of safe, efficient, and trouble free operation.

ONLY qualified technicians should service this equipment.

OBSERVE ALL SAFETY PRECAUTIONS displayed on the equipment or specified in the installation manual included with the dryer.

The following “**FOR YOUR SAFETY**” caution must be posted near the dryer in a prominent location.

FOR YOUR SAFETY

Do not store or use gasoline or other flammable vapors and liquids in the vicinity of this or any other appliance.

POUR VOTRE SÉCURITÉ

Ne pas entreposer ni utiliser d'essence ni d'autres vapeurs ou liquides inflammables à proximité de cet appareil ou de tout autre appareil.

We have tried to make this manual as complete as possible and hope you will find it useful. ADC reserves the right to make changes from time to time, without notice or obligation, in prices, specifications, colors, and material, and to change or discontinue models.

Important

For your convenience, log the following information:

DATE OF PURCHASE _____ MODEL NO. **AD-360X2**

RESELLER'S NAME _____

Serial Number(s) _____

Replacement parts can be obtained from your reseller or the ADC factory. When ordering replacement parts from the factory, you can FAX your order to ADC at (508) 678-9447 or telephone your order directly to the ADC Parts Department at (508) 678-9000. Please specify the dryer model number and serial number in addition to the description and part number, so that your order is processed accurately and promptly.

The illustrations on the following pages may not depict your particular dryer exactly. The illustrations are a composite of the various dryer models. Be sure to check the descriptions of the parts thoroughly before ordering.

“IMPORTANT NOTE TO PURCHASER”

Information must be obtained from your local gas supplier on the instructions to be followed if the user smells gas. These instructions must be posted in a prominent location near the dryer.

For Detailed Information
See The Table Of Contents On Next Page

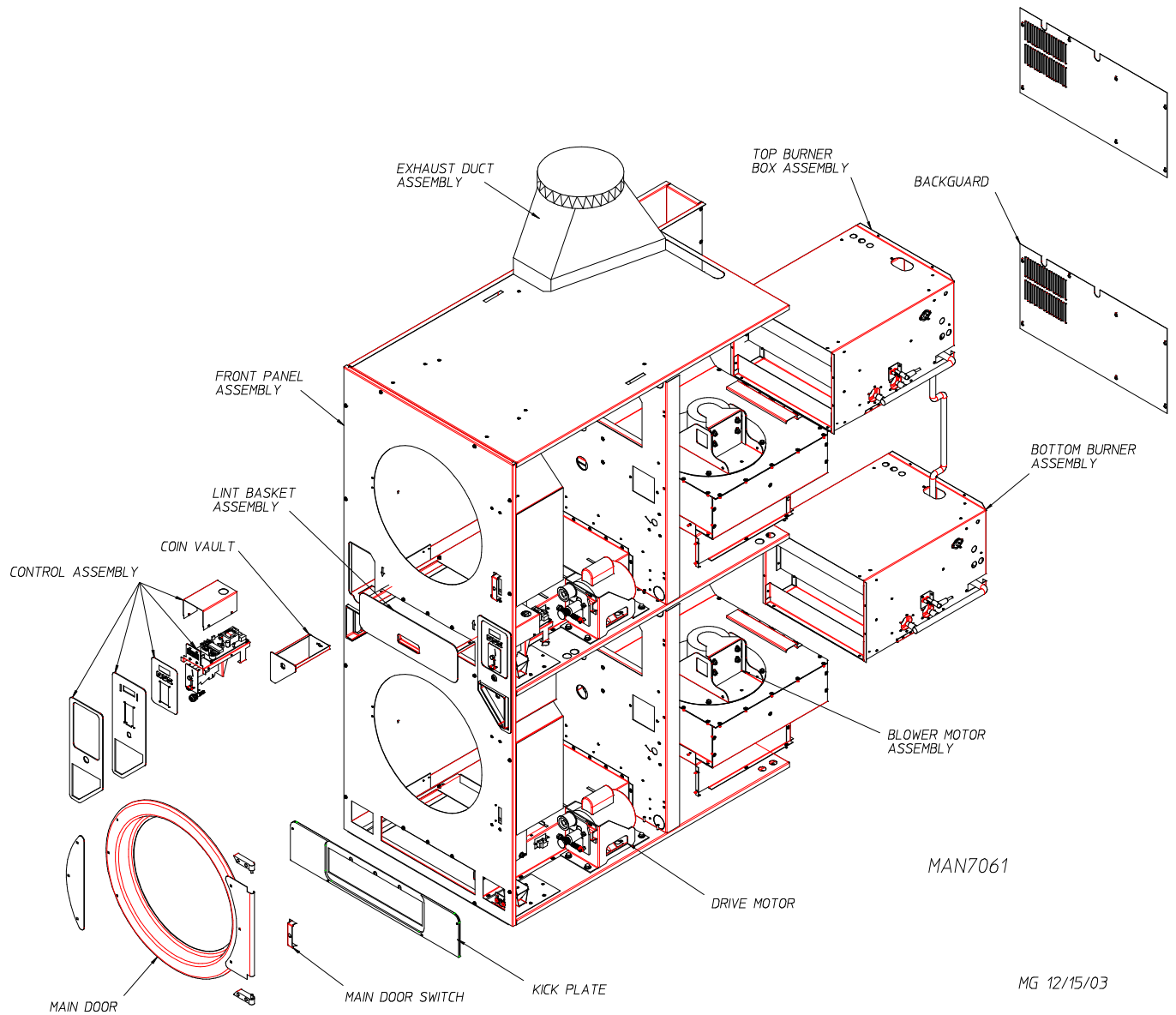
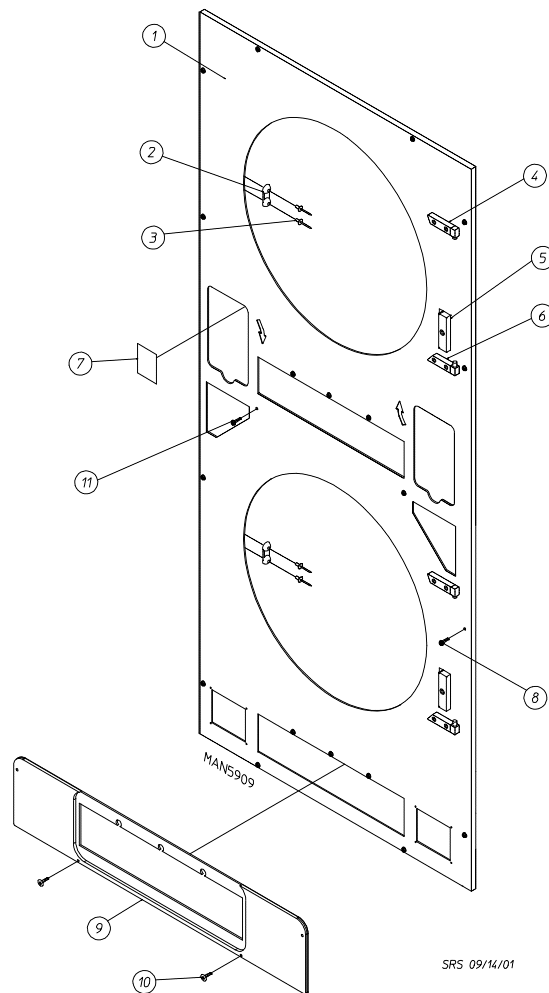

Table of Contents

Coin Front Panel Assembly	5
Non-Coin Front Panel Assembly	6
Right Coin Computer Panel Assembly	7
Left Coin Computer Panel Assembly	8
Non-Coin Computer Panel Assembly	9
Coin Chute Assembly	10
Easy Debit Card Coin Chute Assembly	11
Coin Box / Vault Assembly (Left and Right)	12
Main Door "Steel" Assembly	13
Main Door Switch Assembly	14
Tumbler / Support Assemblies	15
Top Locking Lint Basket Assembly	16
Bottom Locking Lint Basket Assembly	17
Top Lint Basket Assembly	18
Bottom Lint Basket Assembly	19
Separator Assembly	20
Rotational Sensor / Sail Switch and Teflon® Backup Washer Plate	21
Lint Coop and Adjustment Wheel Bracket Assembly	22
Left Rear Wheel Bracket (3-Bolt)	23
Right Rear Wheel Bracket (3-Bolt)	24
Microprocessor Temperature Sensor Bracket Assembly	25
Top Burner Box Assembly	26
Bottom Burner Box Assembly	27
Blower Motor Assembly	28
Rear Electrical Panel (Top and Bottom)	29
Drive Motor / Motor Mount Assemblies	30
Exhaust Duct Assembly	31
Rear Back Guard Assembly	32
Wrapper Gasket	33



SRS 09/14/01

<u>Illus. No.</u>	<u>Part No.</u>	<u>Qty.</u>	<u>Description</u>
1	884117	1	White Right-Hand Coin Front Panel Assembly (includes illus. nos. 1 through 3 and 7)
	884118	1	Bisque Right-Hand Coin Front Panel Assembly (includes illus. nos. 1 through 3 and 7)
	884119	1	Stainless Steel Right-Hand Coin Front Panel Assembly (includes illus. nos. 1 through 3 and 7)
2	881987	2	Friction Door Latch Kit (includes illus. nos. 2 and 3)
3	154215	4	5/32" x 1/4" Rivet
4	_____	1	Top Hinge Block Assembly (refer to Main Door "Steel" Assembly on page 13)
5	_____	1	Main Door Switch (refer to Main Door Switch Assembly on page 14)
6	_____	1	Bottom Hinge Block Assembly (refer to Main Door "Steel" Assembly on page 13)
7	354267	2	Arrow Backup Plate
8	150517	10	#10-16 x 1-1/2" Hex Head TEK Screw
9	882798	1	Black Kick Plate
10	150311	2	#10-16 x 3/4" Hex Head TEK Crimptite Screw
11	150309	8	#10-16 x 1/2" Hex Head TEK Crimptite Screw

Non-Coin Front Panel Assembly

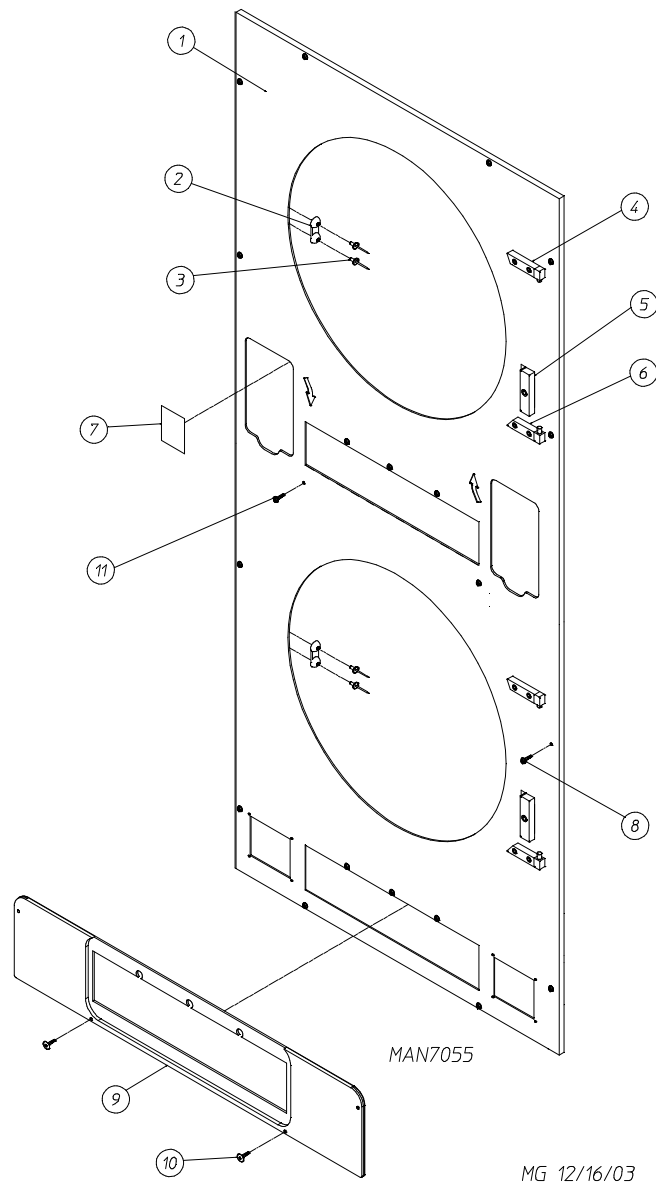

<u>Illus. No.</u>	<u>Part No.</u>	<u>Qty.</u>	<u>Description</u>
1	884120	1	White Right-Hand Front Panel Assembly (includes illus. nos. 1 through 3 and 7)
	884121	1	Bisque Right-Hand Front Panel Assembly (includes illus. nos. 1 through 3 and 7)
2	881987	2	Friction Door Latch Kit (includes illus. nos. 2 and 3)
3	154215	4	5/32" x 1/4" Rivet
4	—	1	Top Hinge Block Assembly (refer to Main Door "Steel" Assembly on page 13)
5	—	1	Main Door Switch (refer to Main Door Switch Assembly on page 14)
6	—	1	Bottom Hinge Block Assembly (refer to Main Door "Steel" Assembly on page 13)
7	354267	2	Arrow Backup Plate
8	150517	10	#10-16 x 1-1/2" Hex Head TEK Screw
9	882798	1	Black Kick Plate
10	150311	2	#10-16 x 3/4" Hex Head TEK Crimpite Screw
11	150309	8	#10-16 x 1/2" Hex Head TEK Crimpite Screw

Right Coin Computer Panel Assembly

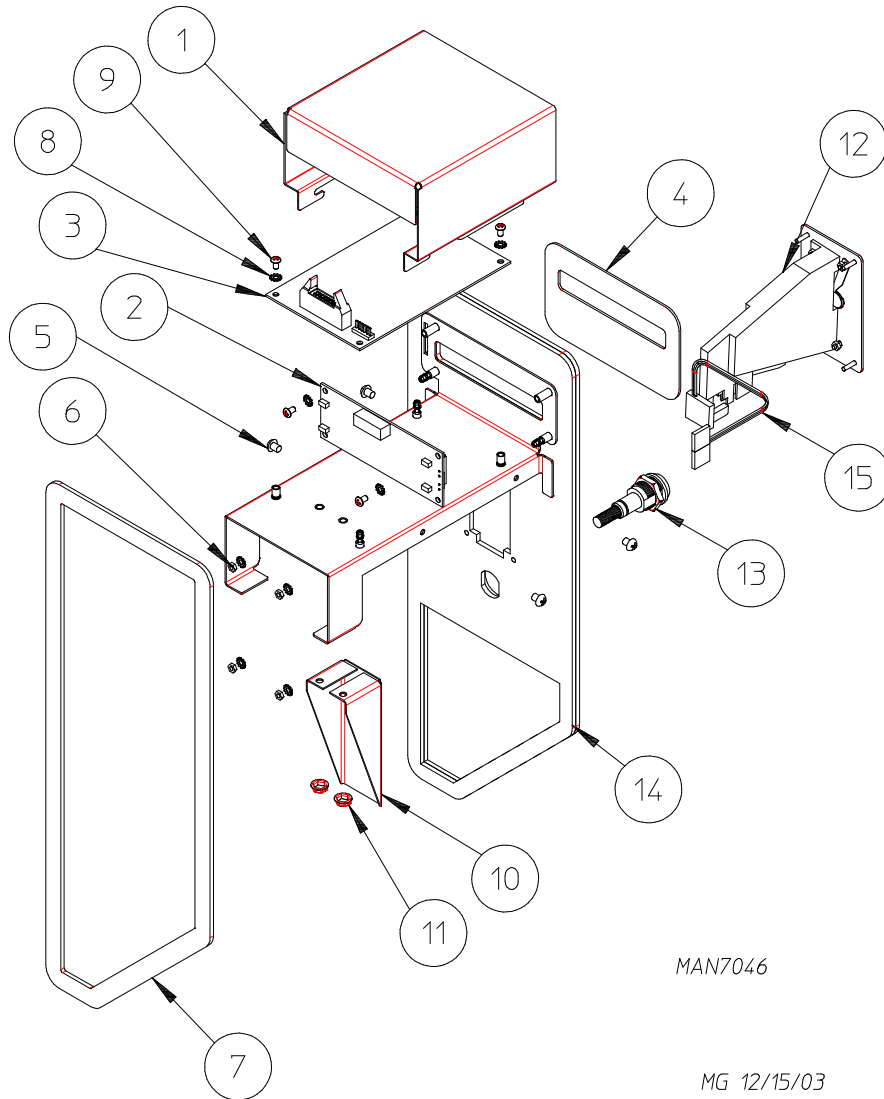

MAN7046

MG 12/15/03

<u>Illus. No.</u>	<u>Part No.</u>	<u>Qty.</u>	<u>Description</u>
1	354293	1	Computer Cover
2	137270	1	16" x 1" Large Character Display
3	887011	1	Phase 7 Coin Board (for models mfd. as of February 1, 2004)
	887007	1	Phase 7 Coin Board (for models mfd. prior to February 1, 2004)
4	112575	1	Phase 7 Keypad
5	150201	4	#10-32 x 1/4" Phillips Pan Head Tap Screw
6	152102	4	M3 Metric Hex Nut
7	117603	1	1/8" x 9/16" Noise Suppressor Tape
8	153010	8	#6 Internal / External Star Washer
9	150005	4	#6-32 x 1/4" Phillips Round Head Machine Screw
10	354192	1	Optic Switch Protector
11	151001	2	#8-32 Pal Nut
12	852317	1	Phase 7 25¢ Coin Acceptor Assembly
13	182621	1	Control Panel Lock Assembly
14	860078	1	Phase 7 Coin Control Panel (panel only)
15	883774	1	Hanke Phase 7 Optic Switch Assembly

Left Coin Computer Panel Assembly

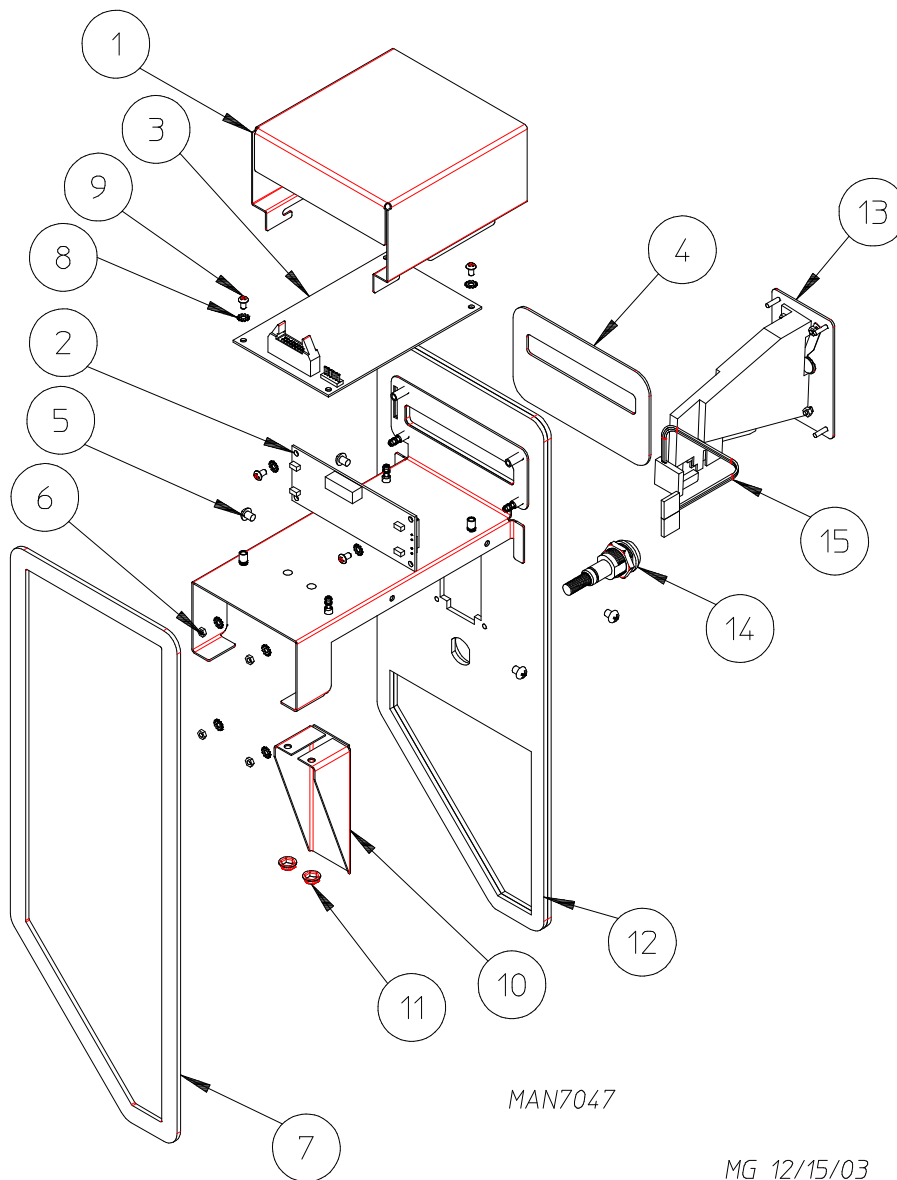

MAN7047

MG 12/15/03

<u>Illus. No.</u>	<u>Part No.</u>	<u>Qty.</u>	<u>Description</u>
1	354293	1	Computer Cover
2	137270	1	16" x 1" Large Character Display
3	887011	1	Phase 7 Coin Board (for models mfd. as of February 1, 2004)
	887007	1	Phase 7 Coin Board (for models mfd. prior to February 1, 2004)
4	112575	1	Phase 7 Keypad
5	150201	4	#10-32 x 1/4" Phillips Pan Head Tap Screw
6	152102	4	M3 Metric Hex Nut
7	117603	1	1/8" x 9/16" Noise Suppressor Tape
8	153010	1	#6 Internal / External Star Washer
9	150005	4	#6-32 x 1/4" Phillips Round Head Machine Screw
10	354192	1	Optic Switch Protector
11	151001	2	#8-32 Pal Nut
12	860080	1	Phase 7 Coin Control Panel (panel only)
13	852317	1	Phase 7 25¢ Coin Acceptor Assembly
14	182621	1	Control Panel Lock Assembly
15	883774	1	Hanke Phase 7 Optic Switch Assembly

Non-Coin Computer Panel Assembly

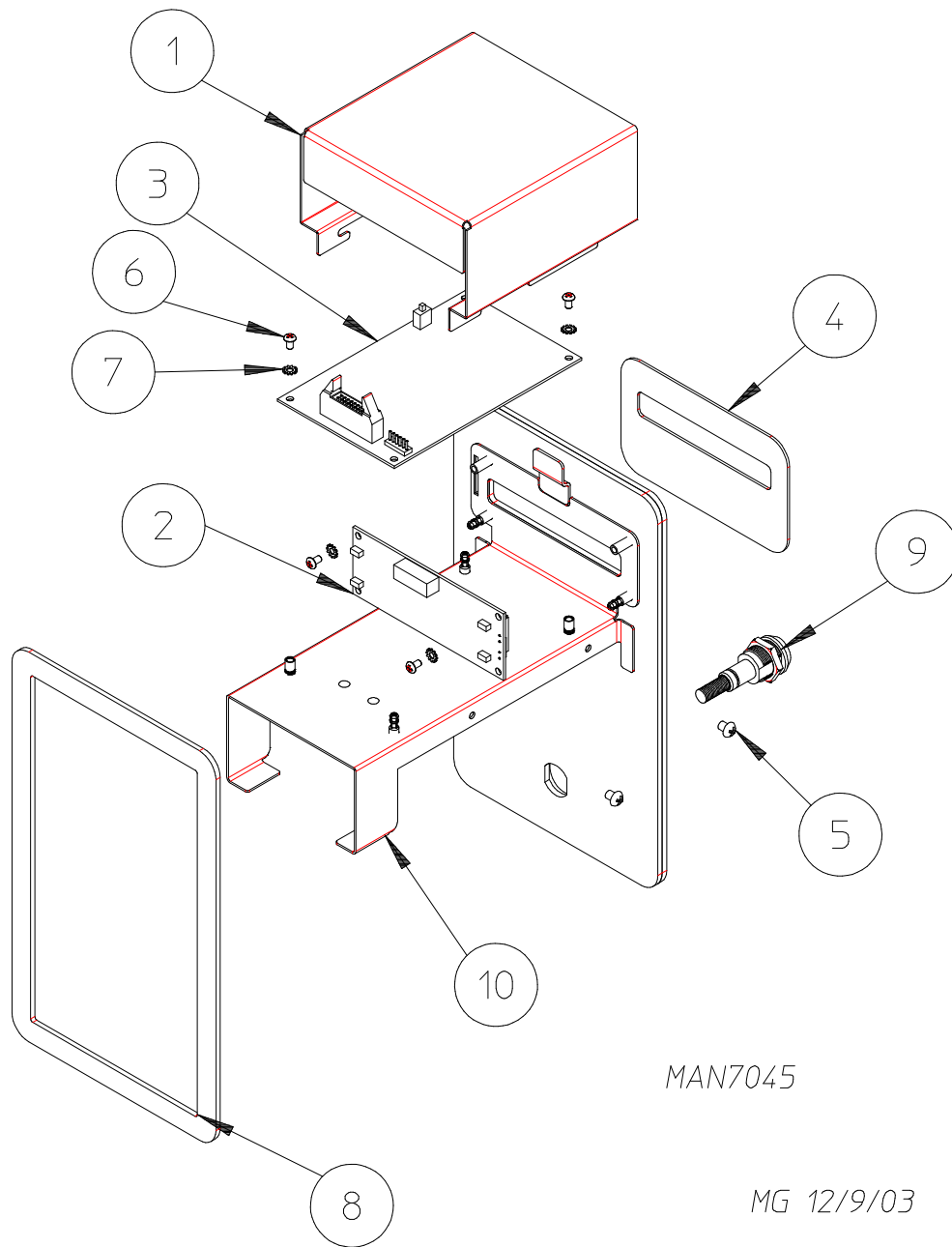

<u>Illus. No.</u>	<u>Part No.</u>	<u>Qty.</u>	<u>Description</u>
1	354293	1	Computer Cover
2	137270	2	16" x 1" Large Character Display
3	887011	1	Phase 7 Coin Board (for models mfd. as of February 1, 2004)
	887007	1	Phase 7 Coin Board (for models mfd. prior to February 1, 2004)
4	112575	1	Phase 7 Keypad
5	150201	4	#10-32 x 1/4" Phillips Pan Head Tap Screw
6	150005	4	#6-32 x 1/4" Phillips Round Head Machine Screw
7	153010	4	#6 Internal / External Star Washer
8	117603	1	1/8" x 9/16" Noise Suppressor Tape
9	182621	1	Control Panel Lock Assembly
10	860096	1	Phase 7.3 Non-Coin Computer Panel

Coin Chute Assembly

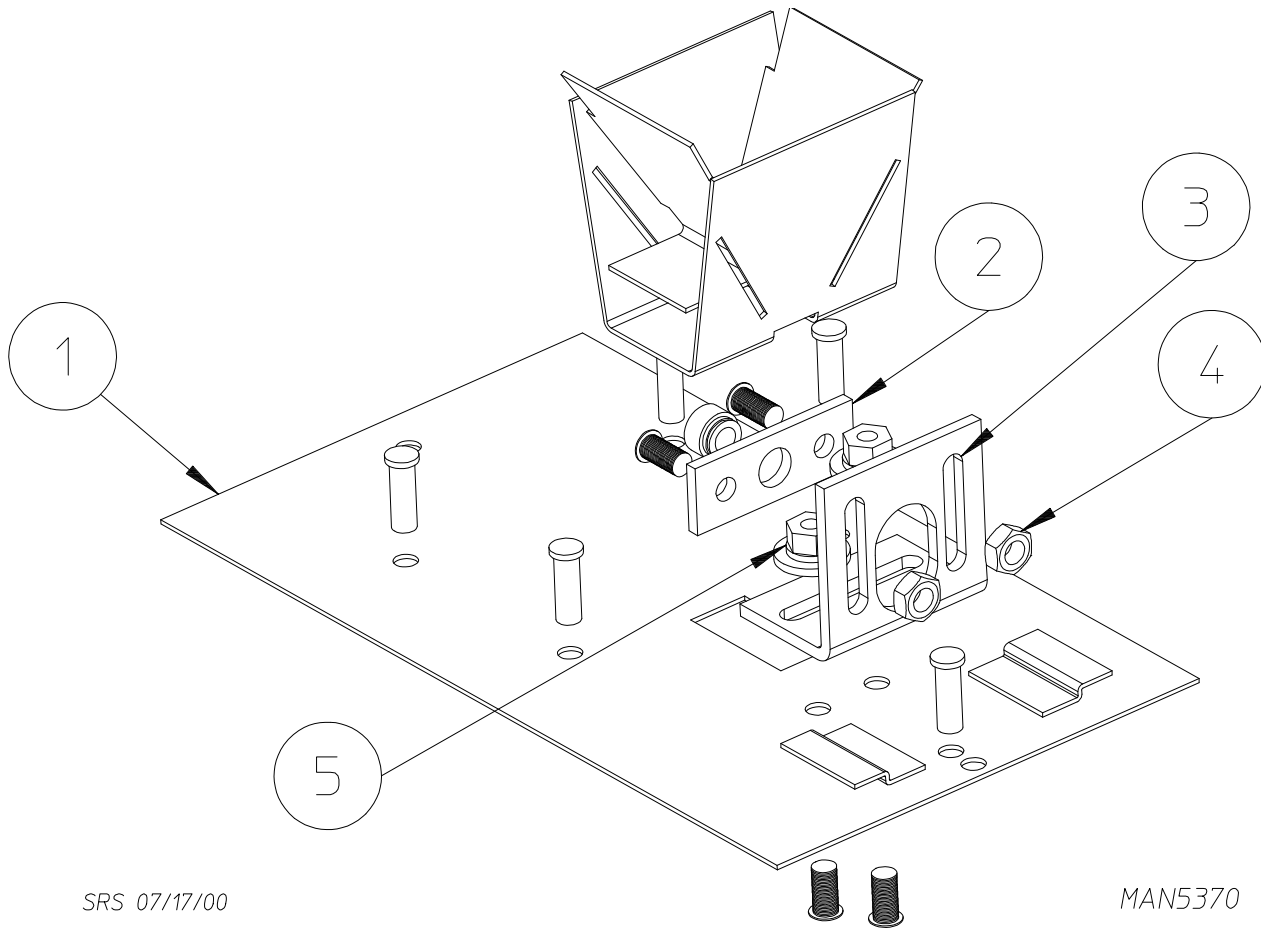

SRS 07/17/00

MAN5370

<u>Illus. No.</u>	<u>Part No.</u>	<u>Qty.</u>	<u>Description</u>
1	884113	1	Coin Chute Assembly Complete (includes illus. nos. 1 through 5)
2	882937	1	Control Panel Lock Plate
3	354046	1	Easy Card Lock Bracket
4	152002	2	1/4-20 Hex Nut
5	152014	2	1/4-20 Free Spin Wash Nut

Easy Debit Card Coin Chute Assembly

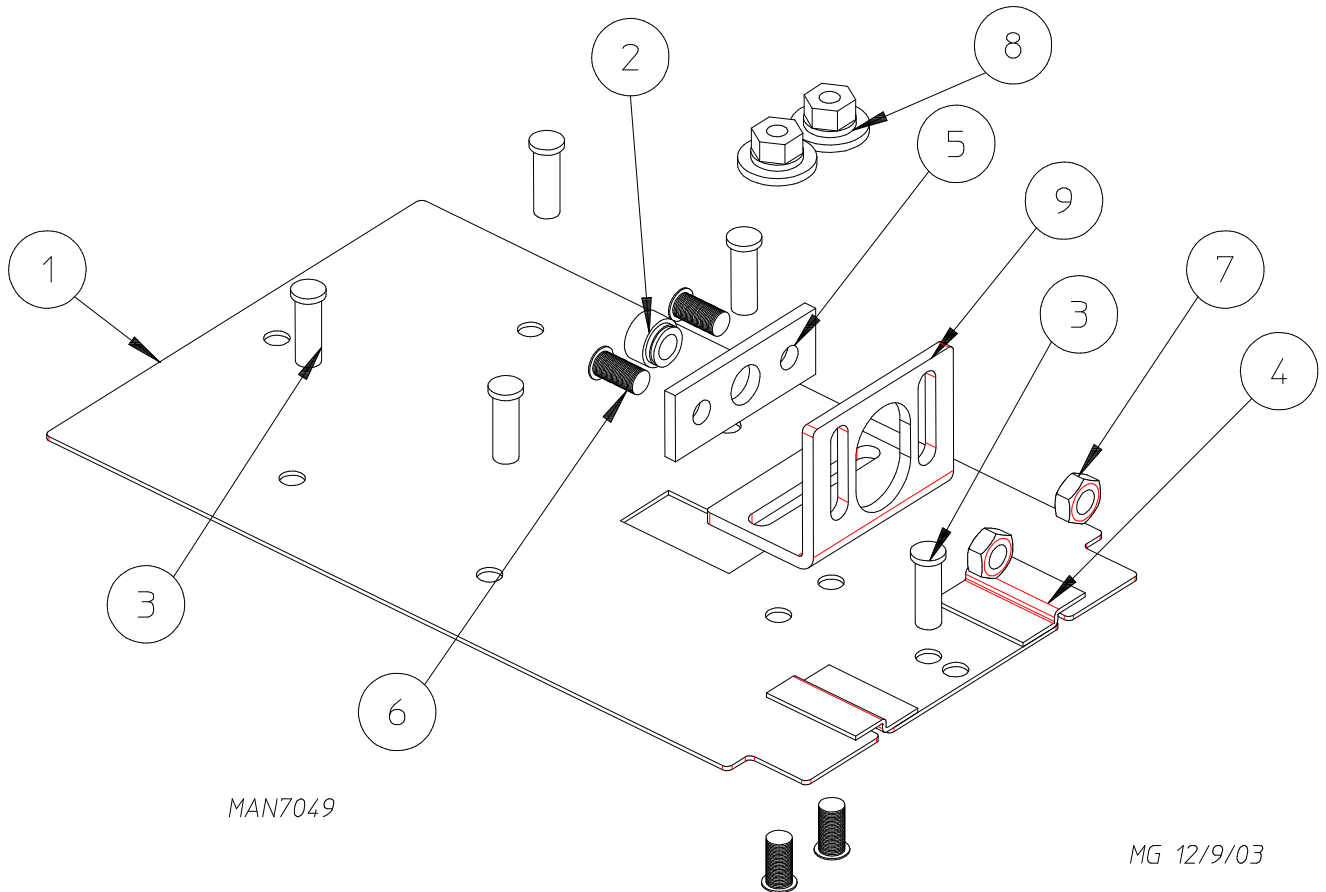

<u>Illus. No.</u>	<u>Part No.</u>	<u>Qty.</u>	<u>Description</u>
1	354114	1	Coin Chute Plate
2	153599	1	5/16-18 Clinch Nut
3	153557	5	1/4" x 3/4" Clinch Stud
4	354176	2	Control Panel Slide Clip
5	354181	1	Control Panel Lock Plate
6	153526	4	1/4" x 1/2" Clinch Stud
7	152002	2	1/4-20 Hex Nut
8	152014	2	1/4-20 Free Spin Wash Nut
9	354046	1	Easy Card Lock Bracket
	884124	1	Easy Debit Card Coin Chute Assembly

Coin Box / Vault Assembly (Left and Right)

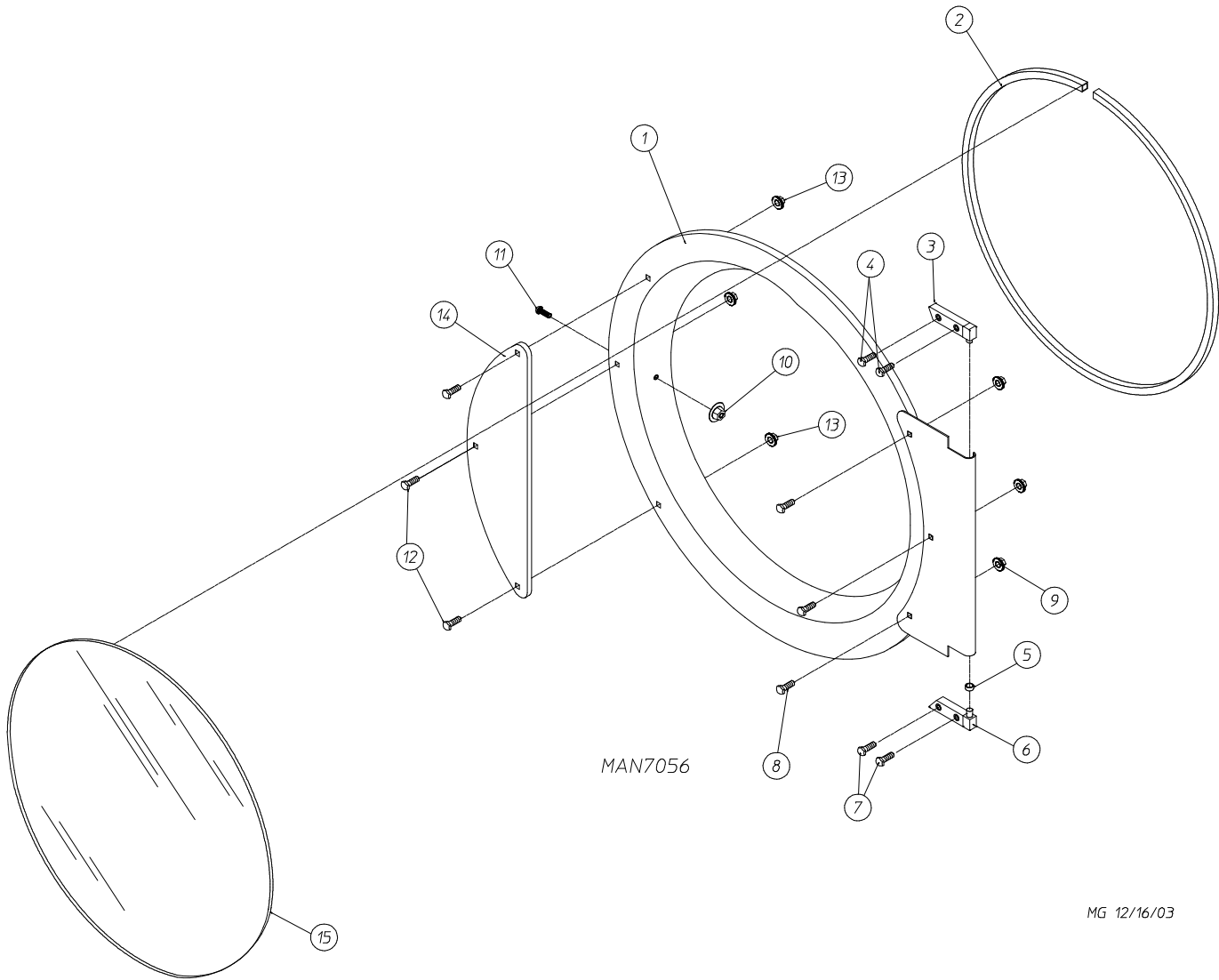

<u>Illus. No.</u>	<u>Part No.</u>	<u>Qty.</u>	<u>Description</u>
1	882740	1	Black Left / Right Coin Box Face Plate ONLY
	882745	1	Left Coin Box with Black Face Plate (less lock)
2	882672	1	Coin Box Lock Kit (includes 2 locks "keyed alike")
3	160136*	1	Coin Box Lock Key ONLY
4	882742	1	Black Left Coin Vault ONLY
5	882740	1	Black Left / Right Coin Box Face Plate ONLY
	882746	1	Right Coin Box with Black Face Plate (less lock)
6	882741	1	Black Right Coin Vault ONLY

* Specify key number when ordering.

LEFT COIN VAULT & ASSEMBLY

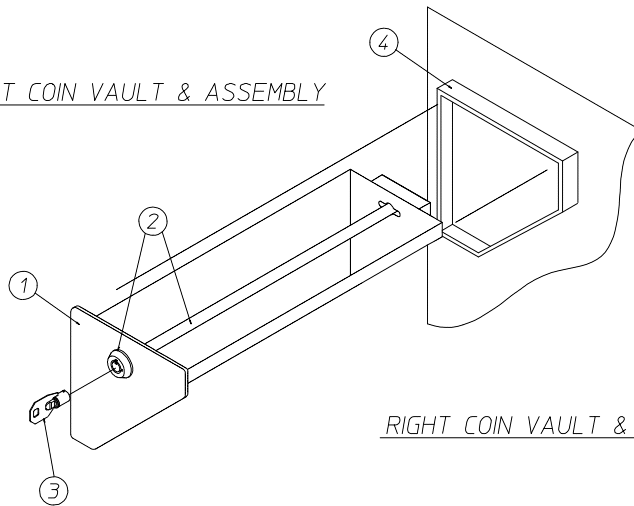

RIGHT COIN VAULT & ASSEMBLY

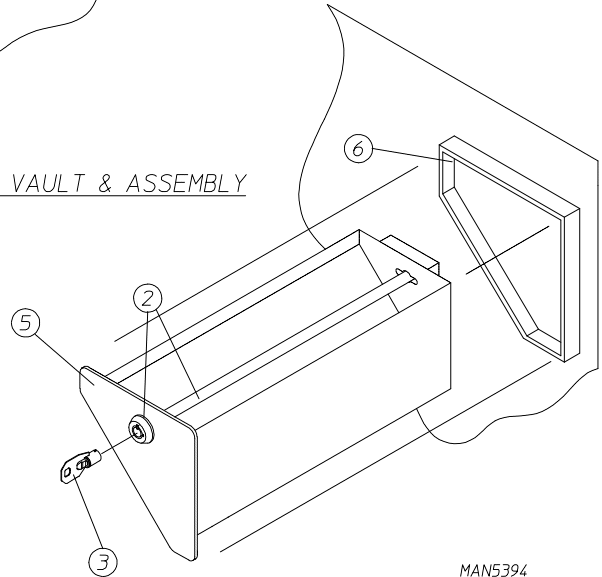

SRS 07/25/00

MAN5394

<u>Illus. No.</u>	<u>Part No.</u>	<u>Qty.</u>	<u>Description</u>
1	881150	1	Black Main Door Assembly Complete (includes illus. nos. 1, 2, and 8 through 15)
	881207	1	Stainless Steel Main Door Assembly Complete (includes illus. nos. 1, 2, and 8 through 15)
2	102354	1	Door Gasket
	170730	1	Clear Glass Adhesive (10.3 oz. cartridge)
	170731	1	Black Glass Adhesive (10.3 oz. cartridge)
3	881152	1	Black Top Hinge Block Assembly (includes illus. nos. 3 and 4)
	881208	1	Stainless Steel Top Hinge Block Assembly
4	150445	2	1/4-20 x 3/4" Black Cap Head Setscrew
5	153031	1	1/4" Nylon Washer
6	881151	1	Black Bottom Hinge Block Assembly (includes illus. nos. 5 through 7)
	881209	1	Stainless Steel Bottom Hinge Block Assembly
7	150445	2	1/4-20 x 3/4" Black Cap Head Setscrew
	150443	2	1/4-20 x 3/4" Stainless Steel Cap Head Setscrew
8	150683	3	1/4-20 x 5/8" Black Carriage Bolt
	150682	3	1/4-20 x 5/8" Stainless Steel Carriage Bolt (for models with stainless steel doors)
9	152014	3	1/4-20 Free Spin Wash Nut
10	151010	1	#10-32 Black Hex Acorn Nut
	151009	1	#10-32 Stainless Steel Hex Acorn Nut
11	150120	1	Door Latch Screw
12	150683	3	1/4-20 x 5/8" Black Carriage Bolt
	150682	3	1/4-20 x 5/8" Stainless Steel Carriage Bolt (for models with stainless steel doors)
13	152014	3	1/4-20 Free Spin Wash Nut
14	881210	1	Black Main Door Handle ONLY
	170333	1	Stainless Steel Main Handle ONLY
15	102211	1	Door Glass

Main Door Switch Assembly

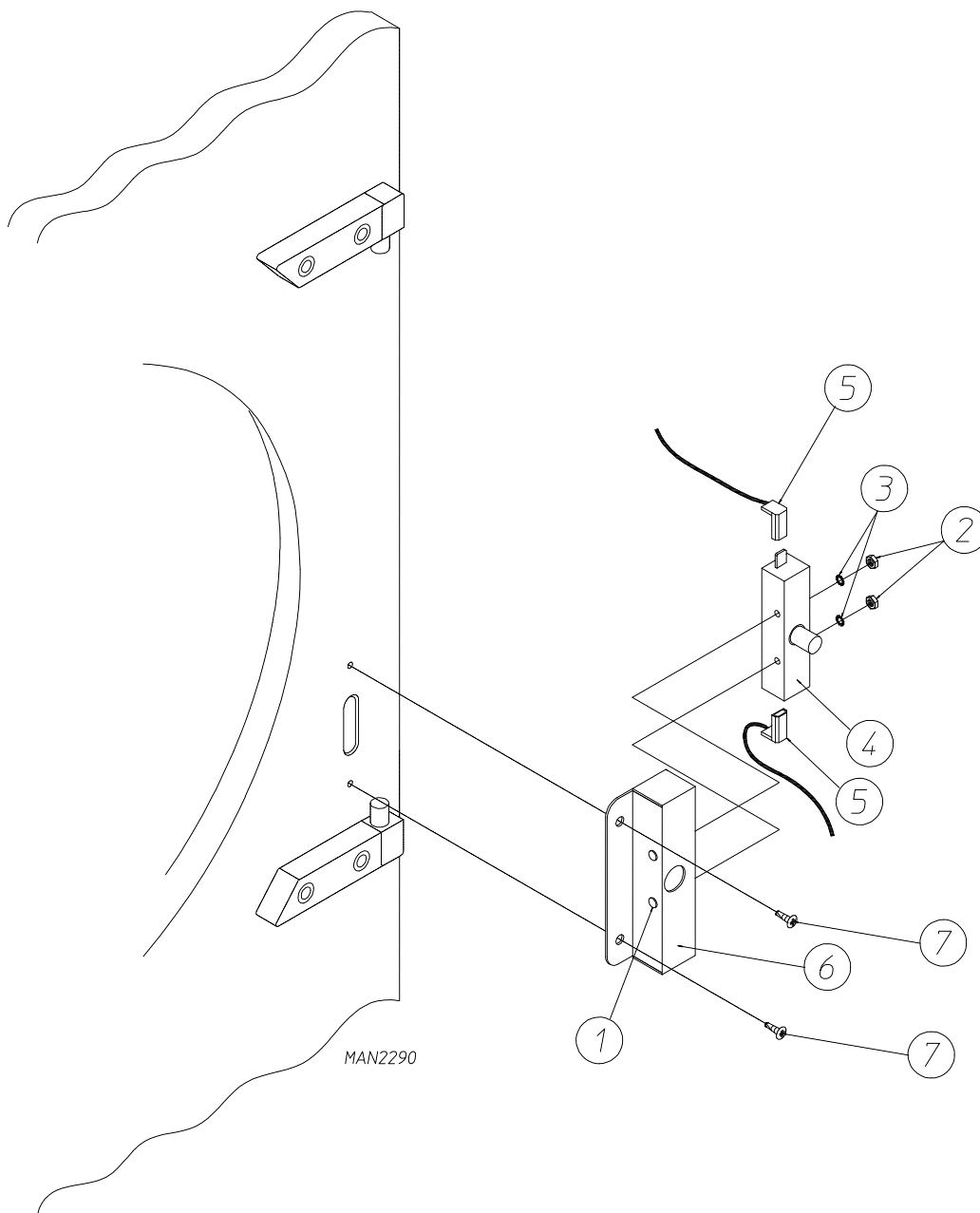

<u>Illus. No.</u>	<u>Part No.</u>	<u>Qty.</u>	<u>Description</u>
1	153566	2	#6-32 x 7/8" Clinch Stud
2	152013	2	#6-32 Hex Nut
3	153010	2	#6 Internal / External Star Washer
4	137005	1	Door Switch
5	122636	2	Flag Terminal
6	881211	1	Black Main Door Switch Housing ONLY
	353209	1	Stainless Steel Main Door Switch Housing ONLY
	881153	1	Black Main Door Switch Housing Complete (includes illus. nos. 1 through 4 and 6)
	800474	1	Stainless Steel Main Door Switch Housing Complete (includes illus. nos. 1 through 4 and 6)
7	150301	2	#8-18 x 7/16" Phillips Pan Head TEK Screw

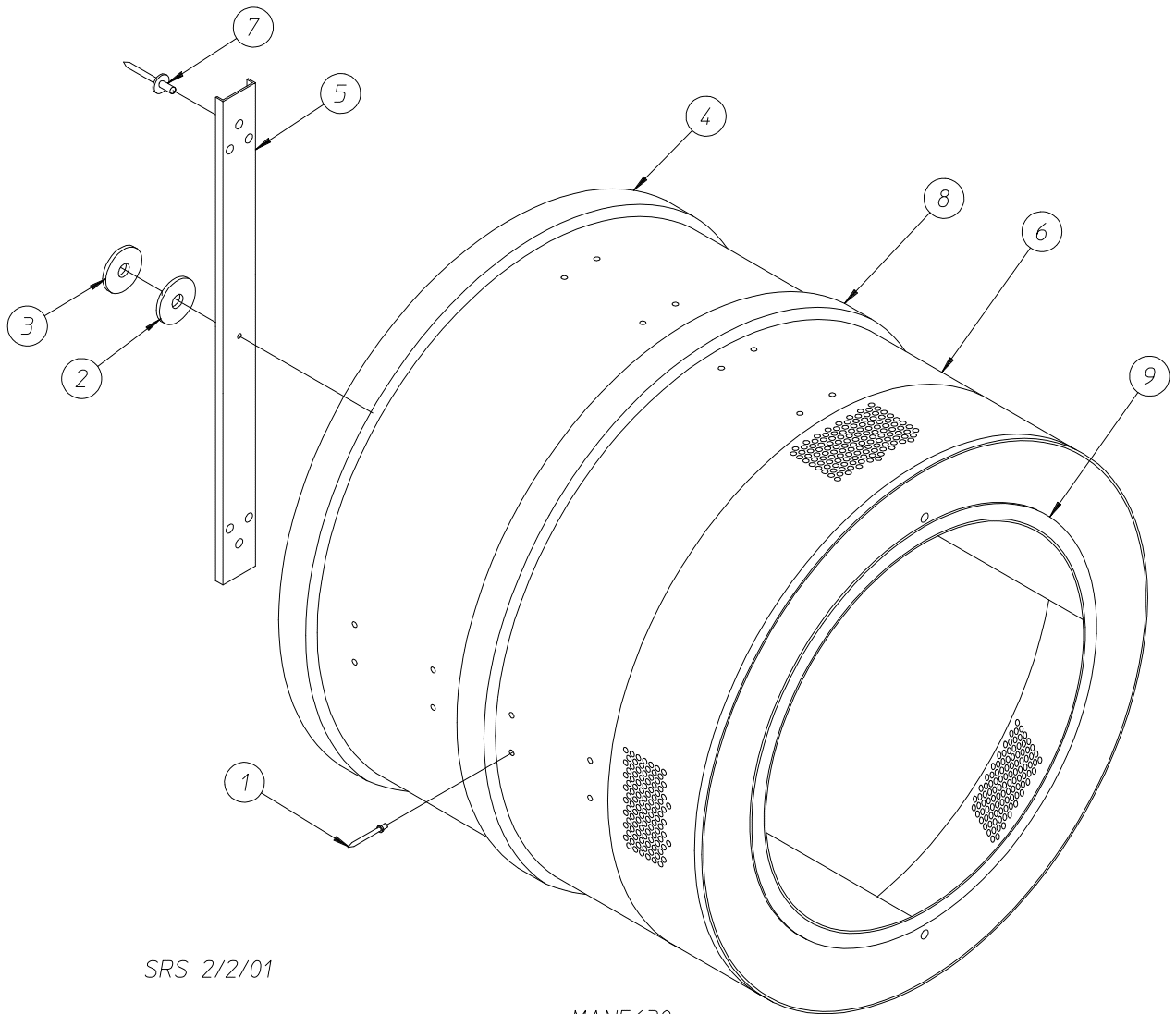

SRS 2/2/01

MAN5630

<u>Illus. No.</u>	<u>Part No.</u>	<u>Qty.</u>	<u>Description</u>
1	154210	40	5/32" x 3/16" Pop Rivet
2	354217	1	Spacer Plate
3	153048	1	Inner Friction Teflon® Pad
4	116332	1	94" x 2-1/2" x 1/8" Felt Collar
5	882765	1	One Arm Tumbler Support Assembly (includes illus. nos. 2, 3, and 5)
6	860101	1	Tumbler Assembly for One Arm Tumbler Support (includes illus. nos. 1, 4, and 9)
7	154210	6	5/32" x 3/16" Pop Rivet
8	100191	1	12 Rib 105" Long (J) High Temperature Belt
9	115907	1	Inner Ring Felt Collar
	401010	1	#847 Adhesive for Felt Collar (5 oz. tube)

Top Locking Lint Basket Assembly

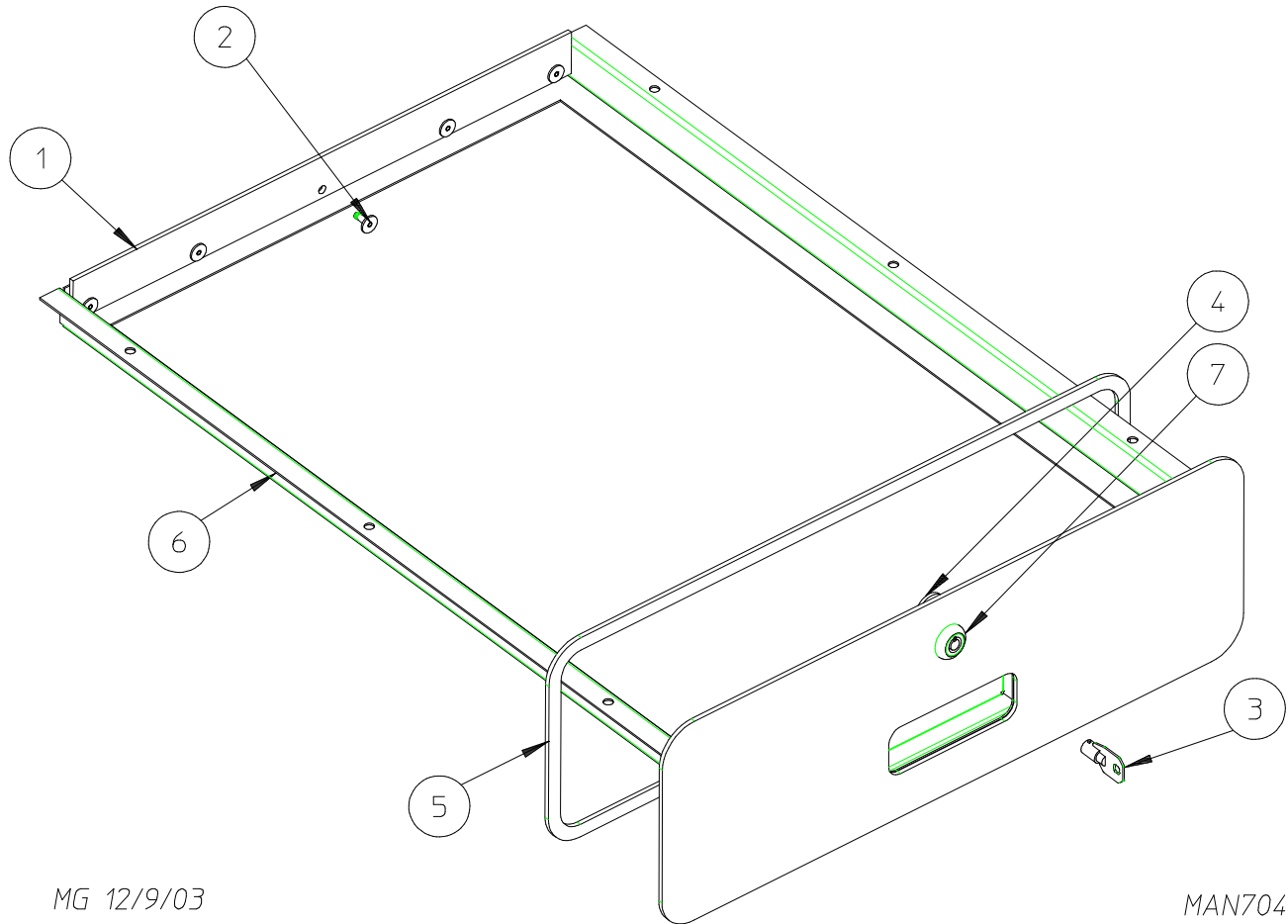

MG 12/9/03

MAN7044

<u>Illus. No.</u>	<u>Part No.</u>	<u>Qty.</u>	<u>Description</u>
1	115904	1	Lint Basket Felt
2	154210	5	5/32" x 3/16" Pop Rivet
3	160140	1	Key ONLY for XX4451
4	160066	1	1/16" Offset x 1-1/8" Long Cam
5	117605	4	1/4" x 3/8" Neoprene Sponge Tape (sold by the foot)
6	882787	1	Top Locking Lint Basket with Lock (white) (includes illus. nos. 1 through 7)
7	160038	1	Lint Basket Lock with Cam (no key)
	160050	1	Lint Basket Lock (no cam and key) for Stainless Steel ONLY

Bottom Locking Lint Basket Assembly

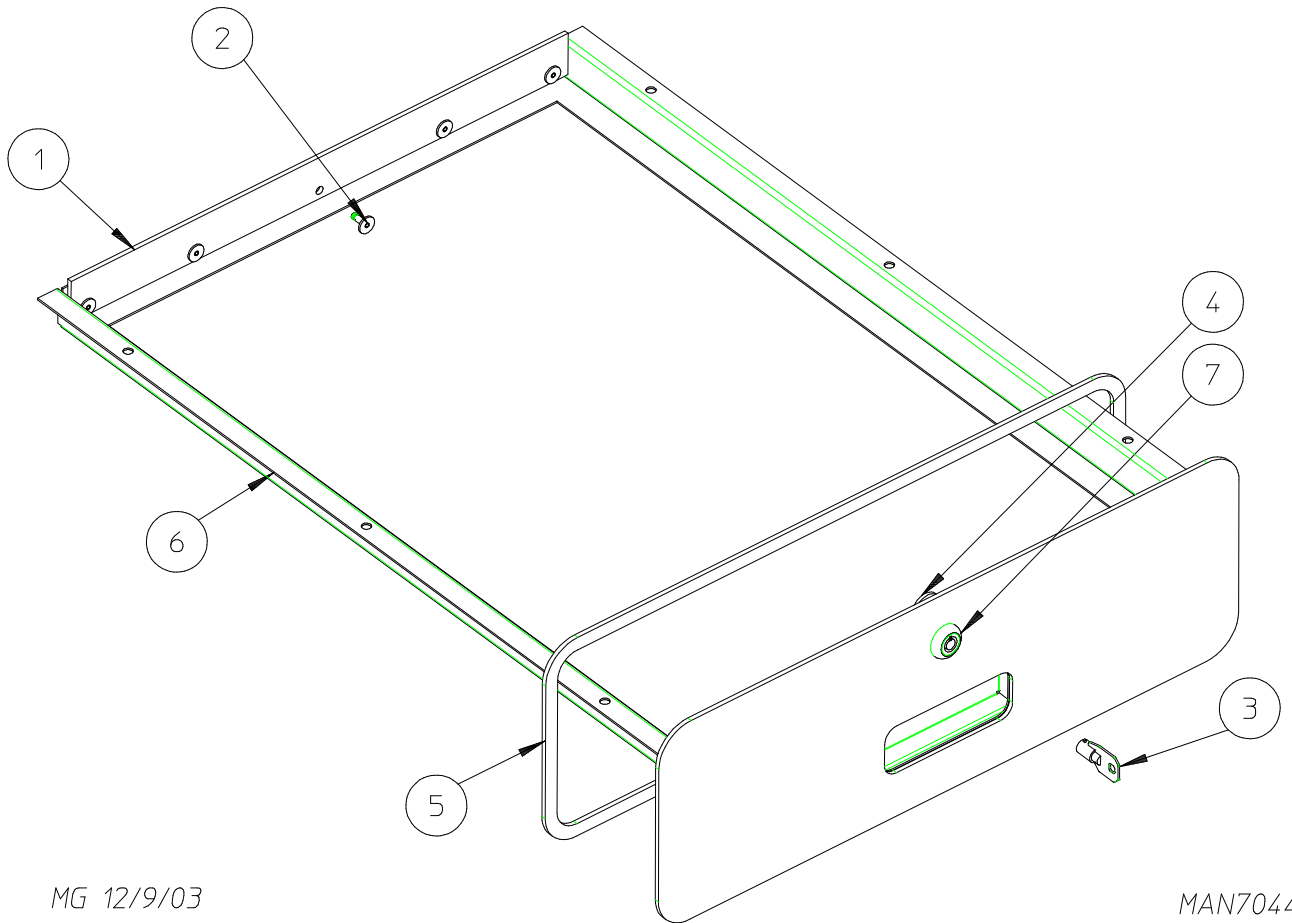

MG 12/9/03

MAN7044

<u>Illus. No.</u>	<u>Part No.</u>	<u>Qty.</u>	<u>Description</u>
1	115904	1	Lint Basket Felt
2	154210	5	5/32" x 3/16" Pop Rivet
3	160140	1	Key ONLY for XX4451
4	160066	1	1/16" Offset x 1-1/8" Long Cam
5	117604	4	1/8" x 3/8" Neoprene Sponge Tape (sold by the foot)
6	882797	1	Bottom Locking Lint Basket Assembly with Lock (black) (includes illus. nos. 1 through 7)
7	160038	1	Lint Basket Lock with Cam (no key)

Top Lint Basket Assembly

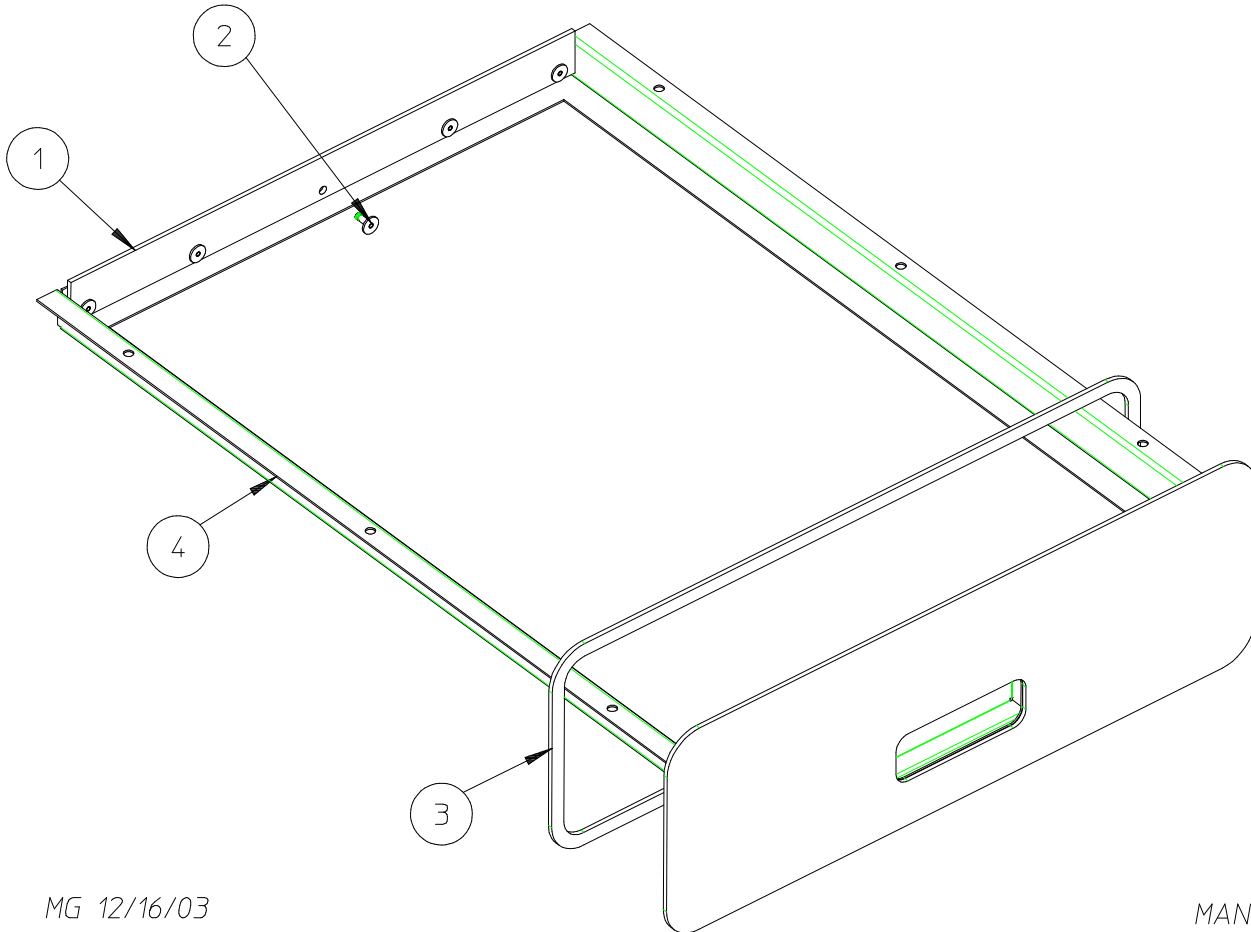

MG 12/16/03

MAN7062

<u>Illus. No.</u>	<u>Part No.</u>	<u>Qty.</u>	<u>Description</u>
1	115904	1	Lint Basket Felt
2	154210	5	5/32" x 3/16" Pop Rivet
3	117604	4	1/4" x 3/8" Neoprene Sponge Tape (sold by the foot)
4	884123	1	White Lint Basket Assembly (includes illus. nos. 1 through 4)

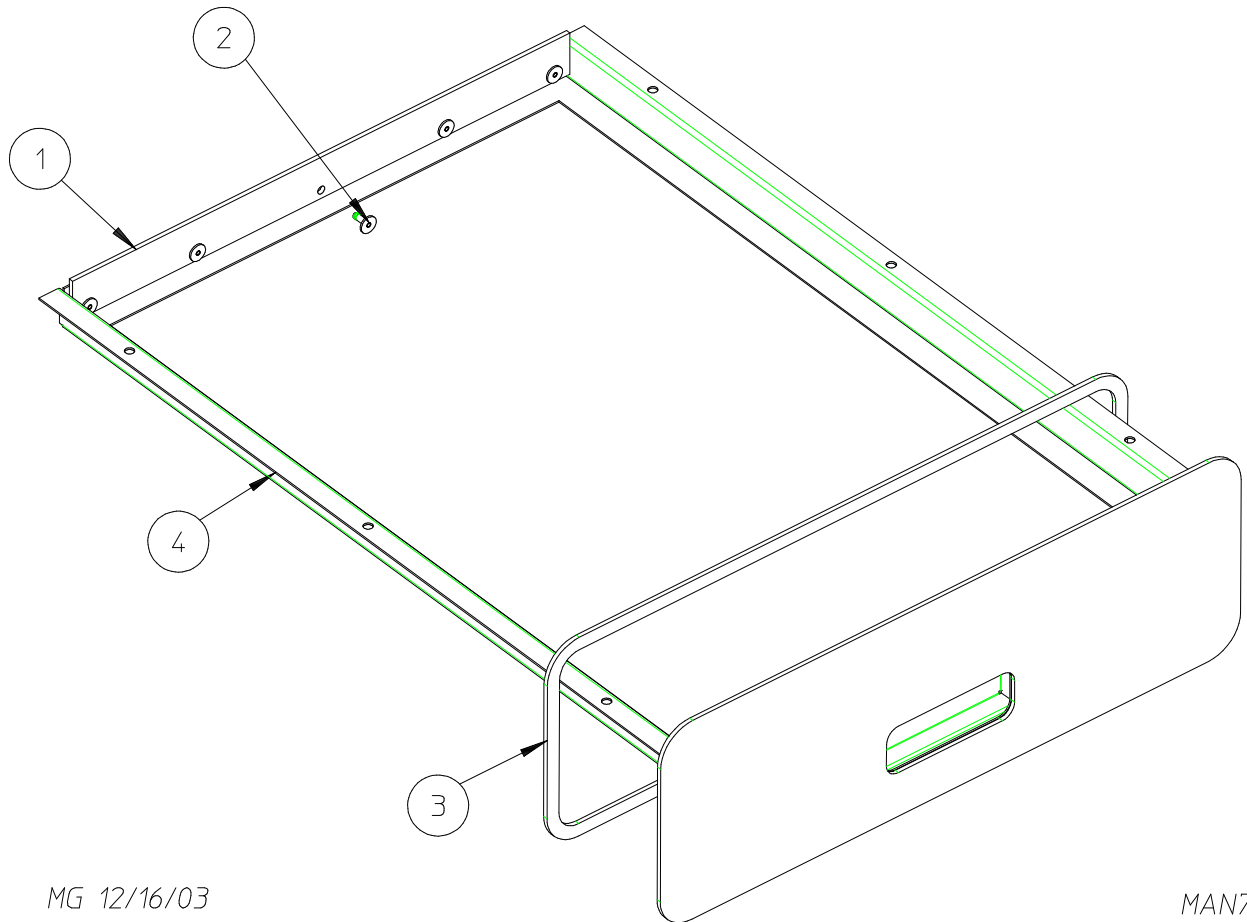

MG 12/16/03

MAN7062

<u>Illus. No.</u>	<u>Part No.</u>	<u>Qty.</u>	<u>Description</u>
1	115904	1	Lint Basket Felt
2	154210	5	5/32" x 3/16" Pop Rivet
3	117605	4	1/4" x 3/8" Neoprene Sponge Tape (sold by the foot)
4	884122	1	Black Lint Basket Assembly (includes illus. nos. 1 through 4)

Separator Assembly

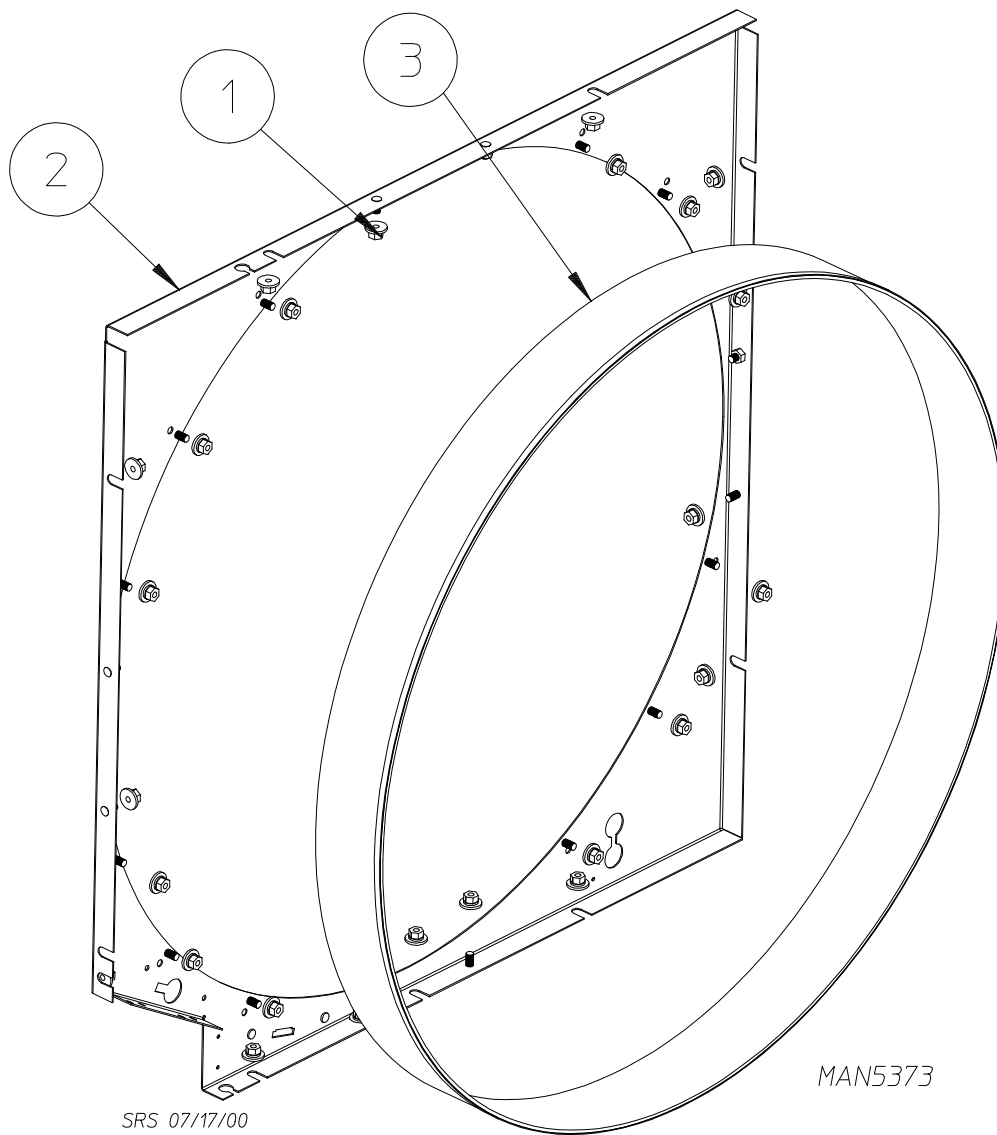

<u>Illus. No.</u>	<u>Part No.</u>	<u>Qty.</u>	<u>Description</u>
1	152014	18	1/4-20 Free Spin Wash Nut
2	882926	1	Inner Ring Separator Bracket
	882717	1	Inner Ring Separator Assembly (includes illus. nos. 1 through 3)
3	115903	1	Tumbler Separation Felt

Rotational Sensor / Sail Switch and Teflon® Backup Washer Plate

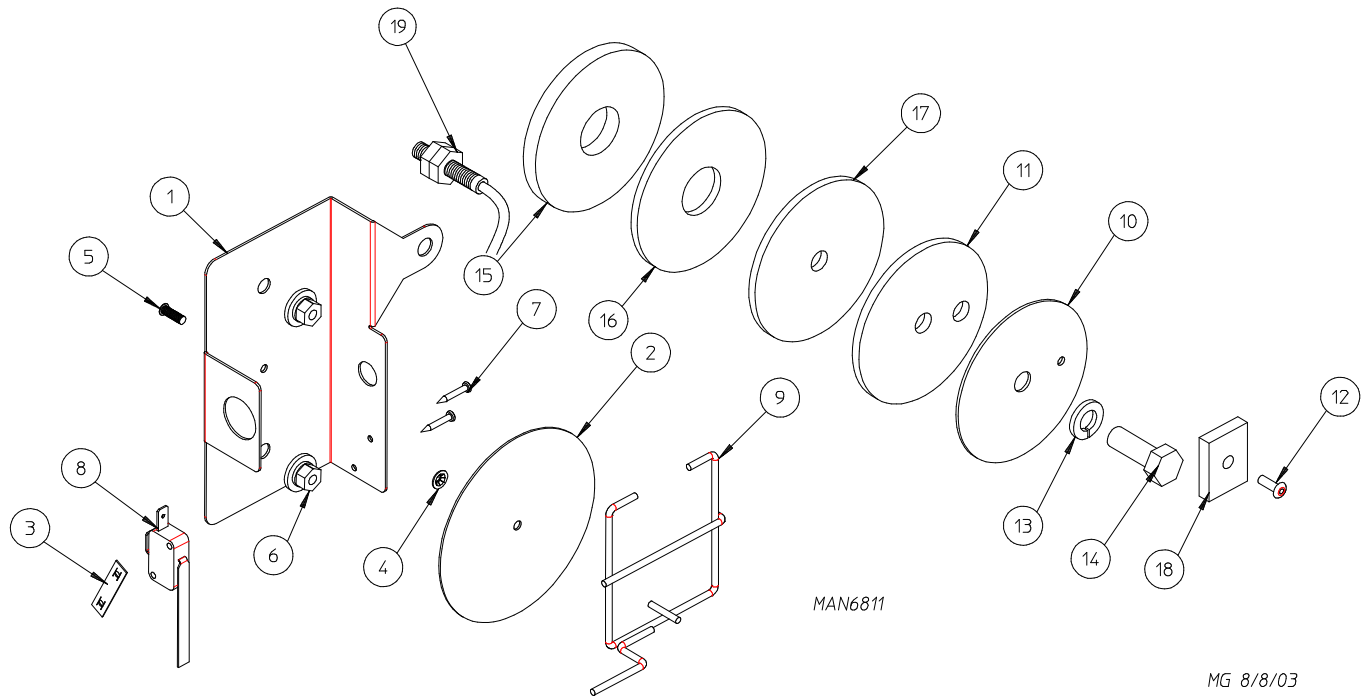

<u>Illus. No.</u>	<u>Part No.</u>	<u>Qty.</u>	<u>Description</u>
1	353283	1	Rotational Sensor Bracket
2	319202	1	Sail Switch Flat Damper
3	154004	1	Tinnerman Twin Speed Nut
4	154002	1	1/8" Push-On Fastener
5	153528	1	8/32" x 1/2" Self-Clinching Stud
6	152014	2	1/4-20 Free Spin Wash Nut
7	150303	2	Phillips Pan Head Screw
8	122200	1	Sail Switch
9	105550	1	Sail Switch Rod
	883934	1	Teflon® Backup Washer and Magnet Assembly (includes illus. nos. 10 through 12, 17, and 18)
10	353282	1	Thrust Bearing Backup Washer
11	353281	1	Backup Washer Rivet Spacer
12	154218	1	1/8" Diameter Aluminum Rivet
13	153053	1	5/16" Lock Washer
14	150640	1	5/16-18 x 7/8" Hex Bolt
15	354217	1	Plate Spacer
16	153048	1	Inner Friction Pad
17	153047	1	Outer Teflon® Friction Pad
18	102102	1	1" x 3/4" x 0.197" Door Magnet
19	822735	1	Phase 7 Rotational Sensor Switch

Lint Coop and Adjustment Wheel Bracket Assembly

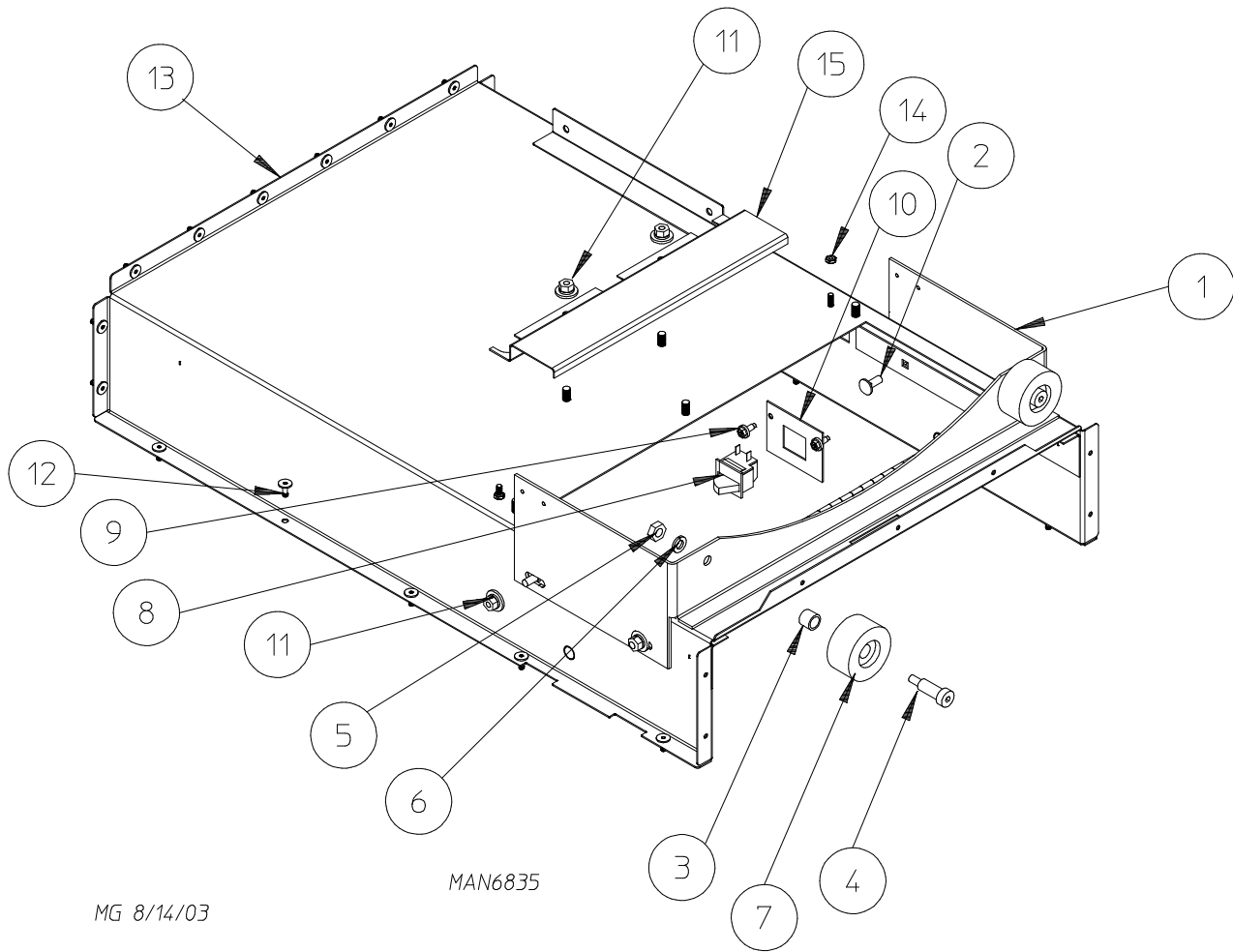

<u>Illus. No.</u>	<u>Part No.</u>	<u>Qty.</u>	<u>Description</u>
1	354067	1	Thrust Wheel Mount
2	150682	4	1/4-20 x 5/8" Stainless Steel Carriage Bolt
3	154284	2	Tumbler Wheel Spacer
4	154267	2	M10 x 25 mm Shoulder Screw
5	154013	2	M8 Hex Nut
6	153002	2	5/16" Split Lock Washer
7	180050	2	Duratred Idler Wheel
8	122002	1	Arcoelectric Door Switch
9	150309	2	#10-16 x 1/2" Hex Head TEK Crimptite Screw
10	354156	1	Lint Switch Bracket
11	152014	6	1/4-20 Free Spin Wash Nut
12	154210	20	5/32" x 3/16" Pop Rivet
13	854029	1	Lint Coop
14	152001	2	#8-32 x 3/8" Hex Nut
15	354171	1	Harness Stiffener

Left Rear Wheel Bracket (3-Bolt)

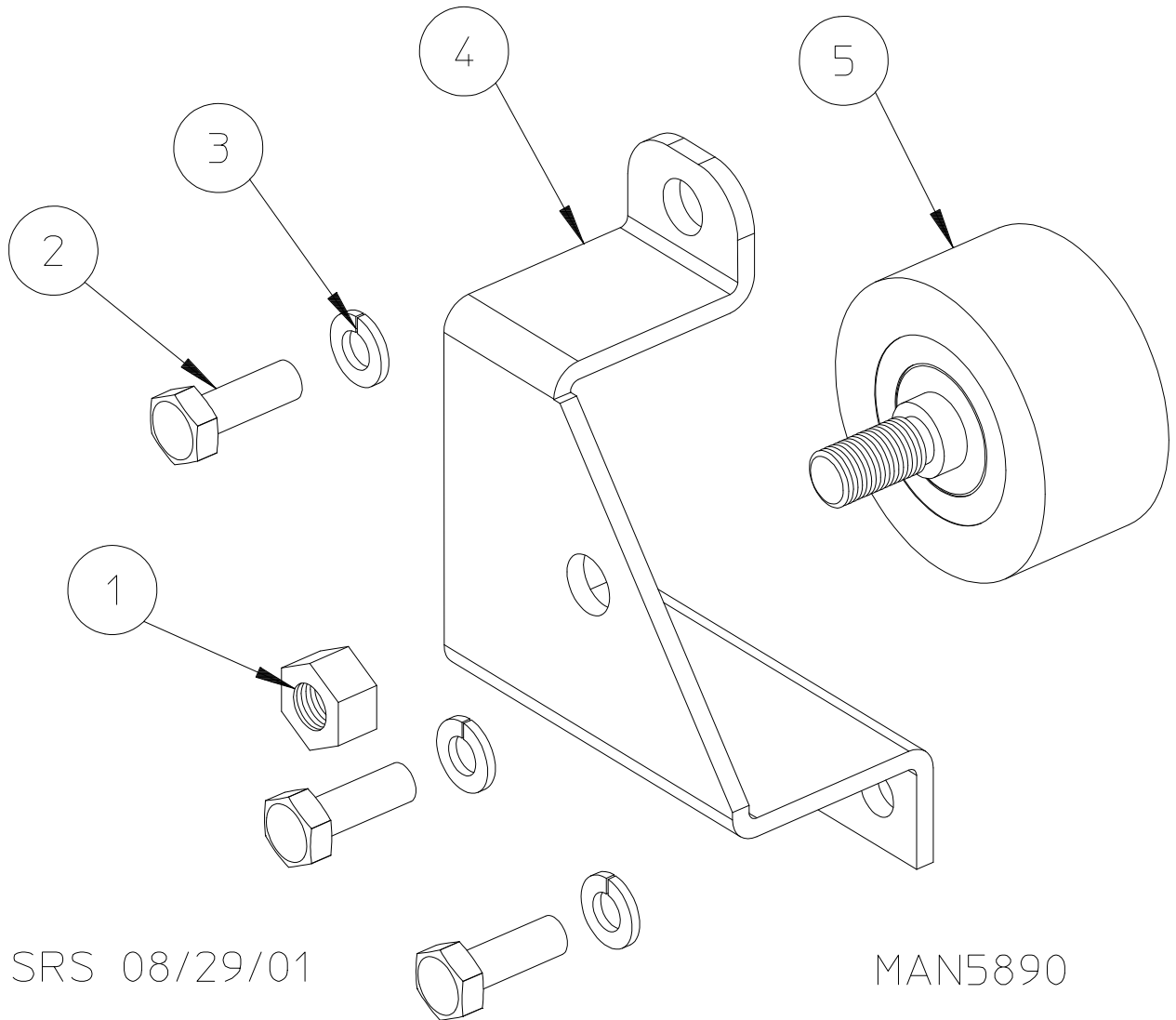

<u>Illus. No.</u>	<u>Part No.</u>	<u>Qty.</u>	<u>Description</u>
1	150220	1	3/8-24 Hex Nut
2	150510	3	1/4-20 x 3/4" Hex Head Machine Bolt
3	153007	3	1/4" Split Lock Washer
4	883004	1	Left Rear Roller Wheel Bracket ONLY (3-bolt)
	883125	1	Left Rear Roller Wheel Bracket Assembly with Hardware (3-bolt)
5	180050	1	Thruster Wheel

Right Rear Wheel Bracket (3-Bolt)

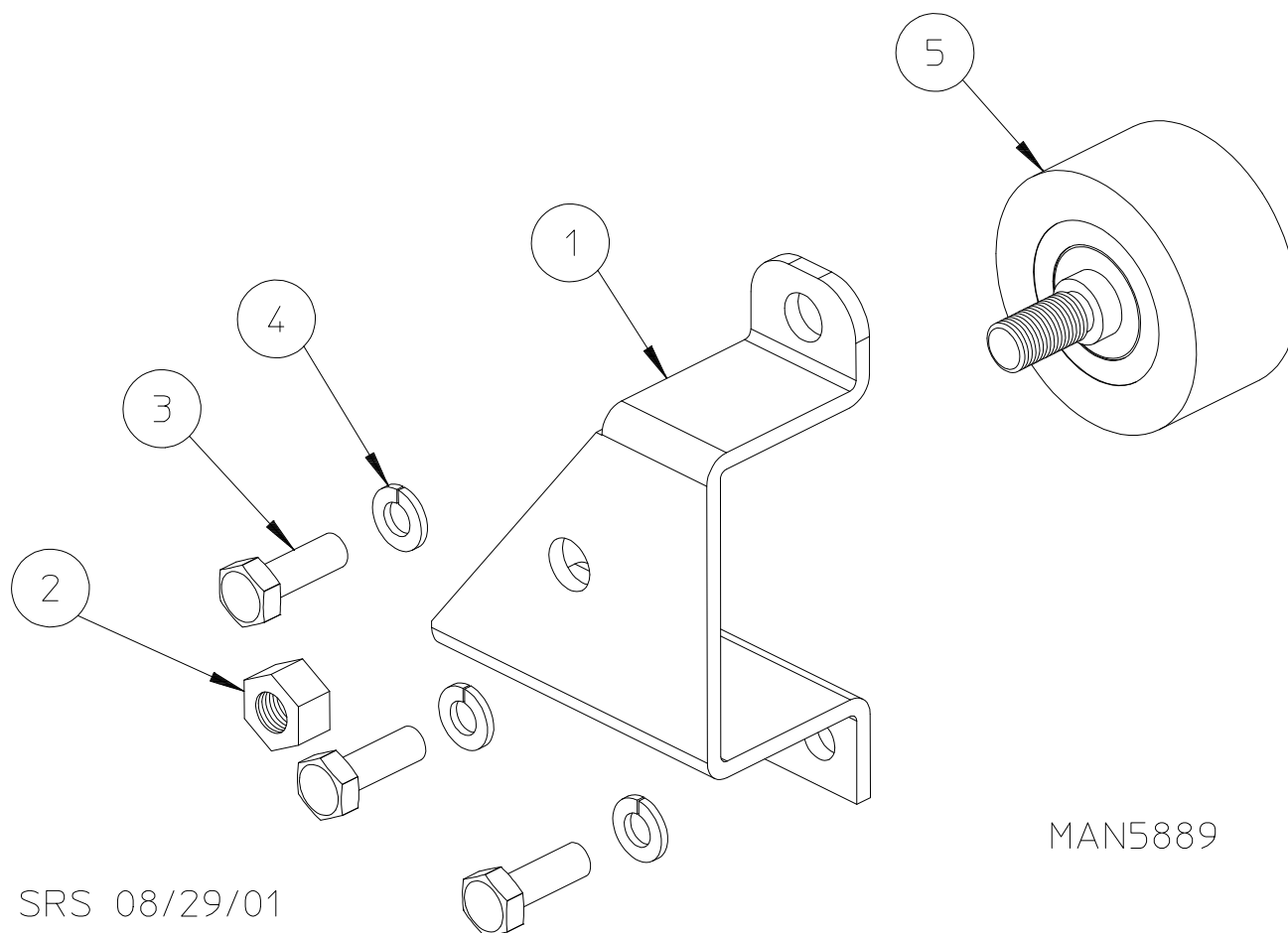

<u>Illus. No.</u>	<u>Part No.</u>	<u>Qty.</u>	<u>Description</u>
1	883005	1	Right Rear Roller Wheel Bracket ONLY (3-bolt)
	883126	1	Right Rear Roller Wheel Bracket Assembly with Hardware (3-bolt)
2	150220	1	3/8-24 Hex Nut
3	150510	3	1/4-20 x 3/4" Hex Head Machine Bolt
4	153007	3	1/4" Split Lock Washer
5	180050	1	Thruster Wheel

Microprocessor Temperature Sensor Bracket Assembly

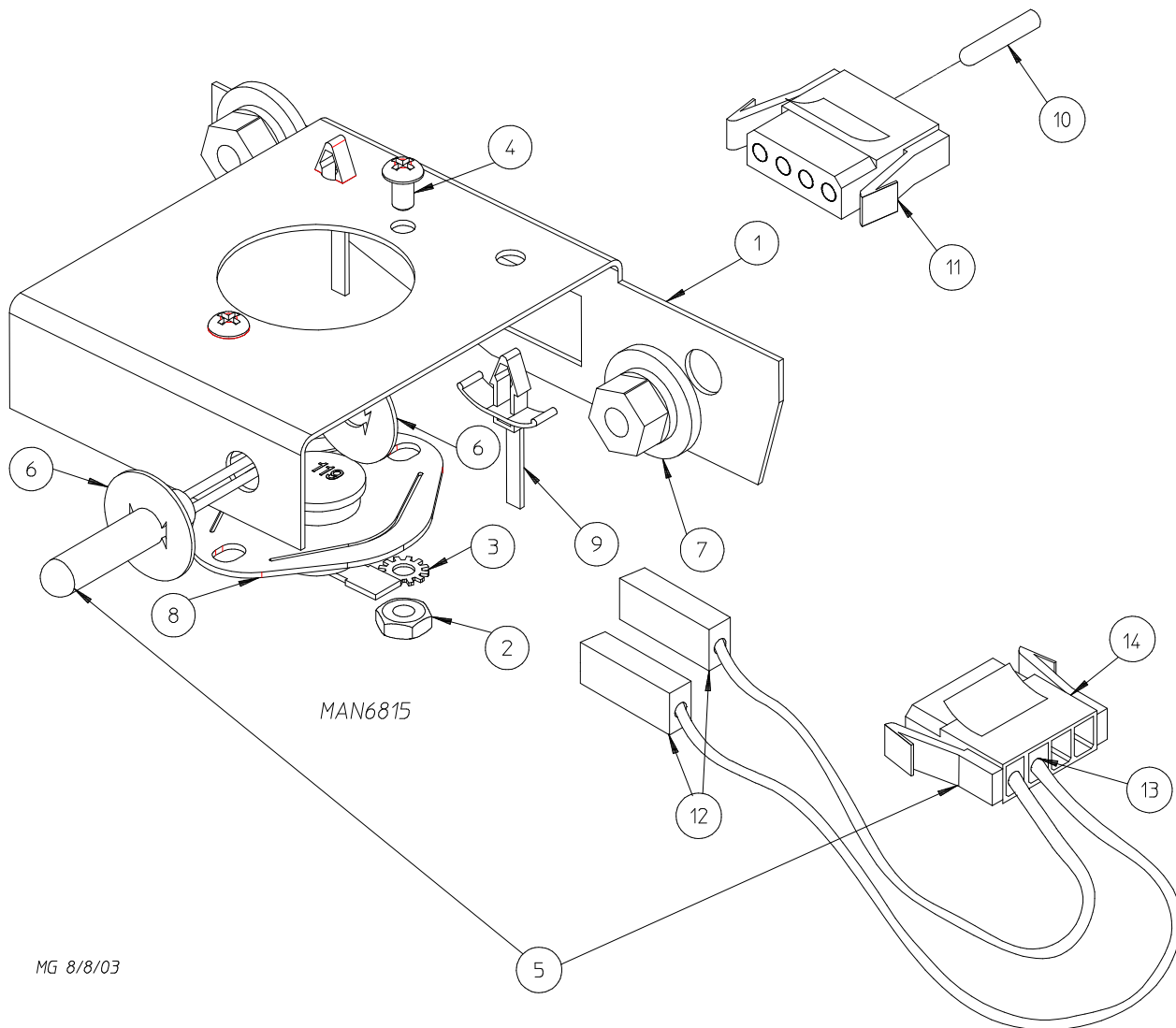

<u>Illus. No.</u>	<u>Part No.</u>	<u>Qty.</u>	<u>Description</u>
1	882682	1	Temperature Sensor Bracket Assembly Complete (includes illus. nos. 1 through 6, 8, and 12 through 14)
	354117	1	Sensor Bracket ONLY
2	152013	2	#6-32 Hex Nut
3	153010	2	#6 Star Washer
4	150005	2	#6-32 x 1/4" Phillips Round Head Machine Screw
5	883025	1	Microprocessor Temperature Sensor Probe Assembly (includes illus. nos. 5, 6, and 12 through 14)
6	154007	2	1/4" Push-On Fastener
7	152014	2	1/4-20 Free Spin Wash Nut
8	130119	1	Temperature Sensor
9	121494	2	3/16" Push Mount Wire Tie
10	122700	4	Pin Terminal ONLY
11	122604	1	4-Position Connectors (male)
12	121028	2	1/4" Push-On Terminal
13	122701	4	Socket Terminal ONLY
	122801	-	Pin / Socket Extraction Tool...Not Illustrated
14	122605	1	4-Position Connectors (female)

Top Burner Box Assembly

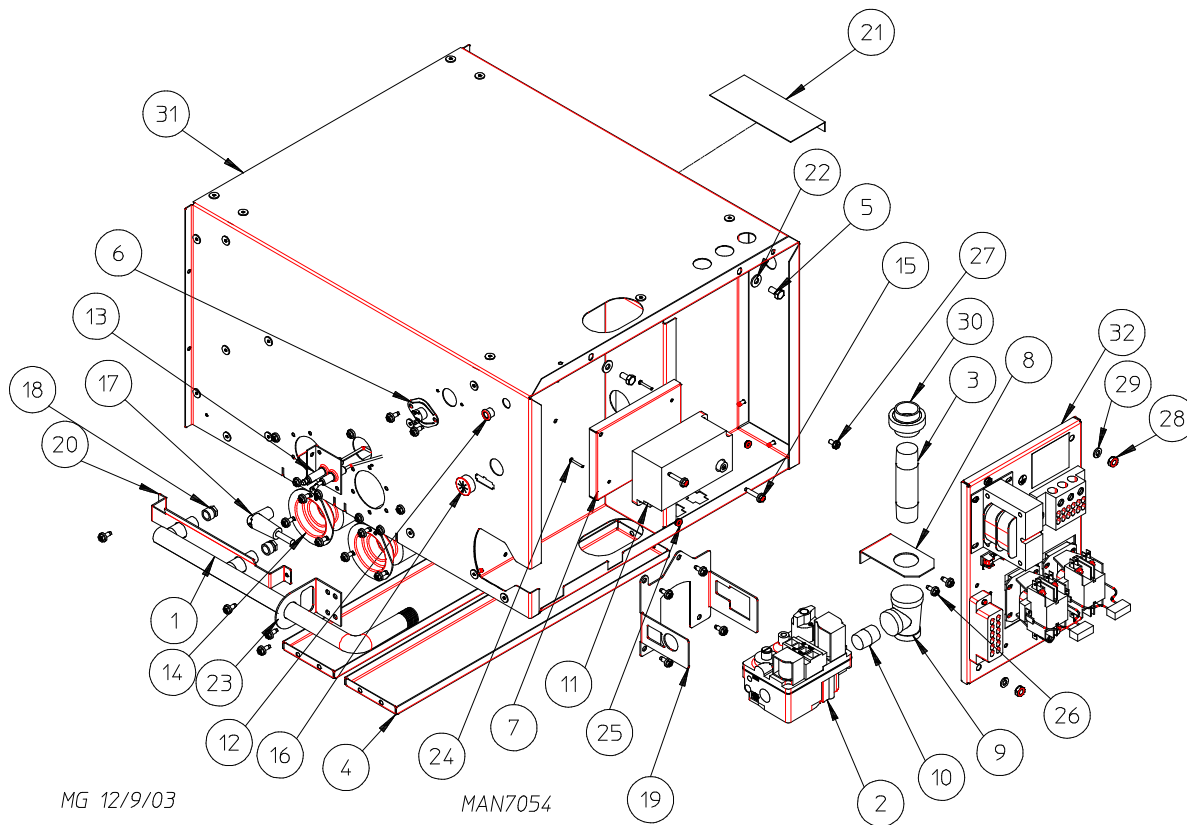

<u>Illus. No.</u>	<u>Part No.</u>	<u>Qty.</u>	<u>Description</u>
1	141138	1	Two Port Burner Manifold
2	887274	1	1/2" 24 VAC (natural gas) Gas Valve
3	142710	1	3/4" x 4" Black Nipple
4	354146	2	Bottom Burner Baffle
5	150512	2	1/4-20 x 1/2" Hex Head Machine Bolt
6	130400	1	Burner Hi Limit
7	354162	1	Direct Spark Ignition Module Mounting Panel
8	354163	1	Pipe Bracket
9	142505	1	3/4" x 1/2" x 1/2" Tee
10	142700	1	1/2" Close Nipple
11	884280	1	Direct Spark Ignition Johnson Control
12	121300	1	Open / Closed Bushing
13	128915	1	Ignition with Flame Probe Orange
14	141137	2	Stainless Steel Burner Tube
15	150299	2	#10 x 1" Hex Washer TEK Screw
16	121400	1	7/8" Universal Bushing
17	128919	1	36" Ignition Cable
18	884141	1	H.V. Wiring (gray) with Spade Connector
	140844	2	Burner Orifice
19	354049	1	Gas Valve Mounting Bracket
20	354100	1	Manifold Support
21	354170	1	Burner Tube Hood
22	153018	2	1/4" Flat Washer
23	318700	1	Small Burner Tube Bracket
24	153562	2	#6-32 x 3/4" Black Self-Clinching Stud
25	152013	2	#6-32 Hex Nut
26	150309	31	#10-16 x 1/2" Hex Head TEK Crimptite Screw
27	120910	1	Green Ground Screw
28	152002	2	1/4-20 Hex Nut
29	153007	2	1/4" Split Lock Washer
30	142601	1	3/4" Black Union
31	860073	1	Phase 7 Burner Box

Bottom Burner Box Assembly

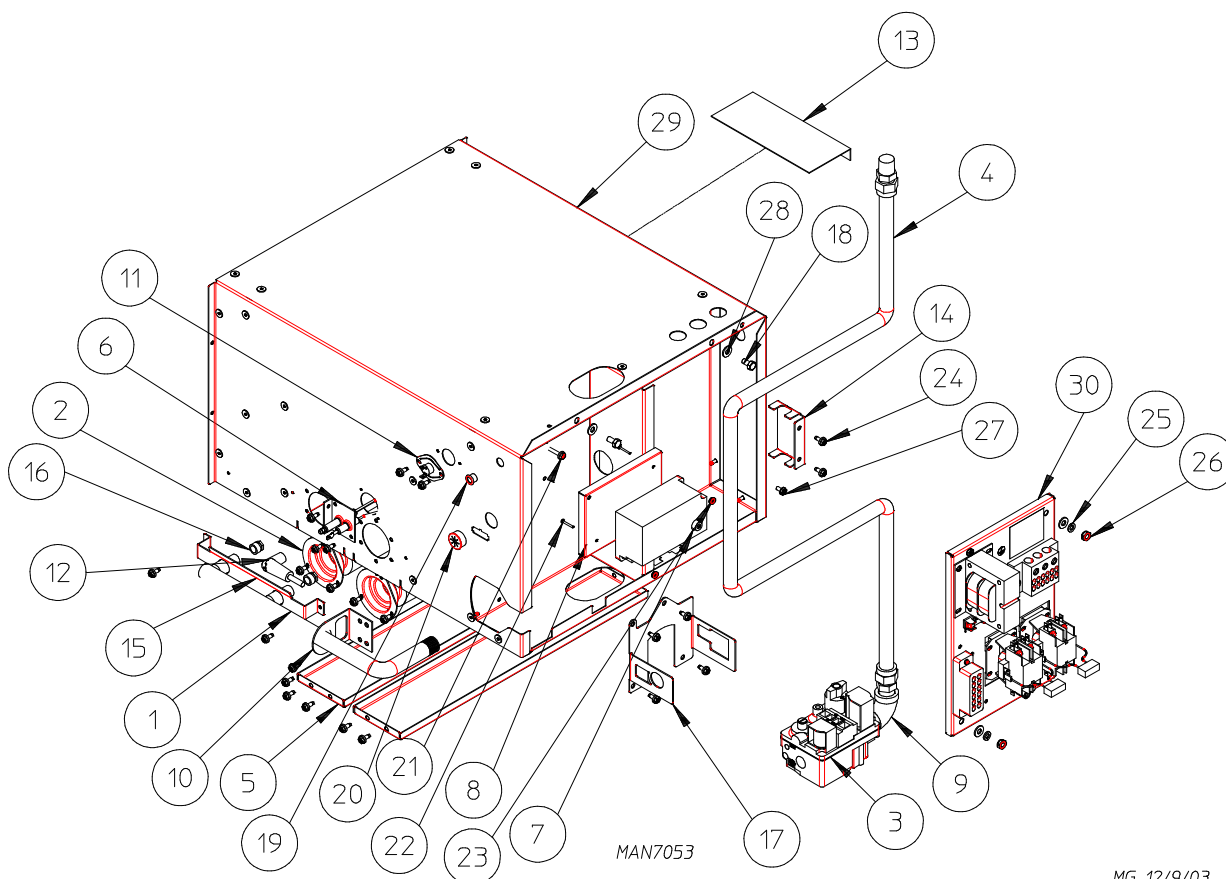

MG 12/9/03

<u>Illus. No.</u>	<u>Part No.</u>	<u>Qty.</u>	<u>Description</u>
1	141138	1	Two Port Burner Manifold
2	141137	2	Stainless Steel Burner Tube
3	882774	1	1/2" 24 VAC (natural gas) Gas Valve
4	143118	1	1/2" x 1/2" x 60" Stainless Steel Flex Hose
5	354146	2	Bottom Burner Baffle
6	128915	1	Ignition with Flame Probe
7	801048	1	Direct Spark Ignition Johnson Control
8	354162	1	Direct Spark Ignition Module Mounting Panel
9	142506	1	1/2" x 1/2" Street Elbow
10	318700	1	Small Burner Tube Bracket
11	130400	1	Burner Hi-Limit
12	128919	1	36" Ignition Cable
13	884141	1	H.V. Wiring with (gray) Spade Connector
14	354170	1	Burner Tube Hood
15	354261	1	Flexible Gas Line Bracket
16	354100	1	Manifold Support
17	140844	2	Burner Orifice
18	354049	1	Gas Valve Mounting Bracket
19	150512	2	1/4-20 x 1/2" Hex Head Machine Bolt
20	121300	1	Open / Closed Bushing
21	121400	1	7/8" Universal Bushing
22	150299	2	#10 x 1" Hex Washer TEK Screw
23	153562	2	#6-32 x 3/4" Black Self-Clinching Stud
24	152013	2	#6-32 Hex Nut
25	150309	29	#10-16 x 1/2" Hex Head TEK Crimptite Screw
26	153007	2	1/4" Split Lock Washer
27	152002	2	1/4-20 Hex Nut
28	120910	1	Green Ground Screw
29	153018	4	1/4" Flat Washer
30	860073	1	Phase 7 Burner Box

Blower Motor Assembly

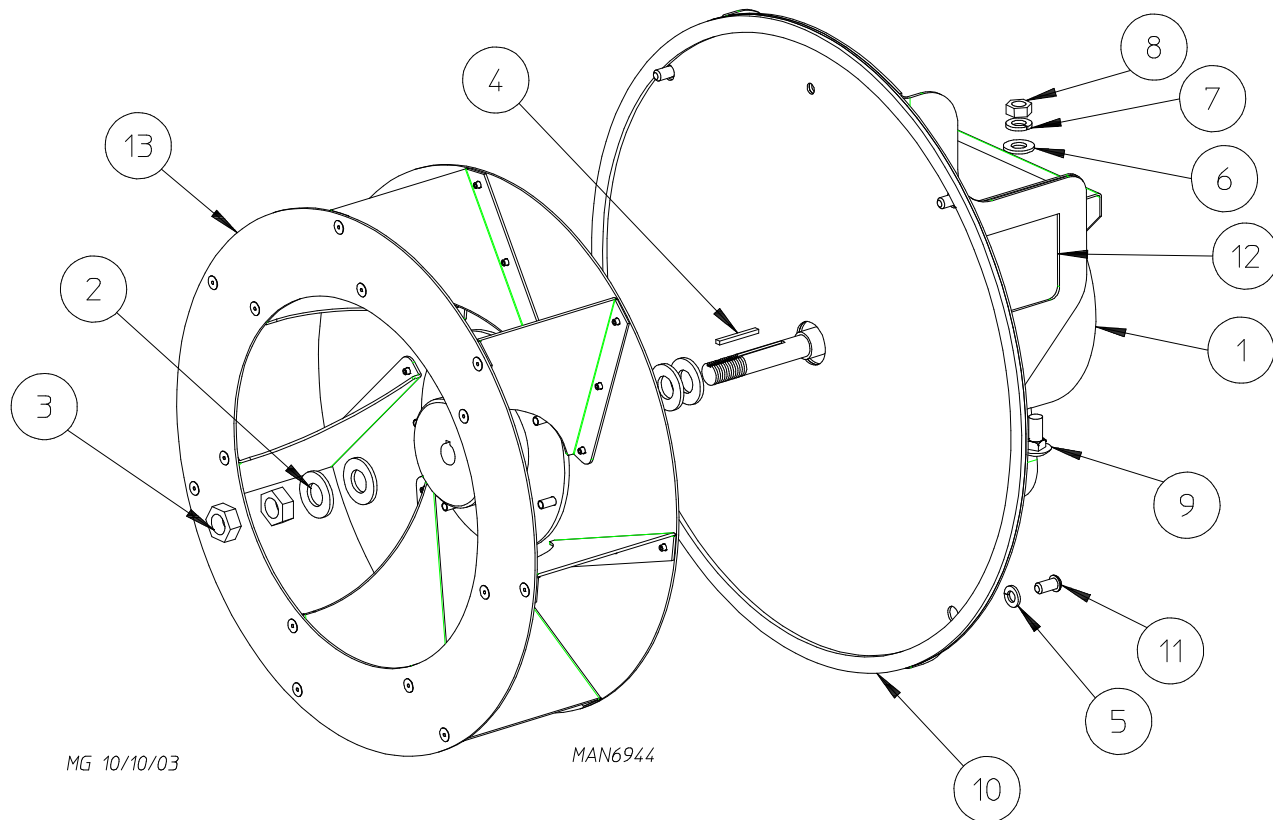

<u>Illus. No.</u>	<u>Part No.</u>	<u>Qty.</u>	<u>Description</u>
1	181038	1	1/4 hp 115/230v/60 Hz Blower Motor
2	153050	4	1/2" x 1-1/16" Flat Washer
3	152006	2	1/2-20 Left-Hand Jam Nut
4	100731	1	1/8" x 3/32" x 1-1/8" Key
5	153007	4	1/4" Split Lock Washer
6	153001	4	5/16" Flat Washer
7	153002	4	5/16" Split Lock Washer
8	152004	4	5/16-18 Hex Nut
9	154279	4	5/16-18 x 3/4" Carriage Bolt
10	117604	1	1/8" x 3/8" Neoprene Sponge Tape (sold by the foot)
11	150111	4	1/4-20 x 1/2" Phillips Round Head Machine Screw
12	884039	1	Blower Motor Mount ONLY
13	802029	1	12-1/2" Riveted Impellor with 1/2" Bore
	884040	1	Blower Motor and Mount Assembly Complete (includes illus. nos. 1 through 13)

Rear Electrical Panel (Top and Bottom)

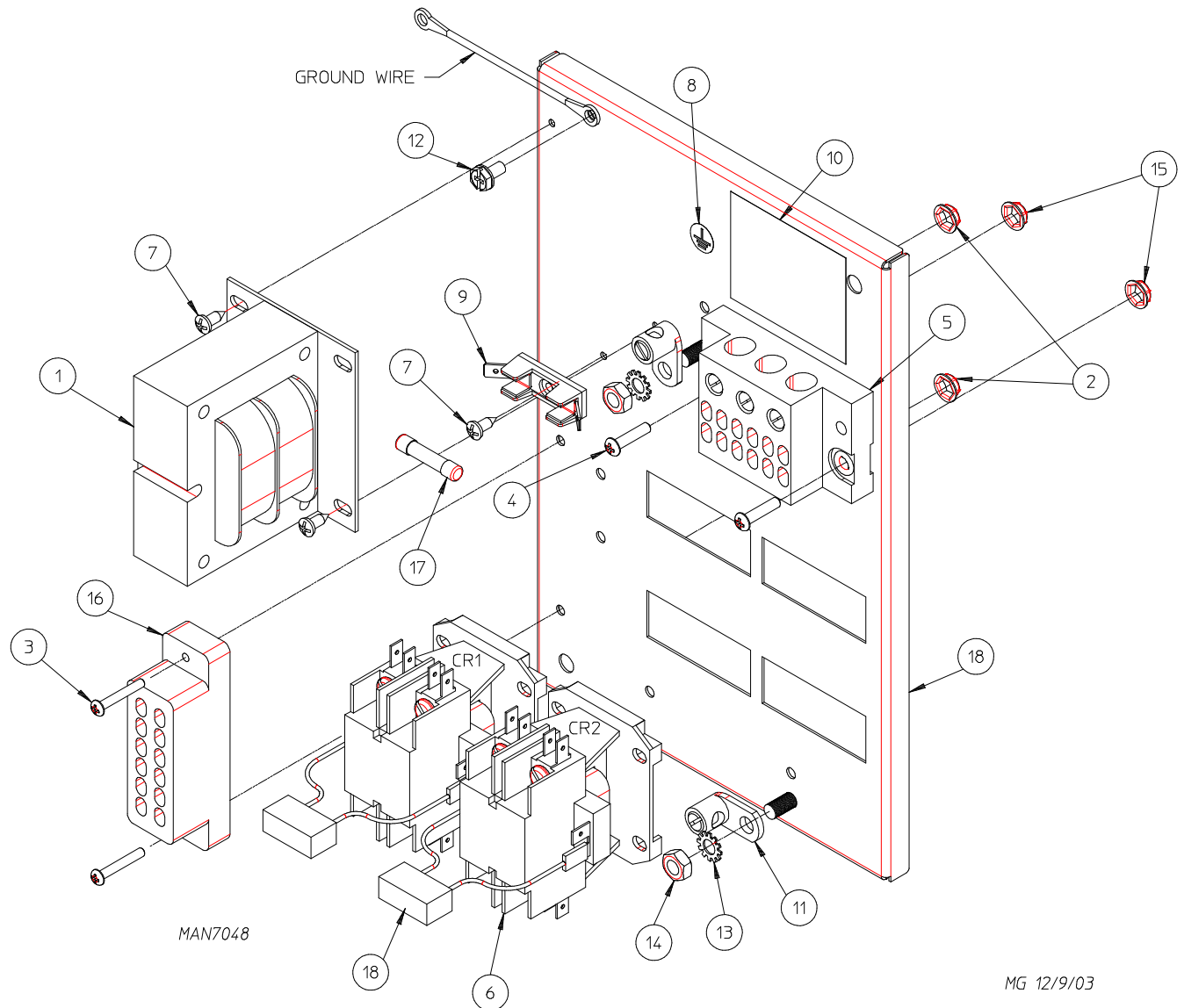

<u>Illus. No.</u>	<u>Part No.</u>	<u>Qty.</u>	<u>Description</u>
1	860063	1	Transformer Assembly
2	151000	2	#6-32 Pal Nut
3	150002	2	#6-32 x 1" Phillips Round Head Screw
4	150103	2	#8-32 x 3/4" Phillips Round Head Machine Screw
5	120714	1	Quick Connect Power Block
6	132498	2	Double Pole 24v Contactor
7	150301	3	#8-18 x 7/16" Phillips Pan Head TEK Screw
8	112075	1	Ground Label
9	136008	1	Fuse Holder
10	114103	1	Electrical Service Label
11	121010	1	L-70 14-4 Terminal Lug
12	120910	1	Green Ground Screw
13	153021	2	1/4" External / Internal Shakeproof Washer
14	152002	2	1/4-20 Hex Nut
15	151001	2	#8-32 Pal Nut
16	120712	1	12 Position Block 250v 25A
17	136049	1	3/4-Amp (Slo-Blo) Fuse
18	824828	2	R.C. Network Assembly

Drive Motor / Motor Mount Assemblies

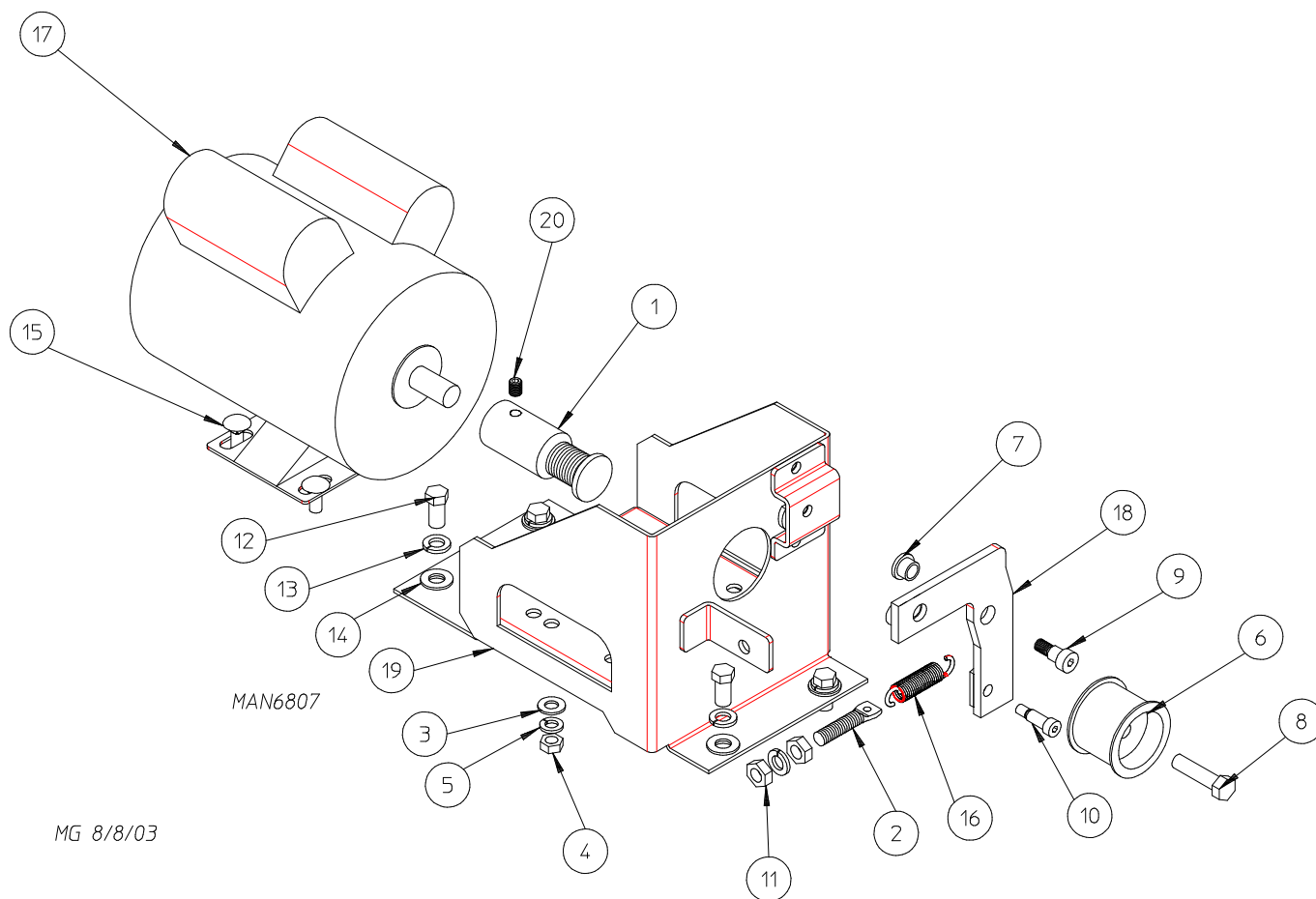

<u>Illus. No.</u>	<u>Part No.</u>	<u>Qty.</u>	<u>Description</u>
1	354263	1	Sheave
2	154274	1	3/8-16 x 2-1/4" Long Spade Bolt
3	153001	4	5/16" Flat Washer
4	152004	4	5/16-18 Hex Nut
5	153002	4	5/16" Split Lock Washer
6	100250	1	Efson Back Side Idler Assembly
7	121350	1	13/32" x 3/8" I.D. Bronze Bushing
8	150600	1	3/8-16 x 1-1/2" Hex Head Tap Bolt
9	154266	1	5/16-18 x 3/8" x 3/8" Shoulder Screw
10	154276	1	1/4-20 x 1/4" x 5/8" Shoulder Bolt
11	152005	2	3/8-16 Hex Nut
12	150508	4	3/8-16 x 3/4" Hex Machine Bolt
13	153005	5	3/8" Split Lock Washer
14	153004	4	3/8" x 1" O.D. Flat Washer
15	154279	4	5/16-18 x 3/4" Carriage Bolt
16	157010	1	1-7/8" Extension Spring
17	884371	1	1/4 hp 115v 60 Hz Motor
18	854014	1	Idler Arm
19	854012	1	Motor Mount
20	154321	1	5/16-24 x 3/8" Allen Setscrew

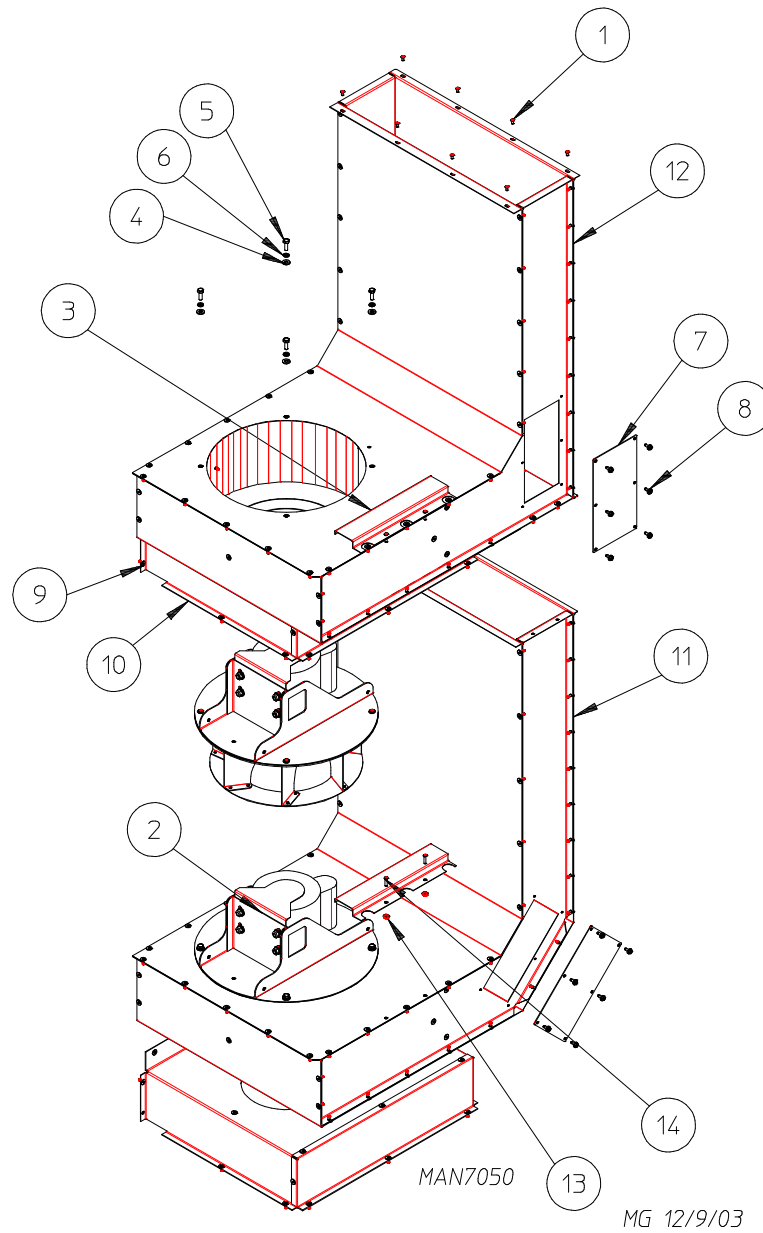

<u>Illus. No.</u>	<u>Part No.</u>	<u>Qty.</u>	<u>Description</u>
1	154200	8	5/32" Pop Rivet
2	860098	2	Blower Motor Assembly with Riveted Impellor
3	354171	2	Harness Stiffener
4	153018	8	1/4" Flat Washer
5	150510	8	1/4-20 x 3/4" Hex Head Machine Bolt
6	153007	8	1/4" Split Lock Washer
7	354078	2	Exhaust Access Plate
8	150309	12	#10-16 x 1/2" Hex Head TEK Screw
9	154210	43	5/32" x 3/16" Pop Rivet
10	854015	2	Air Plenum Assembly
11	854051	1	Lower Blower Housing
12	854049	1	Upper Blower Housing
13	151001	1	#8-32 Pal Nut
14	150103	4	#8-32 x 3/4" Phillips Round Head Machine Screw

Rear Back Guard Assembly

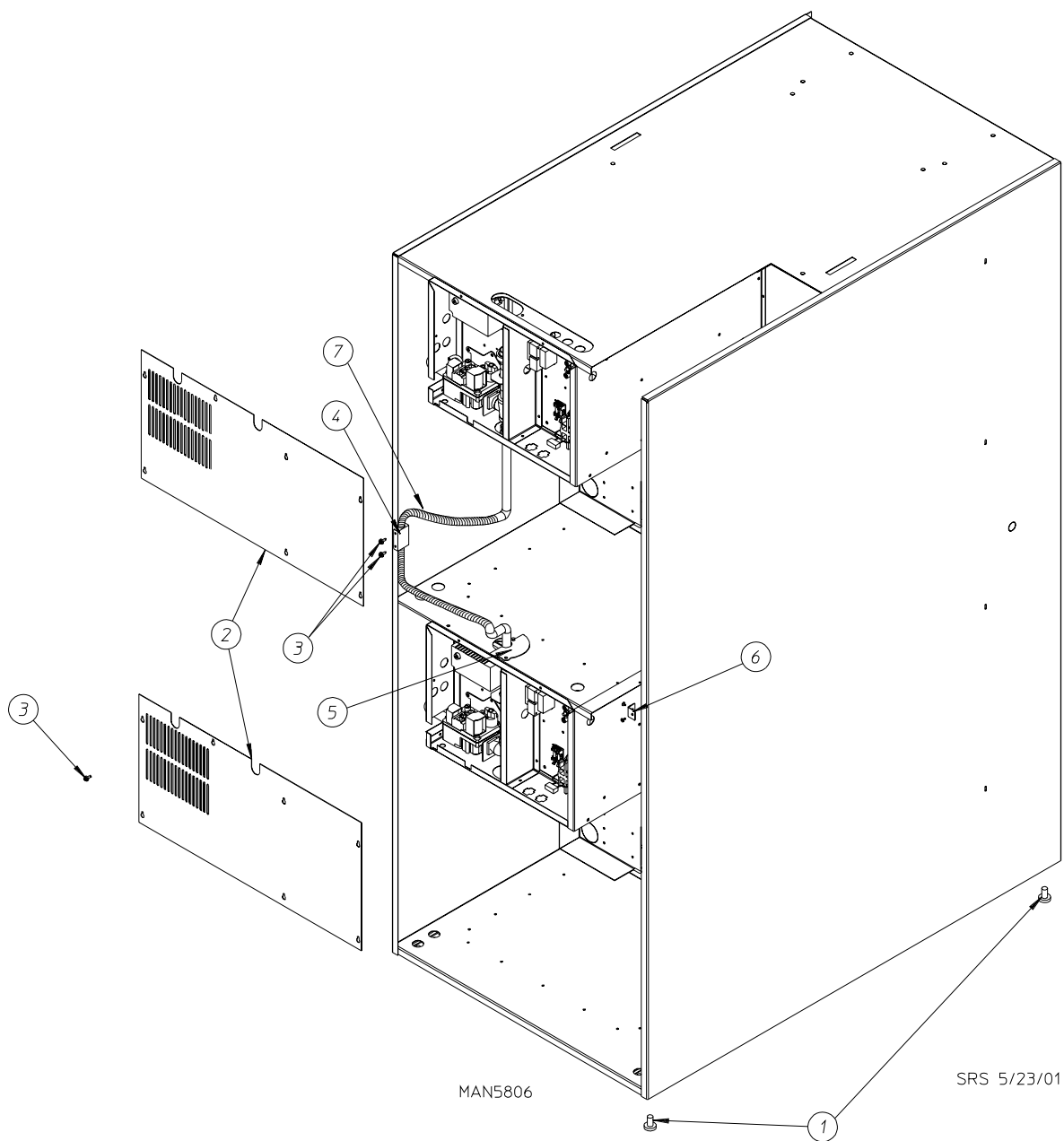

<u>Illus. No.</u>	<u>Part No.</u>	<u>Qty.</u>	<u>Description</u>
1	103500	4	Leveling Leg
2	883070	2	Back Guard Short
3	150300	12	#10-16 x 1/2" TEK Screw
4	883071	1	Top Pocket Flex Gas Line Bracket
5	883160	1	Bottom Pocket Flex Gas Line Pivot Support
6	883073	1	Rear Right Side Panel Support Assembly
7	143118	1	1/2" x 1/2" x 60" Stainless Steel Flex Hose

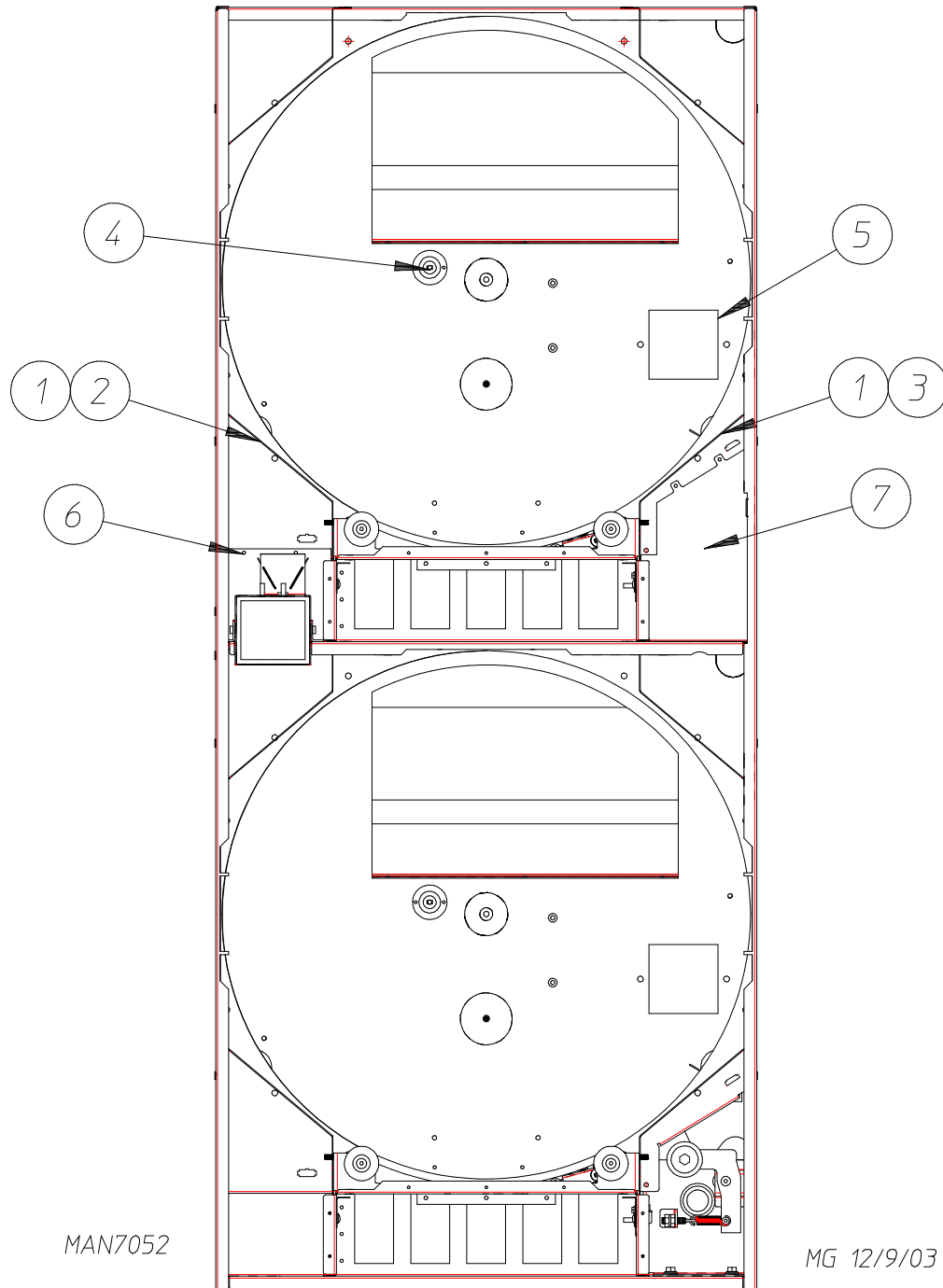

<u>Illus. No.</u>	<u>Part No.</u>	<u>Qty.</u>	<u>Description</u>
1	102310	4	Wrapper Gasket (sold by the foot)
	401010	1	3M Mastic
2	860045	1	Left Wrapper Assembly
3	860044	1	Right Wrapper Assembly
4	852319	1	Axial Sensor Probe Assembly
5	354243	1	Inner Back Cover Plate
6	360155	1	Left Side Air Blockage Plate
7	360153	1	Right Side Air Blockage Plate

