



AD-78 / ML-78
Parts Manual
Phase 7 / Dual Timer
With F.S.S. / S.A.F.E. Options

American Dryer Corporation
88 Currant Road
Fall River MA 02720-4781 USA
Telephone: +1 (508) 678-9000 / Fax: +1 (508) 678-9447
e-mail: techsupport@amdry.com

www.amdry.com

Retain This Manual In A Safe Place For Future Reference

American Dryer Corporation products embody advanced concepts in engineering, design, and safety. If this product is properly maintained, it will provide many years of safe, efficient, and trouble free operation.

ONLY qualified technicians should service this equipment.

OBSERVE ALL SAFETY PRECAUTIONS displayed on the equipment or specified in the installation manual included with the dryer.

The following “**FOR YOUR SAFETY**” caution must be posted near the dryer in a prominent location.

FOR YOUR SAFETY

Do not store or use gasoline or other flammable vapors and liquids in the vicinity of this or any other appliance.

POUR VOTRE SÉCURITÉ

Ne pas entreposer ni utiliser d'essence ni d'autres vapeurs ou liquides inflammables à proximité de cet appareil ou de tout autre appareil.

We have tried to make this manual as complete as possible and hope you will find it useful. ADC reserves the right to make changes from time to time, without notice or obligation, in prices, specifications, colors, and material, and to change or discontinue models.

Important

For your convenience, log the following information:

DATE OF PURCHASE _____ MODEL NO. _____

RESELLER'S NAME _____

Serial Number(s) _____

Replacement parts can be obtained from your reseller or the ADC factory. When ordering replacement parts from the factory, you can FAX your order to ADC at (508) 678-9447 or telephone your order directly to the ADC Parts Department at (508) 678-9000. Please specify the dryer model number and serial number in addition to the description and part number, so that your order is processed accurately and promptly.

The illustrations on the following pages may not depict your particular dryer exactly. The illustrations are a composite of the various dryer models. Be sure to check the descriptions of the parts thoroughly before ordering.

“IMPORTANT NOTE TO PURCHASER”

Information must be obtained from your local gas supplier on the instructions to be followed if the user smells gas. These instructions must be posted in a prominent location near the dryer.

Table of Contents

Phase 7 Non-Coin Microprocessor Control Door Assembly for Models Mfd. as of July 11, 2002	4
Control Door Assembly for Models Mfd. prior to July 11, 2002	5
Phase 7 Non-Coin Microprocessor Control Panel Assembly	6
Dual Timer “Tap Touch” Controls	7
Phase 7 Non-Coin Microprocessor Control Box Assembly	8
Dual Timer Control Box Assembly	9
37-1/4” Main Door Assembly	10
Front Panel Assembly for Models Mfd. as of January 1, 2002	11
Front Panel Assembly for Models Mfd. prior to January 1, 2002	12
Main Door Switch Assembly	13
Sensor Bracket Assemblies	14
Lint Trap Assembly for Models Mfd. as of January 1, 2002	16
Drop Lint Door Assembly for Models Mfd. as of January 1, 2002	17
Drop Lint Door Assembly for Models Mfd. prior to January 1, 2002	18
Tumbler / Support Assembly	19
Idler Bearing Assembly	20
Tumbler Bearing Assembly	21
Single-Phase (1 ϕ) MP Rear Electric Relay Panel Assembly	22
208-240V 3-Phase (3 ϕ) MP Rear Electric Relay Panel Assembly	23
460-480V MP Rear Electric Relay Panel Assembly	24
208-240V MP Reversing Rear Electric Relay Panel Assembly	25
460-480V MP Reversing Rear Electric Relay Panel Assembly	26
Single-Phase (1 ϕ) Dual Timer Rear Electric Relay Panel Assembly	27
460-480V Dual Timer Rear Electric Relay Panel Assembly	28
208-240V Dual Timer Reversing Rear Electric Relay Panel Assembly	29
Non-Reversing Totally Enclosed, Fan-Cooled Motor Mount Assembly	30
Reversing Totally Enclosed, Fan-Cooled Motor Mount Assembly	32
Direct Spark Ignition Burner Assembly	34
Sail Switch Assembly	36
Fire Suppression System Assembly for Models Mfd. as of November 8, 2011	37
Fire Suppression System Assemblies for Models Mfd. prior to November 8, 2011	38
Back Guard Assemblies	39
Additional Parts Available	40

Phase 7 Non-Coin Microprocessor Control Door Assembly

For Models Mfd. as of July 11, 2002

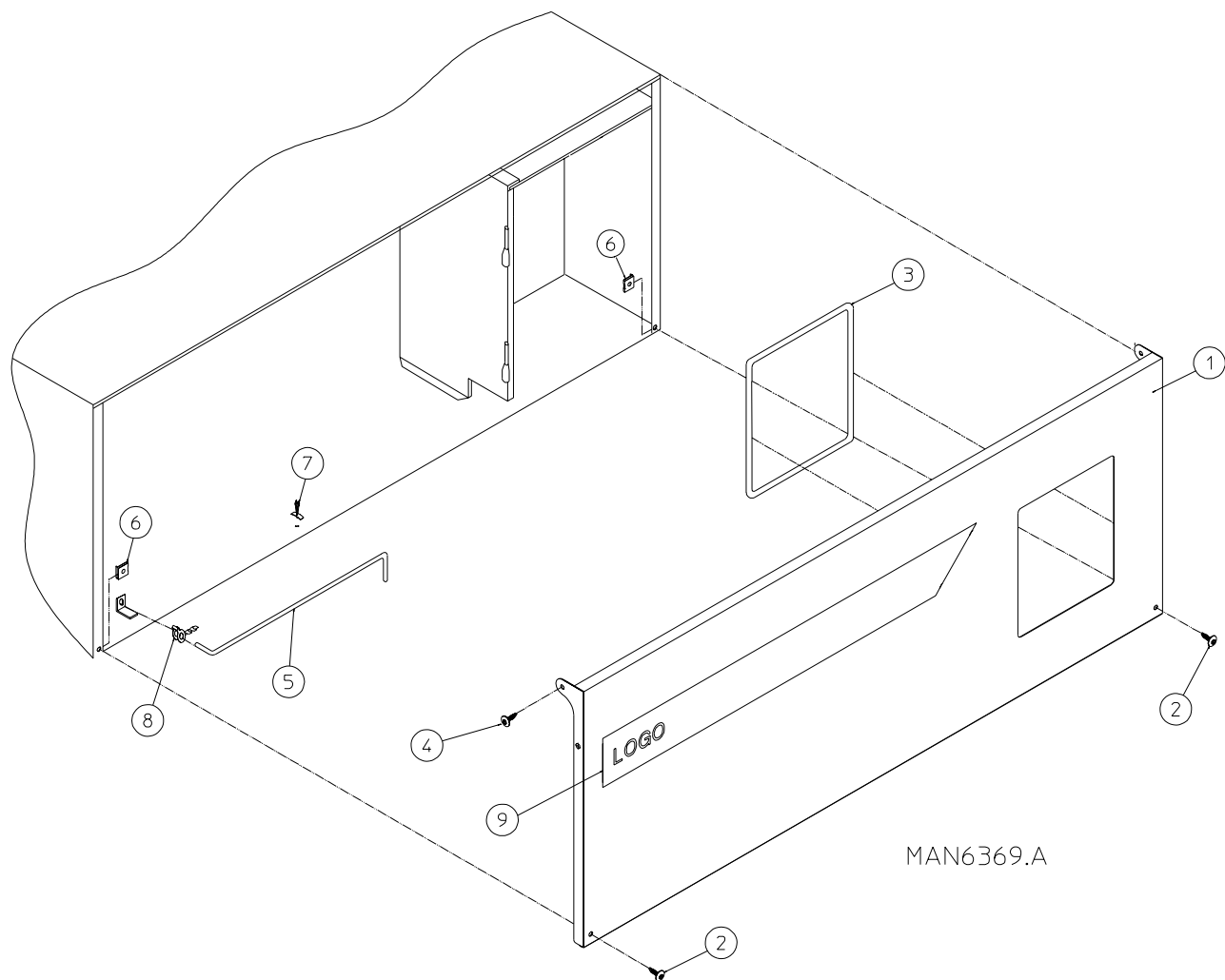

Illus. No.	Part No.	Qty.	Description
1	883474	1	White Non-Coin Control Door (includes illus. nos. 1 and 3)
2	150321	2	#10-32 x 1/2" Phillips Machine Screw
3	117604	4	Noise Suppression Tape (sold by the foot)
4	150317	2	#10-16 x 3/4" TORX® + BTN, Type 1
5	102503	1	Control Door Support Rod
6	154011	2	#10-32 Multi-Thread U-Nut
7	102602	1	Control Door Rod Support Latch
8	102601	1	Control Door Rod Retainer Clip
9	_____*	1	Logo Only

* Contact reseller for logo.

Control Door Assembly

For Models Mfd. prior to July 11, 2002

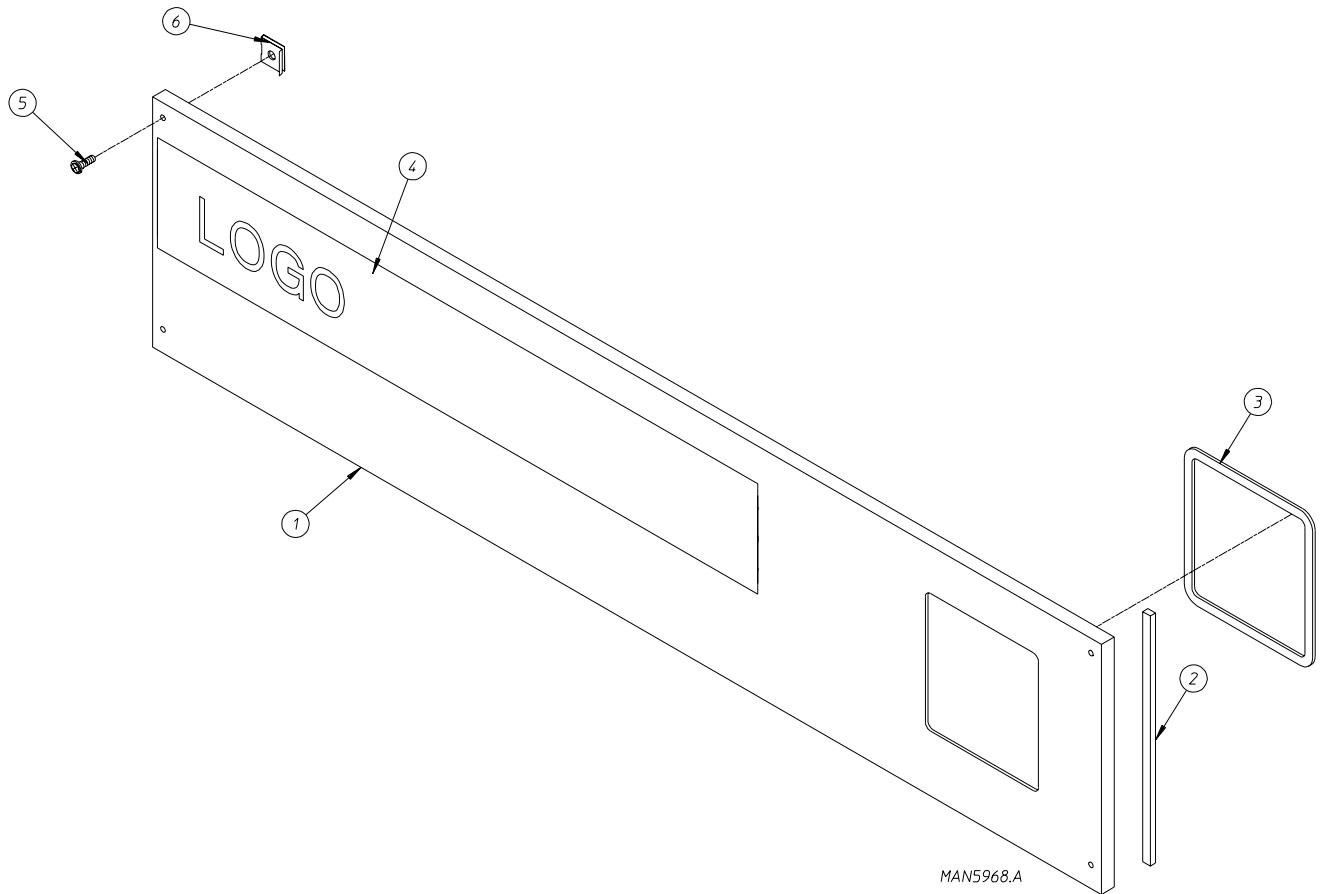

<u>Illus. No.</u>	<u>Part No.</u>	<u>Qty.</u>	<u>Description</u>
1	801823	1	Control Door Assembly (includes illus. nos. 1 through 3)
2	117605	2	Neoprene Sponge Tape
3	117604	4	Noise Suppression Tape (sold by the foot)
4	_____*	1	Logo Only
5	150314	4	#10-32 x 1/2" TORX® Screw
6	154011	4	#10-32 Multi-Thread U-Nut

* Contact reseller for logo.

Phase 7 Non-Coin Microprocessor Control Panel Assembly

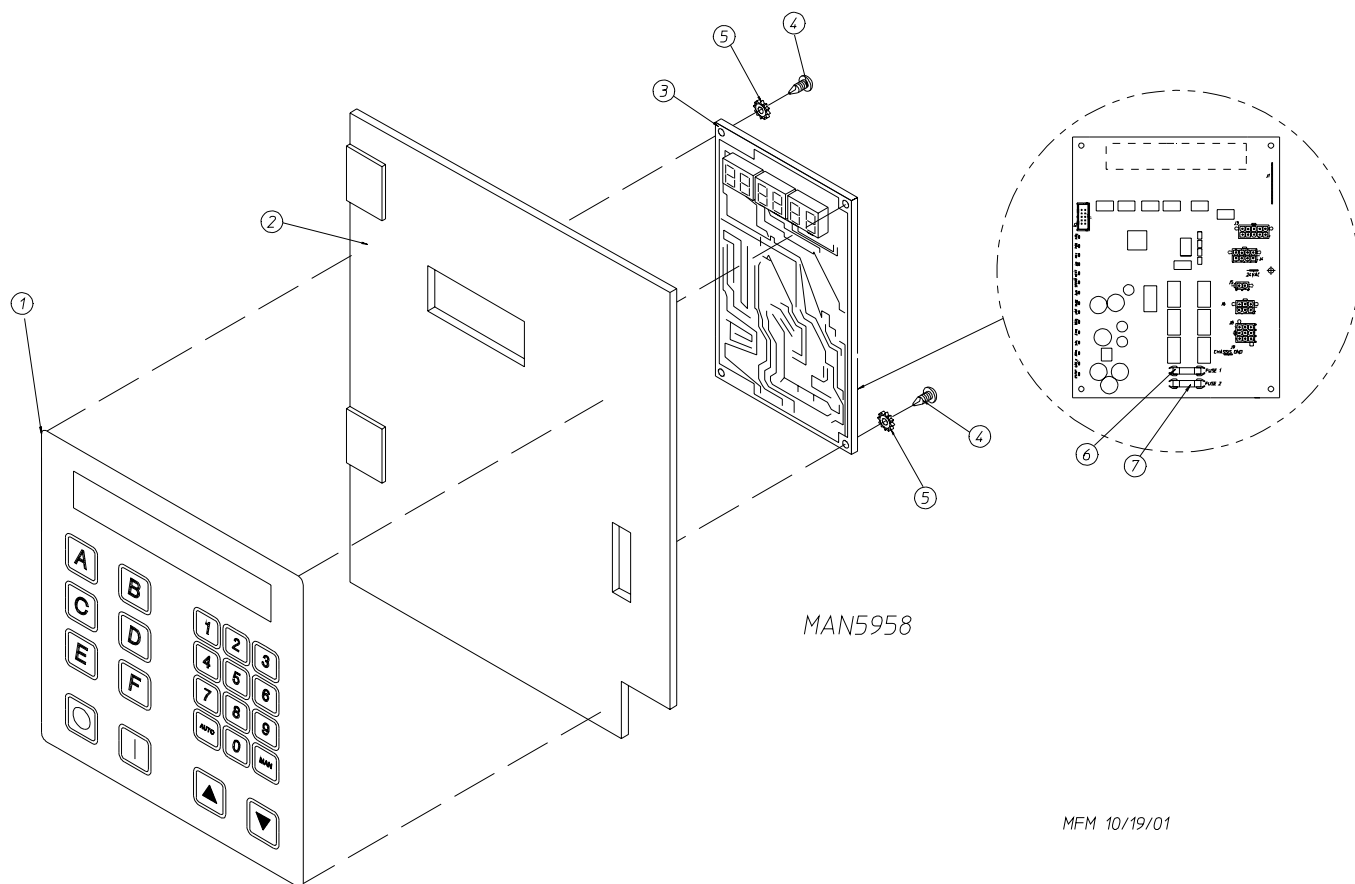

<u>Illus. No.</u>	<u>Part No.</u>	<u>Qty.</u>	<u>Description</u>
1	112577	1	Phase 7 Non-Coin Keypad
2	850984	1	Phase 7 Non-Coin Microprocessor Controller (computer) Panel Only
3	887003	1	Phase 7 Microprocessor Controller with F.S.S. and Pressure Switch
	887000	1	Phase 7 Microprocessor Controller with F.S.S. and without Pressure Switch
	887024	1	Phase 7 Microprocessor Controller (computer) without F.S.S.
4	150005	2	#6-32 x 3/4" Phillips Round Head Machine Screw
5	153010	2	#6 Star Washer
6	136016	1	5-Amp Fuse
7	136097	1	500 mA Fuse

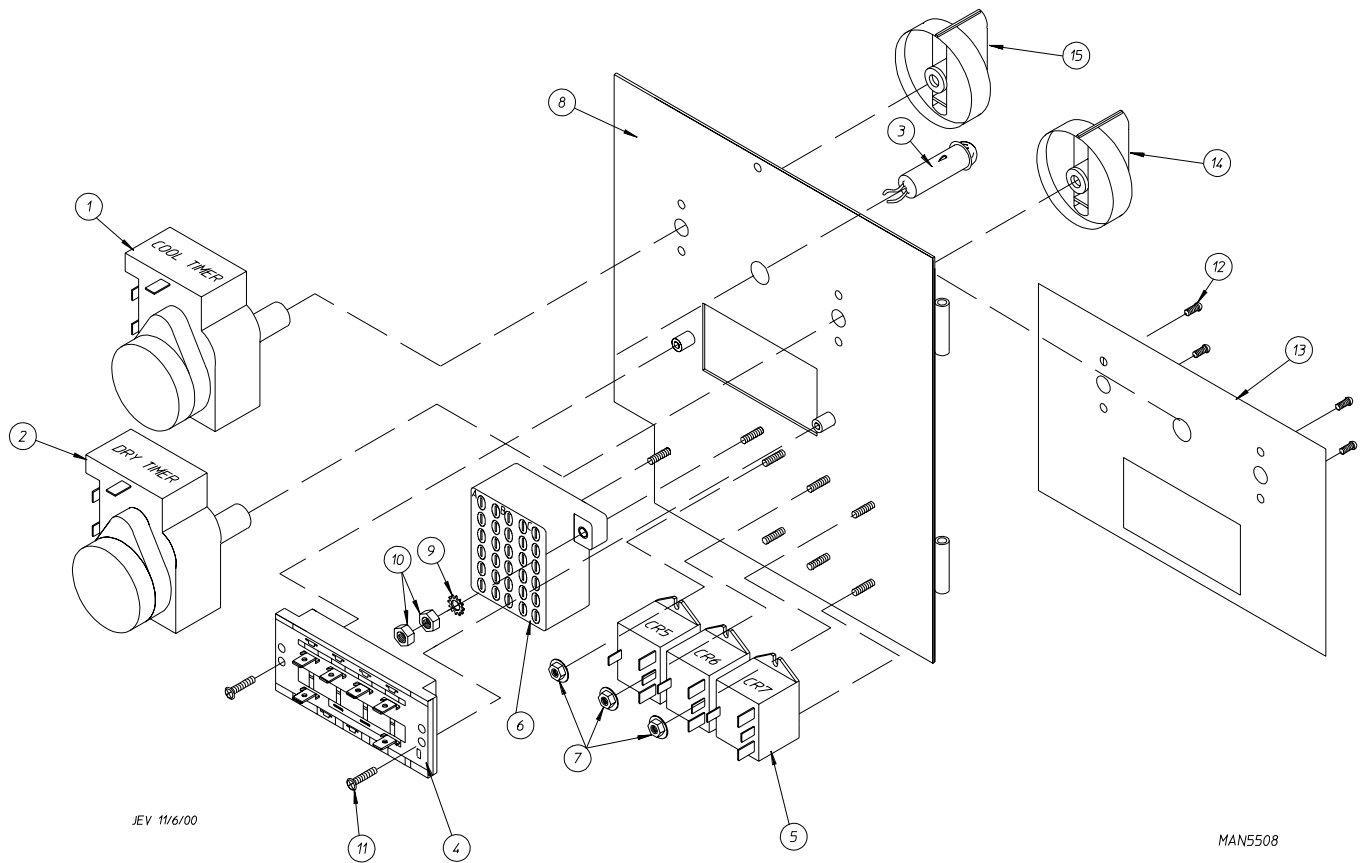

Illus. No.	Part No.	Qty.	Description
1	824298	1	15 Minute Timer – 24 VAC
2	824299	1	60 Minute Timer – 24 VAC
3	824175	1	Red Pilot Light – 24 VAC
4	122301	1	"Tap Touch" Switch
5	131932	3	Relay SPST 24v
6	120730	1	30-Position Terminal Block
7	151000	6	#6-32 Pal Nut
8	882903	1	Dual Timer Panel Complete (includes illus. nos. 1 through 15)
	850392	–	Dual Timer Panel Only
9	153010	2	#6 Star Washer
10	152000	3	#6-32 Hex Nut
11	150207	2	#10-24 x 1/2" Phillips Pan Head Machine Screw
12	150110	4	#8-32 x 1/4" Phillips Round Head Machine Screw
13	112563	1	Dual Timer Panel Overlay
14	124104	1	Pure Touch Knob with Red Pointer
15	124105	1	Pure Touch Knob with Blue Pointer

Phase 7 Non-Coin Microprocessor Control Box Assembly

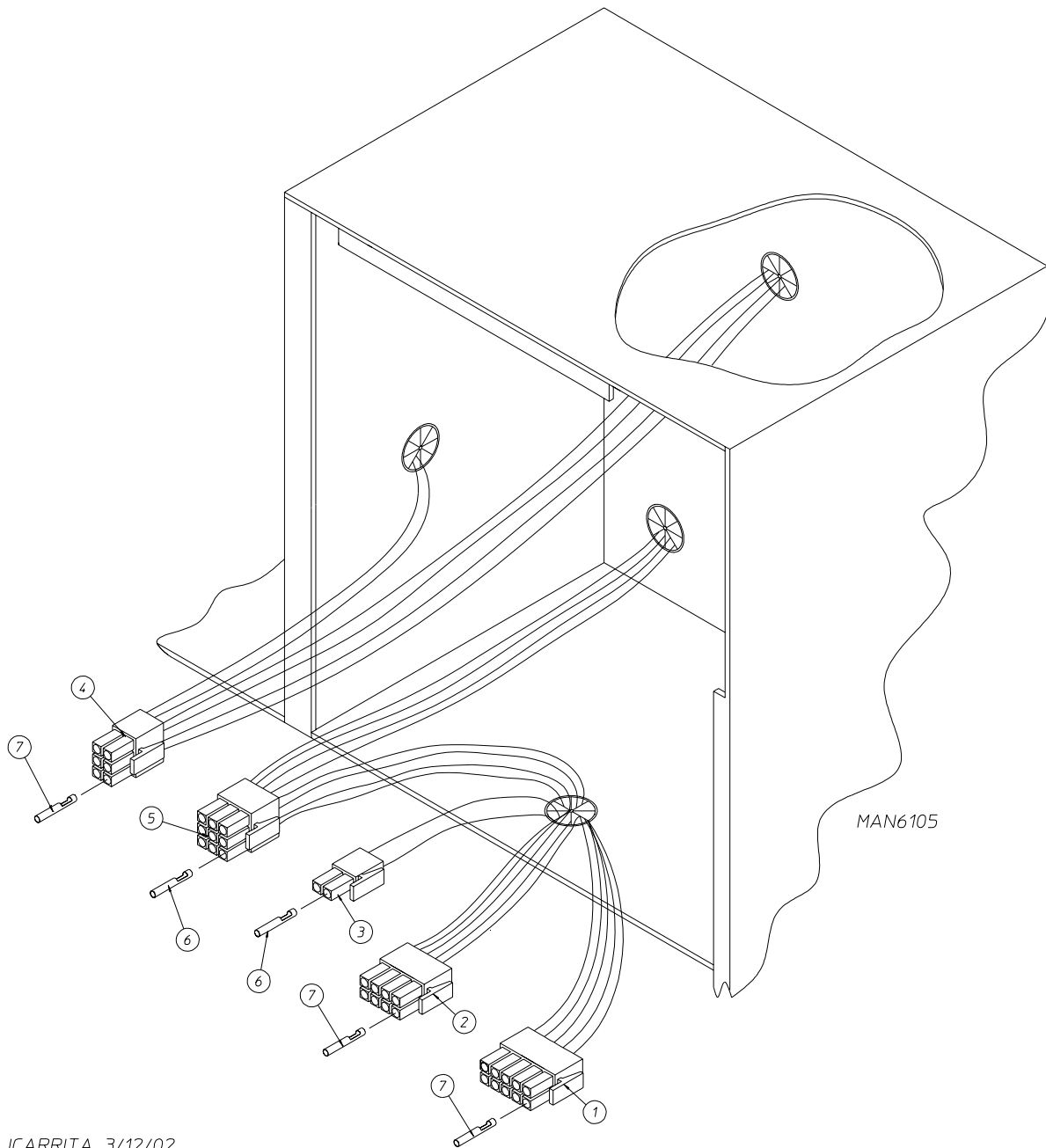

JCARRITA 3/12/02

<u>Illus. No.</u>	<u>Part No.</u>	<u>Qty.</u>	<u>Description</u>
1	122681	1	10-Pin Connector
2	122676	1	8-Pin Connector
3	122646	1	2-Pin Connector
4	122683	1	6-Pin Connector
5	122640	1	9-Pin Connector
6	122706	*	#20-16 U.M.N.L. Socket
7	122669	*	Female Crimp Terminal

* As needed.

Dual Timer Control Box Assembly

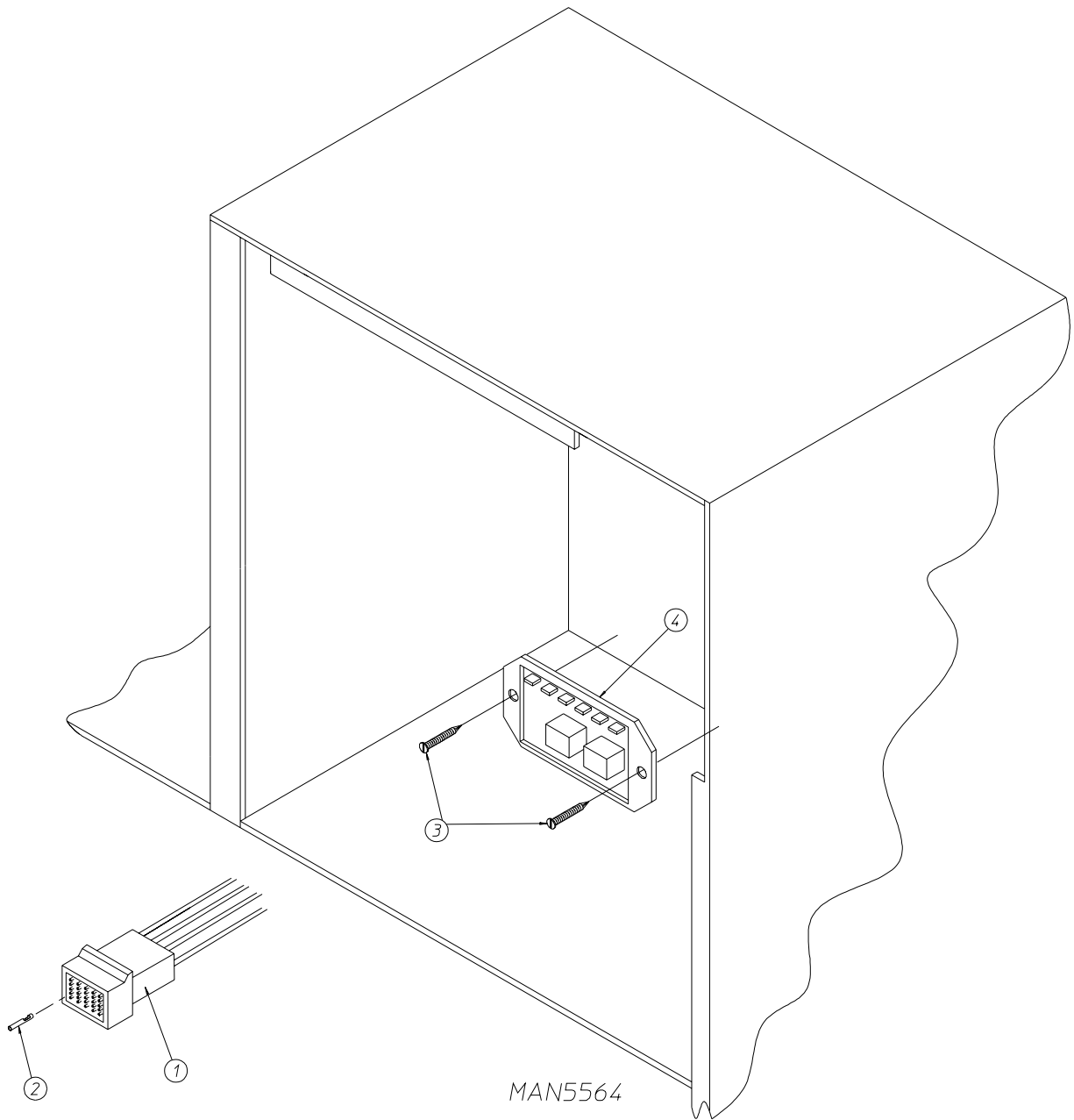

JCARRITA 12/26/00

<u>Illus. No.</u>	<u>Part No.</u>	<u>Qty.</u>	<u>Description</u>
1	122641	1	15-Pin Connector
2	122706	15	Socket Terminal
	122801	1	Pin / Socket Terminal Extraction Tool ... Not Illustrated
3	150301	2	#8-18 x 7/16" Phillips Pan Head TEK Screw
4	132198	1	Reversing Timer 24 Volt (for reversing dual timer models Only)

37-1/4" Main Door Assembly

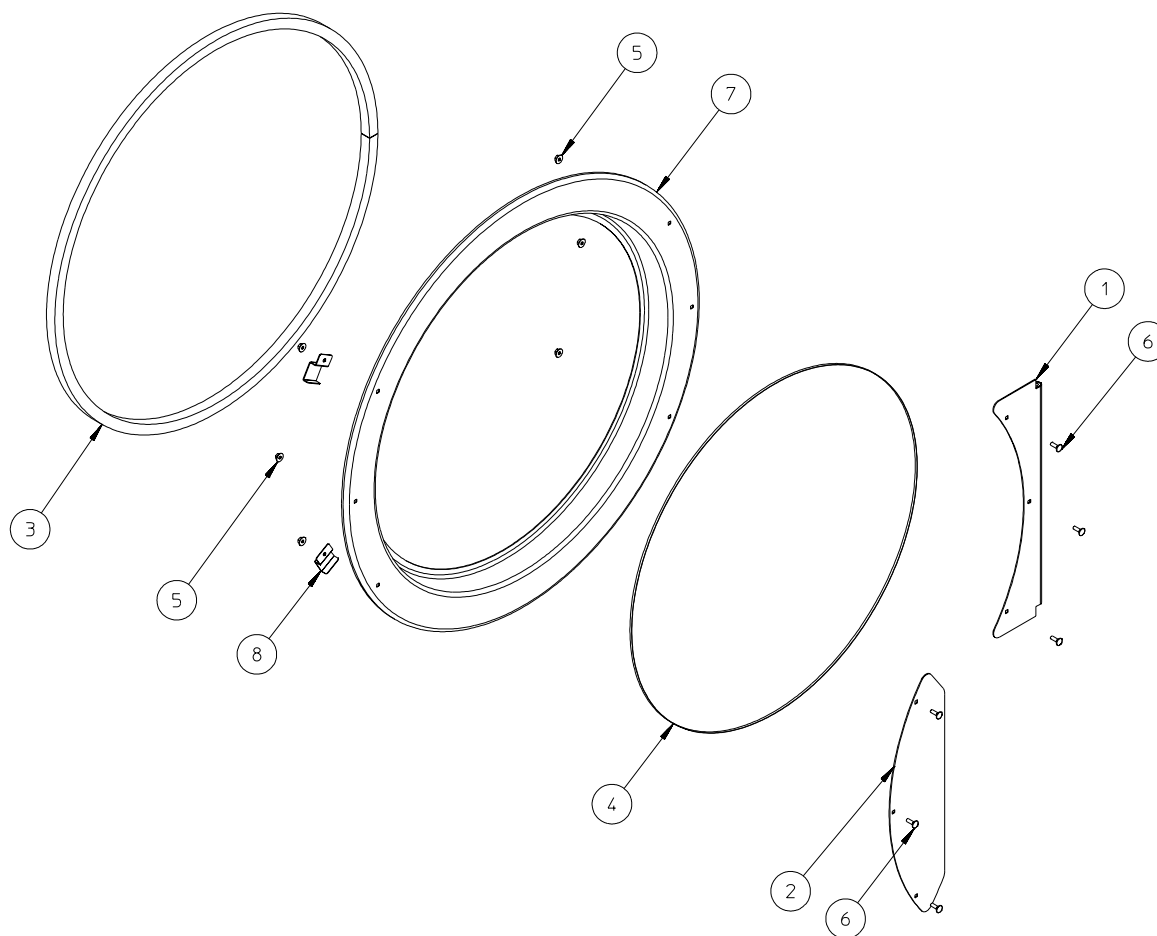

JCARRITA 1/2/08

MAN7532

Illus. No.	Part No.	Qty.	Description
1	835128	1	Main Door Hinge (for models mfd. as of February 18, 2005)
	881685	1	Main Door Hinge (for models mfd. prior to February 18, 2005)
2	314729*	1	Main Door Handle
3	102357	1	Door Gasket
	170731	1	Black Adhesive (10.3 oz. cartridge)
	170730	1	White Adhesive (10.3 oz. cartridge)
4	102221	1	Door Glass
	170731	1	Black Adhesive (10.3 oz. cartridge)
	170730	1	White Adhesive (10.3 oz. cartridge)
5	152014	6	1/4-20 Free Spin Wash Nut
6	150683	6	1/4-20 x 5/8" Carriage Bolt
7	801600	1	Main Door Assembly Complete (for models mfd. as of September 11, 2006)
	835003	1	Main Door Assembly Complete (for models mfd. between February 18, 2005 and September 11, 2006)
	881689	1	Main Door Assembly Complete (for models mfd. prior to February 18, 2005)
8	185522	2	Main Door Magnet Bracket (for models mfd. as of September 11, 2006)

* Specify color when ordering.

Front Panel Assembly

For Models Mfd. as of January 1, 2002

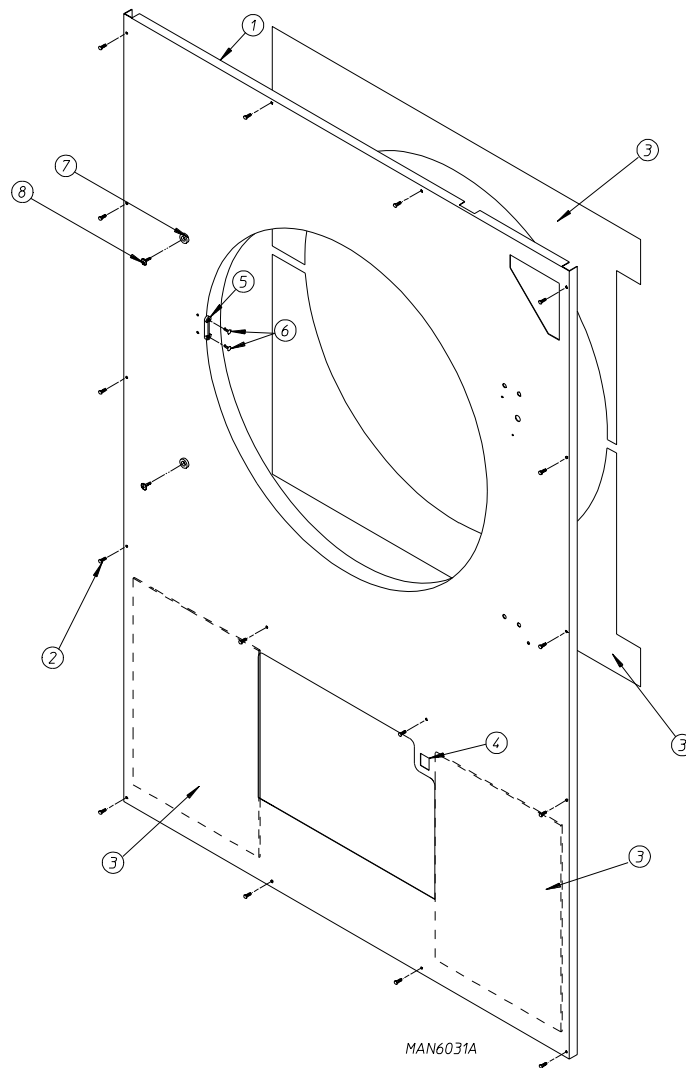

Illus. No.	Part No.	Qty.	Description
1	801606	1	Right-Hand Front Panel Assembly (for non-coin models) with Magnets
	801608	1	Right-Hand Front Panel Assembly (for coin models) with Magnets
	801574*	1	Right-Hand Front Panel Assembly (for non-coin models) with Magnets and E-Stop
	883246*	1	Right-Hand Front Panel Assembly (for non-coin models) with Friction Catch (includes illus. nos. 1, 3, 5, and 6)
2	150313	14	#10-16 x 1/2" TORX® + BTN, Type 1
	150318	**	25 IP Stick-Fit TORX® + Bit ... Not Illustrated
3	116147	2	13" x 18-1/2" Rear Lower Wall Insulation
	116320	1	Top Front Panel Insulation
	116321	1	Bottom Front Panel Insulation
4	122002	1	Lint Drawer Switch
5	881987	1	Friction Door Latch Kit (includes illus. nos. 5 and 6)
6	154215	2	5/32" Pop Rivet
7	102004	2	0.750 Round Door Magnet
8	152223	2	1/2" Torx® Head Screw

* Specify color when ordering.

** As needed.

Front Panel Assembly

For Models Mfd. prior to January 1, 2002

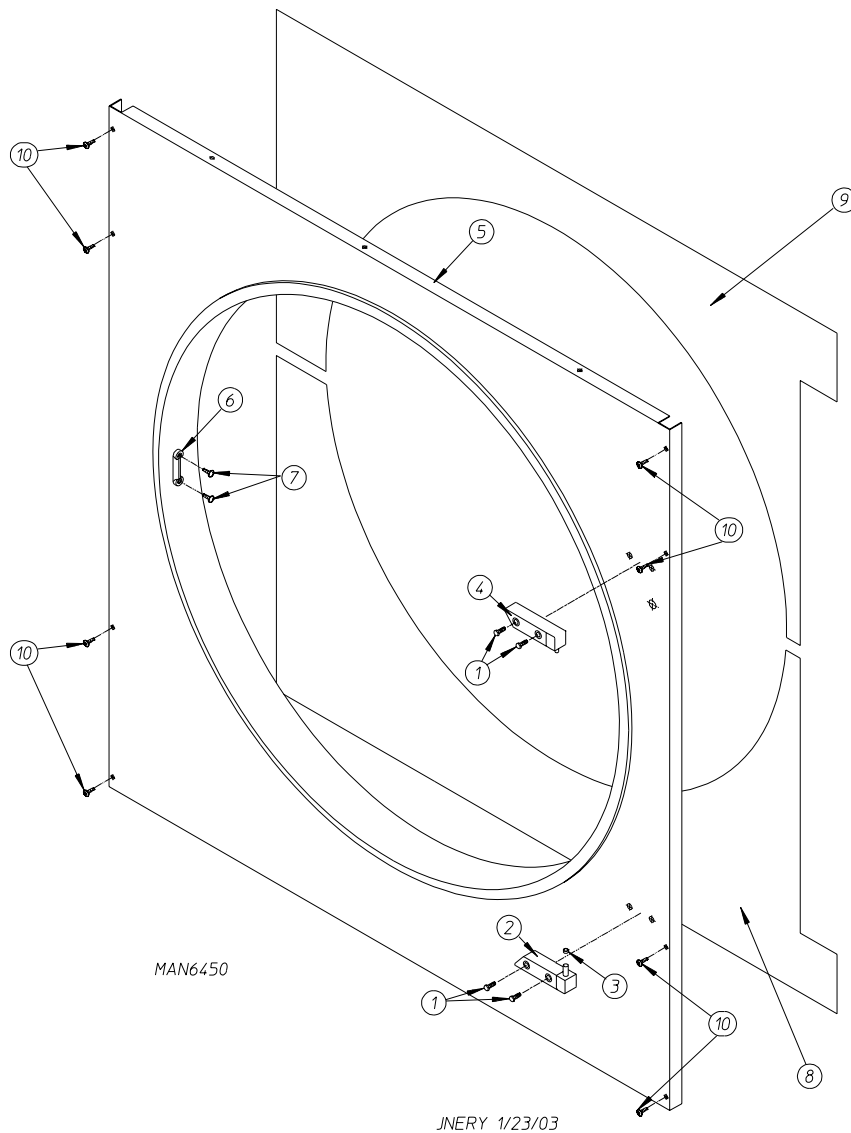

Illus. No.	Part No.	Qty.	Description
1	150445	4	1/4-20 x 3/4" Stainless Steel Cap Screw
2	881441*	1	White Bottom Hinge Block (includes illus. nos. 1 through 3)
3	153031	1	Nylon Washer
4	881440*	1	White Top Hinge Block with Cap Screws (includes illus. nos. 1 and 4)
5	882057*	1	White Front Panel Assembly (includes illus. nos. 5 through 7)
6	170330	1	Friction Door Catch
7	154215	2	5/32" Pop Rivet
8	116321	1	Bottom Front Panel Insulation
9	116320	1	Top Front Panel Insulation
10	150313	8	#10-16 x 1/2" TORX® + BTN, Type 1
	150318	**	25 IP Stick-Fit TORX® + Bit ... Not Illustrated

* Specify color if other than white.

** As required.

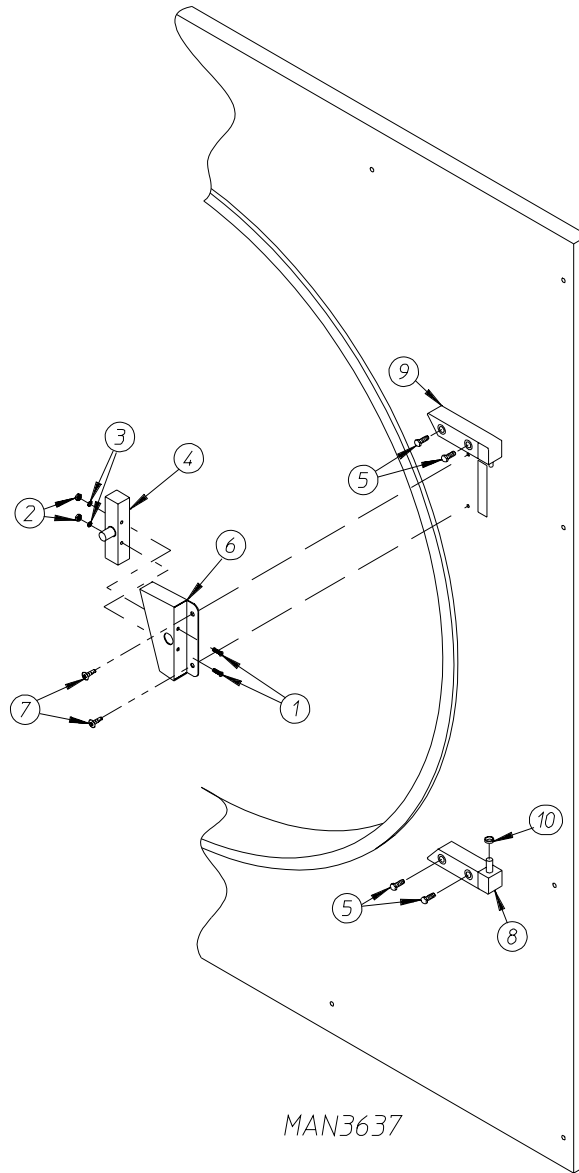

Illus. No.	Part No.	Qty.	Description
1	150006	2	#6-32 x 7/8" Phillips Pan Head Machine Screw
2	152013	2	#6-32 Hex Nut
3	153010	2	#6 Star Washer
4	137005	1	Single-Pole Door Switch
5	150445	4	1/4-20 x 3/4" Cap Screw
6	882866*	1	Black Main Door Switch Housing Only
	881153*	1	Black Main Door Housing Assembly (includes illus. nos. 1 through 4 and 6)
7	150301	2	#8-18 x 7/16" Phillips Pan Head TEK Screw
8	881441*	1	White Bottom Hinge Block with Cap Screws (includes illus. nos. 5, 8, and 10)
9	881440*	1	White Top Hinge Block with Cap Screws (includes illus. nos. 5 and 9)
10	153031	1	Nylon Washer

* Specify color if other than white.

Sensor Bracket Assemblies

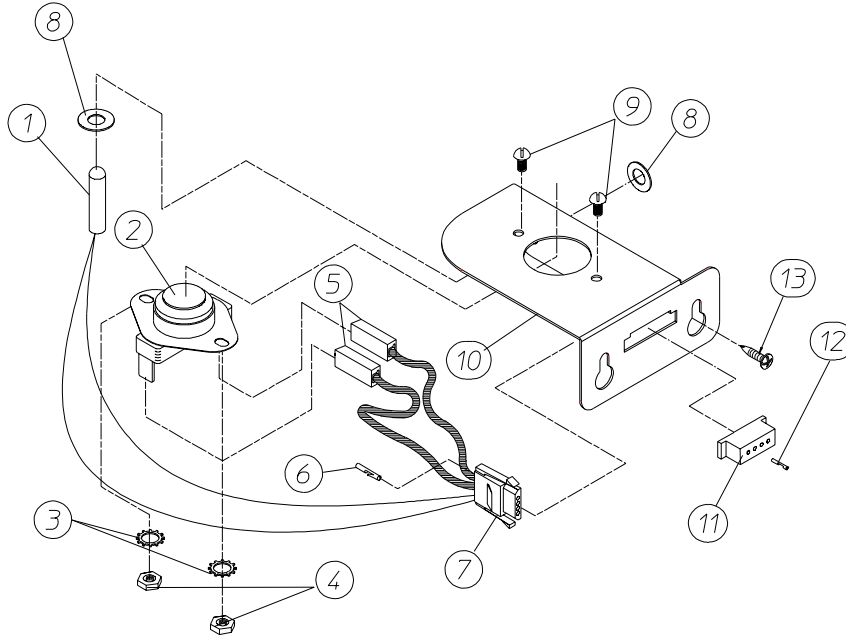

MICROPROCESSOR SENSOR BRACKET ASSEMBLY

MAN6453

JNERY 1/23/03

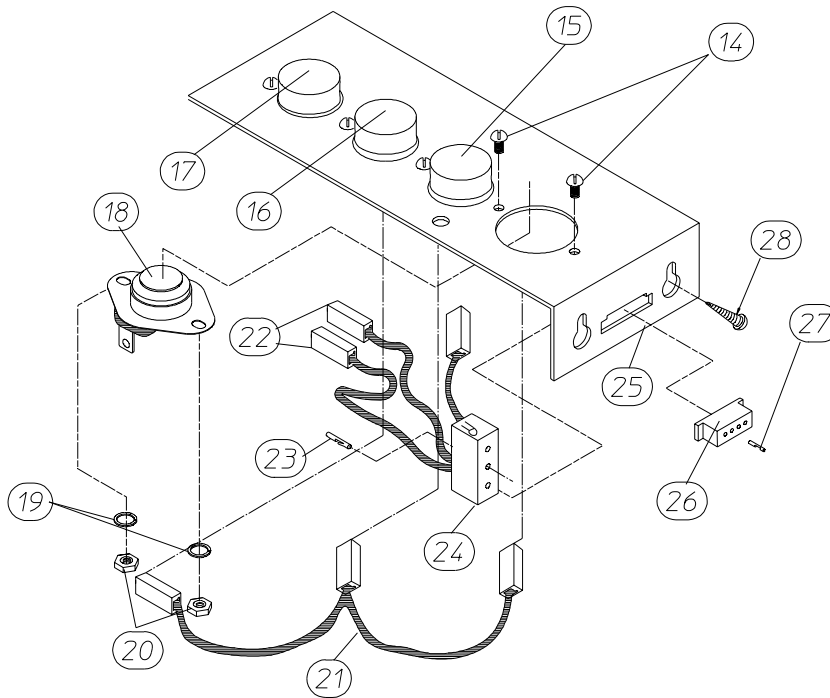

NON-COMPUTER SENSOR BRACKET ASSEMBLY

<u>Illus. No.</u>	<u>Part No.</u>	<u>Qty.</u>	<u>Description</u>
1	880251	1	1/4" Temperature Sensor Probe Assembly (includes illus. nos. 1 and 5 through 8)
2	130103	1	225° Automatic Reset Thermostat
3	153010	2	#6 Star Washer
4	152000	2	#6-32 Hex Nut
5	121028	2	Insulated Female Terminal
6	122701	4	Socket Terminal Only
	122801	1	Pin / Socket Extraction Tool ... Not Illustrated
7	122605	1	4-Pin Connector (female)
8	154007	2	1/4" Tinnerman Push-On Fastener
9	150005	2	#6-32 x 1/4" Phillips Round Head Machine Screw
10	824051	1	Microprocessor Sensor Bracket Assembly Complete (includes illus. nos. 1 through 10)
	322214	1	Microprocessor Sensor Bracket Only
11	122604	1	4-Pin Connector (male)
12	122700	4	Pin Terminal Only
13	150301	2	#8-18 x 7/16" Phillips Pan Head TEK Screw
14	150005	5	#6-32 x 1/4" Phillips Round Head Machine Screw
15	130111	1	130° Large Thermostat
16	130100	1	150° Large Thermostat
17	130103	1	225° Automatic Reset Thermostat
18	130101	1	180° Large Thermostat
19	153010	5	#6 Star Washer
20	152000	5	#6-32 Hex Nut
21	882535	1	Sensor Jumper Only
22	121028	4	Insulated Female Terminal
23	122701	4	Socket Terminal Only
24	122605	1	4-Pin Connector (female)
	882534	1	Sensor Bracket Harness Assembly (includes illus. nos. 22 through 24)
25	882536	1	Non-computer Sensor Bracket Assembly Complete – Includes Thermostats (includes illus. nos. 14 through 25)
	322062	1	Universal Sensor Bracket Only
26	122604		4-Pin Connector (male)
27	122700	4	Pin Terminal Only
	122801	1	Pin / Socket Extraction Tool ... Not Illustrated
28	150301	2	#8-18 x 7/16" Phillips Pan Head TEK Screw

Lint Trap Assembly

For Models Mfd. as of January 1, 2002

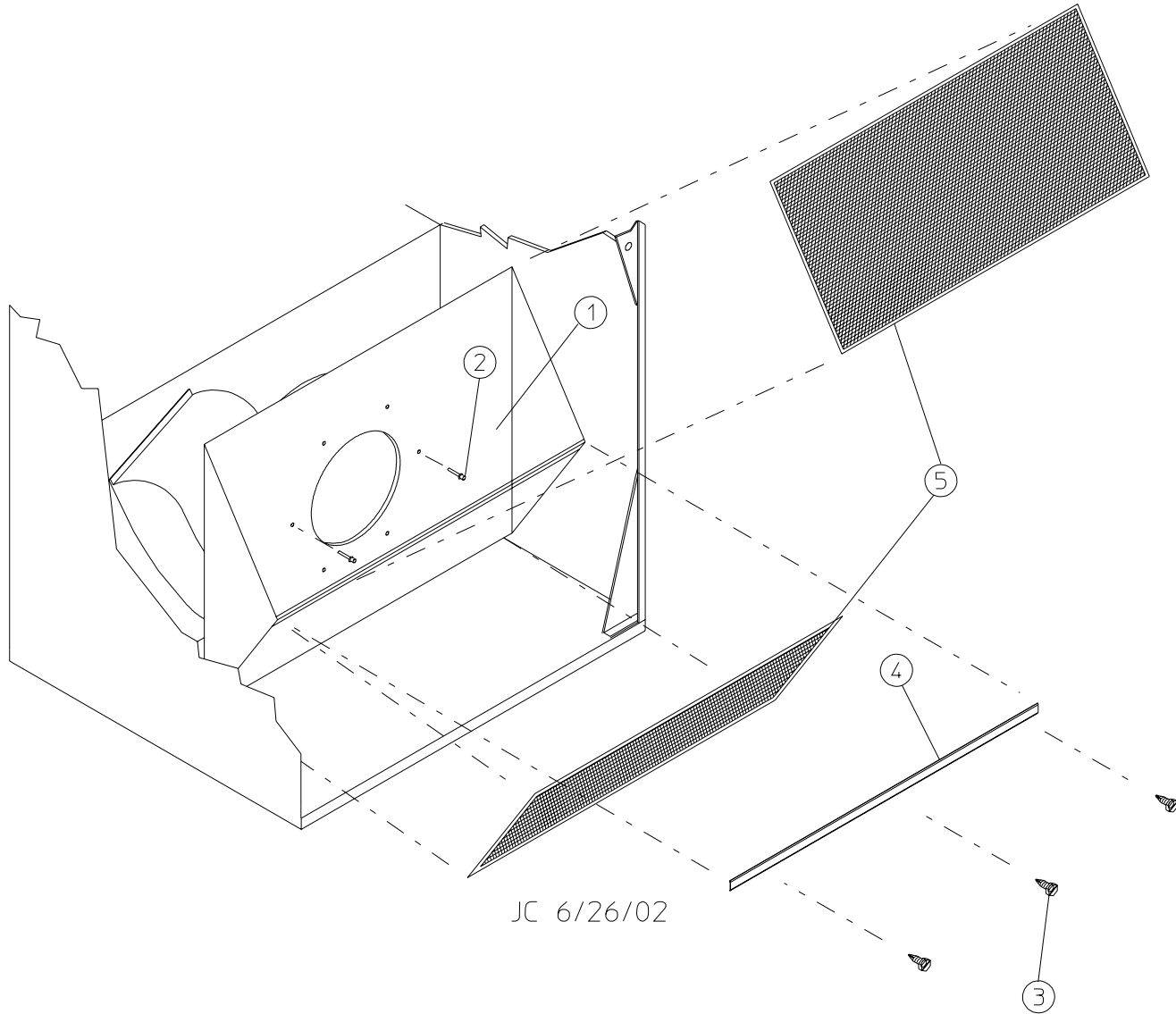

MAN6192

<u>Illus. No.</u>	<u>Part No.</u>	<u>Qty.</u>	<u>Description</u>
1	802833	1	Lint Trap Assembly Complete (includes illus. nos. 1 and 3 through 5)
	802834	1	Lint Trap Only
2	154200	6	5/32" Pop Rivet
3	150300	3	#10-16 x 1/2" Hex Washer TEK Screw
4	304100	1	Lint Screen Holder Only
5	800500	2	Lint Screen Assembly

Drop Lint Door Assembly

For Models Mfd. as of January 1, 2002

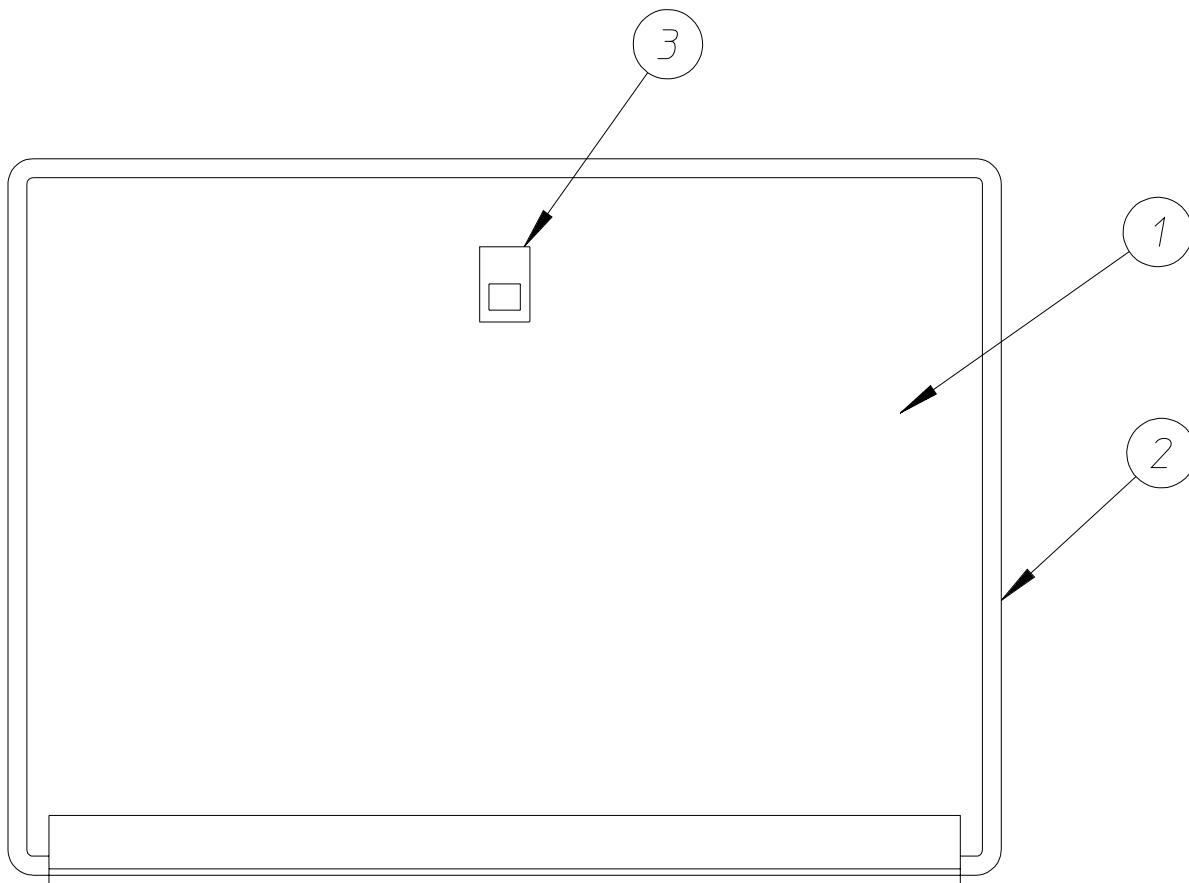

ST 12/11/01

MAN6030

Illus. No.	Part No.	Qty.	Description
1	802277	1	Drop Lint Door Assembly with Latch (includes illus. nos. 1 through 3)
	802265*	1	Drop Lint Door Assembly with Lock (includes illus. nos. 1 through 3)
2	117604	5	Noise Suppression Tape (sold by the foot)
3	170226	1	Slide Latch

* Specify color if other than white.

Drop Lint Door Assembly

For Models Mfd. prior to January 1, 2002

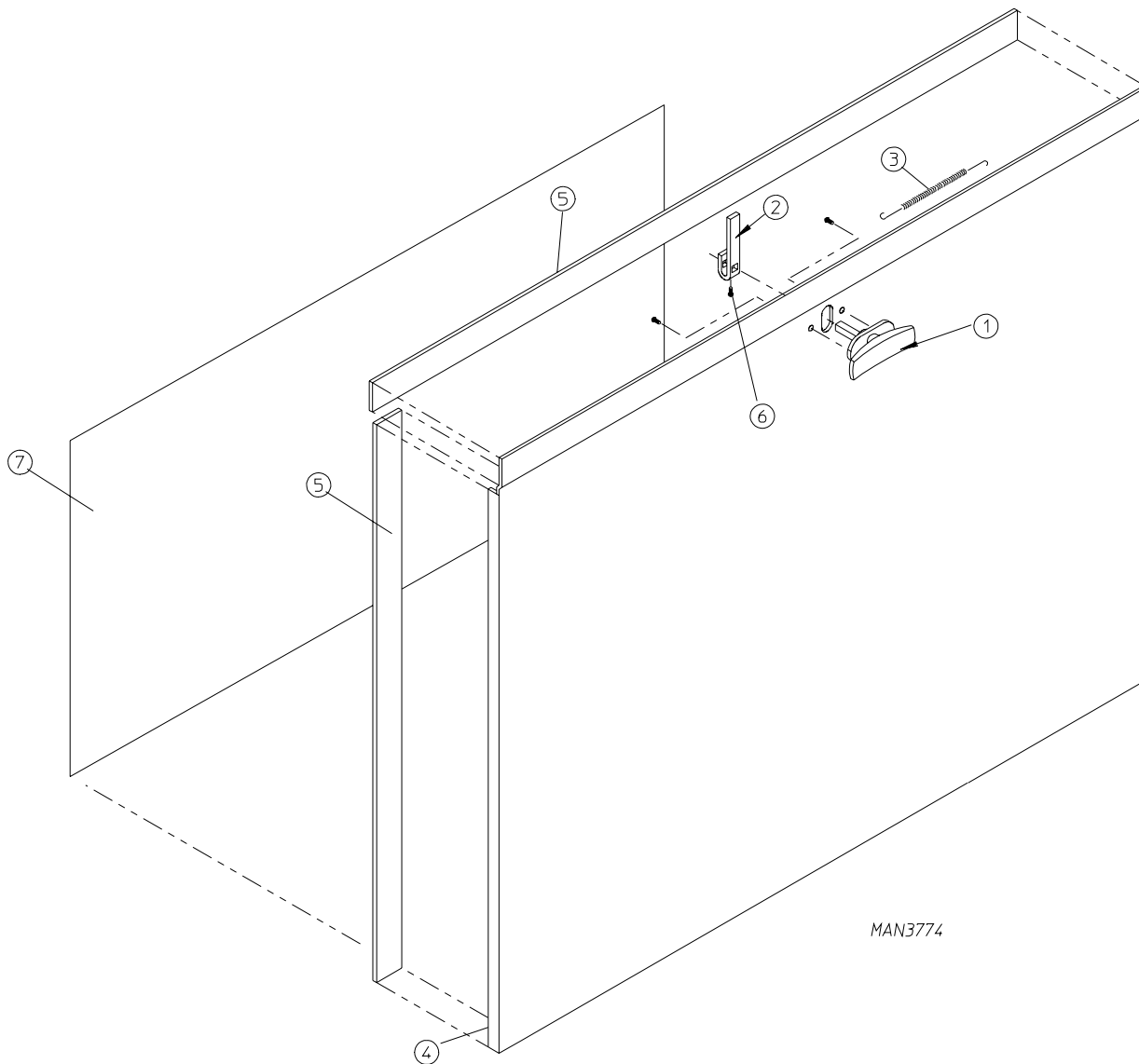

<u>Illus. No.</u>	<u>Part No.</u>	<u>Qty.</u>	<u>Description</u>
1	800150	1	Knob Latch Kit Assembly (includes illus. nos. 1 and 2)
2	160009	1	Knob Latch Adjustable Cam Only
3	157000	1	Drop Lint Door Spring
4	881906*	1	White Insulated Drop Lint Door Assembly (includes illus. nos. 4, 5, and 7)
5	117604	7	Noise Suppression Tape (sold by the foot)
6	150425	1	#12-24 x 3/8" Round Head Machine Screw Only (screw for knob latch adjustable cam)
7	116322	1	Lint Door Insulation

* Specify color if other than white.

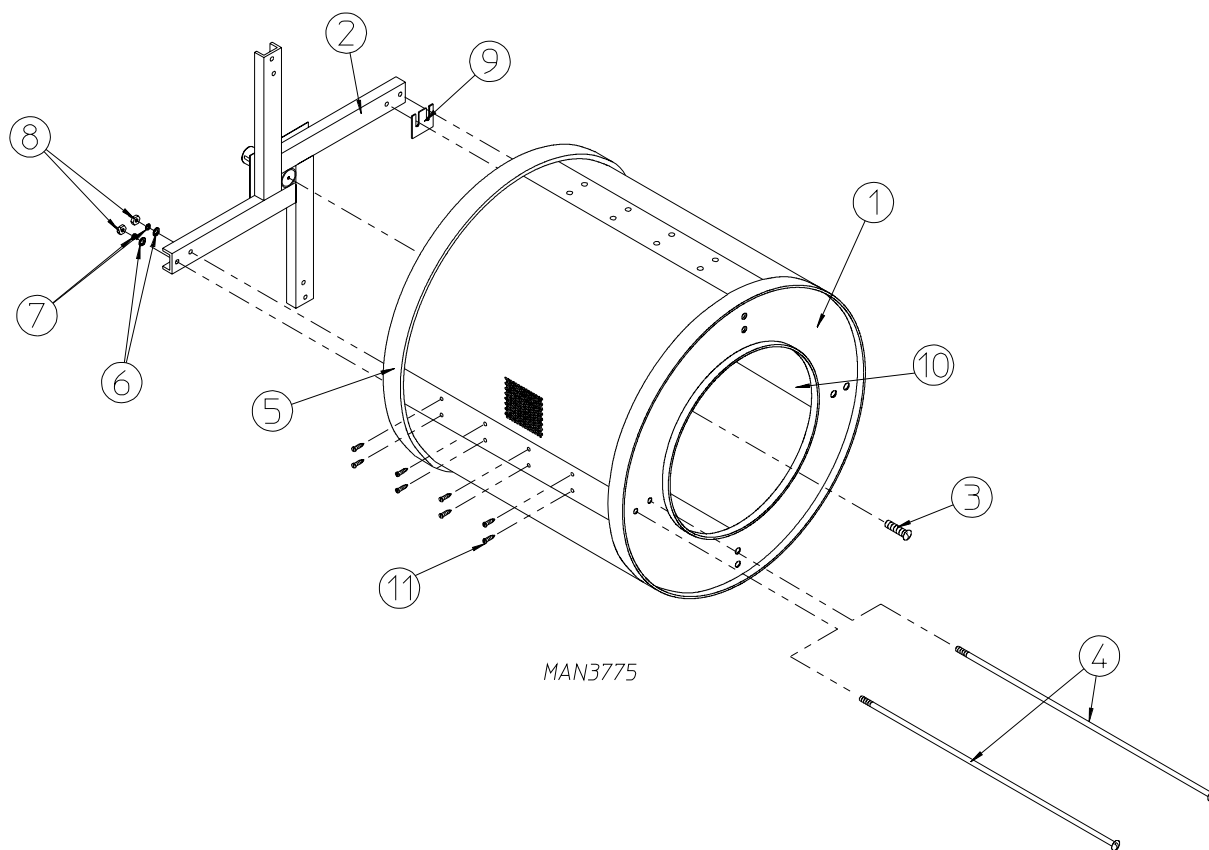

Illus. No.	Part No.	Qty.	Description
1	883523	1	Tumbler Only with Felt Collar
	801773	1	Tumbler and Support Assembly Complete (includes illus. nos. 1 through 11)
2	801774	1	Tumbler Support Only
3	150500	1	5/16-18 x 3/4" Socket Button Head Screw (for models mfd. prior to April 25, 2002)
4	100912	8	1/2-13 x 25-3/8" Tie Rod
5	116006	1	Felt Collar
	170730	1	Felt Collar Adhesive (10.3 oz. cartridge) ... Not Illustrated
6	153028	8	1/2" Flat Washer
7	153026	8	1/2" Lock Washer
8	152011	8	1/2-13 Hex Nut
9	301701	*	Tumbler Shim
10	314701	4	Tumbler Rib
11	150313	32	#10-16 x 1/2" TORX® Crimpite Screw

* As required.

Idler Bearing Assembly

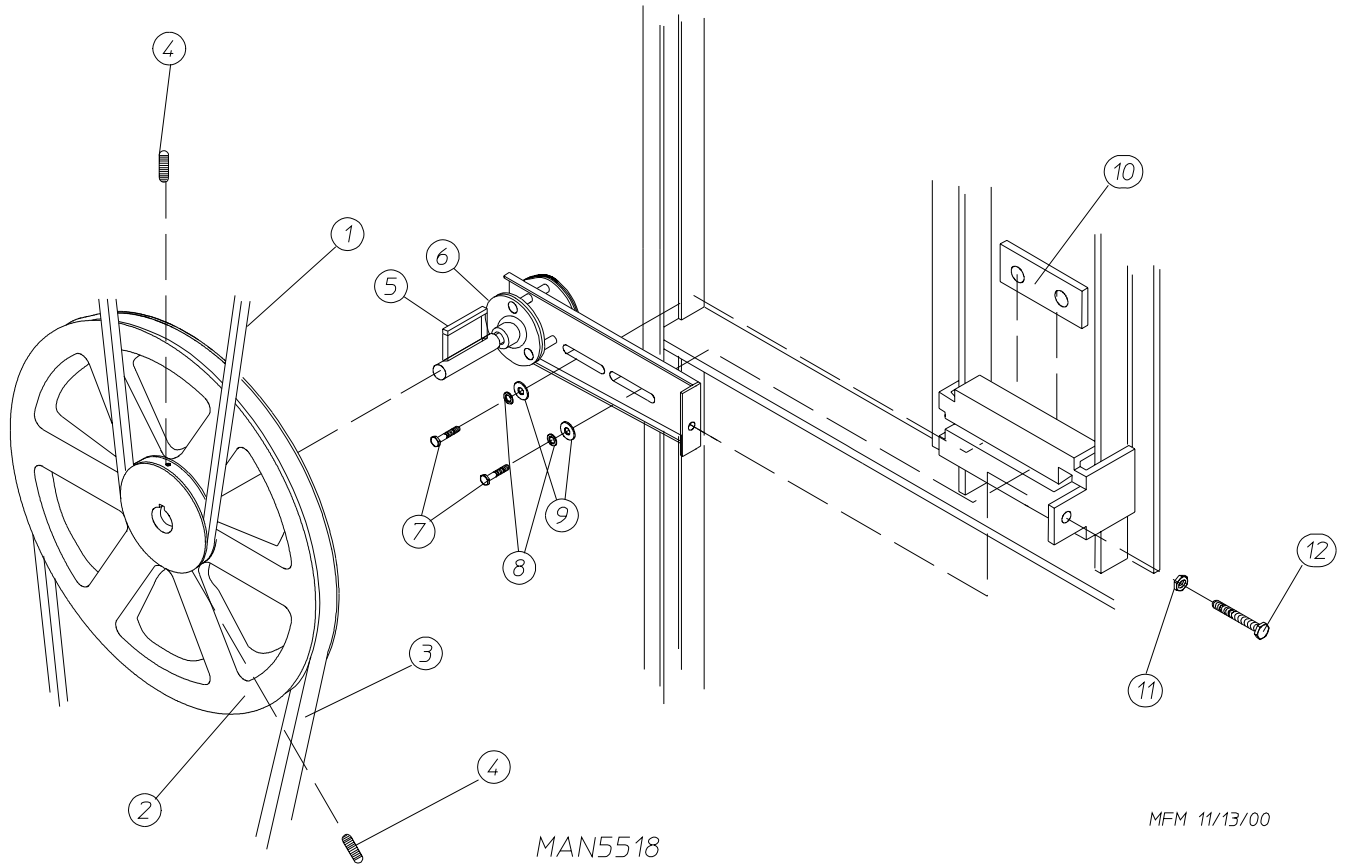

Illus. No.	Part No.	Qty.	Description
1	100185	1	5L-780 V-Belt
2	101140	1	14" x 3" Compound Pulley
3	100178	1	4L-570 V-Belt (idler to motor) for Non-Reversing models Only
	100112	1	4L-610 V-Belt (idler to motor) for Reversing models Only
4	154301	2	5/16-18 x 1" Allen Setscrew
5	100705	1	3/16" x 3/16" x 1-3/8" Key
6	883473	1	Idler Bearing Assembly Complete
7	150617	2	3/8-16 x 1" Hex Head Machine Bolt
8	153005	2	3/8" Lock Washer
9	153004	2	3/8" Flat Washer
10	801009	1	Idler Square Washer
11	152005	1	3/8-16 Hex Nut
12	150623	1	3/8-16 x 5" Hex Head Machine Bolt

Tumbler Bearing Assembly

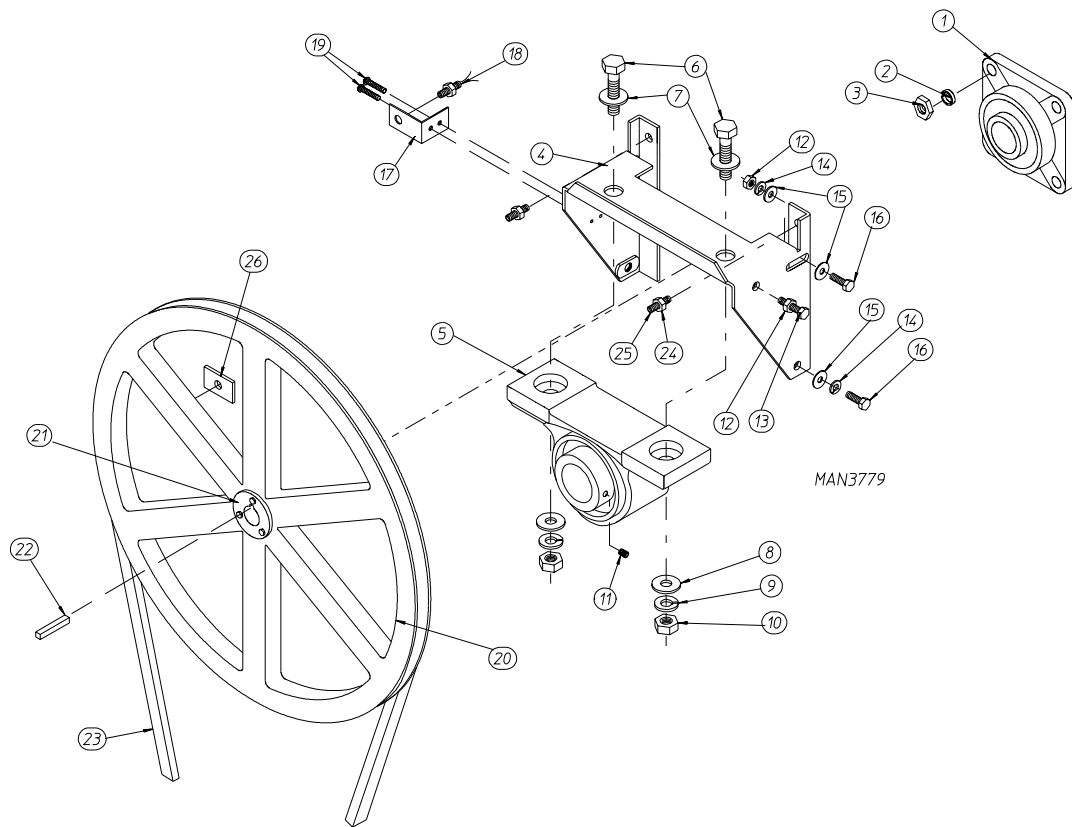

Illus. No.	Part No.	Qty.	Description
1	887195	1	1-15/16" Flange Bearing
2	153025	4	Lock Washer
3	152050	4	Hex Nut
4	801775	1	Pillow Block Bearing Assembly Complete (includes illus. nos. 4 through 13)
	801761	1	Pillow Block Bearing Housing Only
5	887174	1	1-15/16" Pillow Block Bearing
6	150633	2	1/2-13 x 2-1/4" Hex Head Bolt
7	153011	2	9/16" Flat Washer
8	153011	2	9/16" Flat Washer
9	153026	2	1/2" Lock Washer
10	152011	2	1/2-13 Hex Nut
11	154322	2	3/8-24 x 7/16" Setscrew
12	152004	2	5/16-18 Hex Nut
13	150621	2	5/16-18 x 1-1/2" Allen Setscrew
14	153002	4	5/16" Lock Washer
15	153001	6	5/16" Flat Washer
16	150621	4	5/16-18 x 3/4" Hex Bolt
17	314746	1	Rotational Sensor Bracket
18	883386	1	Rotational Sensor Assembly
19	150313	2	#10-16 x 1/2" TORX® + BTN, Type 1
20	882111	1	18" Pulley with Rotational Sensor Magnet
21	101220	1	1-15/16" Taper Lock Bushing
22	100719	1	1/2" x 1/2" x 1-3/8" Key
23	100185	1	5L-780 V-Belt
24	152004	2	5/16-18 Hex Nut
25	150610	2	5/16-18 x 1-1/2" Allen Setscrew
26	102102	1	Rotational Sensor Magnet
	401010	1	Adhesive for Magnet ... Not Illustrated

Single-Phase (1 ϕ) MP Rear Electric Relay Panel Assembly

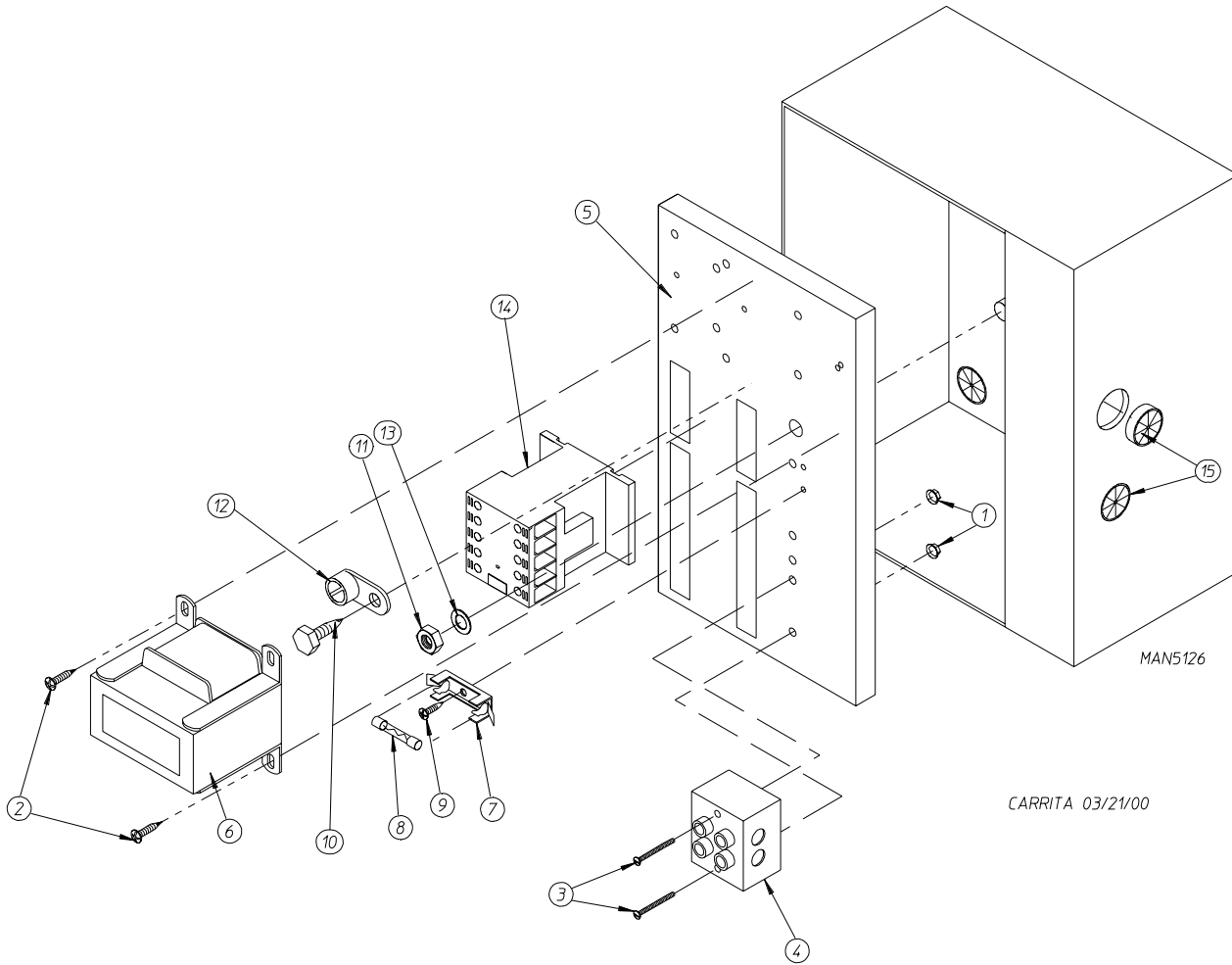

Illus. No.	Part No.	Qty.	Description
1	151000	2	#6-32 Pal Nut
2	150300	2	#10-16 x 1/2" Hex Washer TEK Screw
3	150008	2	#6-32 x 1-1/4" Phillips Pan Head Machine Screw
4	120716	1	2-Position Terminal Block
5	322812	1	Rear Electric Mounting Plate Only
	830468	1	Rear Electric Panel Assembly Complete – 115 Volt (1 ϕ) (includes illus. nos. 1 through 14)
	830469	1	Rear Electric Panel Assembly Complete – 208-240 Volt (1 ϕ) (includes illus. nos. 1 through 14)
6	132070	1	Transformer 120/208/240-24 Volt
7	136008	*	Fuse Holder
8	136049	1	3/4-Amp (Slo-Blo) Fuse (for 120 volt)
	136057	2	1/2-Amp (Slo-Blo) Fuse (for 208-240 volt)
9	150301	2	#8-18 x 7/16" Phillips Pan Head TEK Screw
10	150297	1	#10 x 1/2" Green Hex Washer TEK Screw
11	152004	1	5/16-18 Hex Nut
12	121010	1	L-70 Ground Lug
13	153002	1	5/16" Lock Washer
14	132498	1	2-Pole Contactor
	131396	1	3-Pole Contactor (for 120 volt)
	131395	1	3-Pole Contactor (for 208-240 volt)
15	121300	3	Open / Closed Bushing

* Quantity is 1 for 115v and 2 for 208-240v.

208-240V 3-Phase (3 ϕ) MP Rear Electric Relay Panel Assembly

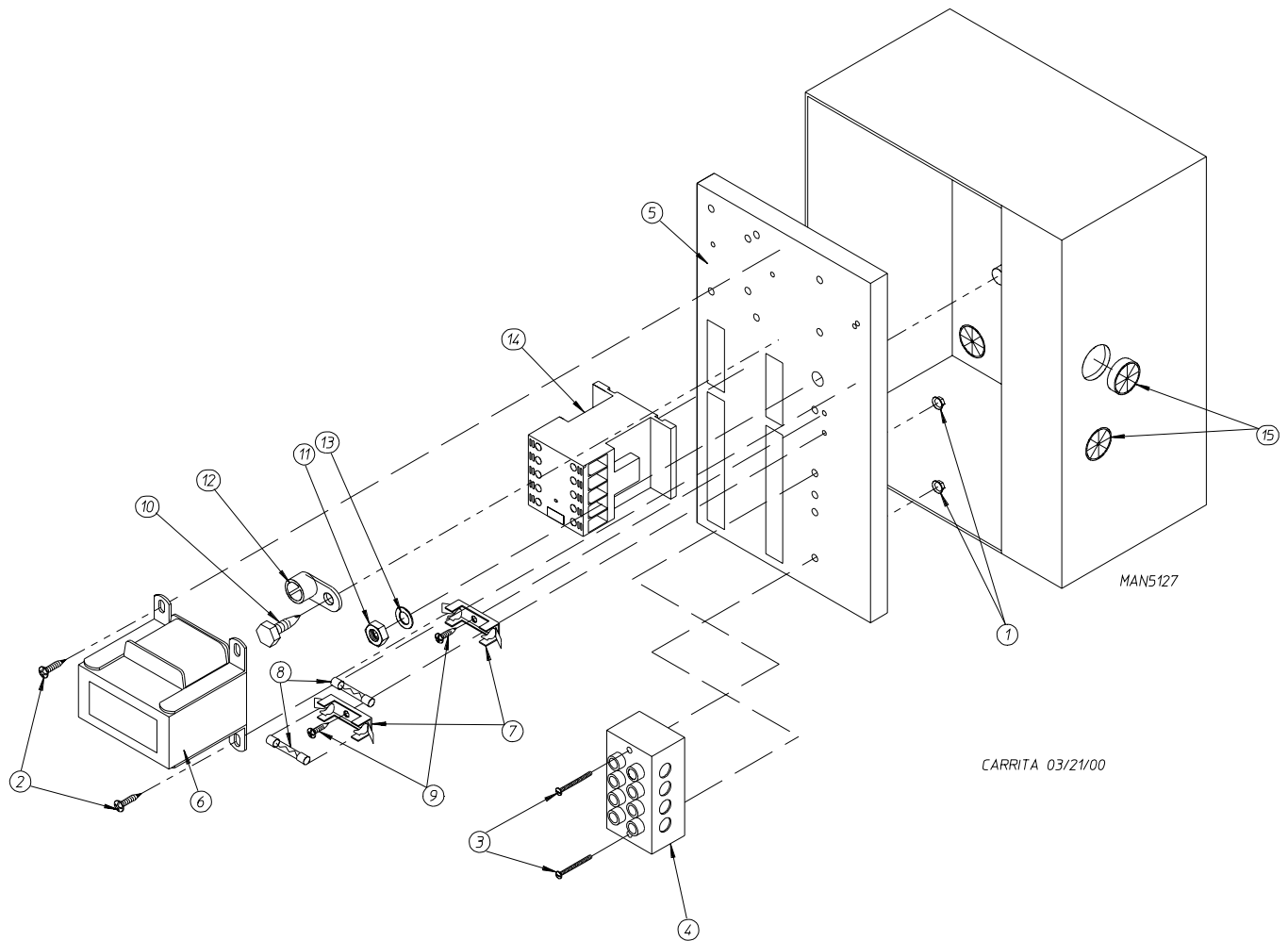

Illus. No.	Part No.	Qty.	Description
1	151000	2	#6-32 Pal Nut
2	150300	2	#10-16 x 1/2" Hex Washer TEK Screw
3	150008	2	#6-32 x 1-1/4" Phillips Pan Head Machine Screw
4	120701	1	4-Position Terminal Block
5	322812	1	Rear Electric Mounting Plate Only
	830470	1	Rear Electric Panel Assembly Complete – 208-240 Volt (includes illus. nos. 1 through 14)
6	132070	1	Transformer 208-240-24 Volt
7	136008	2	Fuse Holder
8	136057	2	1/2-Amp (Slo-Blo) Fuse
9	150301	2	#8-18 x 7/16" Phillips Pan Head TEK Screw
10	150297	1	#10 x 1/2" Green Hex Washer TEK Screw
11	152004	1	5/16-18 Hex Nut
12	121010	1	L-70 Ground Lug
13	153002	1	5/16" Lock Washer
14	131394	1	3-Pole Contactor
15	121300	3	Open / Closed Bushing

460-480V MP Rear Electric Relay Panel Assembly

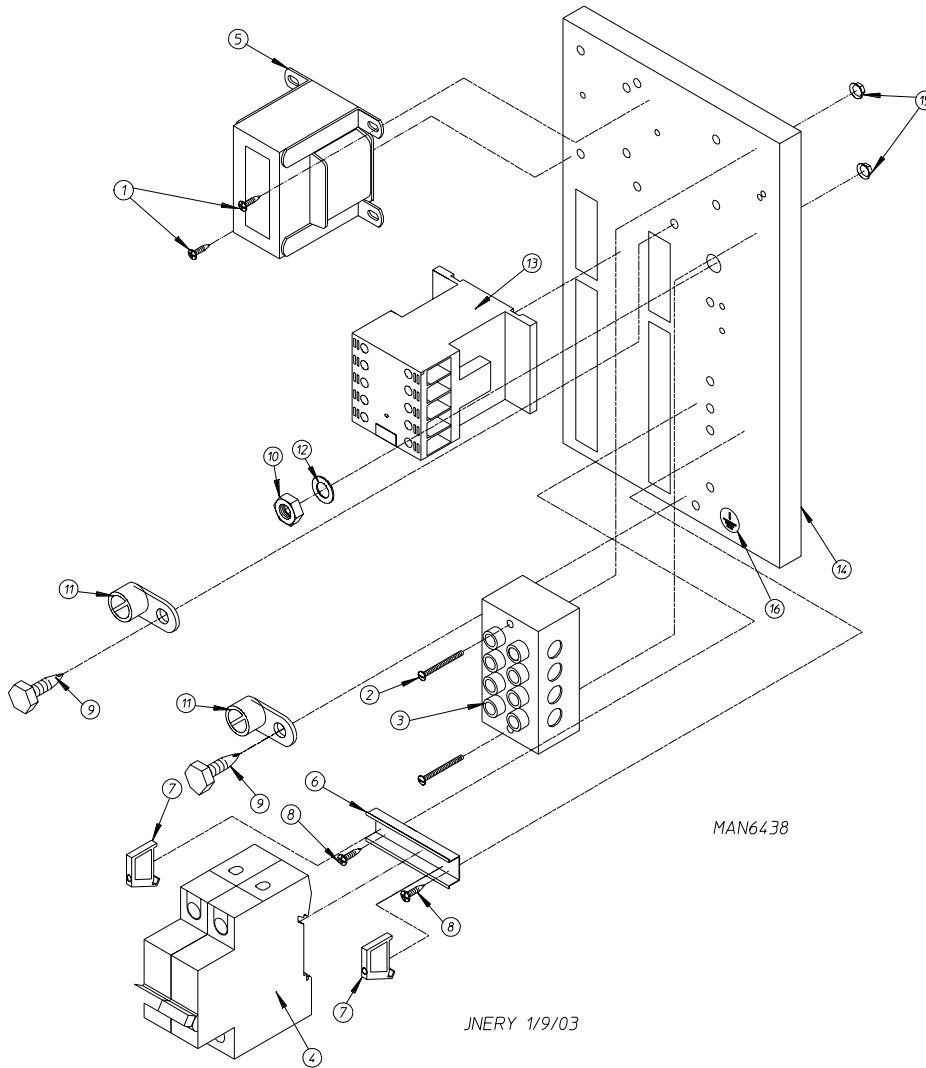

Illus. No.	Part No.	Qty.	Description
1	150300	2	#10-16 x 1/2" Hex Washer TEK Screw
2	150008	2	#6-32 x 1-1/4" Phillips Pan Head Machine Screw
3	120701	1	4-Position Terminal Block
4	136037	1	2-Pole Class C Fuse Holder ... Not Illustrated
	136114	2	1-Amp Class C Fuse ... Not Illustrated
	135501	1	2-Pole 1-Amp Circuit Breaker
5	132067	1	Transformer – 460-480 24 Volt
6	120768	2	35 x 15mm Din Rail
7	120765	2	End Stop
8	150301	2	#8-18 x 7/16" Phillips Pan Head TEK Screw
9	150297	2	#10 x 1/2" Green Hex Washer TEK Screw
10	152004	1	5/16-18 Hex Nut
11	121010	2	L-70 Ground Lug
12	153002	1	5/16" Lock Washer
13	131394	1	3-Pole Contactor
14	322812	1	Rear Electric Mounting Plate Only
	830474	1	Rear Electric Panel Assembly Complete – 460-480 Volt (includes illus. nos. 1 through 14)
15	151000	2	#6-32 Pal Nut
16	112075	1	Ground Label

208-240V MP Reversing Rear Electric Relay Panel Assembly

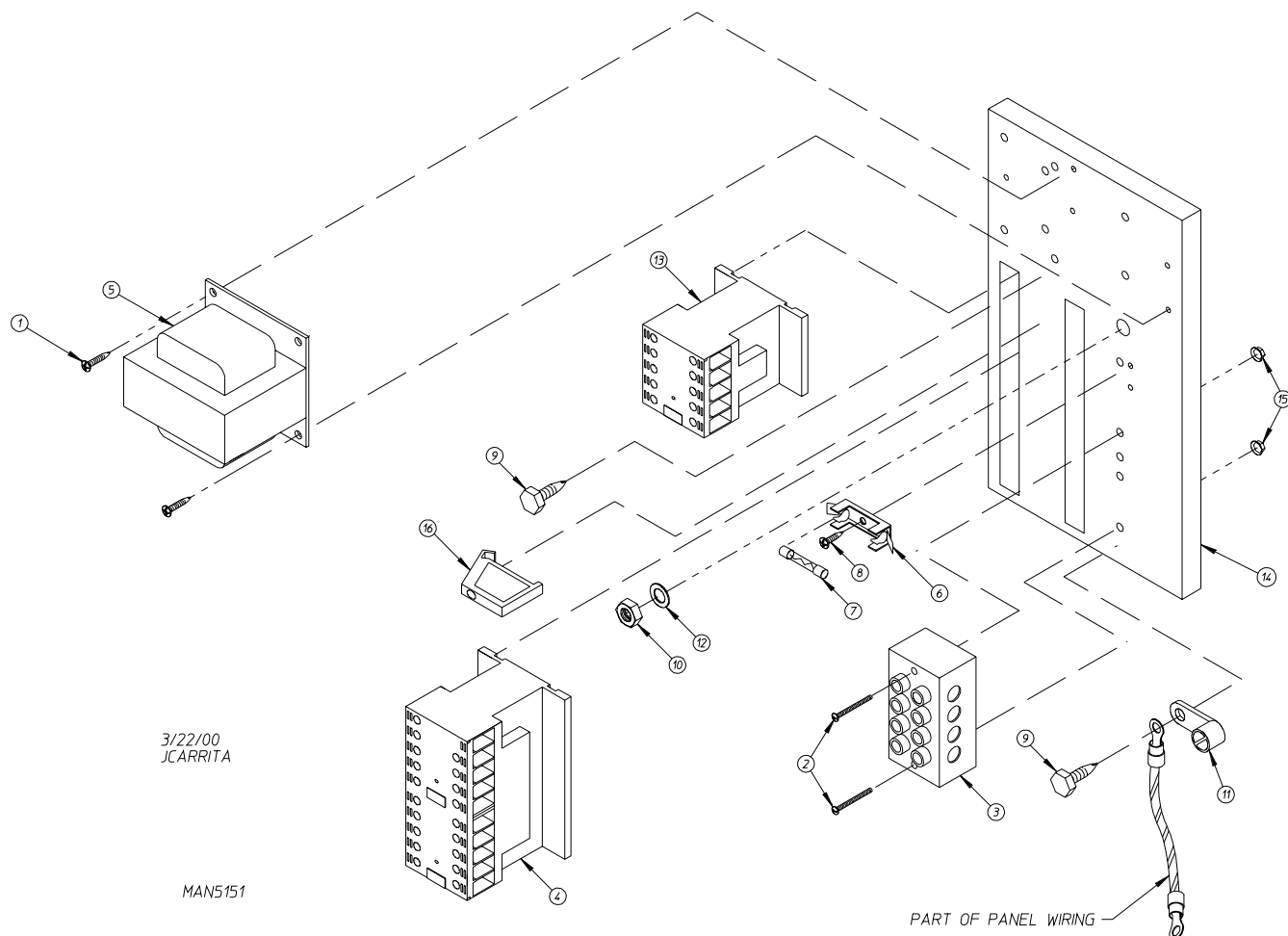

Illus. No.	Part No.	Qty.	Description
1	150300	2	#10-16 x 1/2" Hex Washer TEK Screw
2	150008	2	#6-32 x 1-1/4" Phillips Pan Head Machine Screw
3	120701	1	4-Position Terminal Block
4	131383	1	3-Pole Reversing Contactor
5	132070	1	Transformer 208-240 - 24 Volt
6	136008	2	Fuse Holder
7	136057	2	1/2-Amp (Slo-Blo) Fuse
8	150301	2	#8-18 x 7/16" Phillips Pan Head TEK Screw
9	150297	1	#10 x 1/2" Green Hex Washer TEK Screw
10	152004	1	5/16-18 Hex Nut
11	121010	1	L-70 Ground Lug
12	153002	1	5/16" Lock Washer
13	131394	1	3-Pole Contactor
14	321394	1	Rear Electric Mounting Plate Only
	830471	1	Rear Electric Panel Assembly Complete – 208-240 Volt (3Ø) (includes illus. nos. 1 through 16)
15	151000	2	#6-32 Pal Nut
16	120765	1	Standard End Bracket

460-480V MP Reversing Rear Electric Relay Panel Assembly

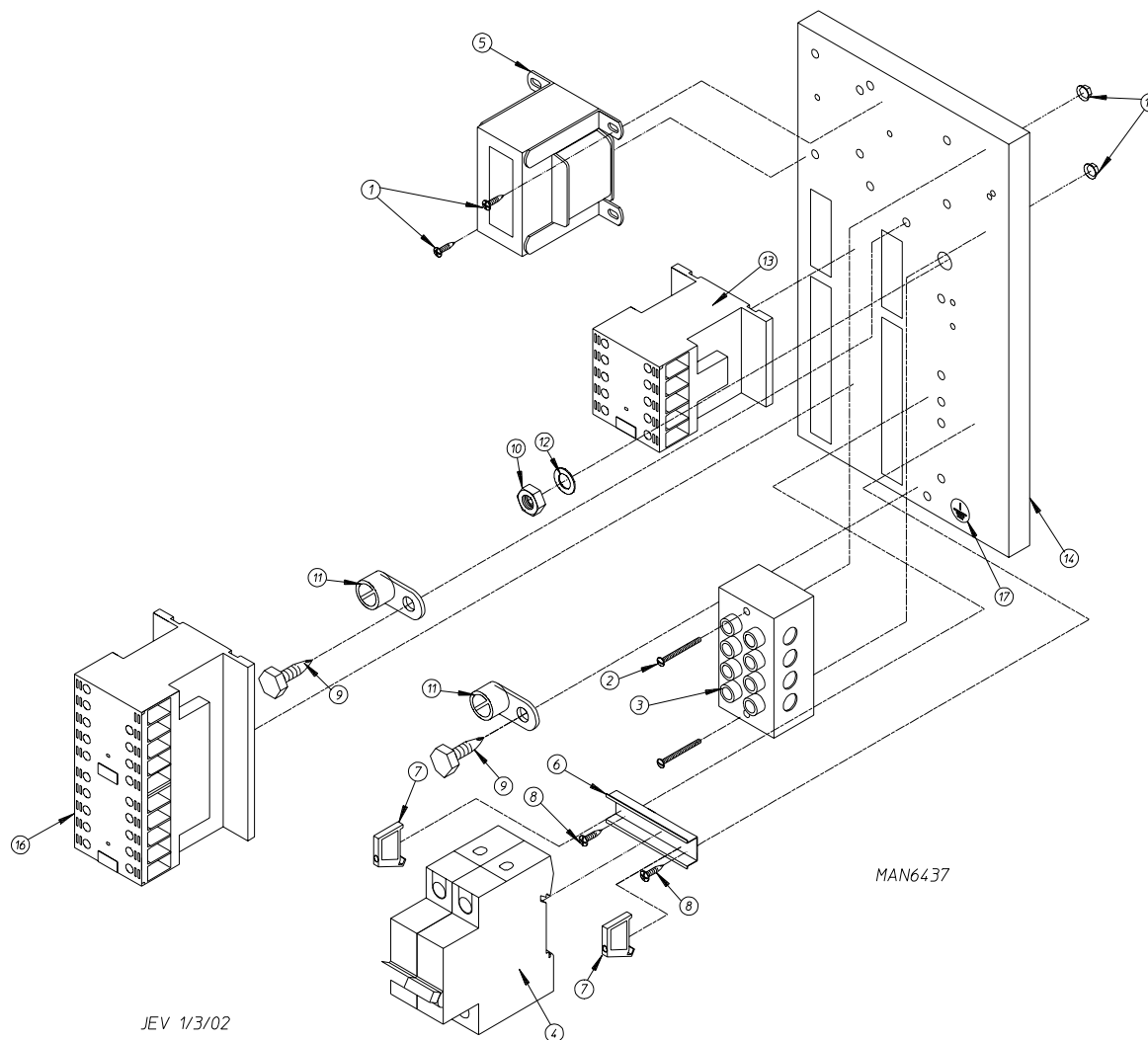

Illus. No.	Part No.	Qty.	Description
1	150300	2	#10-16 x 1/2" Hex Washer TEK Screw
2	150008	2	#6-32 x 1-1/4" Phillips Pan Head Machine Screw
3	120701	1	4-Position Terminal Block
4	136037	1	2-Pole Class C Fuse Block ... Not Illustrated
	136114	2	1-Amp Class C Fuse ... Not Illustrated
	135501	1	2-Pole 1-Amp Circuit Breaker
5	132067	1	Transformer 460-480 - 24 Volt
6	120768	2	35 x 15mm Din Rail
7	120765	2	Standard End Bracket
8	150301	2	#8-18 x 7/16" Phillips Pan Head TEK Screw
9	150297	2	#10 x 1/2" Green Hex Washer TEK Screw
10	152004	1	5/16-18 Hex Nut
11	121010	2	L-70 Ground Lug
12	153002	1	5/16" Lock Washer
13	131394	1	3-Pole Contactor
14	322812	1	Rear Electric Mounting Plate Only
	830475	1	Rear Electric Panel Assembly Complete - 460-480 Volt (includes illus. nos. 1 through 16)
15	151000	2	#6-32 Pal Nut
16	131383	1	3-Pole Reversing Contactor
17	112075	1	Ground Label

Single-Phase (1Ø) Dual Timer Rear Electric Relay Panel Assembly

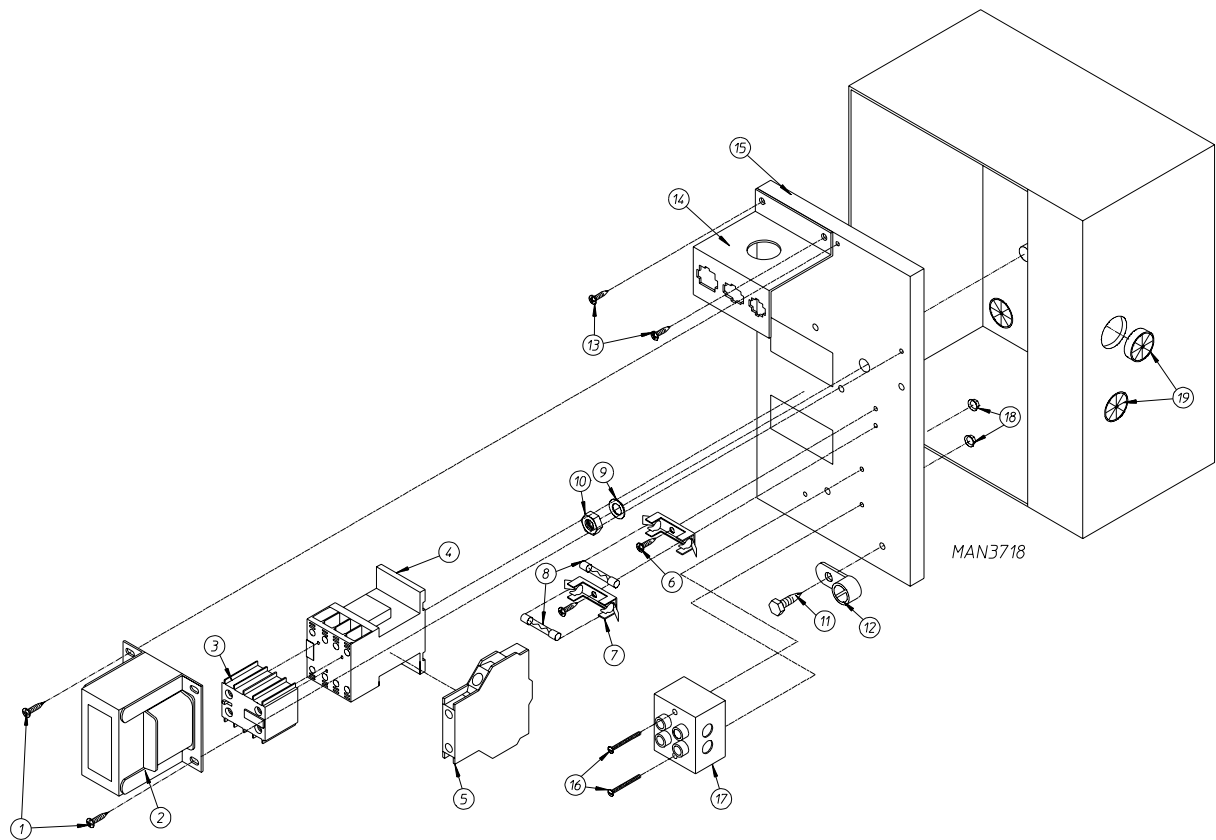

Illus. No.	Part No.	Qty.	Description
1	150300	2	#10-16 x 1/2" Hex Washer TEK Screw
2	141403	1	Transformer 120/208/240 - 24 Volt
3	132449**	1	2-Pole Contact Block (for 208-240 volt models Only)
4	132498	1	3-Pole Contactor
	131396	1	3-Pole Contactor (for 120 volt models Only)
	131394	1	3-Pole Contactor (for 208-240 volt models Only)
5	132383**	1	2-Pole Contact Block (for 120 volt models Only)
6	150301	*	#8-18 x 7/16" Phillips Pan Head TEK Screw
7	136008	*	Fuse Holder
8	136049	1	3/4-Amp (Slo-Blo) Fuse
	136057	2	1/2-Amp (Slo-Blo) Fuse
9	153002	1	5/16" Lock Washer
10	152004	1	5/16-18 Hex Nut
11	150297	1	#10 x 1/2" Green Hex Washer TEK Screw
12	121010	1	L-70 Ground Lug
13	150300	2	#10-16 x 1/2" Hex Washer TEK Screw
14	353258**	1	Rear Panel Connector Bracket
15	306304	1	Rear Electric Mounting Panel Only
	825445	1	Rear Electric Panel Assembly Complete – 115 Volt (for gas models without sail verification)
	825446	1	Rear Electric Panel Assembly Complete – 208-240 Volt (for gas models without sail verification)
16	150009	2	#6-32 x 1-1/2" Phillips Round Head Machine Screw
17	120716	1	2-Position Terminal Block
18	151000	2	#6-32 Pal Nut
19	121300	3	Open / Closed Bushing

* Quantity is 1 for 115v and 2 for 208-240v.

** Parts used on models with sail switch verification only.

460-480V Dual Timer Rear Electric Relay Panel Assembly

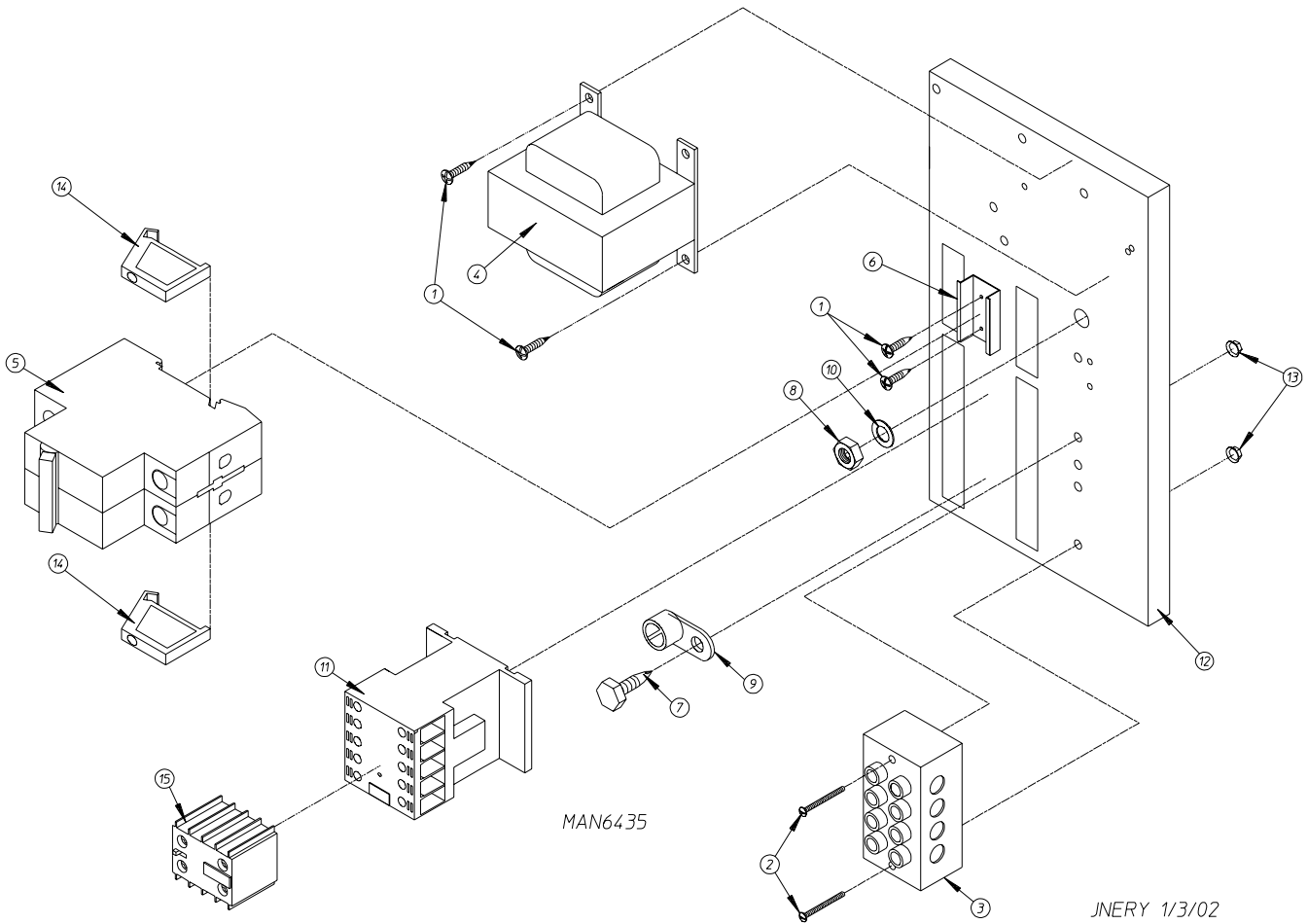

Illus. No.	Part No.	Qty.	Description
1	150300	2	#10-16 x 1/2" Hex Washer TEK Screw
2	150009	2	#6-32 x 1-1/2" Phillips Round Head Machine Screw
3	120701	1	4-Position Terminal Block
4	835143	1	24 VAC Transformer (for gas models Only)
5	136037	1	2-Pole Class C Fuse Block ... Not Illustrated
	136114	2	1-Amp Class C Fuse ... Not Illustrated
	135501	1	2-Pole 1-Amp Circuit Breaker
6	120768	2	35 x 15mm Din Rail
7	150297	1	#10 x 1/2" Green Hex Washer TEK Screw
8	152004	1	5/16-18 Hex Nut
9	121010	1	L-70 Ground Lug
10	153002	1	5/16" Lock Washer
11	131394	1	3-Pole Contactor
12	322812	1	Rear Electric Mounting Panel Only
	830474	1	Rear Electric Panel Assembly Complete (for gas models without sail verification) (includes illus. nos. 1 through 15)
13	151000	2	#6-32 Pal Nut
14	120765	2	Standard End Bracket
15	131391*	1	2-Pole Contact Block (for models mfd. as of September 15, 2009)
	132449*	1	2-Pole Contact Block (for models mfd. prior to September 15, 2009)

* Parts used on models with sail switch verification only.

208-240V Dual Timer Reversing Rear Electric Relay Panel Assembly

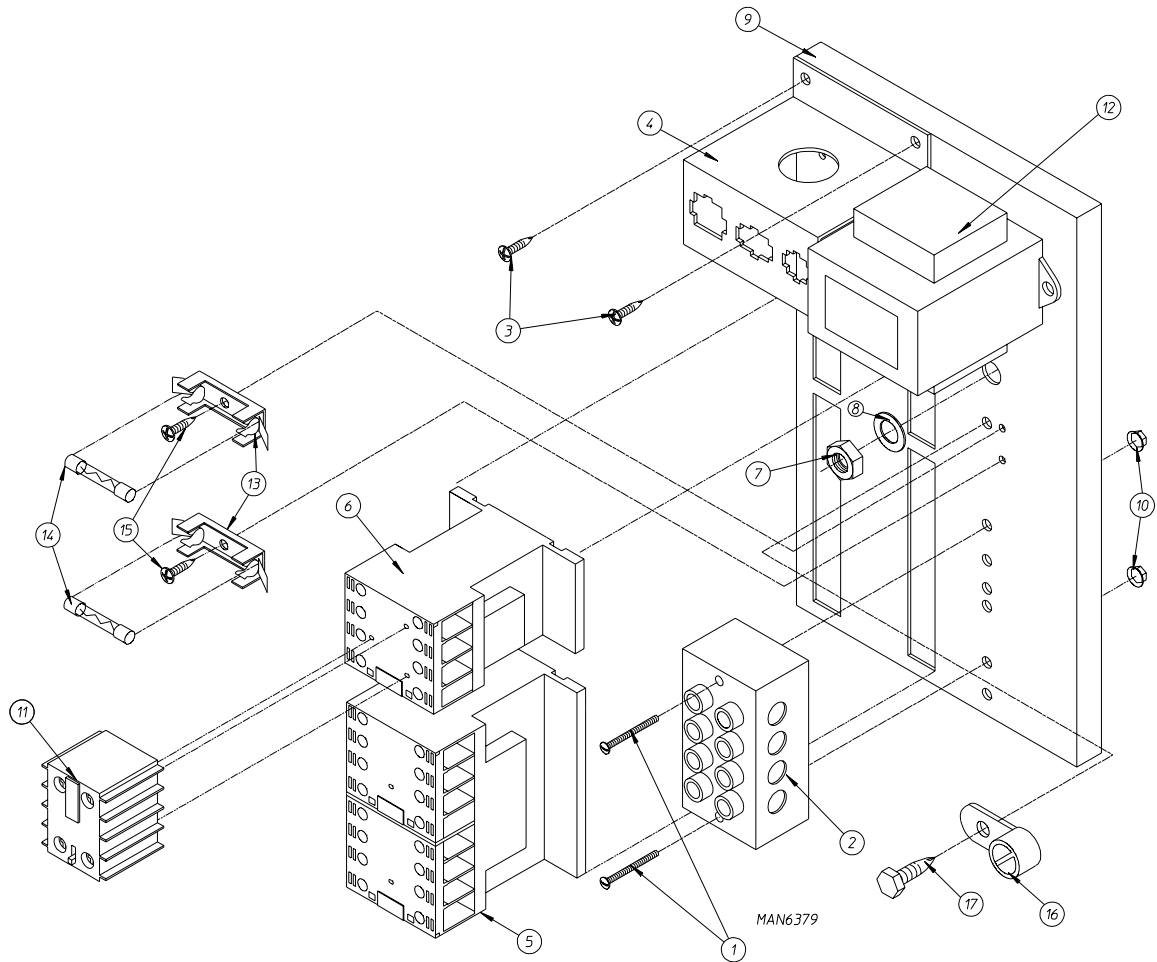

JCARRITA 11/15/02

Illus. No.	Part No.	Qty.	Description
1	150009	2	#6-32 x 1-1/2" Phillips Round Head Machine Screw
2	120701	1	4-Position Terminal Block
3	150300	2	#10-16 x 1/2" Hex Washer TEK Screw
4	353258	1	Rear Panel Connector Bracket
5	131383	1	Reversing Contactor
6	131394	1	Blower Motor Contactor
7	152004	1	5/16-18 Hex Nut
8	153002	1	5/16" Lock Washer
9	322812	1	Rear Electric Mounting Panel Only
	825452	1	Rear Electric Panel Assembly Complete (for gas models without sail verification) (includes illus. nos. 1 through 17)
10	151000	2	#6-32 Pal Nut
11	131391*	1	2-Pole Contact Block (for models mfd. as of September 15, 2009)
	132449*	1	2-Pole Contact Block (for models mfd. prior to September 15, 2009)
12	141403	1	24 VAC Transformer (for gas models Only)
13	136008	2	Fuse Holder
14	136057	2	1/2-Amp (Slo-Blo) Fuse
15	150301	2	#8-18 x 7/16" Phillips Pan Head TEK Screw
16	121010	1	L-70 Ground Lug
17	150297	1	#10 x 1/2" Green Hex Washer TEK Screw

* Parts used on models with sail switch verification only.

Non-Reversing Totally Enclosed, Fan-Cooled Motor Mount Assembly

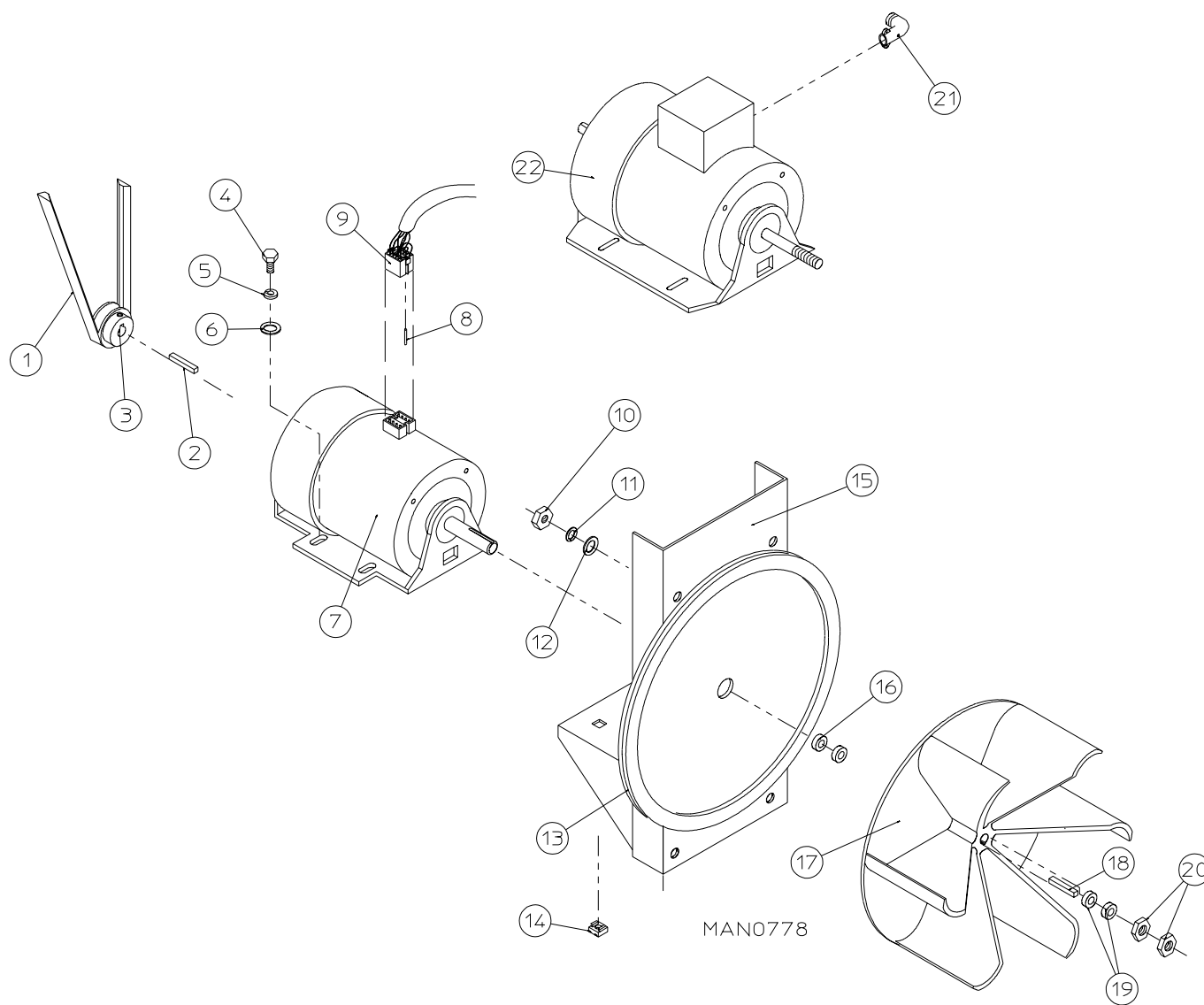

Non-Reversing Totally Enclosed, Fan-Cooled Motor Mount Assembly

<u>Illus. No.</u>	<u>Part No.</u>	<u>Qty.</u>	<u>Description</u>
1	100178	1	4L-570 V-Belt (motor to idler)
2	100701	1	3/16" x 3/16" x 1" Key
3	101133	1	5/8" x 2-1/4" Motor Pulley (60 Hz Only)
	101130	1	5/8" x 2-1/4" Motor Pulley (50 Hz Only)
4	150501	4	5/16-18 x 3/4" Hex Head Machine Bolt
5	153002	4	5/16" Lock Washer
6	153001	4	5/16" Flat Washer
7	100073*	1	1 hp 120/208/230v (1Ø) 60 Hz T.E.F.C. Motor with Plug (56Z frame)
	181050*	1	1 hp 200/240v (1Ø) 50 Hz Motor
8	122701	8	Socket Terminal
	122801	1	Pin / Socket Extraction Tool ... Not Illustrated
9	137030	1	8-Pin Housing Connector
	814764	1	120 Volt – 1Ø Motor Harness ... Not Illustrated
10	152004	4	5/16-18 Hex Nut
11	153002	4	5/16" Lock Washer
12	153001	4	5/16" Flat Washer
13	117604	4	Noise Suppression Tape (sold by the foot)
14	154000	4	5/16-18 Tinnerman Nut
15	803561	1	Non-Reversing Motor Mount Only (56Z frame)
	801801	1	1 hp 120/230v (1Ø) 60 Hz T.E.F.C. Motor Mount Assembly with Plug Complete (includes illus. nos. 2 through 7 and 13 through 20)
	801802	1	1 hp 230/380/460v (3Ø) 60 Hz Non-Reversing T.E.F.C. Motor Mount Assembly Complete (includes illus. nos. 2 through 6 and 13 through 22)
	801824	1	1 hp 240v (1Ø) 50 Hz T.E.F.C. Motor Mount Assembly with Plug Complete (includes illus. nos. 2 through 6 and 13 through 22)
16	153051	1	3/4" S.A.E. Flat Washer
17	882670	1	16" Impellor with 3/4" Bore
18	100714	1	3/16" x 3/16" x 1-7/8" Key
19	153050	2	1/2" S.A.E. Flat Washer
20	152006	2	1/2-20 Left-Hand Jam Nut
21	120200	1	3/8" x 90° Connector
	814772	1	3Ø Motor Harness ... Not Illustrated
22*	100075	1	1 hp 208/230/240/460v (3Ø) 50/60 Hz T.E.F.C. Motor

* Specify voltage when ordering.

Reversing Totally Enclosed, Fan-Cooled Motor Mount Assembly

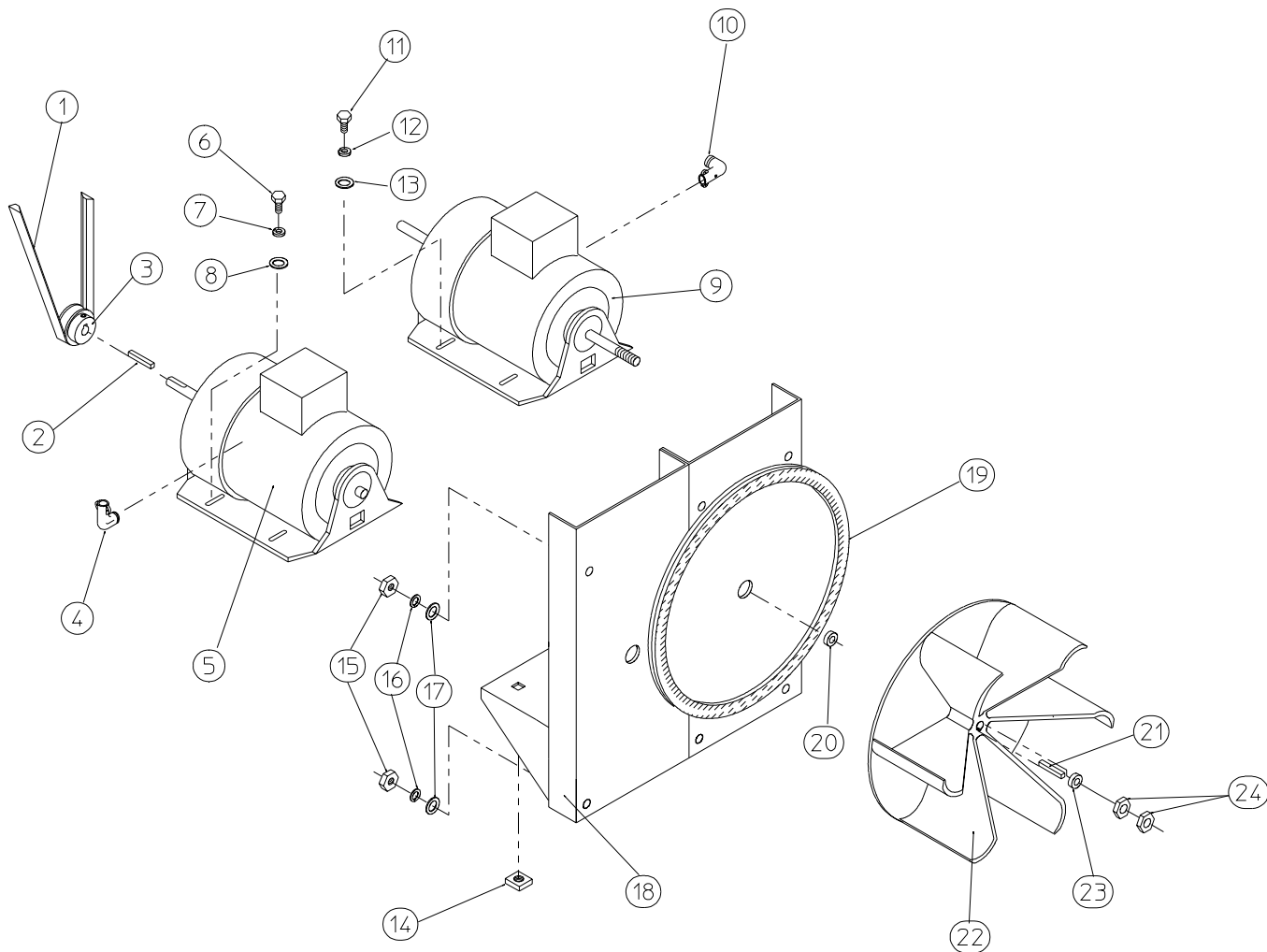

MAN0250

Reversing Totally Enclosed, Fan-Cooled Motor Mount Assembly

<u>Illus. No.</u>	<u>Part No.</u>	<u>Qty.</u>	<u>Description</u>
1	100178	1	4L-570 V-Belt (motor to idler)
2	100701	1	3/16" x 3/16" x 1" Key
3	101133	1	5/8" x 2-1/4" Motor Pulley (60 Hz Only)
	101130	1	5/8" x 2-1/2" Motor Pulley (50 Hz Only)
4	120200	1	3/8" x 90° Connector
	814780	1	3ø Drive Motor Harness
5*	181003	1	1/2 hp 208/230/380/460v (3ø) 50/60 Hz T.E.F.C. Motor (56Z frame)
6	150501	4	5/16-18 x 3/4" Hex Head Machine Bolt
7	153002	4	5/16" Lock Washer
8	153001	4	5/16" Flat Washer
9*	100075	1	1 hp 220/230/380/460v (3ø) 50/60 Hz T.E.F.C. Motor with 3/4" Shaft (56Z frame)
10	120200	1	3/8" x 90° Connector
	814779	1	3ø Blower Motor Harness
11	150501	4	5/16-18 x 3/4" Hex Head Machine Bolt
12	153002	4	5/16" Lock Washer
13	153001	4	5/16" Flat Washer
14	154000	8	5/16" Tinnerman Nut
15	152004	7	5/16" Hex Nut
16	153002	4	5/16" Lock Washer
17	153001	4	5/16" Flat Washer
18	817535	1	Reversing Motor Mount Only (56Z frame)
	817560*	1	Reversing T.E.F.C. Motor Mount Assembly Complete (for 60 Hz models Only) (includes illus. nos. 2 through 14 and 18 through 24)
	817561*	1	Reversing T.E.F.C. Motor Mount Assembly Complete (for 50 Hz models Only) (includes illus. nos. 2 through 14 and 18 through 24)
19	117604	4	Noise Suppression Tape (sold by the foot)
20	153050	1	1/2" S.A.E. Flat Washer
21	100702	1	1/8" x 1/8" x 1-1/2" Key
22	882670	1	16" Impellor with 3/4" Bore
23	153050	**	1/2" S.A.E. Flat Washer
24	152006	2	1/2-20 Left-Hand Jam Nut

* Specify voltage when ordering.

** As required.

Direct Spark Ignition Burner Assembly

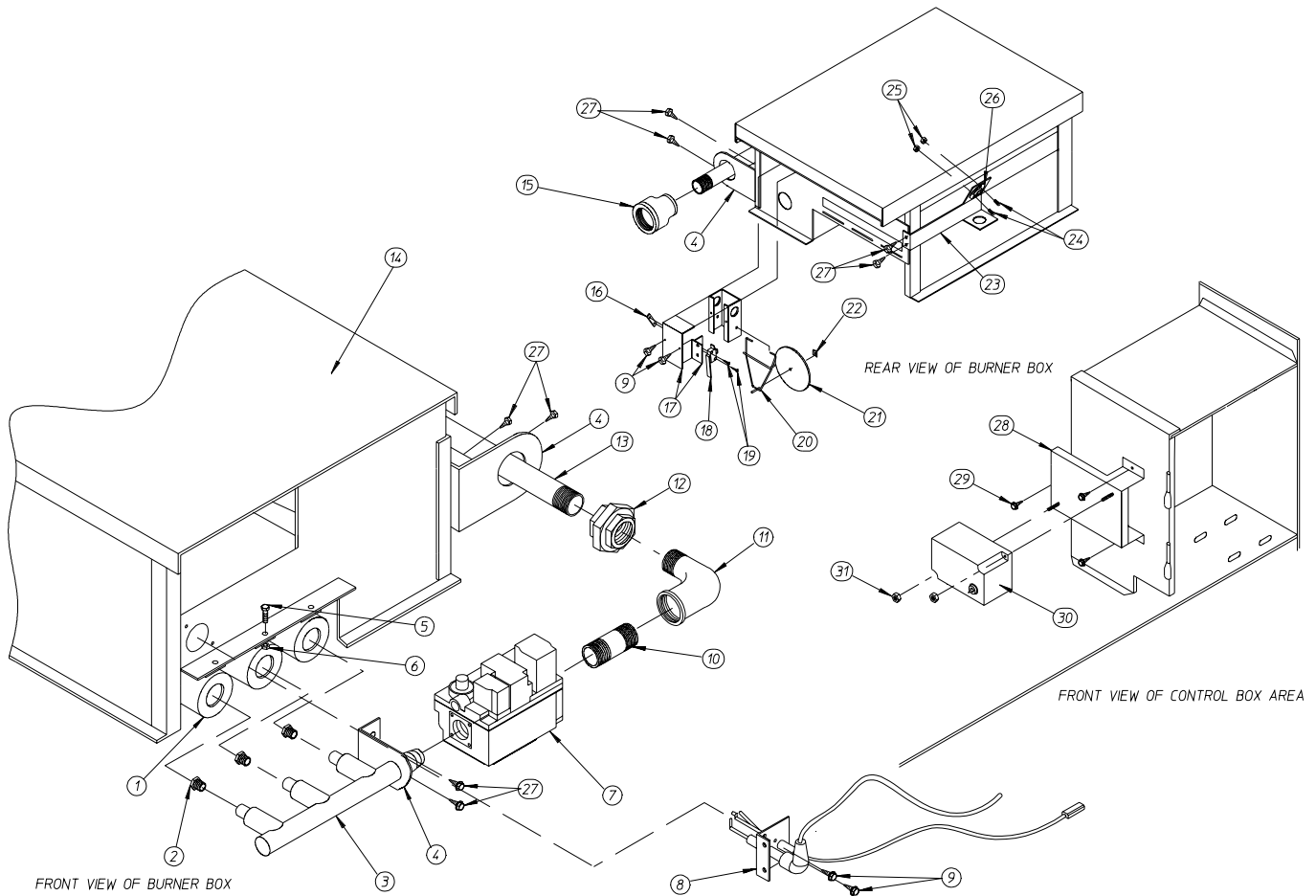

MFM 12/11/01

MAN6033

Direct Spark Ignition Burner Assembly

<u>Illus. No.</u>	<u>Part No.</u>	<u>Qty.</u>	<u>Description</u>
1	141105	3	Large Tube Burner
2	140856	3	#23 Burner Orifices (natural gas) Only
	140810	3	#42 Burner Orifices (liquid propane gas) Only
3	141232	1	1/2" Direct Spark Ignition Manifold (3-port)
4	318700	3	Pipe Bracket (bent)
5	150108	3	#8-32 x 1/2" Pan Head Machine Screw
6	151001	3	#8-32 Pal Nut
7	128927	1	Gas Valve
8	884265	1	Ignitor Probe Assembly
	884279	1	High Voltage Wire with 1/4" Spade Connection
	883031	1	High Voltage Wire with Socket Connection (for models with spike style connection at module)
9	150300	4	#10-16 x 1/2" Hex Washer TEK Screw
10	142707	1	1" x 1-1/2" Nipple
11	142506	1	1/2" x 1/2" Street Elbow
12	142600	1	1/2" Black Union
13	142804	1	1/2" x 24" Pipe
14	801704	1	Direct Spark Ignition Burner Assembly (natural gas) Only (includes illus. nos. 1 and 3 through 27)
	801705		Direct Spark Ignition Burner Assembly (liquid propane gas) Only (includes illus. nos. 1 and 3 through 27)
15	143000	1	1/2" x 3/4" Reducing Coupling
16	154004	1	Twin Speed Nut
17	802799	1	Sail Switch Top and Switch Bracket
18	122200	1	Sail Switch
19	150303	2	#4 x 3/4" Pan Head "A" Machine Screw
20	105500	1	Sail Switch Actuator Rod
21	319202	1	Sail Switch Damper (flat)
22	154002	1	1/8" Push-On Fastener
23	319704	1	Hi-Limit Mounting Bracket
24	150001	2	#6-32 x 1/2" Round Head Machine Screw
25	151000	2	#6-32 Pal Nut
26	130201	1	330° Hi-Limit Manual Reset
27	150309	8	#10-16 x 1/2" Hex Head TEK Crimptite Screw
28	810030	1	Direct Spark Ignition Mounting Bracket
29	150300	3	#10-16 x 1/2" Hex Washer TEK Screw
30	883849	1	Direct Spark Module Kit (includes high voltage wire)
31	152013	2	#6-32 Hex Nut

Sail Switch Assembly

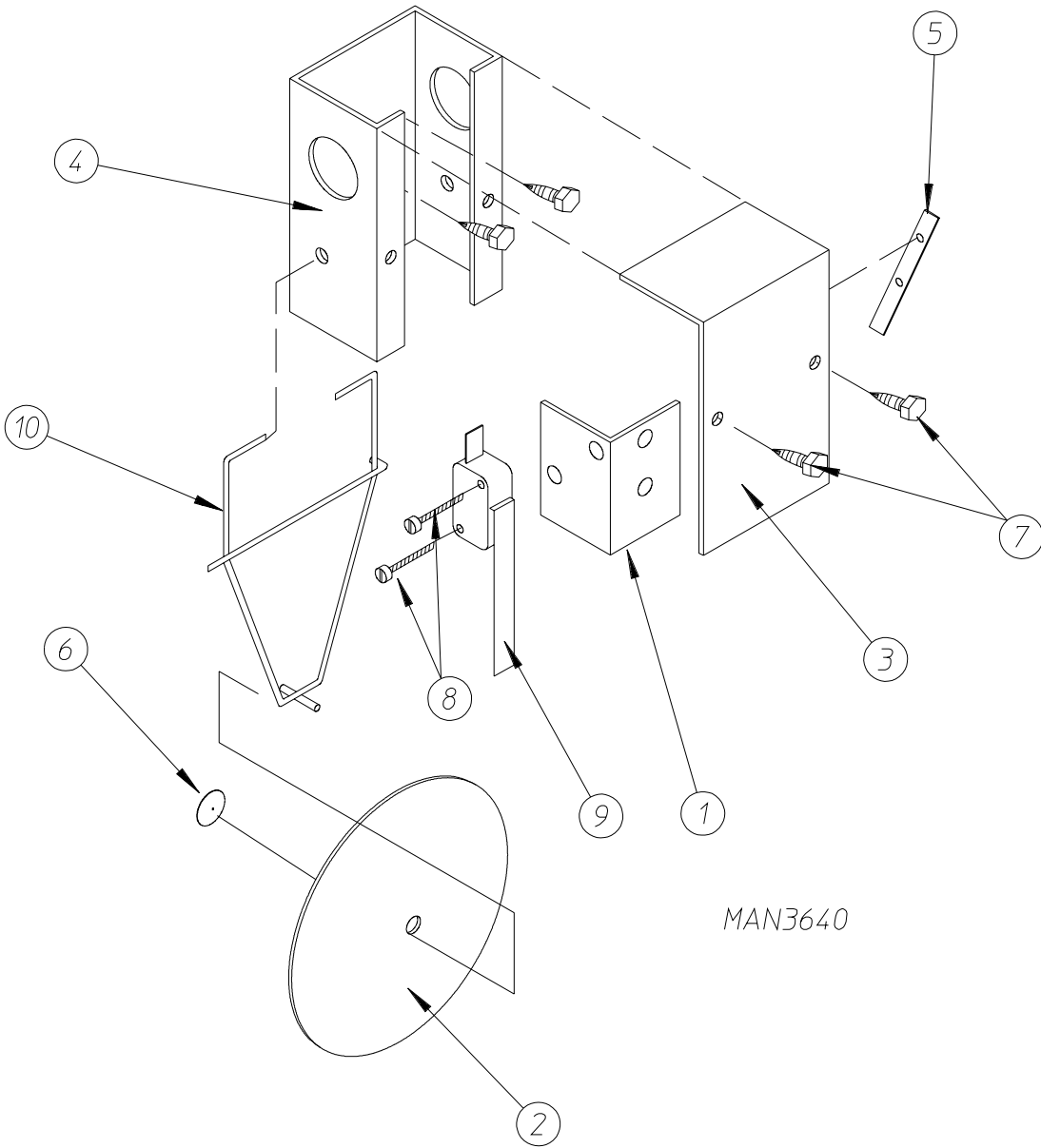

MAN3640

<u>Illus. No.</u>	<u>Part No.</u>	<u>Qty.</u>	<u>Description</u>
1	319203	1	Sail Switch Mounting Bracket
2	319202	1	Sail Switch Damper (flat)
3	319201	1	Sail Switch Box Cover
4	319200	1	Sail Switch Box
5	154004	1	Twin Speed Nut
6	154002	1	1/8" Push-On Fastener
7	150309	4	#10-16 x 1/2" Hex Head TEK Crimptite Screw
8	150303	2	#4 x 3/4" Pan Head "A" Machine Screw
9	122200	1	Sail Switch Only
	881706	1	Sail Switch Box Assembly Complete (includes illus. nos. 1 through 10)
10	105500	1	Sail Switch Actuator Rod

Fire Suppression System Assembly

For Models Mfd. as of November 8, 2011

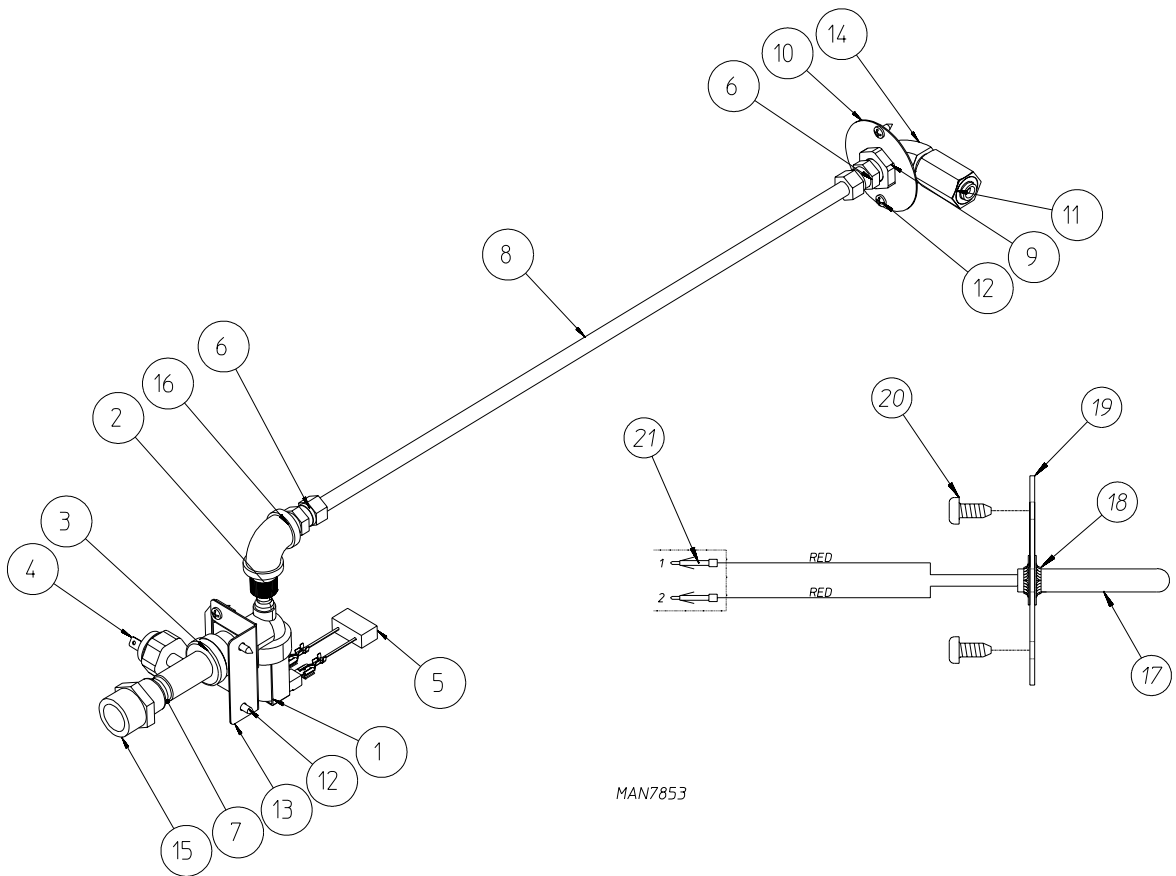

MAN7853

<u>Illus. No.</u>	<u>Part No.</u>	<u>Qty.</u>	<u>Description</u>
1	165119	1	Fire Suppression System H ₂ O Valve 24VAC
2	143183	1	7/16-20 x 3/8 NPD Brass Adaptor
3	143182	1	3/4GHT x 1/8 x 3/8 NPT Brass Tee
4	136987	1	Water Pressure Switch
5	824081	1	RC Network Assembly
6	143208	2	3/8 Comp x 3/8 MPT Brass Connect
7	143241	1	3/8 x Close Brass Nipple
8	143099	20	3/8" OD x .035 Wall Copper Tubing
9	143303	1	3/8 NPT Brass Lock Nut
10	311588	1	Fire Suppression System Sprinkler Head Mounting Plate
11	143581	1	Fire Suppression System 3GPM 3/8 NPT Spray Nozzle
12	150301	6	#8-18 x 7/16 PHL-PH-TEX PLTD
13	313962	1	Main Line F.S.S. 90° Valve Bracket
14	143155	1	3/8 Brass Street Elbow
15	143356	1	3/4 Male x 3/8 FNPT Brass Bushing
16	143310	1	3/8 Brass 90° Elbow
—	817576	1	Fire Suppression System Assembly Complete (includes illus. nos. 1 through 16)
17	822752	1	Fire Suppression System Temperature Probe Assembly (includes illus. nos. 17 through 19 and 21)
18	159007	2	Push-On Fastener
19	390390	1	Sensor Bracket ONLY
20	150301	2	#8-18 x 7/16" Phillips Pan Head TEK Screw
21	122647	1	Connector ONLY (does not include terminals)

Fire Suppression System Assemblies

For Models Mfd. prior to November 8, 2011

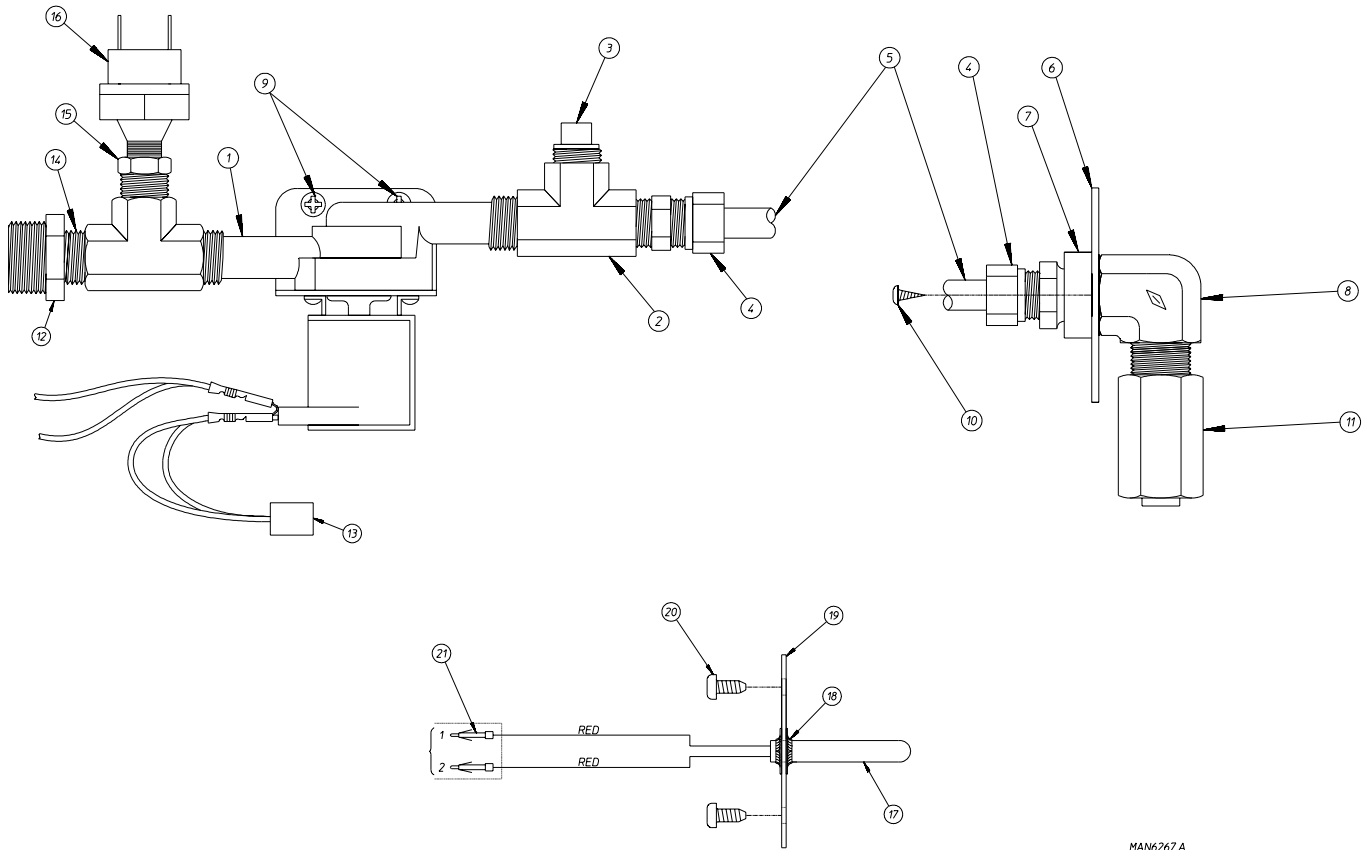

MAN6267.A

<u>Illus. No.</u>	<u>Part No.</u>	<u>Qty.</u>	<u>Description</u>
1	165114	1	Fire Suppression System Solenoid Valve 24V 50/60 Hz
2	143220	2	3/8" F.P.T. Brass Tee
3	143251	1	3/8" M.P.T. Brass Plug
4	143208	2	3/8" Comp x 3/8" M.P.T. Brass Connector
5	143099	6'	3/8" OD x 0.035 Wall Copper Tubing (sold by the foot)
6	311588	1	Sprinkler Head Mounting Plate
7	143303	1	3/8" N.P.T. Brass Locknut
8	143155	1	3/8" Brass Elbow 90°
9	150300	2	#10-16 x 0.5 Hex TEK Screw
10	150301	2	#8-18 x 7/16" TEK Screw
11	143581	1	3 GPM 3/8" F.P.T. Spray Nozzle
12	143356	1	3/4 Male x 3/8 FNPT Brass Bushing
13	824081	1	R.C. Network Assembly
14	143241	1	3/8" x Close Brass Nipple
15	143315	1	3/8" M.N.P.T. x 1/8" F.N.P.T. Brass Bushing
16	136987	1	Water Jet Pressure Switch (for models mfd. as of December 1, 2003)
	817459	1	Fire Suppression System Assembly Complete (includes illus. nos. 1 through 16)
17	822752	1	Fire Suppression System Temperature Probe Assembly (includes illus. nos. 17 through 19 and 21)
18	154007	2	Push-On Fastener
19	390390	1	Sensor Bracket ONLY
20	150301	2	#8-18 x 7/16" Phillips Pan Head TEK Screw
21	122647	1	Connector ONLY (does not include terminals)

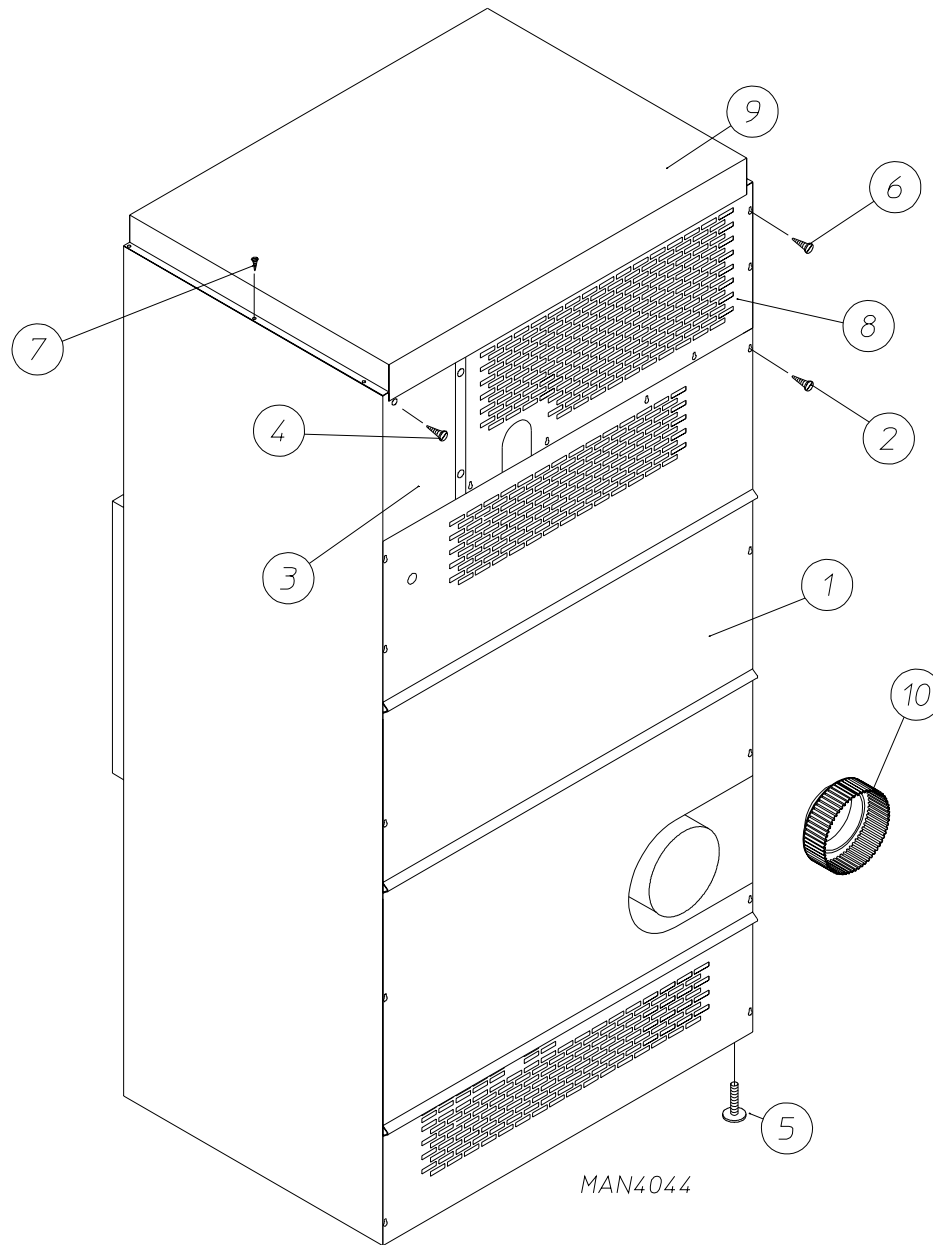

<u>Illus. No.</u>	<u>Part No.</u>	<u>Qty.</u>	<u>Description</u>
1	314501	1	Bottom Back Guard (for models mfd. as of July 13, 1998)
2	150301	12	#8-18 x 7/16" Phillips Pan Head TEK Screw
3	322809	1	Rear Electrical Box Cover
4	150301	4	#8-18 x 7/16" Phillips Pan Head TEK Screw
5	103500	4	Leveling Leg
6	150301	7	#8-18 x 7/16" Phillips Pan Head TEK Screw
7	150301	12	#8-18 x 7/16" Phillips Pan Head TEK Screw
8	314738	1	Top Back Guard
9	314737	1	Outer Top
10	882099	1	8" to 10" Increaser

Additional Parts Available

<u>Part No.</u>	<u>Description</u>
114001	“CAUTION – Exhausted” Label
114004	“CAUTION – Rotating Parts”
114006	“WARNING – Fire Hazards” Label
114007	“DANGER – High Voltage”
114008	“WARNING – Fumes”
114072	“Exhaust Warning”
114533	120V Electric Service Label
120100	3/8” Straight (BX) Connector
120300	3/8” x 45° (BX) Connector
120400	3/8” Red Jacket (BX) Insulator
120500	3/8” Jiffy Clip (BX retainer clip)
120600	3/8” Greenfield (BX) Flexible Steel Conduit
120800	1/4” In-Line Connector
120802	Red Butt Connector
120902	#74B Wire Nut
120903	Crimp-On Wire Nut
121499	5-1/2” Harness Tie
121500	8” Harness Tie
122566	1/4” Insulated (female) Terminal
122672	Mini-Fit Extraction Tool
122804	Manometer (hydro gauge) for Measuring Gas Pressure
404502	White Brush-In-Cap Bottle Touch-Up Paint
404507	Cornflower Blue Brush-In-Cap Bottle Touch-Up Paint
882458	Tumbler Bearing Puller
883830	Gas Valve Tail Piece Removal Tool

