



Section: 7

Parts Data

DC30X2

24VAC Control

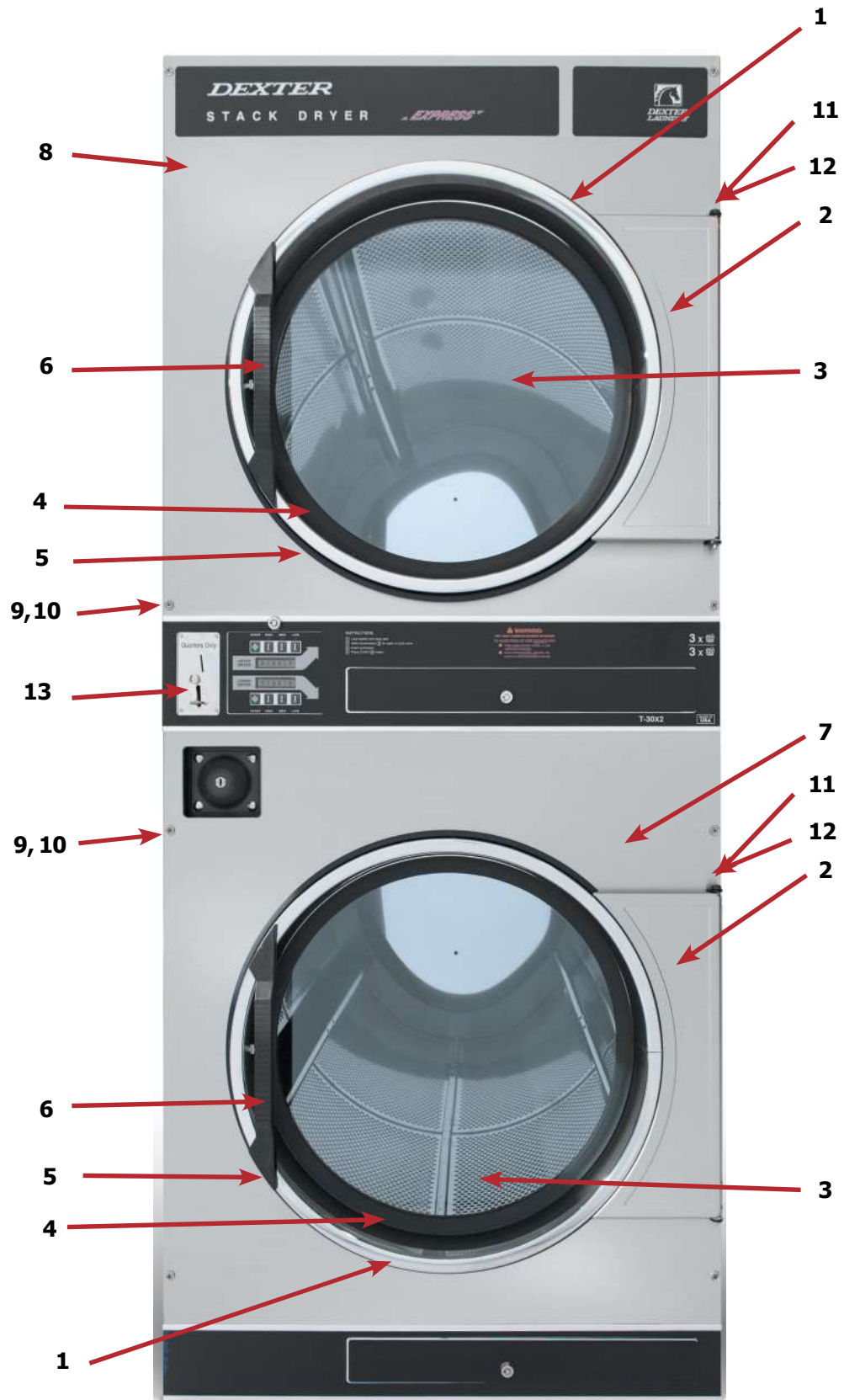

Parts Data

Cabinet Group

Key	Part Number	Description	Quantity
*	9960-256-038	Door Assy., Loading Complete-Wht	2
*	9960-256-039	Door Assy., Loading Complete-SS	2
*	9960-256-035	Door Assy., Loading Complete-Chrome SS/CHR/BLK	2
1	9960-255-008	Door Assy., Loading-SS(ring only)	2
1	9960-255-016	Door Assy., Loading-Chrome(ring only)	2
2	9982-280-014	Plate Assy., Hinge (Wht) No Pin	2
2	9982-280-012	Plate Assy., Hinge (SS) No Pin.....	2
*	9545-012-015	Screw, Hinge to Door	8
*	8640-413-002	Nut, Hinge to Door	8
3	9212-002-003	Glass, Door	2
4	9206-413-001	Gasket, Glass, Black.....	2
*	9548-117-000	Support, Door Glass	2
*	8545-064-001	Tool Install Dryer Glass Gasket	1
5	9206- 420-003	Gasket, Outer Rim Black.....	2
6	9244-082-001	Handle, Loading Door	2
*	9545-018-017	Screw, Handle 1/4-20 x 3/8	2
*	9531-033-001	Stud, Door Catch	2
*	8640-413-001	Nut, Hex	2
*	8640-413-003	Nut, Acorn	2
*	9086-015-002	Catch, Loading Door	2
*	8638-190-009	Pop Rivet for mtg. catch	4
*	8641-582-006	Lockwasher.....	4
*	8640-399-001	Spring Nut	6
7	9989-569-003	Panel Assy., Front- Lower (Wht) (LRG Vault).....	1
7	9989-569-001	Panel Assy., Front- Lower (SS) (LRG Vault).....	1
8	9989-568-003	Panel Assy., Front- Upper (Wht)	1
8	9989-568-001	Panel Assy., Front- Upper (SS)	1
9	9545-008-014	Screw Phillips 10B x 1 3/4".....	8
10	8641-585-001	Washer Finish	8
11	9544-072-002	Strap, Hinge (Black)	2
*	9452-819-001	Plate Hinge Backup.....	2
*	9345-008-020	Screw, Hinge to Panel	8
12	9545-052-001	Screw, Door to Hinge Strap (Special Black Type)	2
*	8641-436-003	Washer, Fiber	2
13	9021-041-001	Acceptor-Coin, Optical	1
*	9486-149-001	Retainer, Coin Acceptor	2
14	9545-053-002	Screw	4
*	9801-099-001	Switch, Optical (Replacement)	1

Cabinet Group Continued

Key	Part Number	Description	Quantity
14	9994-046-001	Escutcheon, Upper	1
15	9435-061-002	Trim, Overlay-Upper, Blue	1
15	9435-061-001	Trim, Overlay-Upper, Black.....	1
*	9545-020-009	Screw, #4-40 x 3/16.....	10
16	9994-048-001	Escutcheon, Lower	1
17	9435-063-001	Trim, Overlay-Lower, Blue	1
17	9435-063-001	Trim, Overlay-Lower, Black.....	1
*	9545-020-009	Screw, #4-40 x 3/16.....	10
18	9412-167-002	Nameplate Stack Dryer Express, Blue1
18	9412-167-001	Nameplate Stack Dryer Express, Black1
19	8650-012-003	Lock and Key, Lint Drawer #6101	2
*	6292-006-010	Key 6101 only for Lint Drawer	AR
*	9095-043-001	Cam, Lock Lint Drawer2
*	9627-859-003	Harness, Main-Electronic Control1
20	9857-198-002	Controls Assy, 24V, BLU	1
20	9857-198-004	Controls Assy, 24V, BLK	1
21	9435-038-002	Overlay-Control, Blue	1
21	9435-038-001	Overlay-Control, Black	1
22	8650-012-003	Lock and Key, Control #6324	1
*	9095-041-001	Cam, Lock	1
*	6292-006-007	Key 6324 only for Computer.....	1
*	9150-045-001	USB, Thumbdrive.....	1
*	9627-855-001	Harness, Heat Sensor.....	1
*	8640-276-002	Wire Nut Connector Grey.....	4
23	9501-006-001	Sensor Temp Control (serial #200588).....	2
24	9486-137-002	Retainer - Push On.....	2
*	9209-037-002	Grommet, 3/16 ID	2
25	9866-004-001	Lint Drawer Assembly, Blue2
25	9866-004-011	Lint Drawer Assembly, Black2
26	9435-003-009	Overlay trim, lint drawer, Blue	1
26	9435-029-001	Overlay trim, lint drawer, Black.....	1
*	9532-143-001	Felt Seal (back of lint screen assembly)	2
*	9805-038-001	Lint Screen Assembly ONLY (no front)	2
*	9555-057-002	Replaceable Lint Screen Only2
*	9545-008-001	Screws 10Bx 1/4 Lint Screen Strap Hold Down	32
*	8544-006-001	Leg, Leveling 1/2"	4
*	9074-365-001	Cover, Cabinet (Top).....	1
*	9277-041-011	Insulation Cabinet Cover1
*	9732-253-001	DDAD Kit for Dryers without Neutral and using 208-240 volt	1
*	9732-102-011	LP Kit for DDAD Dryers.....	1
*	9555-057-003	Replaceable Lint Screen Fine Mesh Only1
*	9277-063-001	Insulation-Front Panel-Top Half	2
*	9277-063-002	Insulation-Front Panel-Lower Half.....	2
*	9527-007-001	Standoff Wire Saddle.....	8
*	9544-041-002	Strap - Bead Tie.....	1
27	9942-038-005	Vault, Coin Box	1
*	9545-008-024	Screws, Mounting-Coin Vault	2
28	9807-099-002	Coin Box Assy, Large Blue	1
28	9807-099-004	Coin Box Assy, Large Black	1

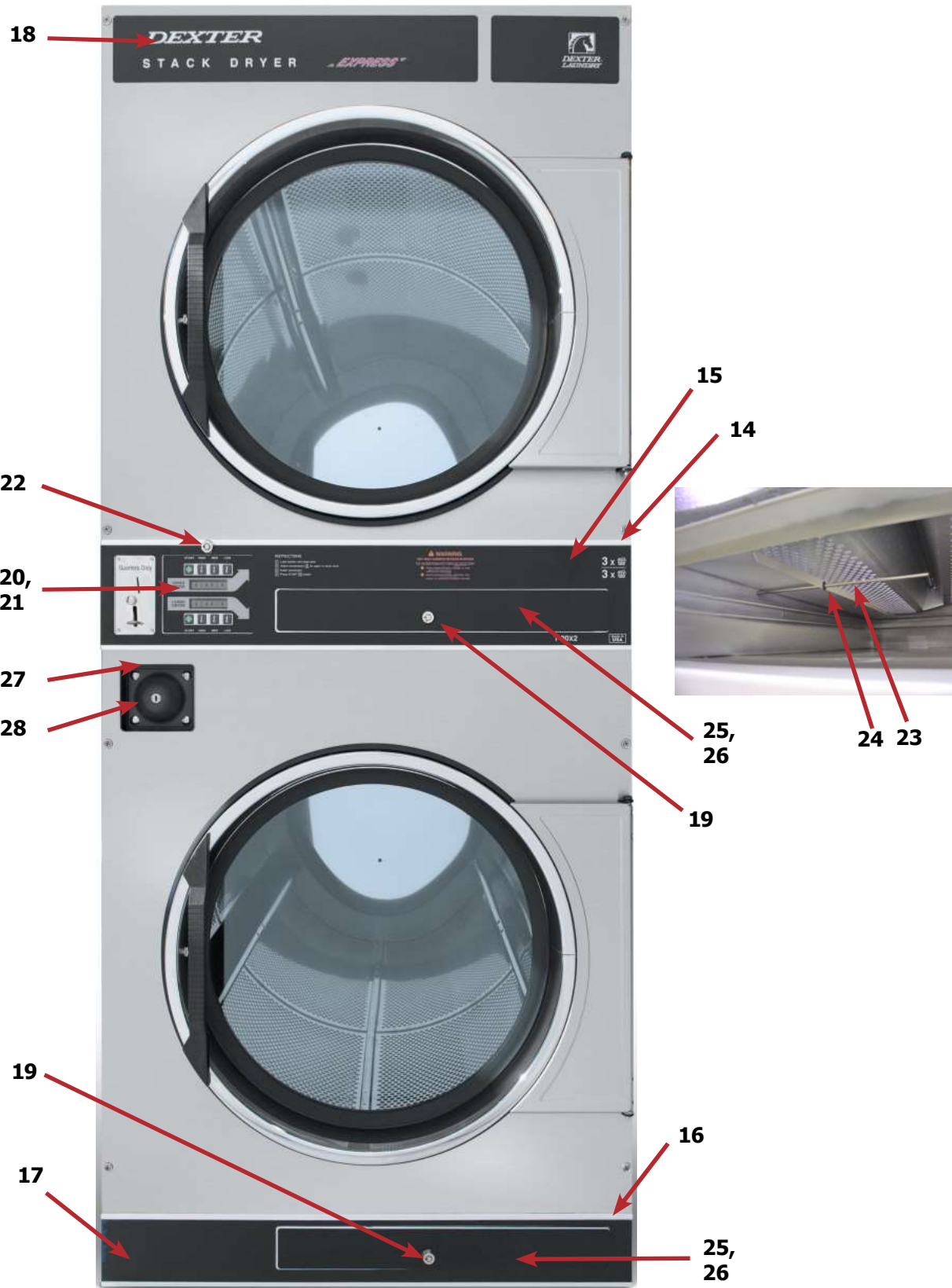

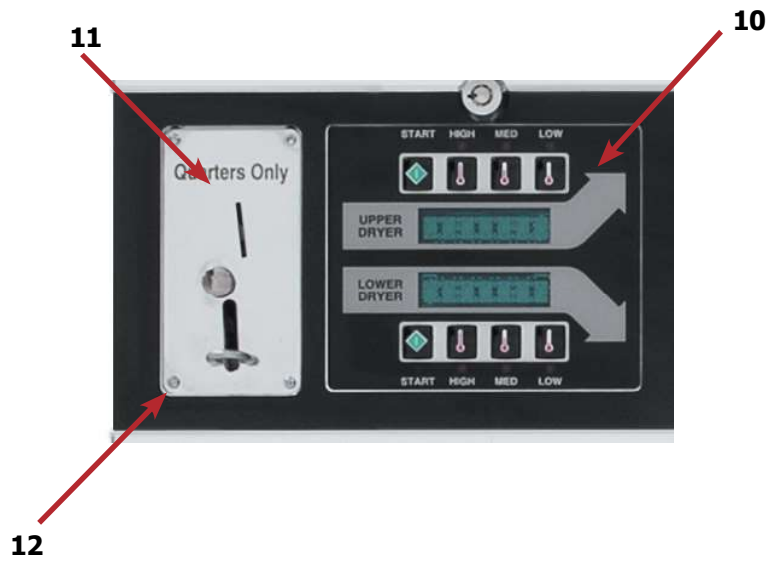
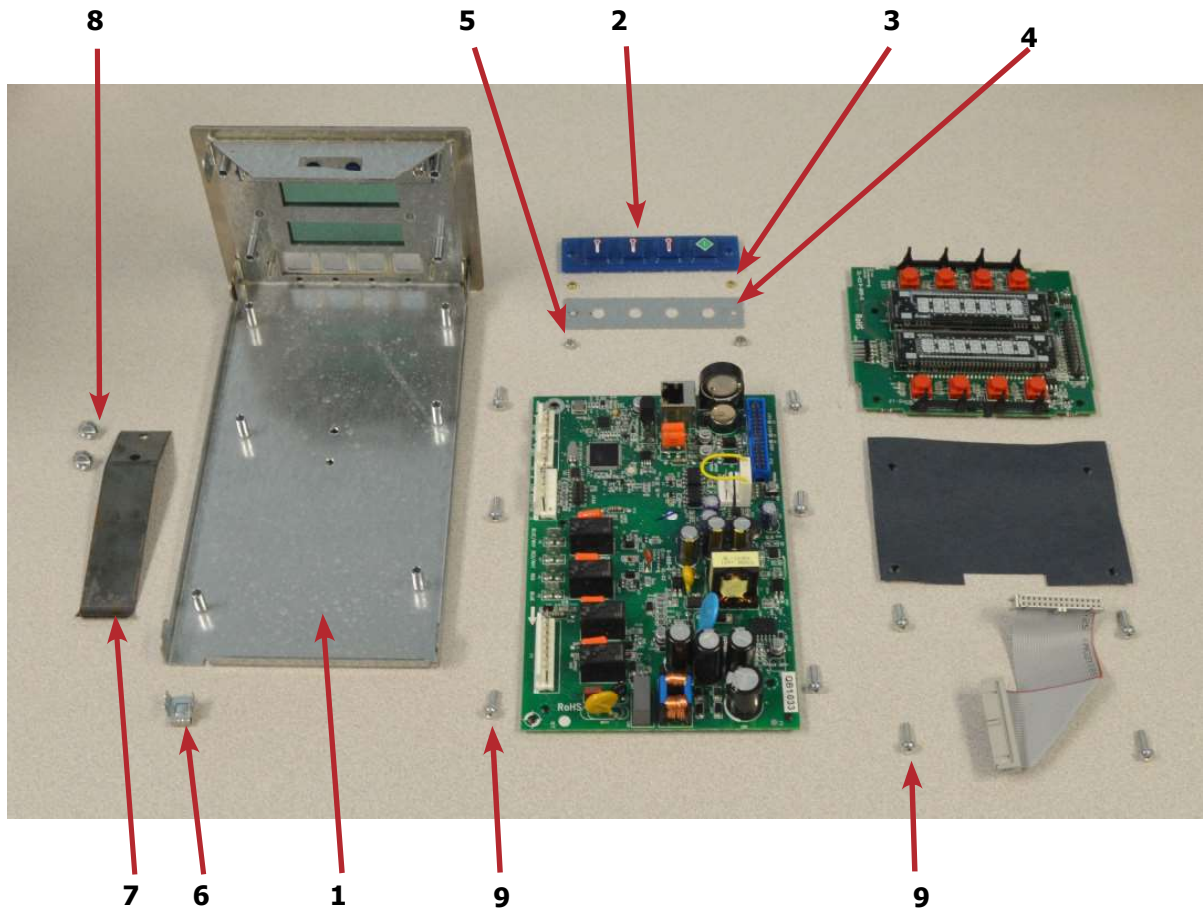

Control Parts Group

Key	Part Number	Description	Quantity
*	9857-198-002	Controls Assy, 24V, BLU	1
*	9857-198-004	Controls Assy, 24V, BLK	1
1	9826-008-001	Trough Assembly	1
2	9035-062-002	Button-Push, Control, Black	2
2	9035-062-001	Button-Push, Control, Blue.....	2
3	9538-166-011	Spacer-Metal, 4mm	4
4	9486-158-001	Retainer-Push Button	2
5	8640-424-002	Nut-Hex, Elastic stop, #4-40	4
6	8652-130-038	Terminal-Grounding clip	1
7	9534-365-001	Spring-Flat, Control	1
8	9545-008-001	Screw-Hex, #10B x 1/4	2
9	9545-044-010	Screw-Hex, #10B x 1/4	10
9	8641-582-005	Washer-External tooth, #6	10
10	9435-038-001	Overlay-Control, Coin, Black	1
10	9435-038-002	Overlay-Control, Coin, Blue	1
11	9021-041-001	Acceptor-Coin, Optical	1
*	9486-136-001	Retainer, Coin Acceptor	1
12	9545-053-002	Screw	4
*	9801-099-001	Optical Sensor, Replacement.....	1

Note: Jumpers required if using 1.5 Control on Older Machines (P9 Connection)

*	8220-155-001	Wire Assy, Jumper, 30Lb Stack Coin	1
*	8220-155-002	Wire Assy, Jumper, 50Lb Stack Coin	1

Hinge Plate Cover

1	9074-341-002	Cover-Hinge, Black	2
Note: Before Serial # 220625 Holes can be drilled in hinge plate to install (#18 Drill bit).			
2	8636-018-017	Screw-TRHDCR, 10B x 3/8, Black.....	4

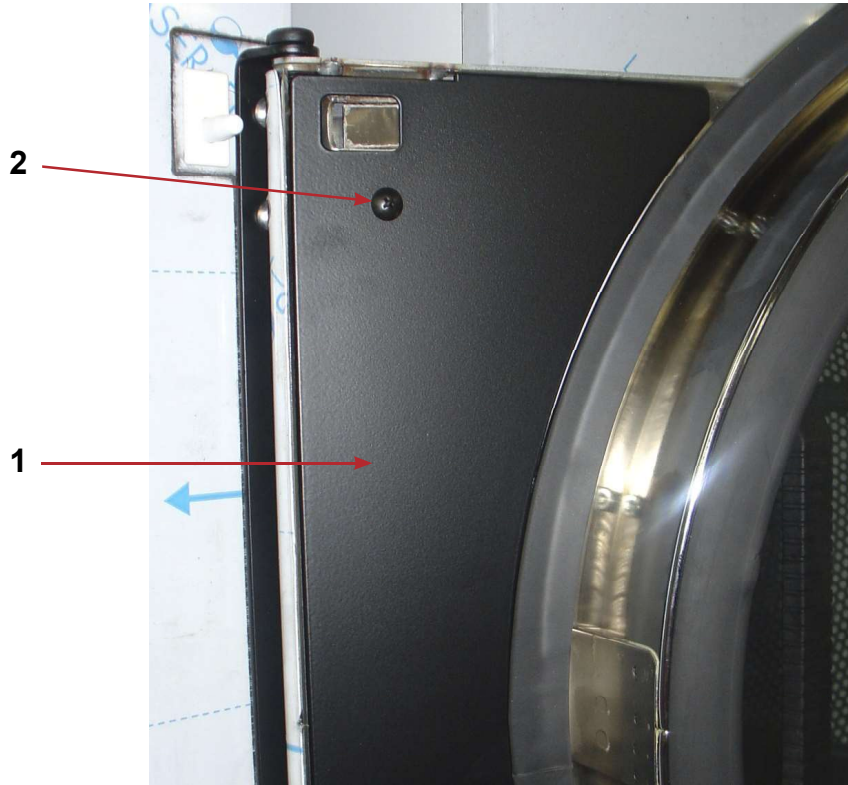

Door Switch Group

Part Number	Description	Quantity
9539-487-001	Door Switches	2



Bearing Housing Group

Key	Part Number	Description	Quantity
*	9803-160-003	Bearing Housing Complete Assy (Includes bearings & Spacer).....	1
1	9241-161-002	Housing, Bearing.....	1
*	9036-130-001	Bearing, Ball, Front	1
*	9538-139-002	Spacer, Bearing	1
2	9036-130-001	Bearing, Ball, Rear	1
3	9545-049-002	Screw-Wizlock, 3/8-24x3/4	4
4	8640-400-002	Nut, 5/16-18.....	4
5	9545-049-001	Screw, 3/8-24x1.....	2
6	8640-415-002	Nut, 3/8-24.....	2
*	9538-139-002	Shim, Tumbler	AR

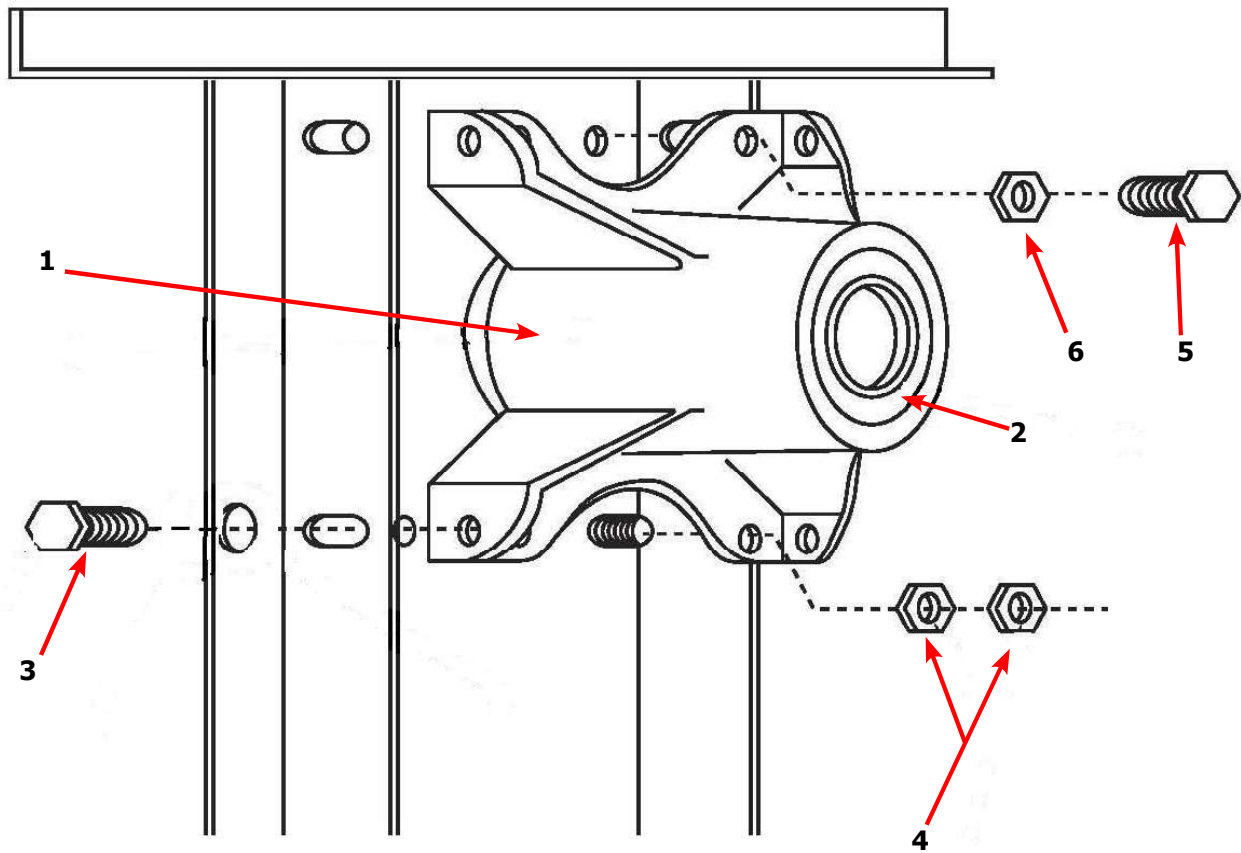

Tumbler Group

Key	Part Number	Description	Quantity
*	9848-147-001	Tumbler Assy Complete W/Spider (GALV).....	1
*	9848-142-002	Tumbler Assy Complete W/Spider (SS & Galv front).....	1
1	9848-146-001	Tumbler Assy (Galvanized).....	1
1	9848-146-002	Tumbler Assy (Stainless Galvanized front).....	1
2	9497-019-003	Rod, Tumbler.....	3
3	8641-554-001	Washer, Special.....	3
4	9552-013-000	Shim.....	AR
5	9568-015-001	Spider Assy.....	1
6	8640-415-004	Nut, Wiz Lock.....	3
7	9538-164-002	Spacer-Shaft.....	1
8	9487-234-005	Tolerance Ring.....	1
9	9908-049-002	Pulley, Driven.....	1
10	8641-581-026	Washer -Flat.....	1
11	8641-582-016	LockWasher - IntTooth, 1".....	1
12	9545-017-009	Screw, 1/2-13x1 1/4.....	1

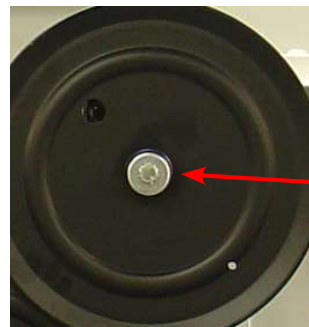
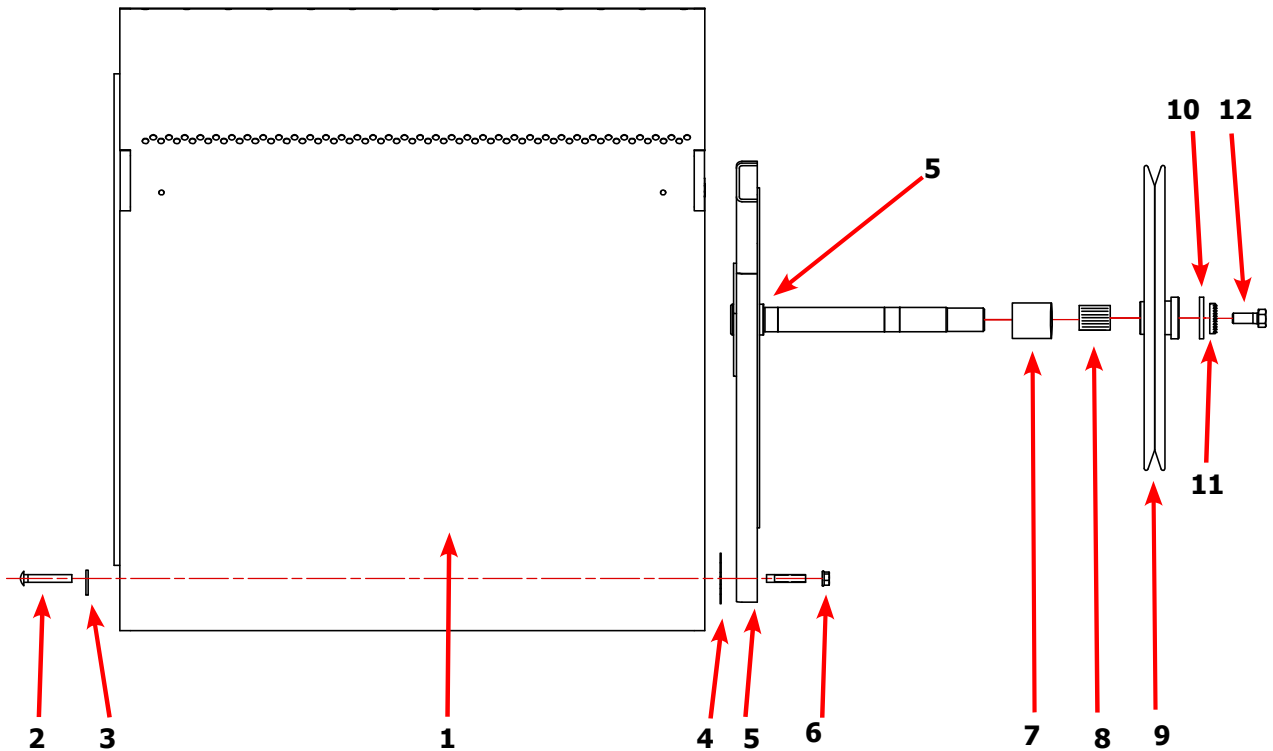

Burner Housing Group

Key	Part Number	Description	Quantity
*	9803-220-001	Housing Assembly, Burner (1 thru 7)	2
1	9454-831-001	Panel-Burner Front & Bottom	2
2	9454-826-001	Panel-Burner, Side LH	2
3	9454-790-001	Panel-Burner, Side RH	2
4	9049-080-001	Baffle-Burner	2
5	9454-791-001	Panel-Burner, Top	2
6	9074-307-001	Cover-Burner, Top	2
7	9828-015-001	Connector Assembly-Burner	2
*	9545-008-001	Screws-#10B X 1/4	8
*	9545-008-006	Screws-#10AB x 3/8	46
8	9452-729-001	Service Plate baffle Recirculation Chamber Clean Out	2
9	9545-008-001	Screw-#10B X 1/4	16
10	9003-220-001	Angle, Burner Support	2
11	9048-020-001	Burner, Main	4
*	9545-008-001	Screw 10B x1/4"	8
12	9452-991-001	Service Burner Plate Front (New style)	2
13	9545-008-001	Screw 10B x1/4"	8
14	9029-192-001	Bracket-High Limit	2
*	9538-142-001	Spacer, Hi-Limit	4
*	9545-045-007	Screw 8B x 3/4"	4
15	9576-203-002	Thermostat, Hi-Limit	13
16	9074-336-001	Cover, Hi-Limit Stat	
17	9875-002-003	Electrode Assy, Ignition	2
*	9545-045-001	Screw, Electrode Mtg 8B x 1/4"	4
18	9857-134-001	Control Assy, Gas, Honeywell	2
18	9857-192-001	Control Assy, Gas, White Rodgers (after Serial D1.19217.025)	2
19	9381-012-001	Manifold, Assy	2
*	9425-069-023	Orifice, Burner-Natural #125	4
*	9425-069-024	Orifice, Burner-LP #49	4
20	9029-175-001	Bracket, Manifold	2
21	8615-104-038	Pipe Plug in end of Burner Manifold	2
22	9576-207-008	Thermostat, Safety Shutoff	2
*	9545-008-006	Screw	4
23	9825-061-001	Cover, Safety Stat	2
*	9732-102-011	Kit, LP Conversion Honeywell Kit	2
*	9732-102-044	Kit, LP Conversion White Rogers Kit	2
*	8665-073-045	Nipple 1/2" x 2 Black	2
24	9838-018-001	Welded One Piece Gas Pipe Assembly	1
25	9379-196-001	Valve, Gas Shut Off (Optional)	1
26	9452-730-001	Burner tube service plate (Old Style Burner)	2

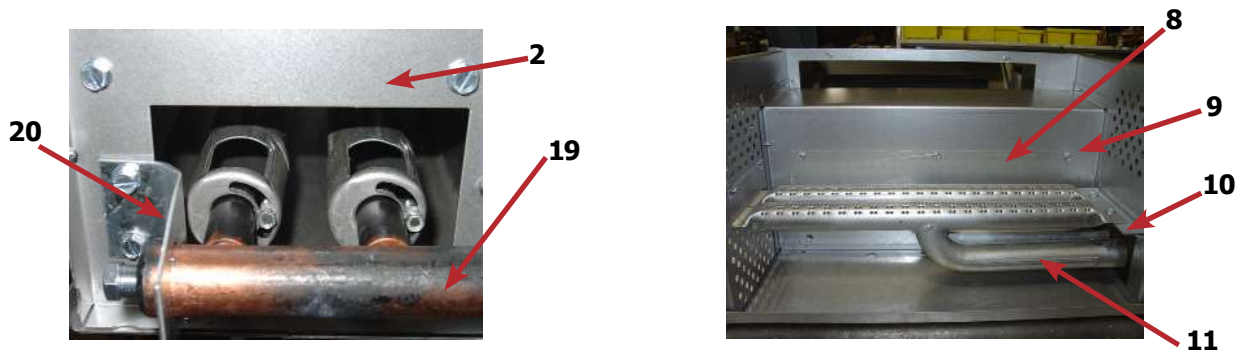

Burner Housing Group Photos

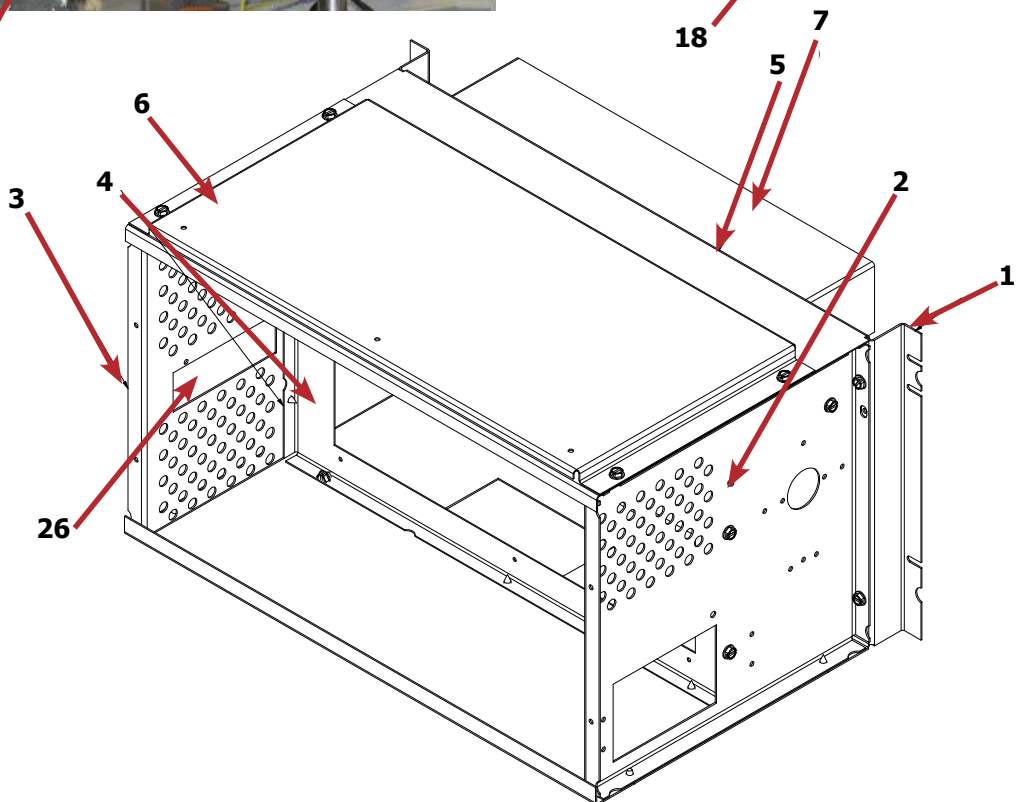
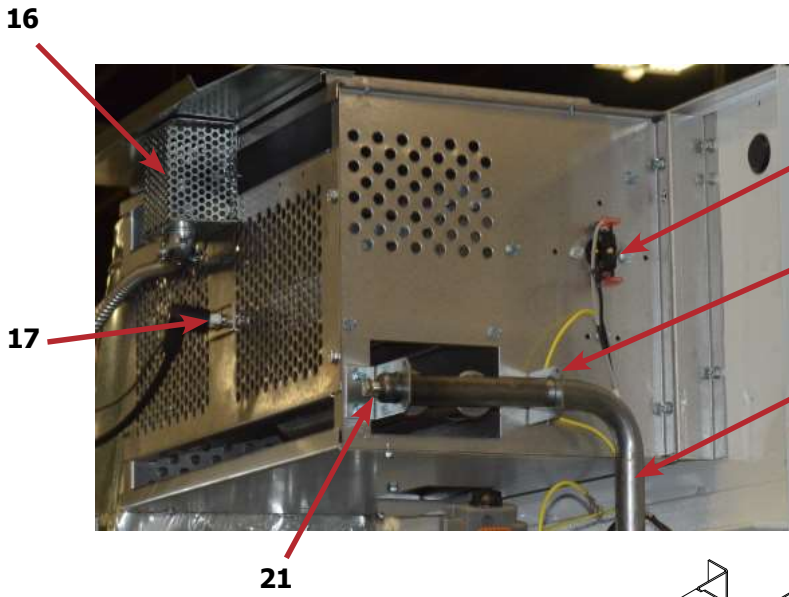
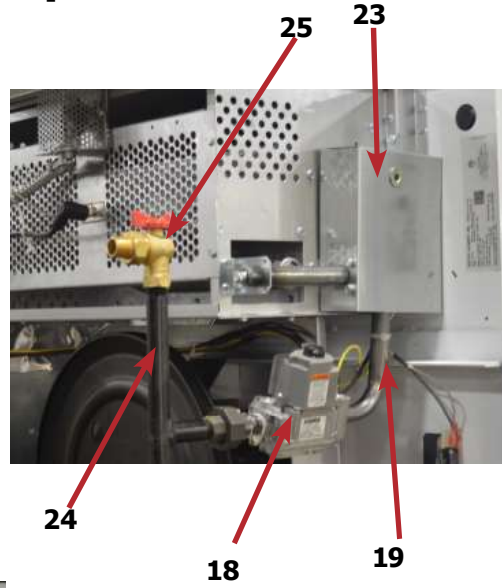
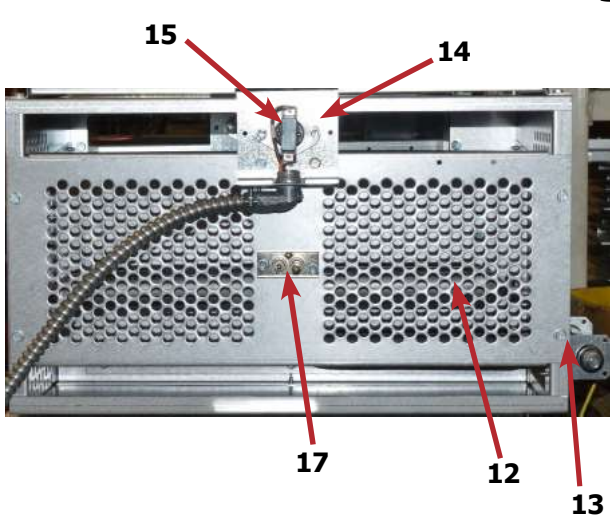

Rear View

Key	Part Number	Description	Quantity
*	9627-861-001	Wire Harness Overtemperature Switch	2
*	9801-095-001	Switch Assy, Air Flow	2
1	9539-461-009	Switch, Air Flow	2
2	9029-174-001	Bracket, Switch- Air Flow	2
3	9008-007-001	Actuator, Switch.....	2
4	9451-169-002	Pin, Cotter.....	2
5	9545-020-001	Screw 4-40 x 5/8".....	4
*	8640-401-001	Nut, Special Twin .#4-40	2
*	9550-169-003	Shield, Switch.....	2
*	9545-008-001	Screw 10 Bx 1/4"	6
*	9732-205-026	Motor Kit, Blower back, Belt	2
7	9376-331-001	Motor, Drive (Marathon)	2
8	9452-740-001	Plate, Motor Mtg	2
*	9545-029-008	Bolt 3/8" - 16 x 3/4".....	8
*	8641-582-003	Lockwash Spring 3/8.....	8
9	9545-018-019	Screw, Motor Plate to Back Assy. 1/4-20x 2 1/2.....	8
9	86411-582-007	Lockwasher 1/4	8
9	9538-,163-006	Spacer	8
9	8641-581-017	Flat Washer 1/4 x 7/8.....	
9	9209-086-002	Rubber Grommet	8
*	9538-166-006	Grommet Spacers	8
27	9453-157-001	Pulley, Motor	2
*	9545-028-013	Screw, Set.....	4
10	9962-017-002	Back Assy, Blower Hsg	2
26	9278-040-001	Impeller, W/Set Screws	2
11	9991-053-001	SupportAssy, Intermed. Pulley.....	2
12	9545-029-010	Bolt, Rd Hd 3/8-16 x 1 1/4	6
13	9545-029-003	Bolt, 3/8-16 x 1 1/2	2
12	8640-415-004	Nut Flange Wizioc 3/8" - 16.....	6
12	8641-581-035	Washer, Flat	6
14	9861-022-001	Arm Assy-Tension, Complete.....	2
*	8641-581-035	Washer, Flat	2
15	9487-200-003	Ring-Retaining	6
16	9908-039-004	Pulley Assy, Intermediate with bronze flange bearing.....	2
*	9036-145-002	Bearing - Bronze Flange	4
*	9538-164-002	Spacer-Shaft (See Tumbler Group for Expandrd View)	1
*	9487-234-005	Tolerance Ring.....	1
17	9908-049-002	Pulley, Driven	1
18	8641-581-026	Washer -Flat.....	1
18	8641-582-016	LockWasher - IntTooth, 1".....	1
18	9545-017-009	Screw, 1/2-13x1 1/4	1
19	9040-077-001	Belt, Drive- Motor	2
20	9040-073-009	Belt, Drive- Tumbler	2
21	9534-319-002	Spring, Tension.....	2
22	9099-012-002	Chain, Tension	2
23	9248-,022-002	Hook, Tension	2
*	9125-005-001	Damper Inside Duct Exhaust	2
24	9451-146-001	Pin, Damper Hinge.....	2
*	8520-141-000	Nut, Spring.....	4
*	9545-008-026	Screw #10B x 1/2	6
25	9825-059-001	Cover Duct Upper	1
*	9074-314-001	Cover Duct Lower	1
*	9545-008-024	Screw 10ABx 3/8".....	80
25	9973-030-001	Heat Recirculation Assembly Duct	2
27	9453-157-001	Motor Pulley - Driver	1
*	9029-173-001	Bracket for Wire Harness Under Burner Housing	2

Rear View Photos

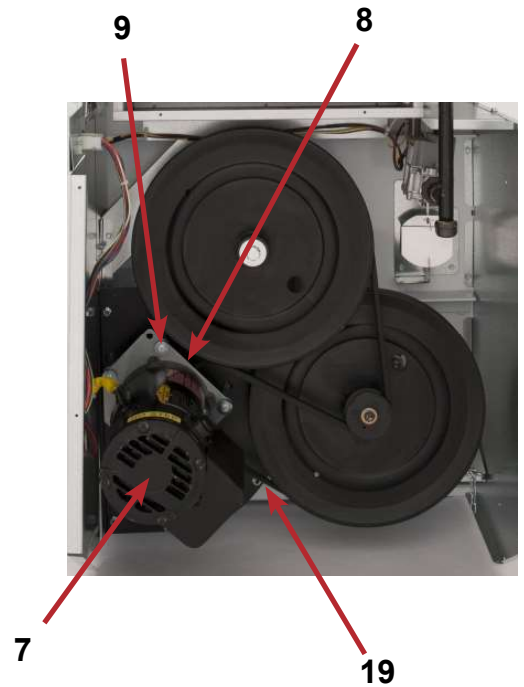
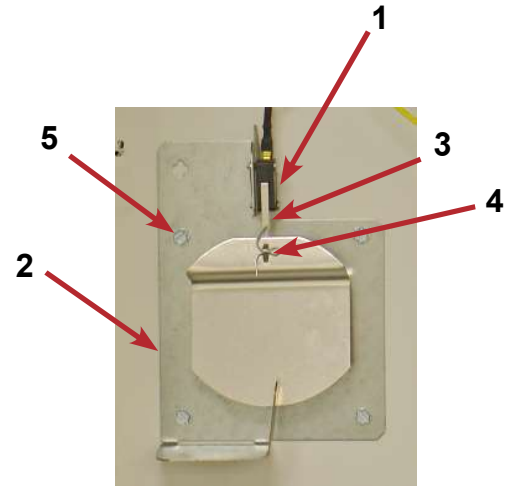
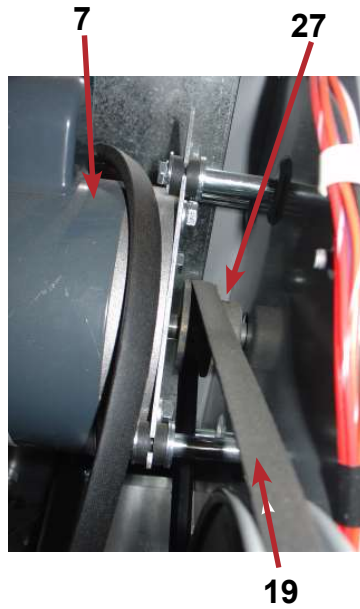
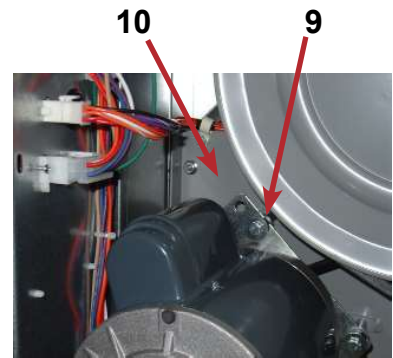
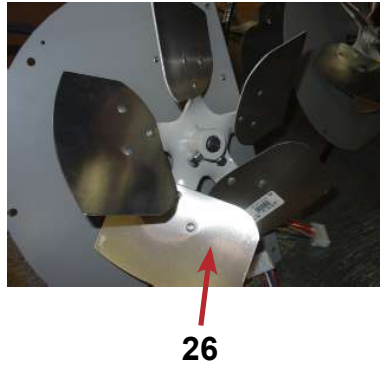
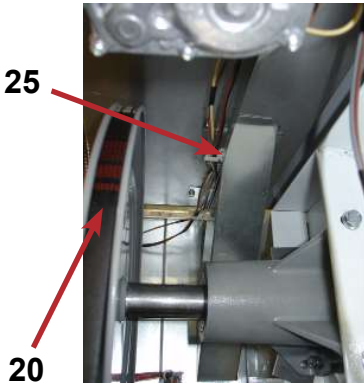

Rear Panel & Cover Group

Key	Part Number	Description	Quantity
1	9208-124-001	Back Drive Guard Panel.....	2
2	9208-123-001	Back Side Guard Panel	2
*	9545-008-024	Screw, Guards.....	*
*	9074-365-001	Cabinet (TOP COVER)	1
*	8544-006-001	Legs Leveling.....	4
4	9108-117-001	Electric Box Cover	6
5	9545-008-024	Screws 10 AB x 3/8	4
6	9109-113-001	Top Duct w/ Round	1
7	9074-319-001	Lower Duct Cover / Board.....	1

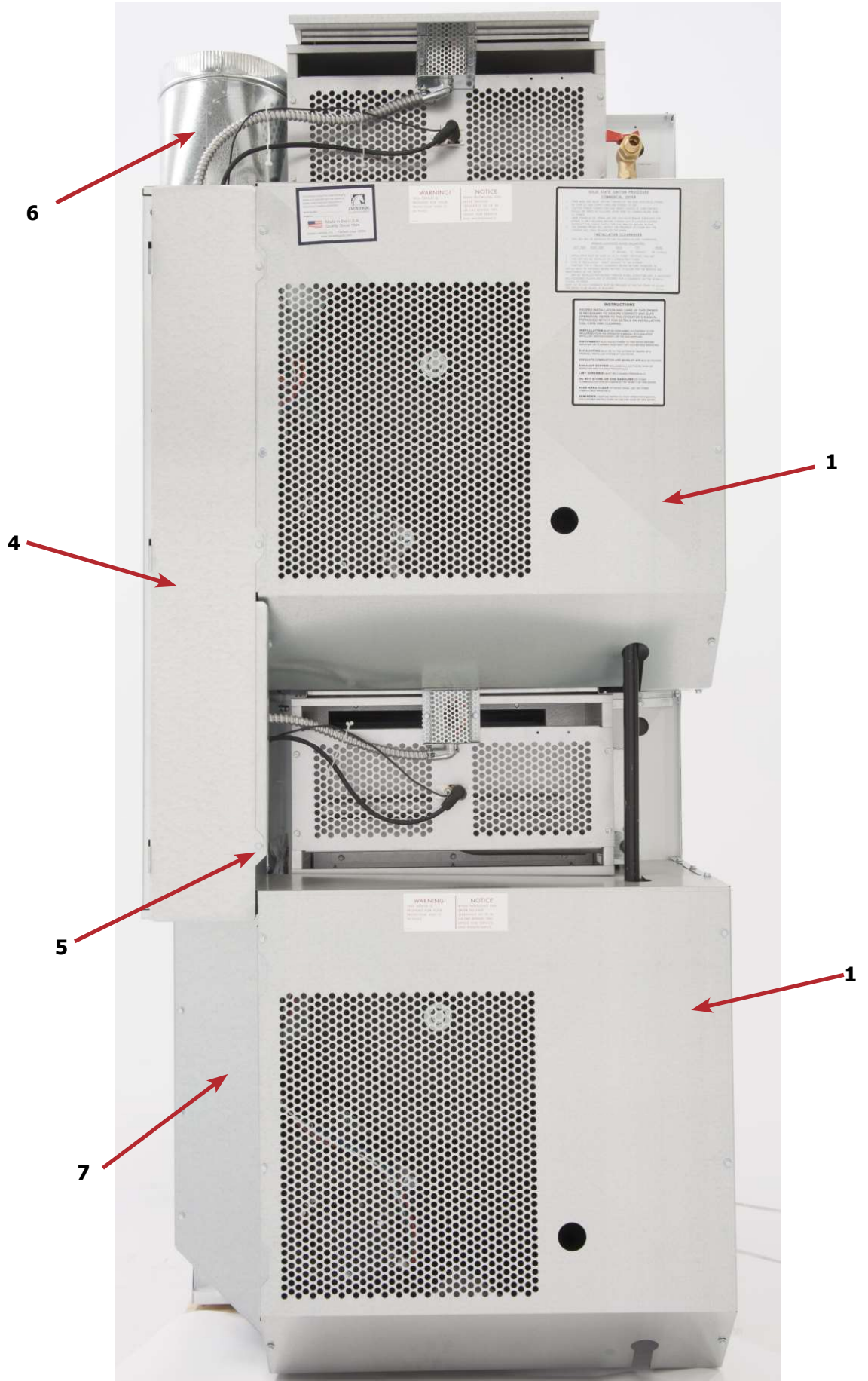

Control Assembly Group

Key	Part Number	Description	Quantity
*	9857-169-011	Control Assmby Complete (all below included)	1
*	9074-317-001	Control Box Cover	1
1	8653-068-003	Connector Conduit 3/8" STR.....	1
2	9558-031-001	Strip Terminal Marker (Behind Input Power) to above #3.....	1
3	9897-035-001	Terminal Block Assembly Main Power Inlet	1
*	9545-008-024	Screws 10AB x 3/8"	4
*	9627-859-003	Wire Harness - Power Main	1
4	8220-001-478	Wire Assembly Green 7"	1
5	9545-008-027	Screw # 10-32 x 12 Green	1
*	8641-582-006	Lockwasher Ext Tooth #10.....	1
6	9897-026-002	Terminal Block Main Power Middle	1
7	9897-026-001	Terminal Block.....	2
*	9545-045-012	Screw #8 ABx1 2 for terminal block.....	6
8	8711-013-001	Transformer Control.....	1
*	9545-008-024	Screws 10AB x 3/8"	4
9	9857-182-001	Ignition Control	2
*	9545-008-018	Screws 10AB x 3/4"	4
10	9631-403-009	Wire Assembly High Voltage Upper.....	1
11	9627-867-005	Wire Harness Ignition Control Upper.....	I
12	9631-403-008	Wire Assembly High Voltage Lower.....	1
13	9627-867-006	Wire Harness Ignition Control Lower.....	I
*	9053-067-002	Bushing Wire 7/8".....	4
14	9200-001-002	Fuseholder Assembly.....	3
*	8636-018-001	Fuse 1.5 Amp.....	2
*	8636-018-004	Fuee 2.5 Amp.....	1
15	5192-299-002	Relay Power.....	2
*	9545-045-012	Screws Power #8 AB x 1/2".....	4
*	8220-062-036	Wire Assembly Red/Black 14"	1
*	8220-062-037	Wire Assembly Red/White 14"	1
16	9627-864-006	Wire Harness Motor Extension.....	2
17	9527-007-001	Stand Off - Wire Saddle / Arrowhead	5
18	9627-863-001	Wire Harness Main Extension Access Under Burner Housing.....	4

Control Protection Fuse **14**
2.5 Amp

1

14

Ignition Upper Pocket
Protection Fuse 1.5 Amp

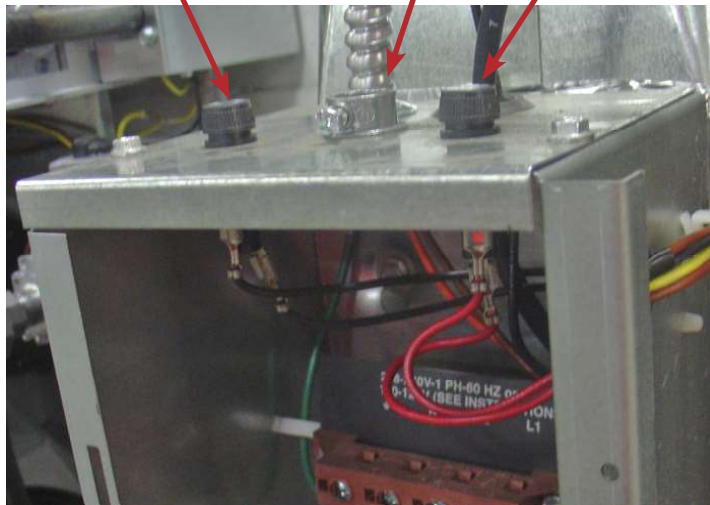

Not Shown:
24VAC Ignition Lower
Pocket Protection
Fuse

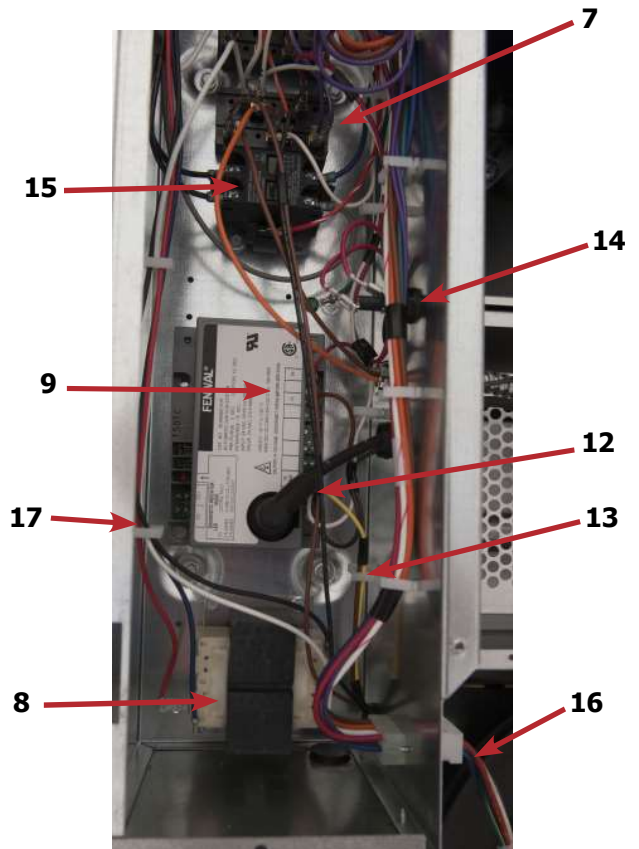
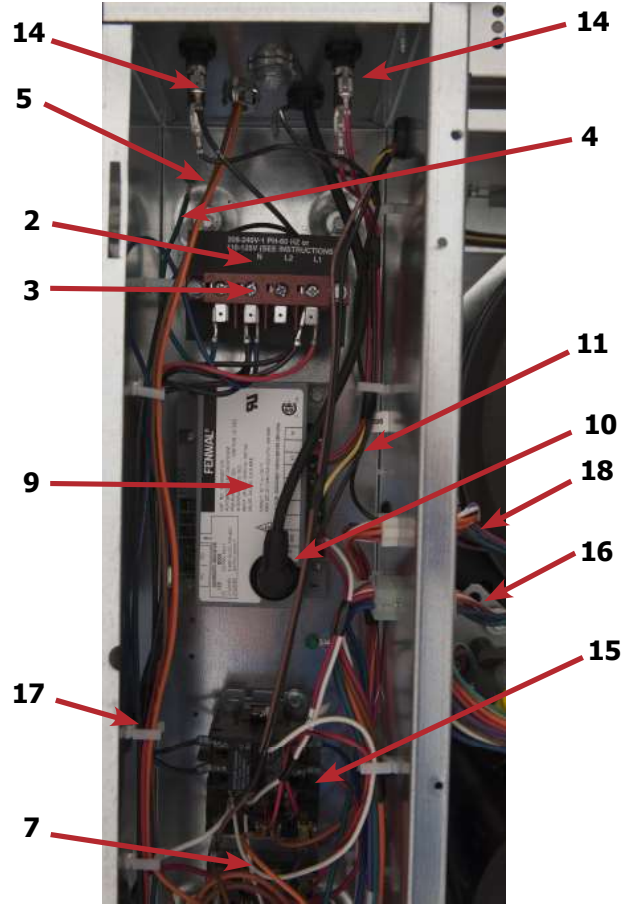
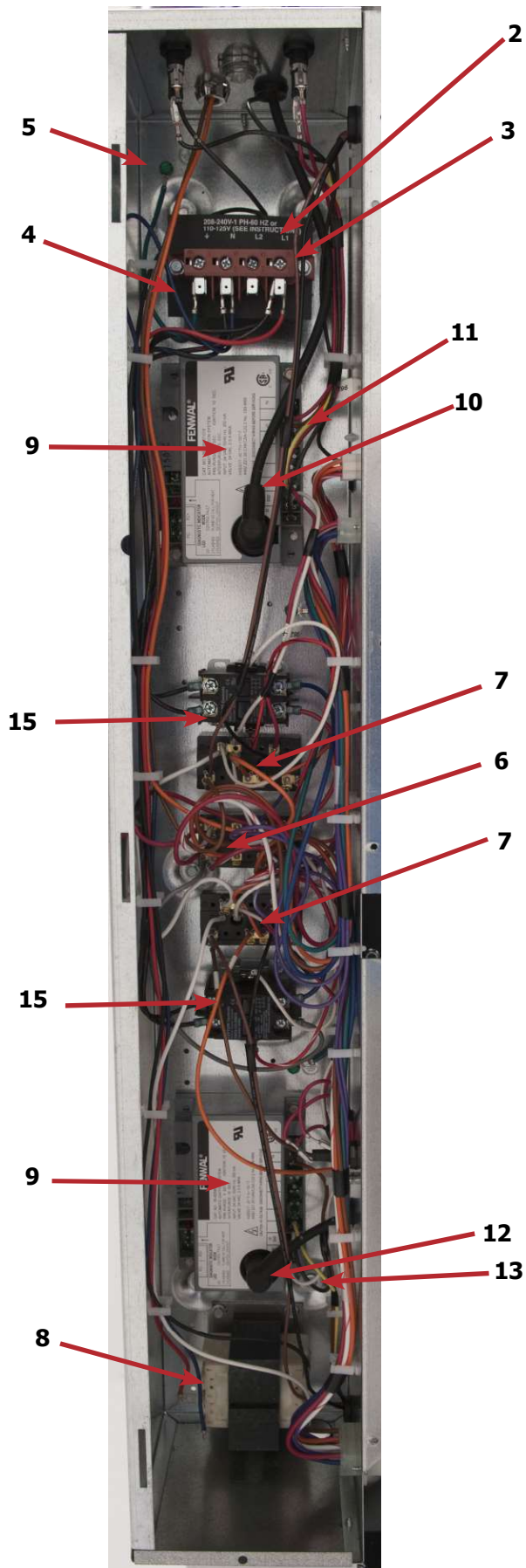

Coin Acceptor

Key	Part Number	Description	Quantity
1	9021-041-001	Coin Acceptor, Optical.....	1
2	9801-099-001	Sensor-Optical, Replacement.....	1
3	9545-039-002	Screw, Height Bar, 3mm.....	2
*	9486-136-001	Retainer, Coin Acceptor	1
*	9545-053-002	Screw	4

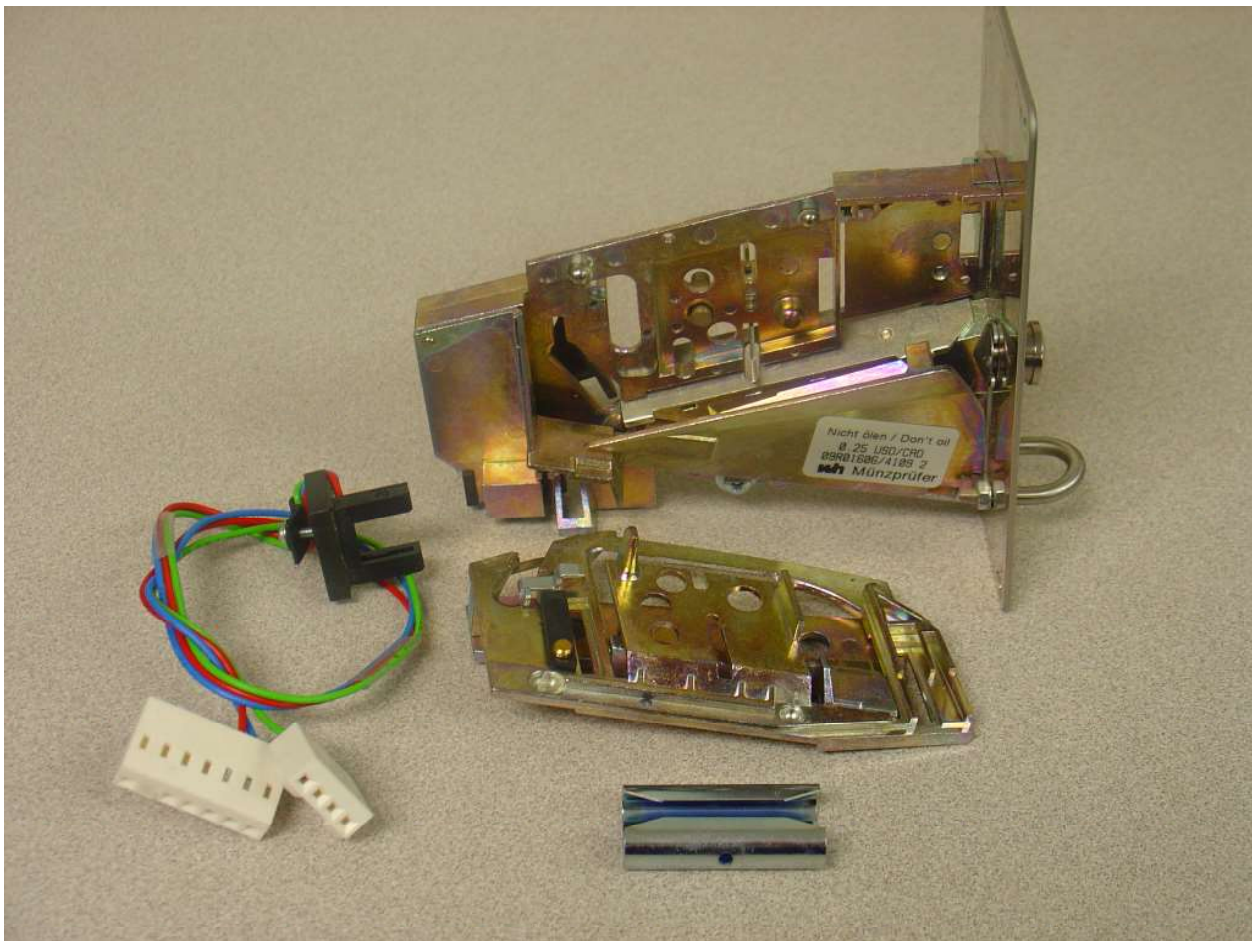

Wiring Group

Key	Part Number	Description	Quantity
*	9627-911-001	Wiring Harness- Main Power	1
*	9631-403-001	Wire, Hi Voltage, Spark 38".....	2
*	8502-645-001	Label Instruction.....	1
*	9506-544-001	Wiring Label Schematic/Diagram	1
*	9627-860-001	Wire Harness Ignition Upper Low Voltage	1
*	9627-860-002	Wire Harness Ignition Lower Low Voltage	1
*	9627-863-001	Wire Harness Main Extension	1
*	9627-864-001	Wire Harness Motor Extention	2
*	8220-062-036	Wire Assembly Red/Black 14".....	1
*	8220-062-037	Wire Assembly Red/White 14".....	1
*	8220-062-038	Wire Assembly White 14".....	2
*	9627-861-001	Wire Harness - Overtemp / Airswitch	2
*	9627-862-001	Wire Harness Main Controller w/ Door Switch Wires	1
*	9627-855-003	Wire Harness - Heat Sensor	1
*	8527-112-001	Decal Lighting and Clearance.....	1
*	8502-763-001	Label Warning & Notice	2
*	8502-764-001	Label Warning Dryer, FRN/SPN	2
*	9506-544-001	Schematic /Diagram.....	1
*	8514-233-001	Operators Manual	1
*	8507-365-001	Instructions Convert Dual Voltage	1
*	8507-330-001	Instruction Transient Voltage Suppressor	1
*	8507-350-001	Instructions Dryer Install / Start	1
*	8220-137-001	Wire Assembly Green 24".....	1
*	8220-001-466	Wire Assembly Yellow 4 7/8" Gas Valve	2
*	8220-095-038	Wire Assembly Orange 48".....	2
*	9506-544-001	Wiring Schematic/Diagram	1
*	8220-095-040	Wire Assembly Orange 24".....	1
*	8220-095-041	Wire Assembly Brown 24".....	1
*	9052-067-002	Bushings Wire 7/8".....	4

Wiring Diagram for DC30x2

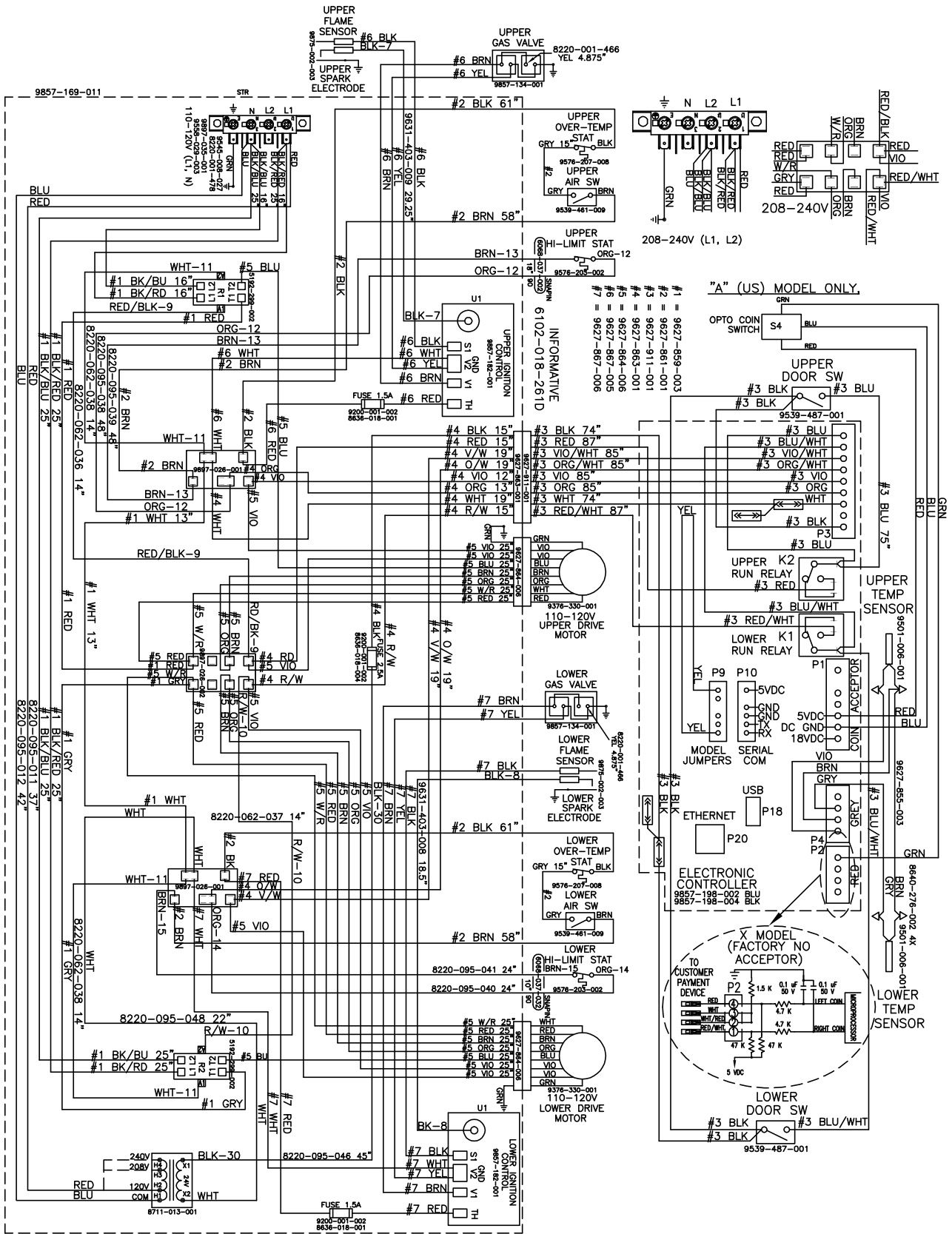

9506-595-001B WIRING DIAGRAM DC30X2NC-15EC2X-

Wiring Schematic for DC30x2

- NOTES:**
- DOOR SWITCHES ARE N.O. SWITCHES CLOSED WHEN DOOR IS CLOSED.
 - MOTOR RUN RELAY CONTACT WILL CLOSE WHEN THE COIN COUNT IS SATISFIED, THE DOOR CLOSED AND THE START BUTTON PRESSED.
 - REFER TO OWNERS MANUAL FOR DESCRIPTION OF OPERATION AND REQUIREMENTS FOR HEATING CIRCUIT.

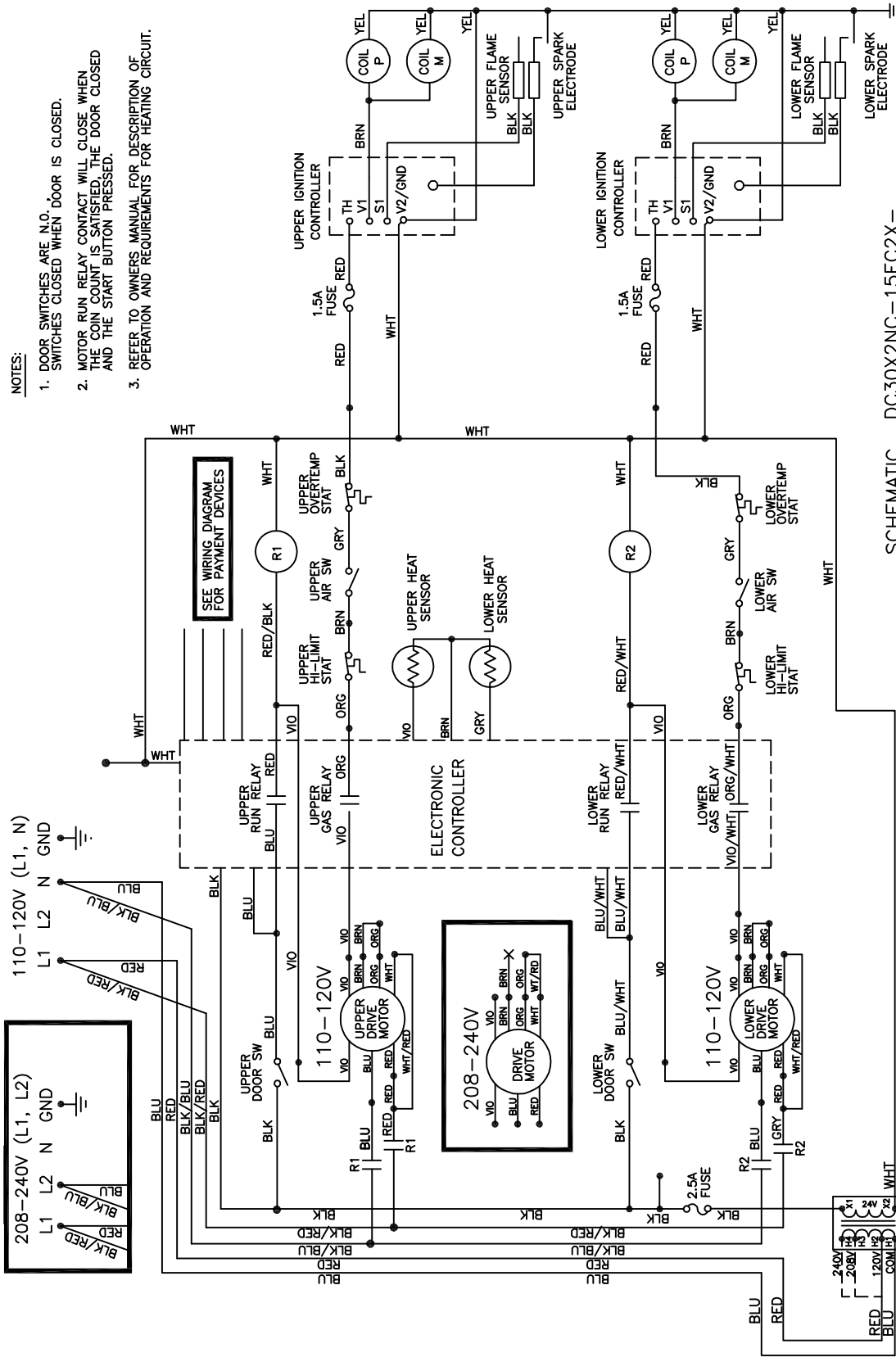

SCHEMATIC DC30X2NC-15EC2X-
9506-595-001 REV. B
110-120/208-240V, 1 PHASE, 60 HZ

IMPORTANT: RETAIN THIS ELECTRICAL SCHEMATIC FOR SERVICE.

