



# **55 Pound OPL Computer Dryer**

## **Parts and Service Manual**

For Electric, Gas & Steam Heated Models 50/60 Hz.

---

# Dexter Safety Guidelines

---



## **WARNING**

**The dryer must not be stored or installed where it will be exposed to water and/or weather.**

For your safety the information in this manual must be followed to minimize the risk of fire or explosion or to prevent property damage, personal injury or death. Do not store or use gasoline or other flammable vapors and liquids in the vicinity of this or any other appliance.

---

### **WHAT TO DO IF YOU SMELL GAS**

- Do not try to light any appliance.
- Do not touch any electrical switch: do not use any telephone in your building.
- Clear the room, building or area of all occupants.
- Immediately call your gas supplier from a neighbor's telephone.
- Follow the gas supplier's instructions.
- If you cannot reach your gas supplier, call the fire department. Installation and service must be performed by a qualified installer, service agency or the gas supplier.

---

***To activate your warranty, be sure to return your red warranty form to the factory. Please have serial number and model ready when calling for assistance.***

You, the purchaser, must post in a prominent location instructions to be followed in the event the user smells gas. Consult your local gas supplier for procedure to be followed if the odor of gas is present.

Post the following "For Your Safety" caution in a prominent location:

#### **FOR YOUR SAFETY**

Do not store or use gasoline or other flammable vapors or liquids in the vicinity of this or any other appliance.

#### **THIS MACHINE IS FOR DRYING ONLY FABRICS CLEANED IN WATER.**

To avoid possibility of fire, including spontaneous combustion, do not dry oiled floor mops, items containing foam rubber or similarly textured rubberlike materials or any material on which you have used a cleaning solvent or which contains flammable liquids or solids (such as gasoline, kerosene, waxes, etc.)



---

# Model DCWD55

w/ Microprocessor Control Gas Heat Source

## Capacity

Dry Weight Capacity	55 lbs	24.8 kg
Cylinder Diameter	32.5"	82.55 cm
Cylinder Depth	38"	96.52 cm
Cylinder Volume	18.2 cu ft	516.5 dm <sup>3</sup>

## Dimensions

Cabinet Height (with feet)- Minimum	72.25"	183.52 cm
Cabinet Height (with feet)- Maximum	73.25"	186.06 cm
Cabinet Width	34.4375"	87.47 cm
Overall Depth	51.125"	129.86 cm
Floor to Door Bottom	29.5"	74.93 cm
Door Opening	22.6875"	57.63 cm

## Electrical

Electrical Phase	Single
Electrical Voltage (60 Hz)	120 V
Electrical Running Amps (60 Hz)	7.8
Circuit Protection (60 Hz)	15 AMP
Electrical Wire Size	12 Gauge
Electrical Service (Single Phase)	2 wire + ground
Motor Size	3/4 HP .56 kW
Tumble Direction	Counter Clockwise
Tumble Speed	47 RPM

## Gas Heat

Gas Input/Hour	160,000 BTU	,320 kcal
Gas Supply Connection (NPT)	1/2"	12.7 mm
Natural Gas Supply (Water Column)	5 -10"	12.7 - 25.4 cm
L.P. Supply (Water Column)	11.0 -13.5"	27.9 - 34.29 cm

## Installation

Air Flow	910 CFM	25.77 M <sup>3</sup> /min
Exhaust Size (Vent Diameter)	8"	20.32 cm
Make-Up Air (Minimum)	1.25 ft <sup>2</sup>	.12 m <sup>2</sup>
Net Weight	581 lbs	262 kg
Clearance Behind Machines (Minimum)	18"	45.72 cm

---

# **Section 2:**

## **Installation & Operation**

---

## Section 2: Uncrating, Installation & Operation

Remove cardboard and innerpack.

### Installation

All commercial dryer installations must conform with local applicable local codes or in the absence of local codes, with the National Fuel Gas Code ANSI Z223.1A-1988. Canadian installations must comply with current standard CAN/CGA-B149(.1 or .2) Installation Code for Gas Burning Appliances or Equipment, and local codes if applicable. The appliance, when installed, must be electrically grounded in accordance with the National Electric Code, ANSI/NFPA No. 70-1990, or when installed in Canada, with Standard CSA C22.1 Canadian Electrical Code Part 1.

### Installation Clearances

This unit may be installed at the following alcove clearances.

1. Left side            0"

2. Right side           0"

\*Units may be installed in direct contact with an adjacent dryer, providing allowance is made for opening upper & lower service doors.

3. Back 18" (certified for 1" clearance; however 18" behind the guard is recommended to clean, service & maintain the dryer)

4. Front 48" to allow use of dryer.

5. Top Certification allows 0" clearance at the top from the front back 1". However, a 1/2" clearance is required to allow opening the upper service door. A 4" clearance is required at the top between 1" & 4" from the front. A 10" clearance is required from the top at all other points.

6. Floor. This unit may be installed upon a combustible floor.

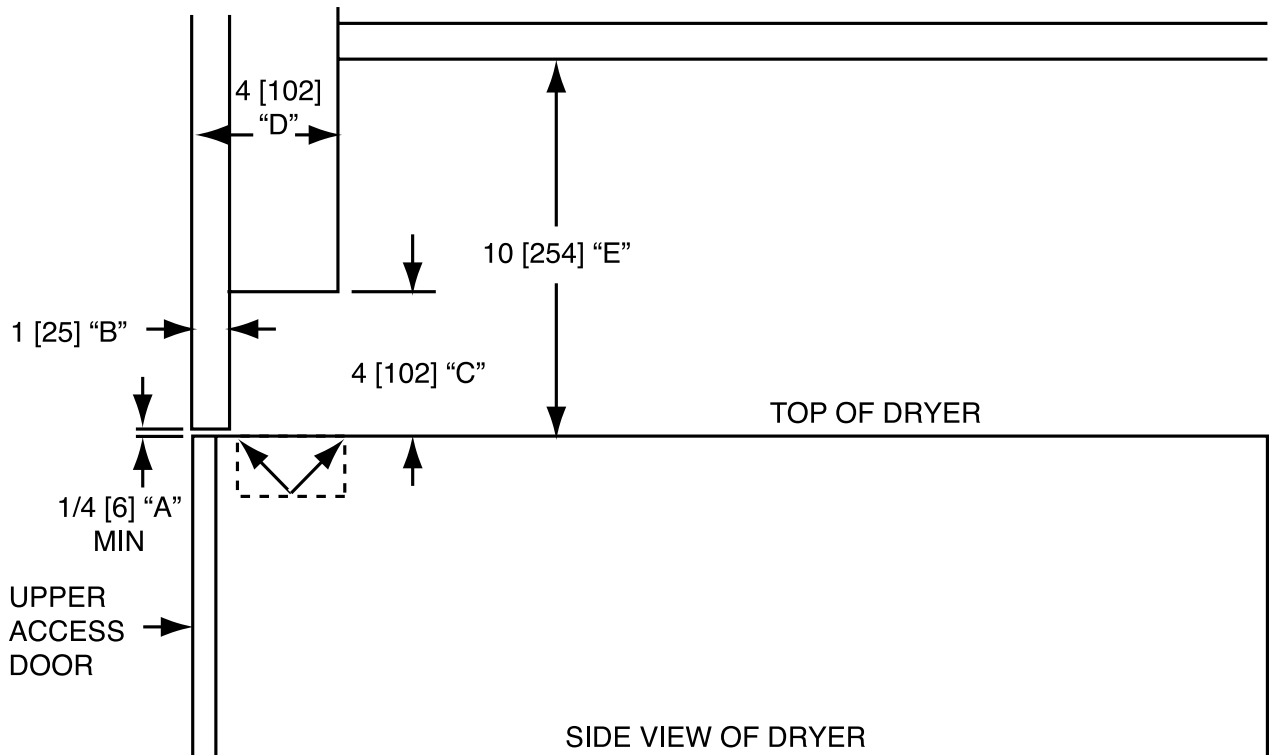

## Vertical Clearance Dimensions

Inches [MM]

### Make-up Air

Adequate make-up air (910 CFM) (26 m<sup>3</sup>/Min.) must be supplied to replace air exhausted by dryers on all types of installations. Provide a minimum of 1.25 sq. ft. (.12 m<sup>2</sup>) make-up air opening to the outside of each dryer. This is a net requirement of effective area. Screens, grills or louvers which will restrict the flow of air must be considered. Consult the supplier to determine the free area equivalent for the grill being used.

The source of make-up air should be located sufficiently away from the dryers to allow an even air flow to the air intakes of all dryers. Multiple openings should be provided.

**NOTE:** The following considerations must be observed for gas dryer installations where dry cleaners are installed. The sources of all make-up air and room ventilation air movement to all dryers must be located away from any dry cleaners. This is necessary so that solvent vapors will not be drawn into the dryer inlet ducts. Dry cleaner solvent vapors will decompose in contact with an open flame such as the gas flame present in clothes dryers. The decomposition products are highly corrosive and will cause damage to the dryer ducts and clothes loads.

---

## Electrical Requirements For Gas Heated Models

The electrical requirements necessary to operate the unit satisfactorily are listed on the serial plate located on the back panel of each dryer. The electrical connection should be made to the control box on the rear of the unit, using #12 AWG wire or larger. ONE 15 Amp circuit breaker is required. The wiring diagram is located on the belt guard on the back of the dryer.

**NOTE:** The dryer must be grounded by a separate ground conductor from the ground screw on the dryer to the neutral bar in the supply breaker box.

## Electrical Requirements For Electric Heated Models

*The electrical installation must be performed by a qualified electrical technician.*

The electrical power requirements necessary to operate the unit satisfactorily are listed on the serial plate located on the back panel of each dryer. The electrical connection should be made at the terminal blocks in the control box on the rear of the unit using conductors rated at 75 C (167 F) and a wire size adequate to handle the amperage and voltage listed on the serial plate (see table on the next page for recommended minimum sizes). It is absolutely necessary that the dryer be grounded to a known (earth) ground (No. 8 AWG copper conductor recommended). A 1/4 inch pilot hole is provided to locate the opening for the connection of the conduit for the power supply conductors. A hole is provided for the connection of a 3/8 inch conduit for the external grounding conductor.

HEATING ELEMENT SIZE (kW)	SUPPLY VOLTAGE (PHASE / V.)	MINIMUM DUAL ELEMENT TIME DELAY FUSE SIZE AT FUSED DISCONNECT (A.)	MINIMUM WIRE SIZE FROM FUSED DISCONNECT TO DRYER TERMINAL BLOCK (75OC COPPER WIRE)
24	3 / 400	50	# 6
30	3 / 400	60	# 4
36	3 / 400	80	# 3

The installation must meet the electrical requirements of the country, state and locality of the installation. The installer may be required to provide a disconnect switch which will interrupt all lines. It may be a local or national requirement to provide an electrical interruption switch visible and accessible from the room in which the dryer is installed. The wiring diagram is located on the belt guard on the back of the dryer.

## MISE À LA TERRE

Cet appareil doit être relié à une canalisation électrique métallique fixe ou la dérivation doit comporter un conducteur de terre connecté à la borne ou au fil de terre de l'appareil.

## Gas Requirements

The complete gas requirements necessary to operate the dryer satisfactorily are listed on the serial plate located on the back panel of the dryer. The inlet gas connection to the unit is ½ inch pipe thread. However, the size of the piping to supply the dryer should be determined by reference to the Fuel Gas Code and consulting the local gas supplier.



A joint compound resistant to the action of liquefied petroleum gases should be employed in making pipe connections. A 1/8 inch NPT plugged tapping, accessible for test gage connection, must be installed immediately upstream of the gas supply connection to the dryer. A drip tee should be provided in the gas piping supplying the unit to catch dirt and other foreign articles. All pipe connections should be checked for leakage with soap solution or leak detector. Never check with an open flame.

## Exhaust Installation

An 8" diameter exhaust connection is required. Exhausting of the dryer(s) should be planned and constructed so that no air restrictions occur. Any restriction due to pipe size or type of installation can cause slow drying time, excessive heat, and lint in the room.

From an operational standpoint, incorrect or inadequate exhausting can cause a cycling of the high limit thermostat which shuts off the main heaters and results in inefficient drying.

Individual exhausting of the dryers is recommended. All heat, moisture, and lint should be exhausted outside by attaching a pipe of the proper diameter to the dryer adapter collar and extending it out through an outside wall. This pipe must be very smooth on the inside, as rough surfaces tend to collect lint which will eventually clog the duct and prevent the dryer from exhausting properly. All elbows must be smooth on the inside. All joints must be made so the exhaust end of one pipe is inside the next one downstream. The addition of an exhaust pipe tends to reduce the amount of air the blower can exhaust. This does not affect the dryer operation if held within practical limits. For the most efficient operation, it is recommended that no more than 20 ft. (6 m) of straight 8 in. (204 mm) diameter pipe be used with two right angle elbows. When more than two elbows are used, 2 ft. (610 mm) of straight pipe should be removed for each additional elbow. No more than four right angle elbows should be used to exhaust a dryer.

If the exhaust pipe passes through a wall, a metal sleeve of slightly larger diameter should be set in the wall and the exhaust pipe passed through this sleeve. This practice is required by some local codes and is recommended in all cases to protect the wall. This type of installation should have a means provided to prevent rain and high winds from entering the exhaust when the dryer is not in use. A hood with a hinged damper can be used for this purpose. Another method would be to point the outlet end of the pipe downward to prevent entrance of wind and rain. In either case, the outlet should be kept clear, by at least 24 in. (610 mm), of any objects which would cause air restriction.

Provide a screen or grill over the termination of the exhaust or flue outlet such as will prevent the entry of a ball of 16 mm in diameter while the machine is not operating but will allow entry of a ball 6 mm in diameter while operating.

When exhausting a dryer straight up through a roof, the overall length of the duct has the same limits as exhausting through a wall. A rain cap must be placed on top of the exhaust and must be of such a type as to be free from clogging. The type using a cone shaped "roof" over the pipe is suitable for this application.

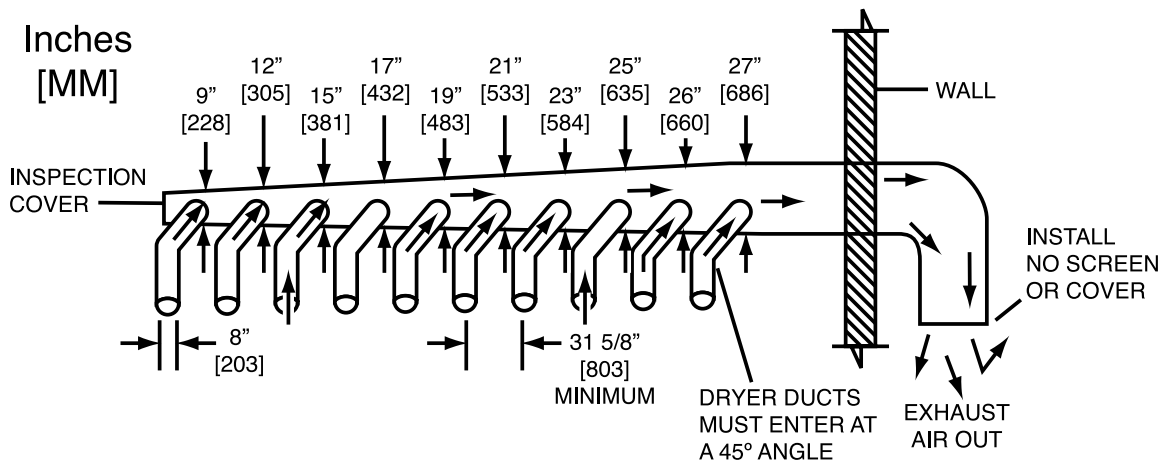

---

Exhausting the dryer into a chimney or under a building is not permitted. The exhaust air should not be vented into a wall, a ceiling, or a concealed space of building. In these cases there is a danger of lint buildup which can be highly combustible.

Installation of several dryers, where a main discharge duct is necessary, will need the following considerations for installation (see Figure 2). Individual ducts from the dryers into the main discharge duct should be at a 45 degree angle in the direction of discharge air flow.

**NOTE:** Never install the individual ducts at a right angle into the main discharge duct. The individual ducts from the dryers can enter at the sides or bottom of the main Discharge duct. Figure 2 indicates the various round main duct diameters to use with the individual dryer ducts. The main duct can be rectangular or round, provided adequate air flow is maintained. For each individual dryer, the total exhausting (main discharge duct plus duct outlet from the dryer) should not exceed the equivalent of 20 ft. (6 m) and two elbows. The diameter of the main discharge duct at the last dryer must be maintained to exhaust end.

**NOTE:** A small diameter duct will restrict air flow; a large diameter duct will reduce air velocity - both contributing to lint build up. An inspection door should be provided for periodic clean-out of the main duct.

**CAUTION:** A clothes dryer produces combustible lint and should be exhausted outdoors. The area around the clothes dryer should be kept free of lint.

## Dryer Shutdown

To render the dryer inoperative, disconnect electrical supply to the dryer.

## Electrical Requirements

(Refer to schematic and wiring diagram). The main voltage is 120V, 60 Hz. The electrical power requirements necessary to operate the unit satisfactorily are listed on the serial plate located on the back panel of each dryer. The electrical connection should be made to the terminal in the control box on the rear of the unit, using a wire size adequate to handle the amperage and voltage listed on the serial plate, but never smaller than No. 12 AWG wire. The ground lug must be connected to a good external ground. Individual circuit breakers for each unit are recommended. The schematic and wiring diagram are located on the belt guard on the back of the machine. The voltage is reduced to 24V for operating controls.

## Operating Mode -- Manual Dry Cycle

Place the clothes load to be dried in the cylinder and close the dryer door. The clothes should be well separated. Untangling following washing may be necessary for proper drying. Enter the amount of drying time using the numbers. The Manual LED will light. Push the Start button.

When a cycle is running, the display will show the number of minutes that remain in the cycle. The dryer will switch to the Cool Down mode when the Manual Dry cycle is finished. The drying time depends on the size of the load, the type of clothes, the amount of water in the clothes, the room temperature and humidity. At the end of the Cool Down, the dryer will stop and the display will flash **DONE**.

If the clothes load is not removed, the dryer will automatically tumble every two minutes for twenty seconds to start. After twelve minutes, the time between tumbles is extended to ten minutes. The Wrinkle Free mode stops when the door is opened or the Clear button is pressed.

**CAUTION:** Damage can occur if any fabric, including 100% cotton is run for an extended period of time on a hot after the clothes are dry.

**IMPORTANT:** Clothes should be removed as soon as possible after the cycle is completed and the dryer is shut off, to prevent any excessive wrinkling.

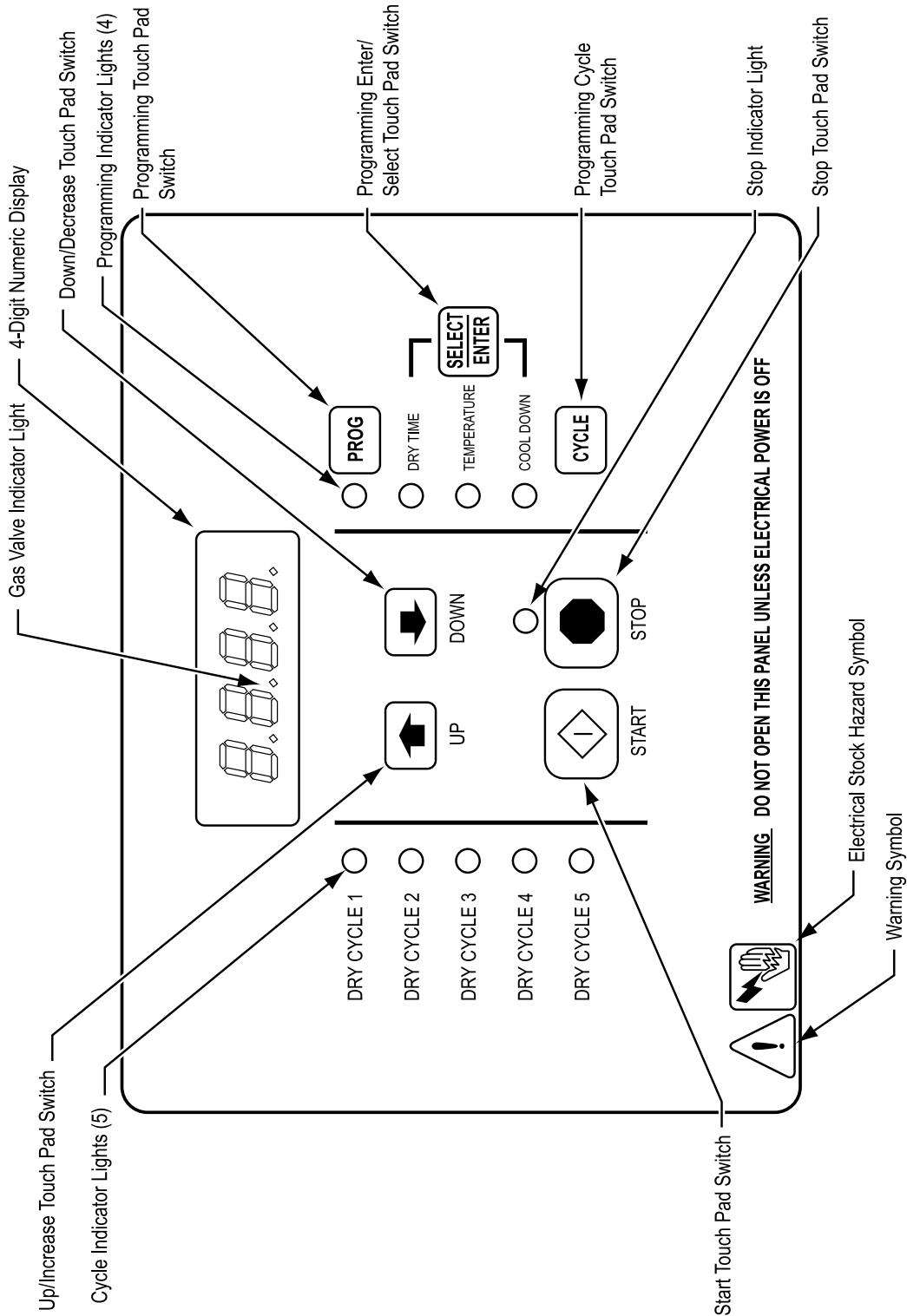

**Figure 3: Non-Reversing Dryer Controller Interface**

## Dryer Controller Factory Default Program Settings

DRY CYCLE	COOL DOWN TIME (MINUTES)	TOTAL CYCLE TIME (MINUTES)	DRYING TEMP (°F)	DRYING TEMP (°C)	DRYER LOAD
1	5	35	180	82	Towels, pads, heavy cotton
2	2	20	170	77	Sheets, blended materials
3	5	25	180	82	Cotton
4	2	20	130	54	Synthetic materials
5	2	25	175	79	Blended materials

## Dryer Fault Codes

FAULT#	FAULT DESCRIPTION	ACTION
F1	Shorted thermostat sensor.	Dryer stops and "F1" flashes on the 4- digit display. When short circuit on sensor input is removed, "LOAD" appears on the 4-digit display and the remaining dry time is reset.
F2	Open thermostat sensor.	Dryer stops and "F2" flashes on the 4-digit display. When a good sensor is connected to sensor input, "LOAD" appears on the 4-digit display and the remaining dry time is reset.
F3	EEPROM corrupted.	Dryer will not start and "F3" appears on the 4-digit display. The power to the dryer must be cycled to reset the controller. Fault should only occur when starting a dry cycle.
F4	Gas valve on fault.	The drying temperature did not increase 1°F. in 5 minutes. "F4" will flash on the display and the dry cycle will finish without calling for heat (energizing gas valve). Opening the door or pressing the STOP key will reset the fault and clear the remaining time in the dry cycle.
F5	Temperature fault.	The drying temperature is at least 25°F. above the temperature setting. "F5" will flash on the 4-digit display and the dry cycle will finish without calling for heat (energizing the gas valve). The power to the dryer must be cycled to reset the controller.

## Touch Pad Description

<b>Indicator Lights (L.E.D.s)</b>	
Cycle	These L.E.D.s are on solid when a particular cycle is chosen for operation (1 through 5) or programming.
Gas Valve	This L.E.D. is part of the 4-digit numeric display and will be on solid during the drying part of a cycle when the gas valve does <u>not</u> need to be on. The L.E.D. will be blinking when the gas valve needs to be on. The L.E.D. will <u>not</u> be on solid or blinking (off) if the cycle is stopped, complete, in cool down, or terminated.
Programming	These L.E.D.s are on solid as they are selected during the programming of the dryer controller.
Stop	This L.E.D. is on solid when either the STOP button is pressed once or the door is opened during an operating cycle.
<b>Switches (Pushbuttons)</b>	
Up/Increase	This touch pad switch will increment (increase) dry time, cool down time, and drying temperature. It will also scroll upwards when selecting a dry cycle.
Down/Decrease	This touch pad switch will decrement (decrease) dry time, cool down time and drying temperature. It will also scroll down when selecting a dry cycle.
Program	This touch pad switch allows the dryer controller to enter the permanent programming mode.
Select/Enter	This touch pad switch will select one of the three variable parts of the dry cycle (dry time, temperature, or cool down) by sequencing through them. Once one of the variable parts of the dry cycle is chosen and changed, this touch pad switch will enter the new value into the dry cycle program.
Cycle	This touch pad switch allows the dryer controller to enter the temporary programming mode.
Stop	This touch pad switch will stop the dryer during a dry cycle without clearing the present drying cycle if pressed once. If pressed and released twice, consecutively, the present dry cycle will be cleared.
Start	This touch pad switch will start the operation of a dry cycle if pressed and released once. Pressing <u>and holding</u> this touch pad switch will display the current temperature of the dryer heat sensor as long as it is held in the depressed position.

## 4-Digit Numerical Display Messages

Message	Description
LOAd	This message is displayed after a dry cycle is complete and the dryer loading door has been opened or the STOP touch pad key on the dryer controller has been pressed and released twice.
donE	This message blinks immediately after completion of the dry cycle and continues to blink until the stop key on the dryer controller touch pad is pressed or the dryer loading door is opened.
Prog	This message is displayed when entering the permanent programming mode.
.15	This message appears while the dryer is in the heating time of a dry cycle. The decimal point will blink if the output for the gas valve is on, or remain on constantly if the output for the gas valve is not on. The number represents the total time left in the dry cycle (includes cool down time).
C02	This message appears when the cool down time of the dry cycle is reached. The letter "C" represents the cool down (non-heating) part of the dry cycle. The number(s) after the letter "C" represent(s) the total time remaining in the dry cycle.
F5	This message appears if there is a dryer fault. The letter "F" indicates a fault and the number after the "F" represents the specific fault that has occurred. There are five different faults that can appear (F1 through F5).

---

# Operating Instructions

To dry a load of items, you must choose one of the five-programmed dry cycles. Each of these five dry cycles may be modified in two different ways to match your load. Please refer to the “Permanent Dryer Controller Programming” or “Temporary Dryer Controller Programming” section of this manual.

There are two parts to each dry cycle. The first part is the heating time, which is when the gas valve is cycled on and off according to the temperature setting in the dry cycle program. The second part is the cool down time, which is after the heating part of the dry cycle, and is when the cylinder continues to turn, but no heat is applied. There will always be at least two minutes of cool down time for each dry cycle. The maximum amount of cool down time is 15 minutes.

The five default dry cycle values are shown in the “DRYER CONTROLLER FACTORY DEFAULT PROGRAM SETTINGS” table in this manual. To improve the drying capabilities of this dryer, you should always separate (untangle) the individual articles in your load before using the dryer.

In the following instruction steps, things that are displayed on the 4-digit numerical display will be in “quotation marks” and any keys on the dryer controller touch pad that physically need to be pressed will be in CAPITAL AND BOLD LETTERS.

**STEP 1:** Place your untangled load into the dryer cylinder and close the dryer loading door. Notice that the dryer controller 4-digit numerical display should show the word “LOAD”. If it does not show this word, then press and release the STOP touch pad key on the dryer controller twice.

**STEP 2:** Press and release the UP or DOWN arrow touch pad key on the dryer controller to select a dry cycle.

**STEP 3:** Once the desired dry cycle is selected, press and release the START touch pad key.

After the dryer controller START touch pad key is pressed, the dryer cylinder will start rotating and the two-digit total dry cycle time, along with a decimal point, will appear on the dryer controller display.

The time shown on the dryer controller display will count down to the programmed cool down time. At that time, the display will change from the decimal point and two-digit number to a letter “C” and two digits.

The letter “C” represents the cool down portion of the dry cycle. The two digits represent the amount of time remaining in the dry cycle. The two-digit time, shown on the dryer controller display, will count down to zero.

When the time decrements to zero, the dryer controller display will flash the word “donE” and the end of cycle tone will sound.

At that point, the wrinkle free cycle will automatically begin. This cycle will wait two minutes, if the door is not opened or the STOP touch pad key on the dryer controller is not pressed, and then rotate the cylinder for 10 seconds and stop. This two minutes of idle time and 10 seconds of tumble time will repeat a total of 10 times, at which time the wrinkle free cycle stops. The cylinder will not rotate again until a new dry cycle is started.

---

During the wrinkle free cycle the gas valve will not be operated and there will be no heat applied to the load. The word “donE” will also continue to flash and do so even after the wrinkle free cycle is finished. When the dryer loading door is opened, or the STOP touch pad key is pressed, the word “donE” will change to the word “LOAd” on the dryer controller display. The dryer will then be ready for another dry cycle.

During the dry cycle, either pressing the STOP touch pad key on the dryer controller or opening the dryer loading door, will stop the dry cycle and not clear it. If you press the STOP touch pad key on the controller and then open the dryer loading door the dry cycle will not be cleared. **However, if you open (or open and close) the dryer loading door and then press the STOP touch pad key on the dryer controller, the present dry cycle will be cleared and the word “LOAd” will appear on the dryer controller display.**

There are two jumpers and one push button on the component side of the dryer controller printed circuit board.

The jumper located roughly in the middle of the circuit board controls whether the controller display shows and operates in the Fahrenheit or Celsius mode. This jumper is labeled as TEMP SELECT and has three pins. The top and middle pins are for Celsius and the bottom and middle pins are for Fahrenheit, which is indicated by the letter C for Celsius and the letter F for Fahrenheit.

The other jumper, located in the middle of the right side of the component side of the dryer controller circuit board, is used for choosing either a reversing or non-reversing type of dryer. This jumper is labeled as REV and NON-REV. This jumper must be in the non-reversing position, which are the bottom and middle pins. If the jumper is in the reversing position, the heating part of the dry cycle will not operate properly. The dryer will not reverse direction either.

The push button, which is located in the upper right side of the component side of the dryer controller circuit board, is used to reset all five of the dry cycles to the factory default settings. It is labeled as DEFAULT SETTINGS. Even the dry cycles that have been modified using the permanent programming procedure will be changed back to the factory default settings when using this push button. This push button must be pressed and held for at least three seconds with power applied to the dryer controller circuit board.

## Temporary Dryer Controller Programming

The temporary programming mode will allow the change of the stored dry cycle settings in the dryer controller for one complete dry cycle. After the dry cycle is complete, the default settings that existed before the temporary change are restored. The temporary dry cycle can be stopped and cleared at any time during the dry cycle operation.

To temporarily change a dryer controller cycle, follow the procedures below. Things that are displayed on the 4-digit numeric display will be in “quotation marks”. Keys on the dryer controller touch pad that physically need to be pressed will be in CAPITAL AND BOLD LETTERS.

If, at any time, you want to escape the temporary programming mode while changing the program settings, you can press the STOP key on the dryer controller touch pad if the 4-digit numeric display is not flashing. The SELECT/ENTER key on the dryer controller touch pad can be pressed and released to enter the flashing value shown on the 4-digit numeric display and allow you to escape.

If you press and release the STOP key on the dryer controller touch pad, when the 4-digit numeric display is not flashing, the temporary changes to the dry cycle program will be cancelled. The stored dry cycle settings that existed before the temporary change will then be restored.



---

If, at any time, you want to start the temporary dry cycle during the temporary programming mode, press and release the START key on the dryer controller touch pad if the 4-digit numeric display is not flashing. The SELECT/ENTER key on the dryer controller touch pad can be pressed and released to enter the flashing value shown on the 4-digit numeric display and allow you to start the temporary dry cycle. If you start the temporary dry cycle, the 4-digit numerical display will change to the total dry time and count down to 0 as the dry cycle progresses.

## Procedure

- 1) Make sure the dryer is not in a dry cycle. The 4-digit numeric display on the dryer controller will show "LOAD" when the dryer is not in a dry cycle.
- 2) Press and release the UP or DOWN arrow keys on the dryer controller touch pad to choose the dry cycle that you want to change (dry cycle 1 through 5). The dry cycle L.E.D. will illuminate to indicate which dry cycle you are choosing. If you press either arrow key and hold it down, the controller will sequence through the five dry cycles.
- 3) Press and release the CYCLE key on the dryer controller touch pad once you have chosen the dry cycle you want to change. After you press this key, the programming L.E.D. and the dry time L.E.D. will illuminate. The dry cycle L.E.D. will remain illuminated. The total dry time will also be displayed on the 4-digit numeric display.
- 4) Press and release the UP or DOWN arrow keys to change the total cycle time. Once either of the arrow keys is pressed, the dry time L.E.D. and the total dry time on the 4-digit numeric display will flash. If you press and hold either arrow key down, you will increment (UP arrow) or decrement (DOWN arrow) through the total dry times available (1 through 60 minutes). This displayed dry time includes the cool down time along with the heated time. To not change the total dry time, do not press the arrow keys to change the total dry time.
- 5) Press and release the SELECT/ENTER key. Once this key is pressed and released, the dry time L.E.D. will switch off, the dry cycle L.E.D. and programming L.E.D. will remain on, and the temperature L.E.D. will illuminate. The drying temperature will also be shown on the 4-digit numeric display.
- 6) Press and release the UP or DOWN arrow keys to change the drying temperature. Each press and release of the arrow keys will either increase or decrease the temperature by five degrees Fahrenheit or three degrees Celsius, depending on how your dryer controller is set up. Once either of the arrow keys is pressed, the temperature L.E.D. and the drying temperature on the 4-digit numeric display will flash. If you press and hold either arrow key down, you will increment (UP arrow) or decrement (DOWN arrow) your way through the available drying temperatures (105° Fahrenheit or 41° Celsius, up to 195° Fahrenheit or 90° Celsius). If you do not want to change the drying temperature, do not press the arrow keys. Go to the next step.
- 7) Press and release the SELECT/ENTER key. Once this key is pressed and released, the temperature L.E.D. will switch off, the dry cycle L.E.D. and programming L.E.D. will remain on, and the cool down L.E.D. will illuminate. The cool down time will also be shown on the 4-digit numeric display.
- 8) Press and release the UP or DOWN arrow keys to change the cool down time. Once either of the arrow keys is pressed, the cool down L.E.D. and the cool down time on the 4-digit numeric display will flash. If you press and hold either arrow key down, you will increment (UP arrow) or decrement (DOWN arrow) through the cool down times available (2 through 15 minutes). To not change the cool down time, do not press the arrow keys. Go to the next step.
- 9) Press and release the SELECT/ENTER key. Once this key is pressed and released, the cool down L.E.D. and the programming L.E.D. will switch off, and the dry cycle L.E.D. will remain on. The flashing cool down time on the 4-digit display will stop flashing and remain.

- 
- 10) At this point, you have two choices. 1) You can perform the modified dry cycle by pressing and releasing the START key on the dryer controller touch pad, or 2) You can clear the modified dry cycle program by pressing and releasing the STOP key once. If you start the modified cycle, the total dry time will appear on the 4-digit numeric display and it will count down to 0 as the dry cycle progresses. If you choose to clear the modified dry cycle, the 4-digit numeric display will change to "LOAd".

## Temporary Dryer Controller Programming Example

**REQUIREMENTS:** Dry a load with 40 minutes of actual heat at 185 °F and five minutes of cool down.

The following procedure will show you how to temporarily modify the existing dry cycle 1 program for one cycle of drying. It is based on the assumption that the factory defaults have not been permanently changed. If they have been changed, the steps of this procedure will be the same, but the values that are displayed will be different. The amount of times that the dryer controller touch pad UP or DOWN keys must be pressed and released may also be different.

If you want the change to be permanent, go to the "PERMANENT DRYER CONTROLLER PROGRAMMING" section of this manual.

### Procedure:

- 1) After the load has been placed in the dryer, press and release the UP or DOWN touch pad key on the dryer controller until the L.E.D. for dry cycle 1 is illuminated.
- 2) Press and release the CYCLE key on the dryer controller touch pad. You will see the number "35" on the dryer controller display. The programming L.E.D. and dry time L.E.D. will be illuminated.
- 3) Press and release the UP arrow key on the dryer controller touch pad 10 times so the display will show a flashing "45". When the UP arrow touch pad key is pressed the first time, the number "36" will be flashing on the dryer controller display. Each number after that will also flash.
- 4) Now, press and release the SELECT/ENTER touch pad key on the dryer controller. The number "45" will stop flashing and the dry time L.E.D. will switch off. The dryer controller display will now show "180", the temperature L.E.D. will illuminate, and the programming L.E.D. and dry cycle 1 L.E.D. will remain on.
- 5) Press and release the UP arrow key on the dryer controller touch pad one time so the controller display will show a flashing "185". Each press of the UP arrow key will increment the temperature by five degrees.
- 6) Now, press and release the SELECT/ENTER touch pad key on the dryer controller. The number "185" will stop flashing and the temperature L.E.D. will switch off. The dryer control display will now show a number "5", the cool down L.E.D. will illuminate, and the programming L.E.D. and dry cycle 1 L.E.D. will remain on.
- 7) Press and release the SELECT/ENTER key on the dryer controller touch pad, since the desired cool down time is five minutes. After you press the SELECT/ENTER touch pad key on the controller, the cool down L.E.D. and programming L.E.D. will switch off. The controller display will remain at "5" and the cycle 1 L.E.D. will remain on.

---

You are now ready to start the new dry cycle. This new dry cycle will be in effect for one dry cycle only. After the dry cycle is done, or if the STOP touch pad key on the dryer controller is pressed and released twice, consecutively, the cycle 1 program will revert to the factory default settings.

If you press the START touch pad key on the dryer controller, the controller display will change from the number "5" to the number "45" and dry cycle 1 will begin.

## Permanent Dryer Controller Programming

The permanent programming mode will allow the change of the stored dry cycle settings in the dryer controller until the operator physically changes them again. The factory default settings can be restored in the dryer controller by pressing the default settings pushbutton on the back (component) side of the dryer controller circuit board. It is labeled and located on the upper right side of the printed circuit board, as you face the component side of the board. It must be pressed and held down for at least three seconds.

To permanently change a dryer controller cycle, follow the procedure below. Things that are displayed on the 4-digit numeric display will be in "quotation marks". Keys on the touch pad that physically need to be pressed will be in CAPITAL AND BOLD LETTERS.

If, at any time, you want to escape the permanent programming mode while changing the settings, you can press the STOP key on the dryer controller touch pad if the 4-digit numeric display is not flashing. The SELECT/ENTER key on the dryer controller touch pad can be pressed and released to enter the flashing value shown on the 4-digit numeric display and allow you to escape.

### Procedure

- 1) Make sure the dryer is not in a dry cycle. The 4-digit numeric display on the dryer controller will show "LOAD" when the dryer is not in a dry cycle.
- 2) Press and release the PROG key on the dryer controller touch pad.
- 3) Press and release the UP arrow key on the dryer controller touch pad. The programming L.E.D. will illuminate and the 4-digit numeric display on the dryer controller will change to "Prog".
- 4) Press and release the UP or DOWN arrow keys to choose the dry cycle you want to change (dry cycle 1 through 5). The dry cycle L.E.D. will illuminate to indicate which dry cycle you are choosing. If you press either arrow key and hold it down, the controller will sequence through the five dry cycles.
- 5) Press and release the SELECT/ENTER key once you have chosen the dry cycle you want to change. After you press this key, the dry time L.E.D. will illuminate. The dry cycle L.E.D. and the programming L.E.D. will remain illuminated. The total dry time will also be displayed on the 4-digit numeric display.
- 6) Press and release the UP or DOWN arrow keys to change the total dry time. Once either of the arrow keys is pressed, the dry time L.E.D. and the total dry time on the 4-digit numeric display will flash. If you press and hold either arrow key down, you will increment (UP arrow) or decrement (DOWN arrow) through the total dry times available (1 through 60 minutes). This displayed dry time includes the cool down time along with the heated time. To not change the total dry time, do not press the arrow keys. Go to the next step.
- 7) Press and release the SELECT/ENTER key. Once this key is pressed and released, the dry time L.E.D. will switch off, the dry cycle L.E.D. and programming L.E.D. will remain on, and the temperature L.E.D. will illuminate. The drying temperature will also be shown on the 4-digit numeric display.

- 
- 8) Press and release the UP or DOWN arrow keys to change the drying temperature. Each press and release of the arrow keys will either increase or decrease the temperature by five degrees Fahrenheit or three degrees Celsius, depending on how your dryer controller is set up. Once either of the arrow keys is pressed, the temperature L.E.D. and the drying temperature on the 4-digit numeric display will flash. If you press and hold either arrow key down, you will increment (UP arrow) or decrement (DOWN arrow) your way through the available drying temperatures (105° Fahrenheit or 41° Celsius, up to 195° Fahrenheit or 90° Celsius). If you do not want to change the drying temperature, do not press the arrow keys. Go to the next step.
  - 9) Press and release the SELECT/ENTER key. Once this key is pressed and released, the temperature L.E.D. will switch off, the dry cycle L.E.D. and programming L.E.D. will remain on, and the cool down L.E.D. will illuminate. The cool down time will also be shown on the 4-digit numeric display.
  - 10) Press and release the UP or DOWN arrow keys to change the cool down time. Once either of the arrow keys is pressed, the cool down L.E.D. and the cool down time on the 4-digit numeric display will flash. If you press and hold either arrow key down, you will increment (UP arrow) or decrement (DOWN arrow) through the cool down times available (2 through 15 minutes). To not change the cool down time, do not press the arrow keys. Go to the next step.
  - 11) Press and release the SELECT/ENTER key. Once this key is pressed and released, the cool down L.E.D. will switch off, the dry cycle L.E.D. and programming L.E.D. will remain on, and the 4-digit numeric display will change to “Prog”.
  - 12) Press and release the STOP key to save the cycle program and escape the programming mode. If you want to change the same dry cycle program again, press the SELECT/ENTER key and continue at step 6 of this procedure. If you want to modify another dry cycle program, go to step 4 of this procedure and continue.
  - 13) If you pressed the STOP key to escape the programming mode, you may now start the dry cycle by pressing the START key.

## Permanent Dryer Controller Programming Example

**REQUIREMENTS:** Dry a load with 50 minutes of actual heat at 195 ° F and three minutes of cool down.

The following procedure will show you how to permanently modify the existing dry cycle 1 program for one cycle of drying. It is based on the assumption that the factory defaults have not been permanently changed. If they have been changed, the steps of this procedure will be the same, but the values that are displayed will be different. The amount of times that the dryer controller touch pad UP or DOWN keys must be pressed and released may also be different. If you want the change to be temporary (for only one dry cycle), go to the “TEMPORARY DRYER CONTROLLER PROGRAMMING” section of this manual.

### PROCEDURE:

- 1) After the load has been placed in the dryer, press and release the UP or DOWN touch pad key on the dryer controller until the L.E.D. for dry cycle 1 is illuminated.
- 2) Press and release the PROG touch pad key on the dryer controller. The dryer controller display will not change.

- 
- 3) Immediately, press and release the UP arrow key on the dryer controller touch pad. The controller display will change from "LOAD" to "Prog". You have now entered the permanent programming mode. The dry time L.E.D. will remain on and the programming L.E.D. will illuminate.
  - 4) Press and release the SELECT/ENTER touch pad key once. The dry time L.E.D. and programming L.E.D. will remain on and the dry time L.E.D. will illuminate. The dryer controller will also show the number "35".
  - 5) Press the UP arrow touch pad key 18 times until the dryer controller display shows the number "53".
  - 6) Press and release the SELECT/ENTER touch pad key once. The dry time L.E.D. and programming L.E.D. will remain on and the dry time L.E.D. will switch off. The temperature L.E.D. will illuminate and the dryer controller display will show the number "180".
  - 7) Press and release the UP arrow touch pad key three times until the dryer controller display shows the number "195".
  - 8) Press and release the SELECT/ENTER touch pad key. The dry time L.E.D. and the programming L.E.D. will remain on and the temperature L.E.D. will switch off. The cool down L.E.D. will illuminate and the dryer controller display will show the number "5".
  - 9) Press and release the DOWN arrow touch pad key twice until the dryer controller display shows the number "3".
  - 10) Press and release the SELECT/ENTER touch pad key. The dry time L.E.D. and the programming L.E.D. will remain on and the cool down L.E.D. will switch off. The dryer controller display will change to "Prog".
  - 11) Press and release the STOP touch pad key. The dry time L.E.D. will remain on and the programming L.E.D. will switch off. The dryer controller display will change to the word "LOAD".

The dryer is now ready for the new modified dry cycle to start. This modified dry cycle 1 program will remain in the dryer controller memory until the default settings push button is pressed. This default settings push button is located on the component side of the dryer controller printed circuit board in the upper right corner.



---

# **Section 3:**

## **Wiring Schematics**

# Wiring Diagram 55 Pound OPL Dryer

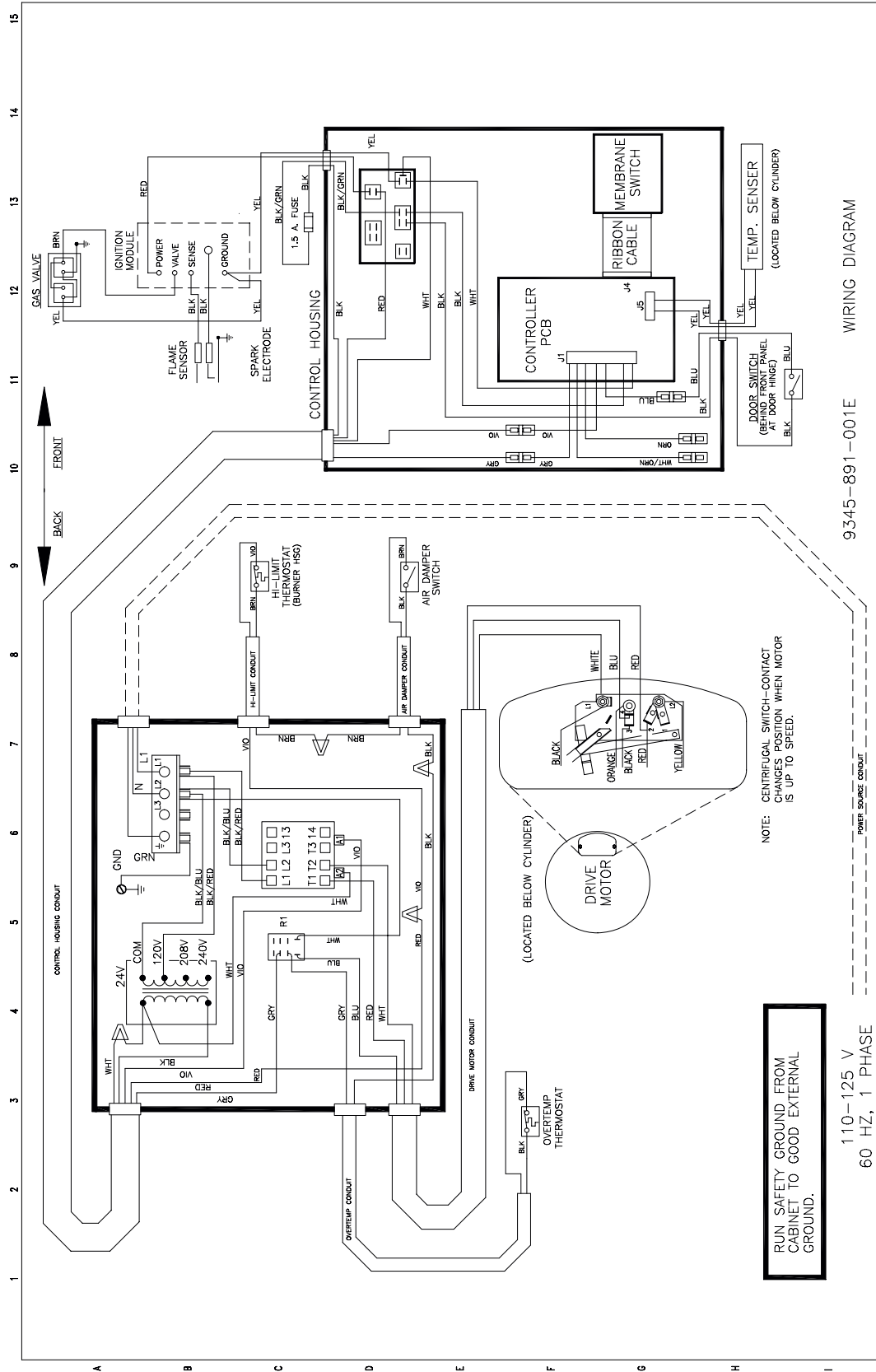

9345-891-001E WIRING DIAGRAM

110-125 V  
60 HZ, 1 PHASE

NOTE: CENTRIFUGAL SWITCH-CONTACT  
CHANGES POSITION WHEN MOTOR  
IS UP TO SPEED.

POWER SOURCE CONDUIT





# Informative for Parts

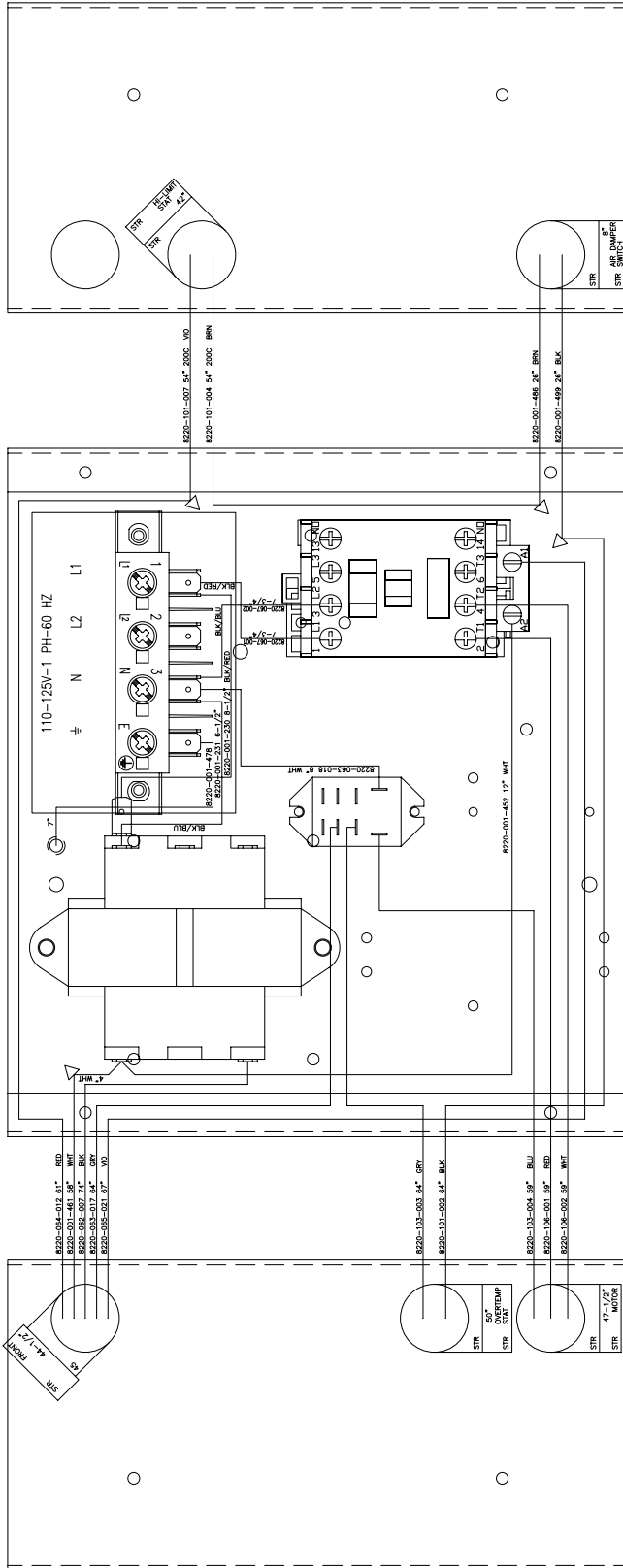

DTCH55 60HZ

SAMPLE BOX

INFORMATIVE 6102-018-055

9041-081-001H

---

# **Section 4:**

## **Service Procedures**

---

## Pressure Testing

The dryer and its individual shutoff valve must be disconnected from the gas supply piping system during any pressure testing of that system at test pressures in excess of ½ psig. The dryer must be isolated from the gas supply piping system by closing its individual manual shutoff valve during any pressure testing of the gas supply piping system at test pressures equal to or less than ½ psig.

## Clothes Door Removal

**STEP 1:** The clothes door may be removed from the hinge bracket by unscrewing and removing the allen head pivot screw located at the door upper hinge point.

**STEP 2:** Next lean the door out of the top of the hinge bracket and lift the door from the bottom hinge pin.

## Clothes Door Latch Adjustment

**STEP 1:** Loosen the lock nut on the latching stud. It is located directly behind the door handle.

**STEP 2:** Open the loading door.

**STEP 3:** Screw the door catch stud in or out as necessary and then retighten the lock nut.

## Installation of Clothes Door Window & Gasket

**STEP 1:** Remove the loading door.

**STEP 2:** Place the clothes door, with its face down, on a solid surface.

**Note:** Pre-warming the gasket under a heat lamp makes the installation much easier.

**STEP 3:** Put the door glass gasket on the loading door with the ridges in the wide side up. Locate the seam at the door latching stud.

**Note:** The gasket has one narrow opening on one side and a wide opening on the other. The narrow side mounts to the door. The wide side holds the glass. The wide side has ridges on one interior lip. This ridged side should go up with the door laying face down.

**STEP 4:** Coat the inside and outside of the gasket with rubber lubricant or liquid soap.

**STEP 5:** Slide the glass into the middle of the gasket with half of the glass above the door and half below the door.

**STEP 6:** While pressing on the glass, use a modified screwdriver (grind the end off so that it is round and put a slight bend in it) and run it around half of the glass.

---

**STEP 7:** With half of the glass installed, turn the door over and repeat step 6.

**STEP 8:** Insert the modified screwdriver at the 6 o'clock position and pry the glass up enough to install the door glass support spacer (small diameter rubber tube).

## Door Switch Removal & Installation

**STEP 1:** The door switch is located directly behind the hinge plate of the loading door assembly. Open the door for access to the switch area. Remove the two screws holding the switch box cover in position. This will allow the removal of the cover and the switch actuator plate.

**STEP 2:** The entire switch box can now be pulled from the front panel opening, creating access to the door switch mounting screws.

**STEP 3:** Remove these two mounting screws and twin nut which frees the door switch and insulating shield. Remove wires.

**STEP 4:** When installing the door switch make certain the insulating shield is reassembled.

**STEP 5:** The actuator plate and switch box cover should be assembled as illustrated in the parts section of this book.

## Door Switch Operation & Testing

The normally open door switch must be closed (0 ohms resistance) for the motor and heat circuits to operate. When the door is opened, the door switch breaks the 24 volt control circuit.

## Door Switch Adjustment

**STEP 1:** Remove the two switch box cover screws.

**STEP 2:** Remove the switch cover and actuator plate.

**STEP 3:** Pull the entire switch box out from the opening in the front panel.

**STEP 4:** Loosen the bottom door switch mounting screw.

**STEP 5:** A slotted mounting allows the switch to slide in or out for adjustment.

## High Limit Thermostat Locations & Functions

### Burner Housing

This hi-limit is located on the left side of the burner housing.

**STEP 1:** The thermostat opens the circuit to the main burners in the event of malfunction

---

in the gas control area or temperature control. This thermostat will open quickly if there is a significant loss of air flow over the burner area.

**STEP 2:** It is covered by a guard and is held in place by two screws. There are spacers between the thermostat and bracket which must be used to give proper operation.

**REMOVAL:** To remove either the hi-limit thermostat on the rear of the burner housing or the over-temperature thermostat on the right side of the burner housing, remove the mounting screws holding its respective guard. Next, remove the terminal of each wires attached to the thermostat. Lastly, remove the mounting screws holding the thermostate to the burner housing.

### **Manual Resettable Over Temperature Safety Thermostat**

The second hi-limit thermostat is located outside the rear exhaust opening mounted on back panel of the machine.

**STEP 1:** The manually resettable thermostat limits the operating temperature a dryer can reach should some abnormal situation occur.

**STEP 2:** Should the thermostat be tripped, the dryer will cease to heat until the thermostat is reset. Once the dryer cools, the thermostat may be reset by inserting a pencil or stick through the opening in the thermostat cover and pushing the button in.

**REMOVAL:** To remove either the hi-limit thermostat on the rear of the burner housing or the over-temperature thermostat on the right side of the burner housing, remove the mounting screws holding its respective guard. Next, remove the terminal of each wires attached to the thermostat. Lastly, remove the mounting screws holding the thermostate to the burner housing.

### **Pressure Regulator Adjustment**

Use the following procedure whenever it is necessary to check the pressure regulator setting. NOTE: Any adjustment of the pressure regulator must be made with a manometer attached at the plug in the main burner manifold.

**STEP 1:** Shut off the gas supply to the dryer.

**STEP 2:** Remove the 1/8" pipe plug from the end of the main burner manifold.

**STEP 3:** Attach a manometer to the manifold end.

**STEP 4:** Remove the pressure regulator cover screw on the gas valve.

**STEP 5:** Open the shut-off valve, and operate the dryer.

**STEP 6:** Adjust the pressure for a manometer reading of 3.5" water column gas pressure. (11.0" for L.P.)

**NOTE:** The main burners must be operating when adjusting the pressure regulator.

---

**STEP 7:** Shut off the gas supply to the dryer. Remove the manometer and install the 1/8" pipe plug in the manifold.

**STEP 8:** Open the shut off valve, start the dryer and check for gas leaks while the burners are ignited.

### **Front Panel Removal**

To remove the front panel, first remove the loading door from the panel. Then remove the two left side screws and the four right side screws. The trim does not have to be removed. (The panel may be removed with the door left in place, although it is much heavier and more awkward to do so.)

**NOTE:** Always remove power from the machine before changing drive belts or working with the drive and fan system.

### **Final Drive Belt Replacement**

To replace the final drive belt turn the cylinder slowly by hand and work the belt off of the large pulley.

### **Motor Drive Belt Replacement**

To replace the motor drive belt the final drive belt should be removed as above. Next turn the intermediate drive pulley and work the belt off of it similarly to the above belt.

### **Blower Impeller Removal**

Remove the lint hood that is located inside the lower service door. Take notice of the location of the impeller location on the shaft. Remove the two set screws that hold the motor to the shaft.

### **Air Switch Removal & Adjustment**

The air switch assembly is part of the ignition safety circuit and insures that the burners don't operate unless there is air flow. If this doesn't happen ignition will not occur. The air switch assembly is mounted on the right rear of the back panel at about half way up.

### **Electronic Ignition Module**

This machine uses an electronic spark ignition system to directly light the burners.

**STEP 1:** The electronic ignition module (gray box) is located inside the upper access door in the control box.

**STEP 2:** The red wire from the transformer provides 24 VAC through the 1.5 amp fuse and into the module to operate the entire direct ignition system.

**STEP 3:** The black colored hi-voltage wire (spark plug type) plugs onto the post connector on the module, and the multi-wire plug fits into the side of the module.

### **Spark Electrode Assembly-Removal**

**STEP 1:** Remove electrode cover and disconnect wires to electrodes.

## Spark Electrode Assembly-Function

1. The spark electrode and sensing electrodes are located directly at the side of the burner housing.
2. The electrode with the black hi-voltage wire conducts the spark to the center grounding probe, directly over the burner.
3. The electrode with the black sensing wire detects ignition and monitors flame by signaling the module.

**NOTE:** Proper grounding of the ignition system (yellow wires) is very critical for proper ignition sequence.

## Ignition System-Function & Sequence

During normal dryer operation, the following occurs:

1. The dryer electronic control calls for heat.
2. From the 24VAC control transformer, voltage for the heat circuit is applied to the control through the door switch. If the control sense that the heat should be on, a circuit is closed providing power through the over-temp thermostat, the air damper switch, the high limit switch and the motor centrifugal switch to the Ignition Module. Once the 24VAC reaches the ignition module on the red wire, sparking occurs at the ignition electrode and 24VAC is applied to open the Gas Valve.
3. Once the flame is established, the sensing electrode detects the presence of flame and the sparking stops.
4. If for any reason the flame is not established in a period of 10 seconds, the electronic control will try this sequence for 3 tries. Normally the 10 seconds "Trial For Ignition" period is ample to establish and prove flame.
5. If the flame is shutdown or blown out during operation, the ignitor will immediately go into "Trial. For Ignition" again for 10 seconds.
6. However, at the end of 3 separate retries of 10 seconds "Trial for Ignition", the flame is not established, the ignition system goes into "Safety Lock-Out" and will not reactivate the "Trial for Ignition" until there is a current interruption for a period of 15 seconds. This interruption can be provided by opening the dryer loading door and allowing the machine to come to a complete stop for 15 seconds.

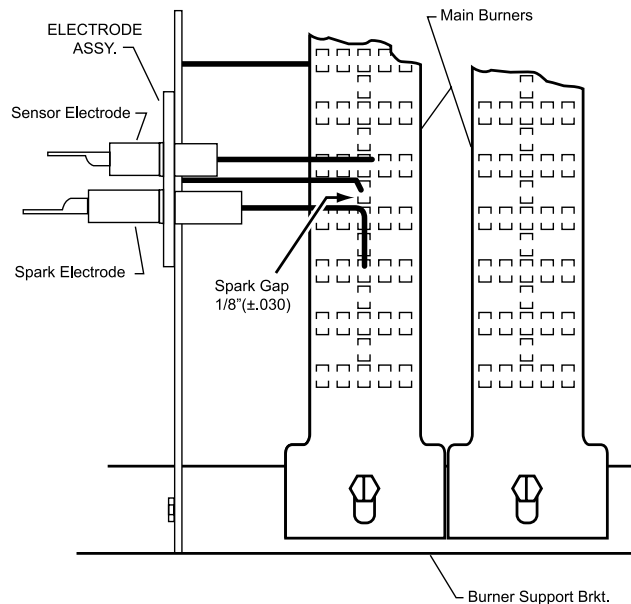

**IMPORTANT:**  
Electrodes are positioned 3/8" above burner surface.  
Electrode ends are centered to burner.



---

**STEP 2:** Remove two screws to detach electrode assembly.

**NOTE:** Proper grounding of the ignition system (yellow wires) is very critical for proper ignition sequence

If there is no spark or intermittent spark, check black hi-voltage lead wire for damage or cracks in insulation. *This lead wire must not be taped or connected to any metal edges along its length to prevent pinching and arcing. Also, do not bundle this wire with other wires.*

**NOTE:** Spark gap and electrode location are important. If the electrode is damaged or mounting is changed the spark gap may not be correct for ignition to occur. Check for cracks in the ceramic insulator. Replace electrode assembly if necessary. Also check for carbon or foreign material on the electrodes and clean if necessary.

## Gas Valve & Manifold Removal

**STEP 1:** Disconnect union at gas valve and disconnect wires from gas valve operator coils.

**STEP 2:** Remove right manifold mounting bracket screws and slide manifold to remove from left bracket.

## Main Burner Orifice Removal

**STEP 1:** Remove manifold and gas valve assembly as above.

**STEP 2:** Using an open end wrench, remove orifices from manifold.

## Main Burner Removal

Remove manifold & gas valve assembly as previously discussed. Remove the screw securing the front of the burner to the support bracket. The burner may now be removed.

## Cylinder Pulley Removal

Remove nut holding pulley to cylinder shaft. Pull pulley straight off of shaft. Do not lose the tolerance ring that grips the shaft.

## Intermediate Pulley Removal

The intermediate pulley can be removed by removing the snap ring holding the pulley to the tension arms.

## Tension Arm Assembly Removal

The tension arm assembly may be removed by removing the snap ring that holds it to the tension arm support assembly pin. If it is necessary the arm assembly is replaced as a complete unit .

---

## Tension Arm Support Assembly Adjustment

The tension arm support assembly may be adjusted for alignment of the intermediate pulley and also to align the belts. The three outer nuts allow the alignment of the pin to be adjusted by pivoting the assembly on the center bolt. The center bolt can be screwed in to allow bringing the complete assembly farther back if necessary for belt alignment.

## Cylinder Removal

Step 1 Remove the front panel in front of the cylinder.

Step 2: Remove drive belt, pulley, and tolerance ring from cylinder shaft.

Step 3: Pull the cylinder from the front of the machine.

## Adjustment of Cylinder Assembly

**STEP 1:** Loosen the two top adjusting bolts and two bottom adjusting nuts and lock nuts holding the bearing housing to the drive plate.

**STEP 2:** Loosen the four mounting bolts on the side channels.

**STEP 3:** Open the clothes door and insert a 1/2" thick shim at the 3 and 9 o'clock positions and a 1/4" thick shim at the 6 o'clock position.

**STEP 4:** Tighten the two bottom adjusting nuts and tighten locking nuts.

**STEP 5:** Tighten the bottom right mounting bolt, then the top left mounting bolt. Tighten the remaining two bolts. (Shim where and if necessary.)

**STEP 6:** Tighten the two top adjusting bolts.

**STEP 7:** Remove all the shims from between the front panel flange and cylinder (3,6,9 and 12 o'clock).

**STEP 8:** Spin the cylinder to check for rubbing baffles, pressing down hard while rotating. If rubbing is detected, repeat procedure paying particular attention to placement of shims between bearing housing and side channels.

## Bearing Housing Removal

After removing cylinder as previously outlined, simply unbolt the bearing housing and remove.

---

# **Section 5:**

## **Trouble Shooting**

## Section 5: Trouble Shooting - Gas Heated

Symptom	Probable Cause	Suggested Remedy
Tumbler does not turn	Drive belts	Check both drive belts
	Drive motor	Check capacitor and motor
	Door switch	Check door switch contacts and adjustment
	Micro control	Check that LED's are lit and green start key pushed
	Motor Relay	Check motor relay coils (24v) and contacts.
Tumbler turns but no spark temperature	Temperature	Check for selected in formula at burner
	Spark Electrode	Check electrode for damage to electrode or mounting
	Temperature Sensor	Check by plugging in good sensor
	Ignition Transformer	Check for 24 V out of transformer to ignition control
	Ignition control Air flow switch	Try another control Check for circuit through air flow switch
	Hi-limit	Check hi-limit
	Over-temp	Check by inserting pencil eraser side thru (Manual Reset) hole and push to reset
	Gas supply	No gas can cause system lockout check for W.C.

Symptom	Probable Cause	Suggested Remedy
<b>Tumbler turns ignition sparks no flame</b>	Gas supply	Make sure gas supply is working
	Gas pressure	Make manometer check of gas pressure for 3 .5"W.C. natural 11"W.C. propane
	Spark electrode	Check electrode for damage to electrode or mounting
	Gas valve	Check coil continuity, replace valve if bad
<b>Slow drying</b>	Thermostat	What is temperature set at on control
	Air flow Restrictions	Follow installation guidelines for static back pressure and make up air
	Lint screen	Clean screen
	Exhaust	Check complete exhaust system for excessive back pressure in the duct work. No more than .3 static pressure
	Makeup air	Check for adequate makeup air (1.25 sq. Ft.)
	Temp sensor	Clean or replace sensor if necessary
	Gas	Gas pressure at burner should be ( 3.5" W.C.) while burning
	Blower Impeller	Check impeller for operation and check mounting set screw
	Steam & Electric Heated	Check relay for activation. Check steam Check steam valve for steam trough

## Dryer Fault Codes

FAULT#	FAULT DESCRIPTION	ACTION
F1	Shorted thermostat sensor	Dryer stops and "F1" flashes on the 4- digit display. When short circuit on sensor input is removed, "LOAD" appears on the 4-digit display and the remaining dry time is reset.
F2	Open thermostat sensor	Dryer stops and "F2" flashes on the 4-digit display. When a good sensor is connected to sensor input, "LOAD" appears on the 4-digit display and the remaining dry time is reset.
F3	EEPROM corrupted.	Dryer will not start and "F3" appears on the 4-digit display. The power to the dryer must be cycled to reset the controller. Fault should only occur when starting a dry cycle.
F4	Gas valve on fault.	The drying temperature did not increase 1°F. in 5 minutes. "F4" will flash on the display and the dry cycle will finish without calling for heat (energizing gas valve). Opening the door or pressing the STOP key will reset the fault and clear the remaining time in the dry cycle.
F5	Temperature fault.	The drying temperature is at least 25°F. above the temperature setting. "F5" will flash on the 4-digit display and the dry cycle will finish without calling for heat (energizing the gas valve). The power to the dryer must be cycled to reset the controller.

---

# **Section 6:**

## **Parts Data**

## Section 6: Parts Data - Cabinet Group

Key	Part Number	Description	Quantity
*	9960-285-005	Door Assy., Loading Complete-Wht .....	1
*	9960-285-004	Door Assy., Loading Complete-SS .....	1
1	9960-284-002	Door Ring ONLY, Loading-SS .....	1
2	9982-360-003	Plate Assy., Hinge (Wht).....	1
2	9982-360-001	Plate Assy., Hinge (SS).....	1
*	9545-012-015	Screw, Hinge to Door 10-32 x 3/8" .....	4
*	8640-413-002	Nut, Hinge to Door #10-32 UNF .....	4
3	9212-002-004	Glass, Door.....	1
4	9206-164-010	Gasket, Glass .....	1
*	9548-117-000	Support, Door Glass (inside gasket).....	1
5	9206-420-004	Gasket, Outer Rim .....	1
6	9244-082-001	Handle, Loading Door.....	1
*	9545-018-017	Screw, Handle 1/4"-20 x 3/8" .....	2
*	9531-033-001	Stud, Door Catch .....	1
*	8640-413-001	Nut, Hex.....	1
*	8640-413-003	Nut , Acorn # 10-32 .....	1
*	9086-015-002	Catch, Loading Door.....	1
*	8638-190-009	Rivet, Door Latch.....	2
7	9454-809-007	Panel Assy., Front- White .....	1
7	9454-809-001	Panel Assy., Front- S. Steel.....	1
8	9108-102-001	Door, Upper Service-S.S.....	1
8	9108-102-004	Door, Upper Service-White .....	1
9	9578-091-003	Trim, Door-Upper Service.....	1
	6292-006-006	Key ( only ) (FJWCC).....	1
10	8650-006-003	Lock w/ nut, Upper Service Door .....	1
*	9491-009-001	Rivet, Drive, Upper Door Mounting.....	2
*	8641-581-005	Washer, Flat 3/16" Upper Door Mounting.....	2
*	9548-268-001	Support, Upper Door .....	1
11	9412-127-001	Nameplate, Commercial Dryer .....	1
12	9545-012-003	Screw, Chrome 10-32 x 1/2".....	4
*	8641-436-004	Washer, Fiber .....	4
*	8641-582-019	Lockwasher # 10 .....	10
*	8640-399-001	Nut, Spring U type 10Z.....	6
13	9544-069-002	Strap, Hinge (White) .....	1
13	9544-069-004	Strap, Hinge (Gray).....	1
*	9545-008-032	Screw, Hinge to Panel 10T-32 x 3/4" .....	4
14	9545-052-001	Screw, Door to Hinge Strap (special) .....	1
*	8641-436-003	Washer, Fiber/ Plastic VSCO on Door Hinge (special).....	1
15	9960-280-001	Door Ass'y, Lower Service-SS .....	1
15	9960-280-003	Door Ass'y, Lower Service-White .....	1
*	9277-050-001	Insulation Lower Door.....	1
16	9578-088-002	Trim, Door - Lower Service.....	1
23	9435-016-002	Overlay Trim .....	1
17	9545-008-021	Screw,Pn Hd Cr., #10Bx3/8 .....	5
18	9578-084-003	Trim, Kick- Lower Service Door.....	1
19	9545-008-010	Screw, Tr Hd Cr-#10x1/2 Blk .....	3
20	9244-084-001	Latch, Lower Door (Handle).....	1
*	8502-617-001	Label - Made in the USA .....	1
*	9277-051-002	Insulation Side Panel - Lower Service Area .....	3



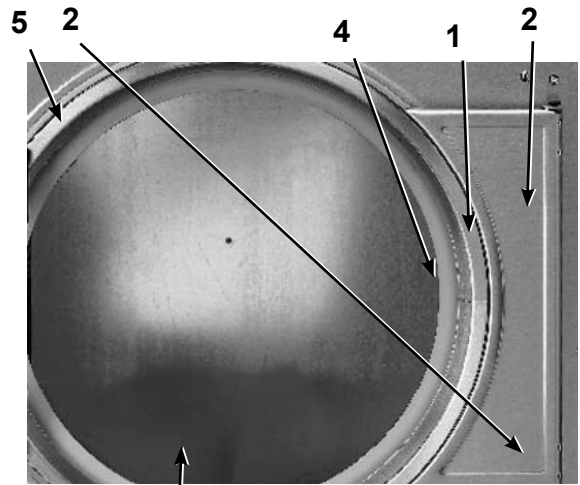
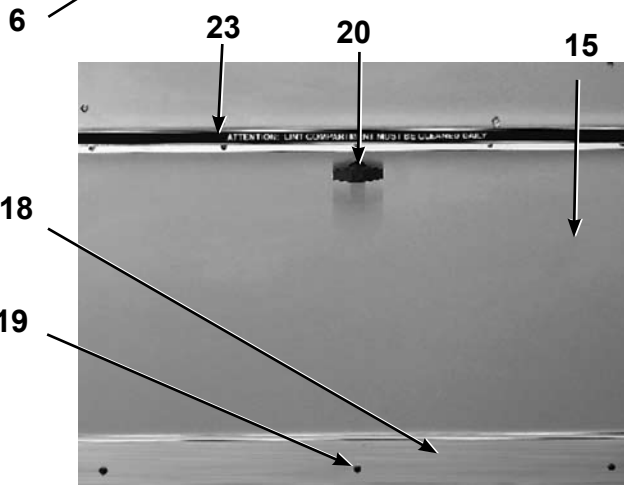
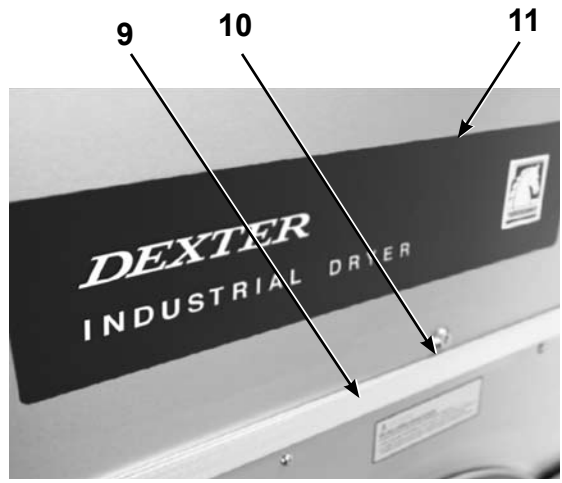
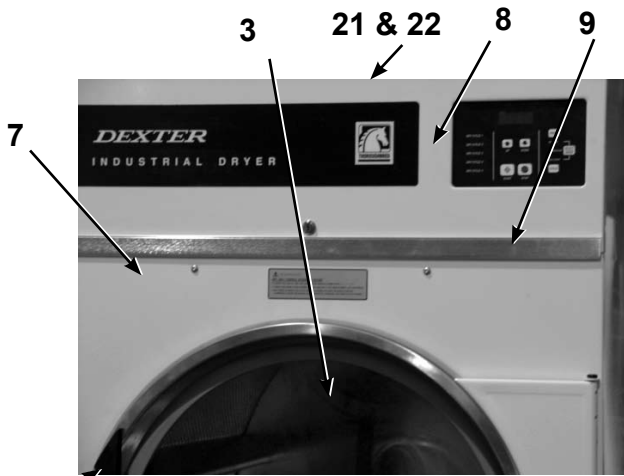

**Baffle Right**

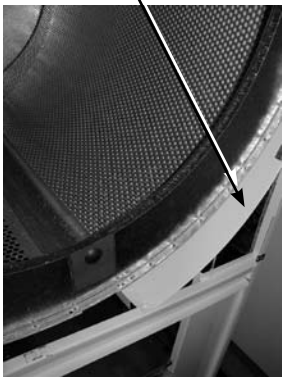

Key	Part Number	Description	Quantity
*	9277-051-001	Insulation Side Panels - Around Basket .....	6
*	9277-055-002	Insulation Front Panel Bottom .....	1
*	9277-055-001	Insulation Front Panel Top .....	1
*	8544-006-001	Leg, Leveling .....	4
*	9812-012-001	Baffle, Cabinet- Left Inside Cabinet.....	1
*	9812-012-001	Baffle, Cabinet- Right Inside Cabinet .....	1
*	9545-008-003	Screw, #10x1/2 TEK .....	8
21	9074-276-001	Cover, Cabinet.....	1
22	9545-008-024	Screw 10AB x 3/8" .....	10
*	9277-041-003	Insulation .....	1
*	9277-047-002	Insulation 1/4" black.....	1

\* Not Illustrated

## Front Control Housing Group

Key	Part Number	Description	Quantity
2	9627-770-001	Wiring Harness Micro .....	1
3	9897-026-001	Terminal Block Assembly .....	1
4	9545-031-004	Screw 6AB x 3/8" (for terminal block).....	2
5	9801-085-001	Membrane Switch Assembly .....	1
6	9732-249-001	PCB Board Controller Kit.....	1
8	9982-326-002	Plate Assembly,Control Mounting.....	1
9	9451-146-005	Pin- Hinge meterplate.....	2
11	9054-045-001	Fuseholder.....	1
*	9545-031-005	Screw - Fuse Holder Mounting .....	1
12	8636-018-001	Fuse 1.5 amp.....	1
13	9857-116-003	Control, Ignition .....	1
*	9545-044-002	Screw - Ignition Control Mounting .....	2
*	8640-411-003	Nut - Ignition Control Mounting.....	2
14	9631-403-003	Wire Ass'y High Voltage (from ignition control) .....	1
*	8636-024-001	Electronic Control PCB Fuse on PCB .600 MA/250V .	1
15	9501-004-002	Temperature Sensor .....	1
*	9627-679-002	Sensor Wire Harness .....	1
*	9029-111-001	Bracket Sensor Mounting .....	1
*	9545-045-005	Screw Mounting Bracket 8B x 1/4" .....	1

\* Not Illustrated

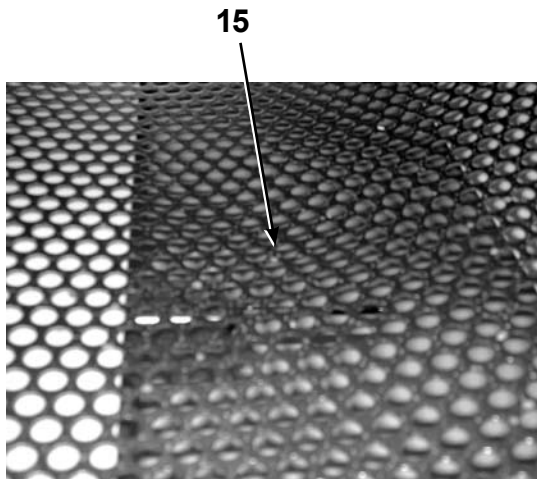
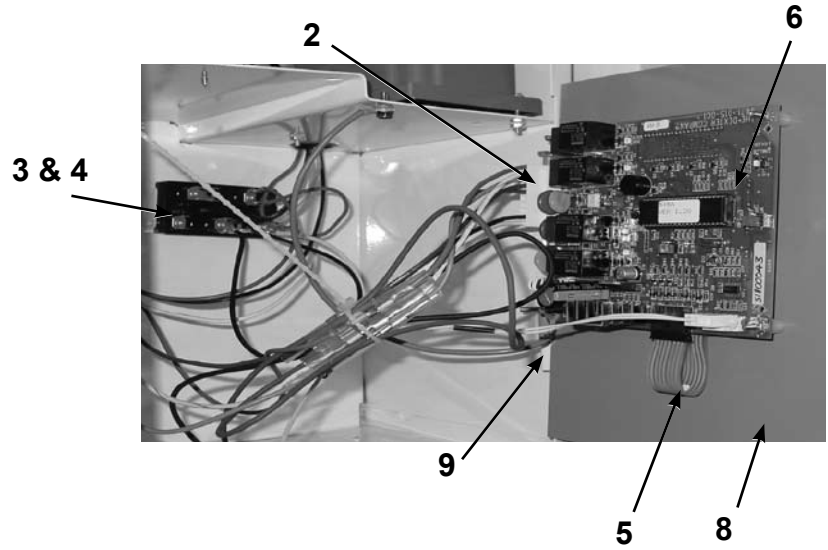
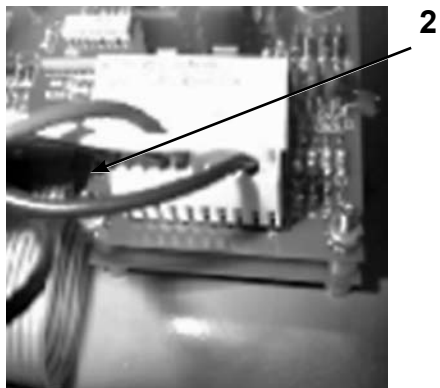
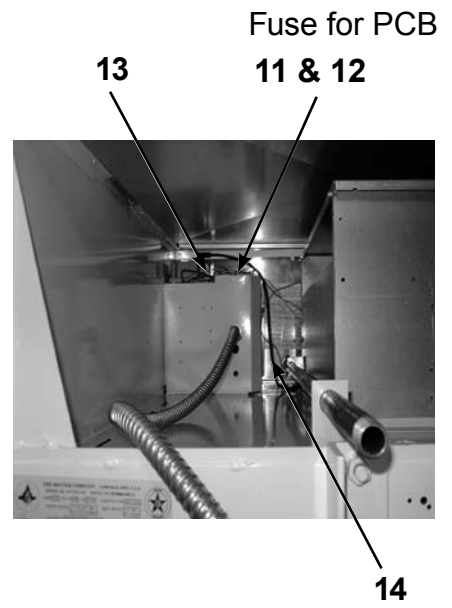
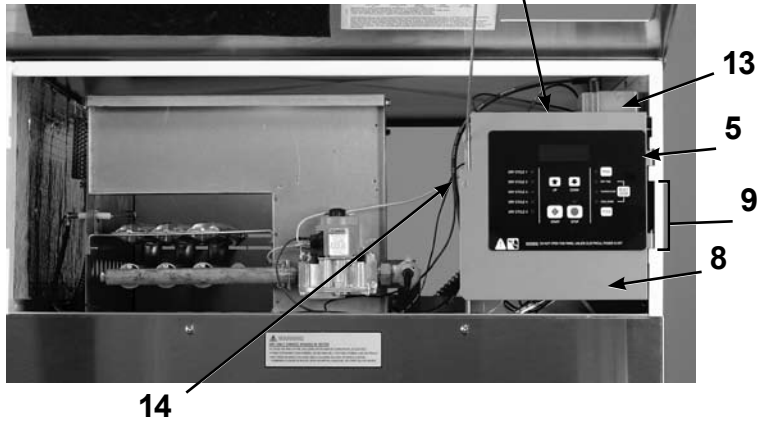

# Drive Group

Key	Part Number	Description	Quantity
1	9376-300-001	Motor, Drive.....	1
*	9545-014-004	Screw, Hx 5/16-18 x 5/8".....	4
*	8640-400-003	Nut 5/16-18.....	4
2	9453-169-010	Pulley, Motor.....	1
*	9545-028-013	Screw, Set.....	2
3	9991-054-004	Support Assembly, Motor.....	1
4	9545-014-004	Screw.....	4
*	8640-400-003	Nut.....	4
5	9991-053-001	Support Assembly, Intermed. Pulley.....	1
6	9545-029-010	Bolt, Rd Hd, 3/8-16 x 1 1/4".....	3
7	9545-029-003	Screw, 3/8-16 x 1 1/2".....	1
8	8640-415-004	Nut 3/8-16.....	3
*	8641-581-035	Washer, Flat.....	4
9	9861-024-003	Arm Assembly-Tension.....	1
*	8641-581-035	Washer, Flat.....	1
*	9487-200-006	Ring-Retaining.....	1
10	9908-042-006	Pulley Assembly, Intermediate - w/bearings.....	1
11	9036-159-007	Bearing, Ball-Idler Pulley.....	2
*	9538-173-002	Spacer, Bearing.....	1
12	9908-043-002	Pulley Driven.....	1
*	9487-234-001	Ring, Tolerance.....	1
13	8641-581-026	Washer, Flat.....	1
13	8641-582-016	Lockwasher.....	1
13	9545-017-009	Screw, Hx Cap.....	1
14	9040-077-005	Belt, Final Drive.....	1
15	9040-077-003	Belt, Motor Drive.....	1
16	9534-151-000	Spring, Belt Tension.....	1
17	9099-012-002	Chain, Spring Tension.....	1
18	9248-022-002	Hook, Tension.....	1
*	9208-066-001	Guard, Drive.....	1
*	9454-692-001	Panel, Drive Guard, RH.....	1
*	9454-693-001	Panel, Drive Guard, LH.....	1
*	9550-175-001	Shield, Motor.....	1
*	9545-008-003	Screw.....	2
*	9545-008-024	Screw (to attach to guards above).....	30

\* Not Illustrated

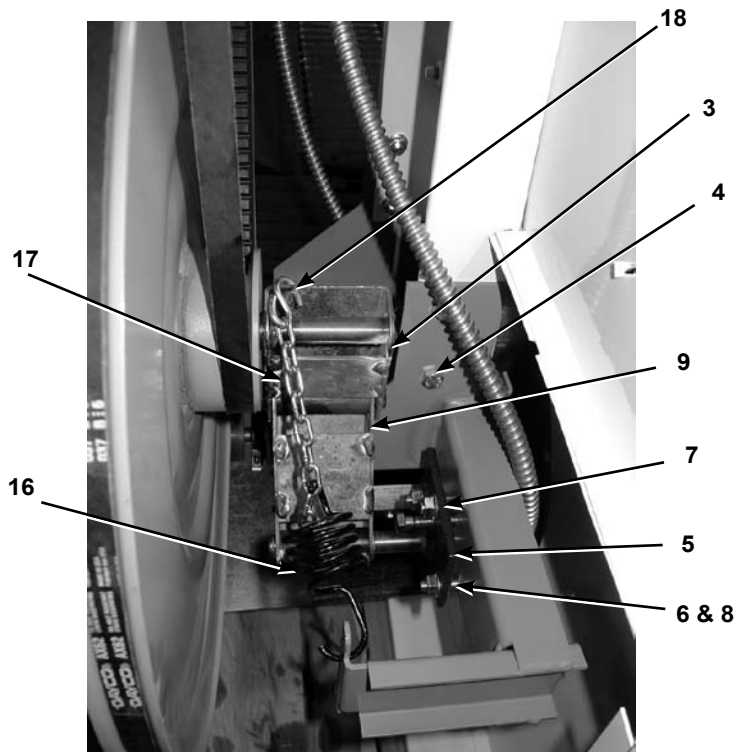
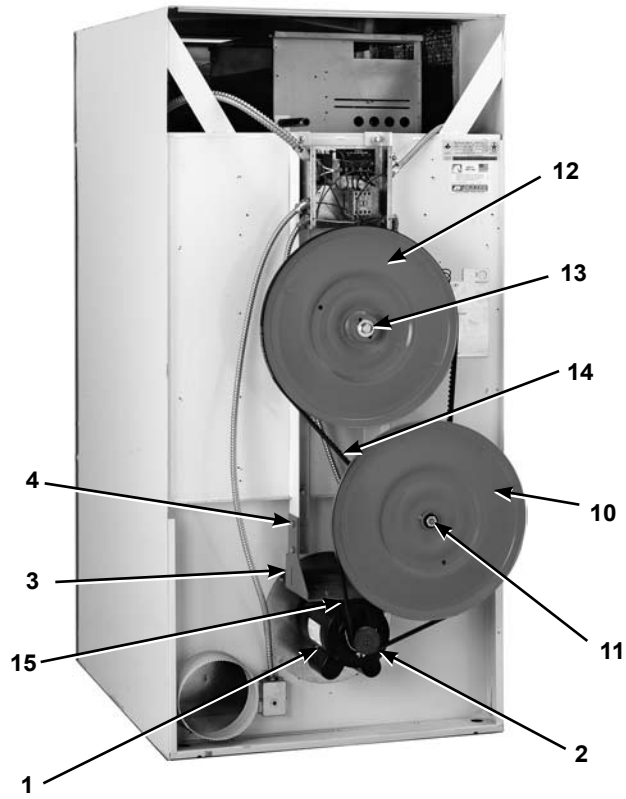

# Door Switch Group

Key	Part Number	Description	Quantity
1	9041-076-001	Box, Door Switch .....	1
2	9550-159-001	Shield, Door Switch .....	1
3	9539-461-007	Switch, Door .....	1
4	8640-401-001	Nut, Special Twin #4-40 .....	1
5	9545-020-001	Screw, Pn Hd Sl.#4-40x5/8 .....	2
6	9074-255-001	Cover, Switch Box.....	1
7	9545-008-020	Screw, Box Cover 10 AB x 3/4" .....	2
8	9008-004-001	Actuator, Switch.....	1
9	6068-041-001	Conduit Special .....	1
10	9545-012-003	Screw. 10-32 x 1/2" .....	1
*	8641-436-000	Washer, Fiber .....	1
11	8640-413-004	Nut, ElasticStop 10 -32.....	1

\* Not Illustrated

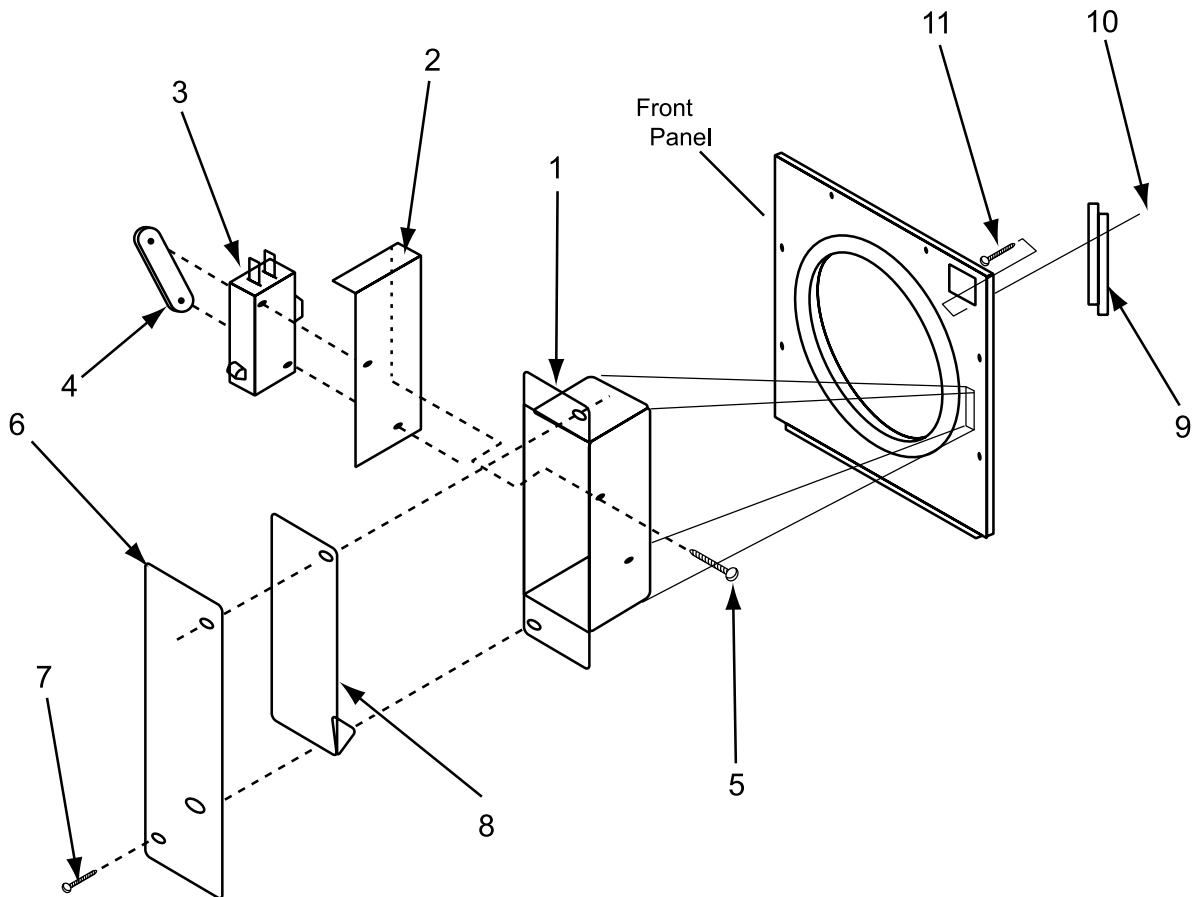

# Rear Control Group

Key	Part Number	Description	Quantity
1	9041-081-001	Box , Control.....	1
*	9074-304-001	Cover, Control Box Upper.....	1
*	9545-008-024	Screw 10AB x 3/8".....	4
2	5192-295-011	Relay (Large).....	1
*	9545-044-002	Screw, #8ABx 3/8.....	2
3	9897-035-001	Terminal Block Assembly, Power.....	1
4	9558-029-005	Strip , Terminal Marker.....	1
*	9545-045-002	Screw, #8ABx 3/8.....	2
*	9074-305-001	Cover control box lower.....	1
10	8639-621-007	Screw #10-32 x 1/2 GRN.....	1
*	8640-411-003	Nut Hexkeys #6-32.....	2
9	5192-285-001	Relay (Clear).....	1
11	8711-007-001	Transformer.....	1
*	9545-012-009	Screw--#10-32 x 1/2" Mount Transformer.....	2
*	8640-413-002	Nut Hexkeys #10-21 UNF Mount Transformer.....	2
*	9545-031-003	Screw #6Bx 3/8 Mount Small Relay.....	2
*	8220-063-018	Wire Assembly White 8".....	1
*	8220-001-230	Wire Assembly Black/Red 8 1/2".....	1
*	8220-001-231	Wire Assembly Black/Blue.....	1
*	8220-001-452	Wire Assembly White 12 1/4".....	1
*	8220-001-478	Wire Assembly Green 7".....	1
*	8220-067-001	Wire Assembly Black/Red 7 3/4".....	1
*	8220-067-002	Wire Assembly Black/Blue 7 3/4".....	1
12	9376-300-001	Motor.....	1

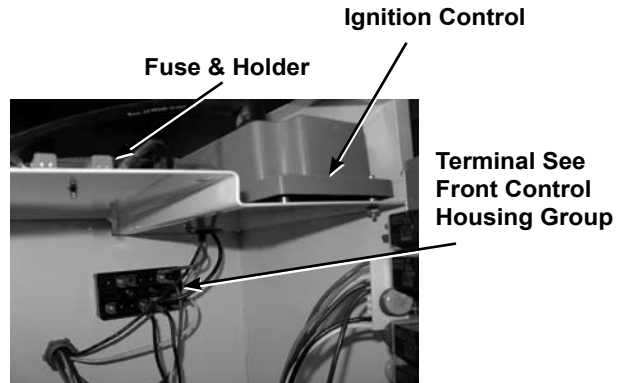
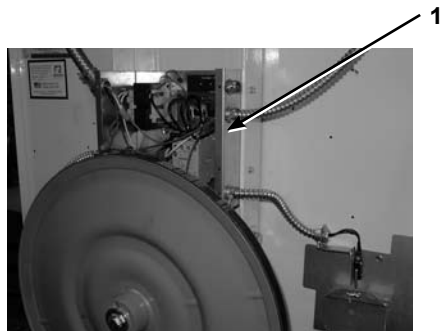
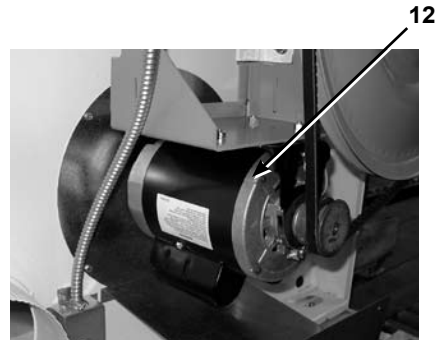
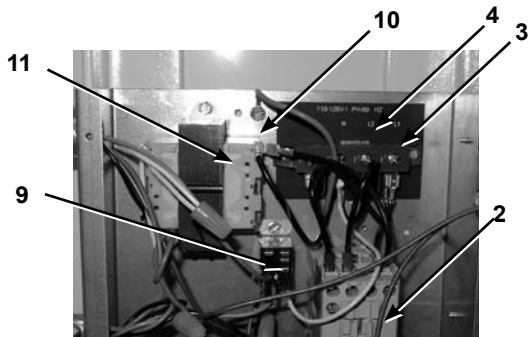

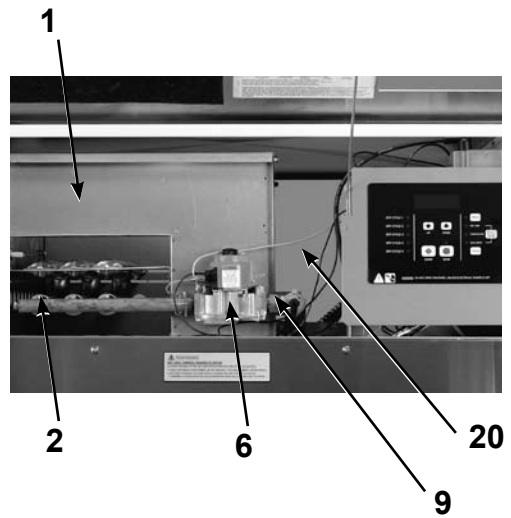
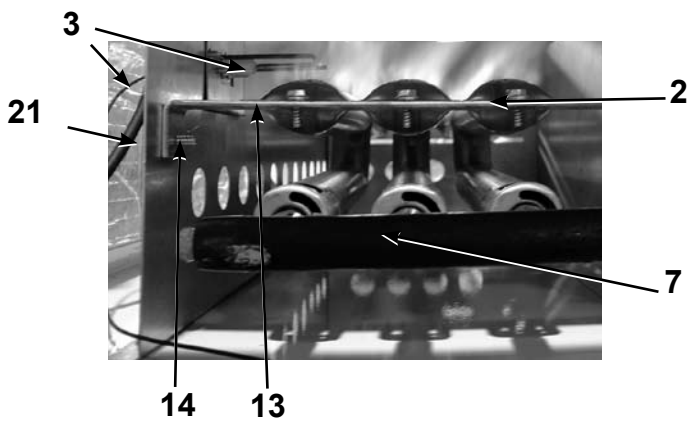
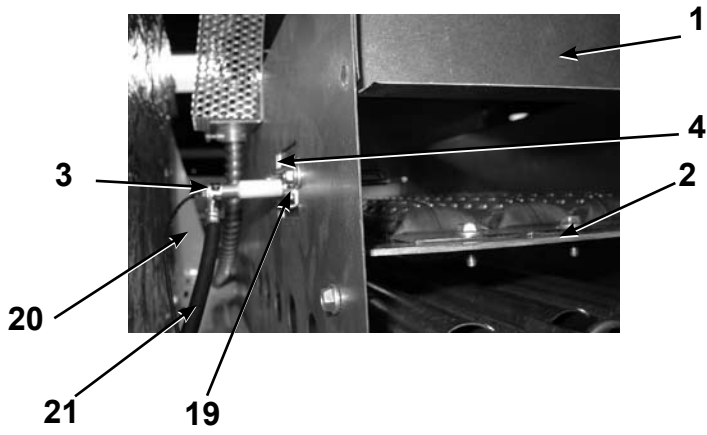
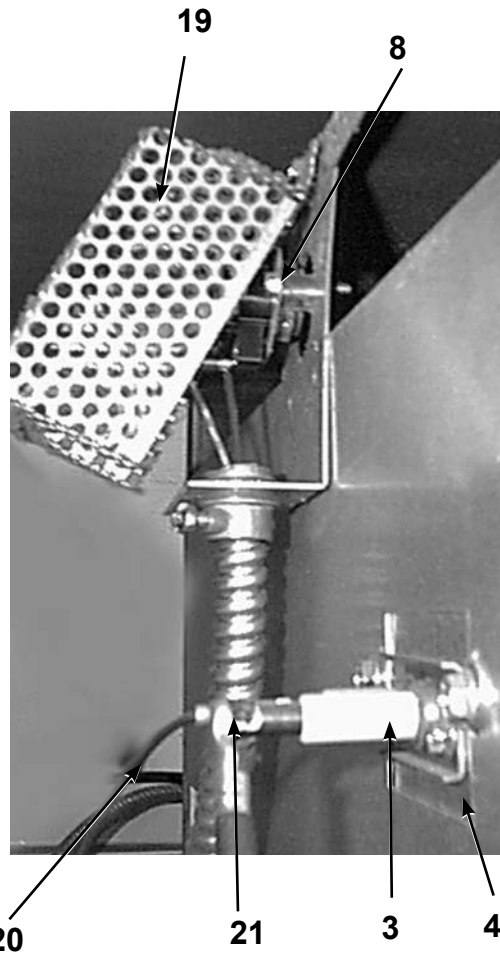



# Burner Housing Group

Key	Part Number	Description	Quantity
1	9803-196-001	Housing Assembly, Burner .....	1
*	9545-008-024	Screw .....	2
2	9048-018-001	Burner, Main .....	3
*	9545-008-008	Screw 8B x 1/14" .....	3
3	9875-002-002	Electrode, Ignition .....	1
4	9452-645-001	Plate, Electrode Mtg .....	1
*	9545-008-024	Screw, Electrode Mtg 8B x 10x 3/8" .....	2
6	9857-134-001	Control Assy, Gas .....	1
7	9381-010-001	Manifold, Assy 3 port .....	1
*	9425-069-021	Orifice, Burner-Natural .....	3
*	9425-069-022	Orifice, Burner-LP .....	3
8	9576-203-002	Thermostat, Hi-Limit .....	1
*	9538-142-001	Spacer, Hi-Limit .....	2
*	9545-045-007	Screw 8B x 3/4" .....	2
19	9074-234-001	Cover, Hi-Limit Stat .....	1
*	9545-008-024	Screw 10 B x 3/8" .....	1
*	9857-116-003	Control, Ignition (Gray Box) .....	1
*	9545-044-002	Screw 6-32 x 1" .....	2
*	8640-411-003	Nut, Hex Keps #6-32 .....	2
*	9897-026-001	Terminal Block Power (Inside Control Panel) .....	1
*	9545-031-004	Screw 6 AB x 5/8" .....	2
*	9039-915-001	BRACKET, Pipe gas line .....	1
*	9545-008-003	Screw 6AB x 5/8" .....	2
21	9631-403-003	Wire Ass'y, High Voltage .....	1
20	9627-711-001	Harness, Low Voltage Ignition .....	1
*	9054-045-001	Fuseholder .....	1
*	8636-018-001	Fuse 1.5 amps .....	1
*	8711-007-001	Transformer, Control (In rear control box) .....	1
*	9545-012-009	Screw, #10x1/2" .....	2
*	9732-102-010	Kit, LP Conversion .....	1
13	9548-280-001	Support, Front Burner .....	1
14	9545-008-008	Screw 10T-32 x 1/2" .....	3
*	9454-738-001	Left side burner housing .....	1
*	9454-572-001	Right side burner housing .....	1
9	9379-164-001	Valve, Gas Shut-Off w/ brass union .....	1
*	9458-020-003	Pipe, Gas Line .....	1
*	9454-737-001	Front Side Burner Housing .....	1

\* Not Illustrated

# Bearing Housing Group

Key	Part Number	Description	Quantity
*	9803-189-001	Housing, Bearing Ass'y w one( rear ) bearing .....	1
1	9241-183-003	Housing, Bearing .....	1
2	9036-159-001	Bearing, Ball-Rear .....	1
*	9036-159-002	Bearing, Ball-Front .....	1
3	8641-581-026	Washer, Flat 1/2" .....	4
4	8641-582-004	Lockwasher spring 1/2" .....	4
5	9545-017-004	Bolt, 1/2-13x1 .....	4
6	9545-059-003	Screw, 7/16-14x1 1/2.....	2
*	8641-582-013	Lockwasher, 7/16 .....	2
7	8640-416-001	Nut, 7/16-14.....	4

\* Not Illustrated

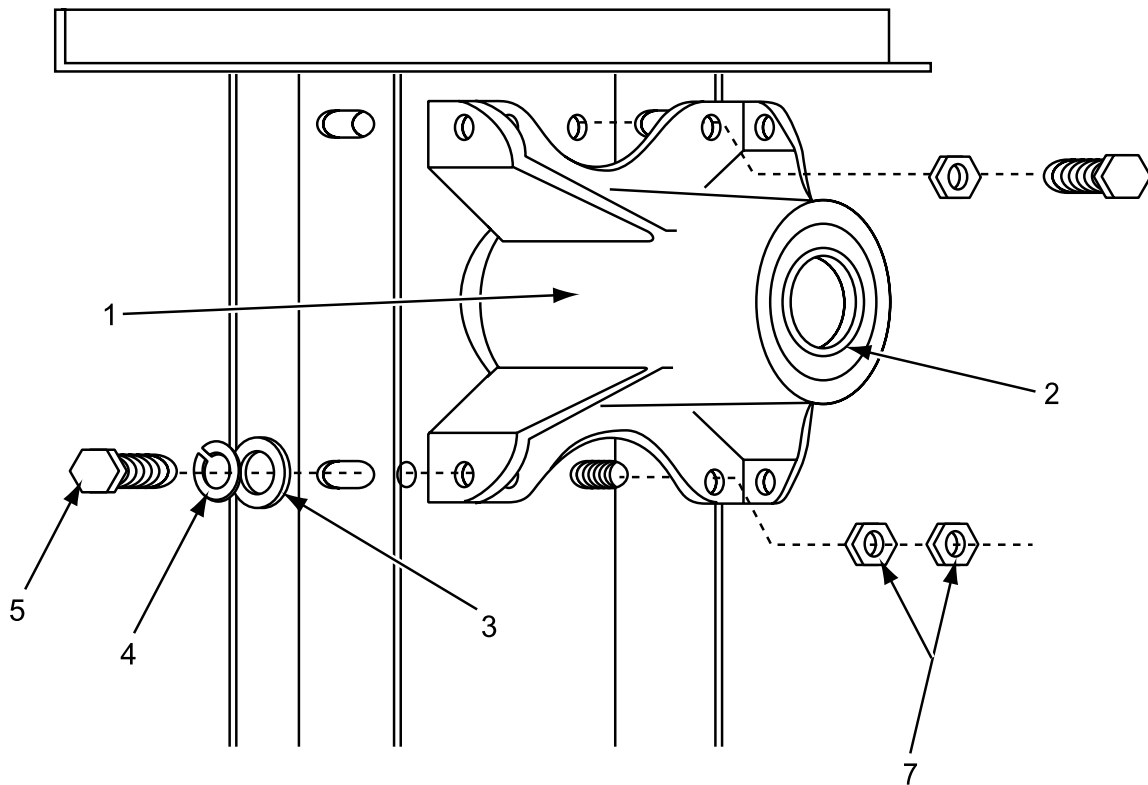

# Tumbler Basket Group

Key	Part Number	Description	Quantity
1	9848-132-001	Tumbler Ass'y .....	1
*	9848-132-002	Tumbler Ass'y, SS .....	1
2	9873-005-001	Spider Ass'y with bearing on .....	1
3	9497-226-001	Rod, Tumbler .....	4
4	8640-417-005	Nut 1/2" .....	4
5	9552-013-000	Shim .....	4
7	8641-590-002	Washer, Tumbler Rod Special .....	4
*	9487-234-001	Ring, Tolerance .....	1
8	8641-582-016	Lock Washer ext tooth 1/2", Tumbler Shaft .....	1
9	8641-581-026	Flat Washer 1/2", Tumbler Shaft .....	1
10	9545-017-009	Screw, Tumbler Shaft 1/2-13 x 11/4" .....	1

\* Not Illustrated

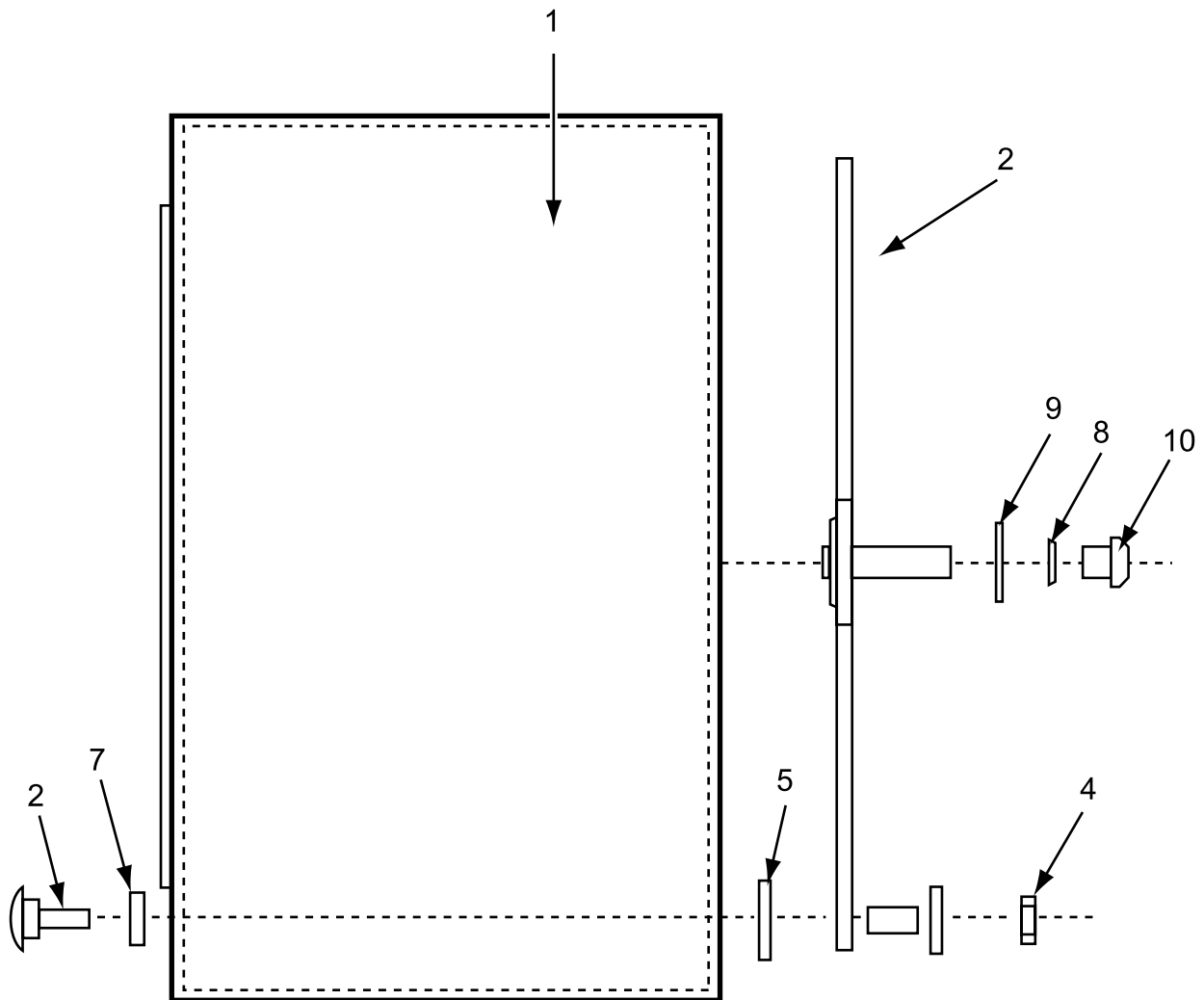

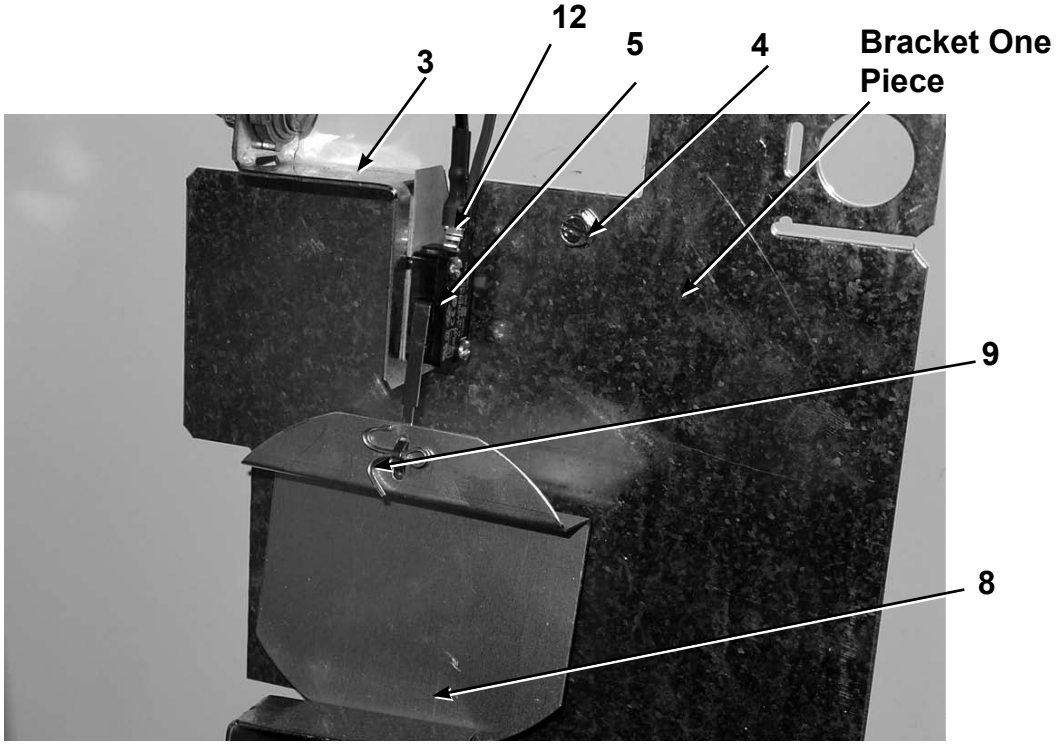
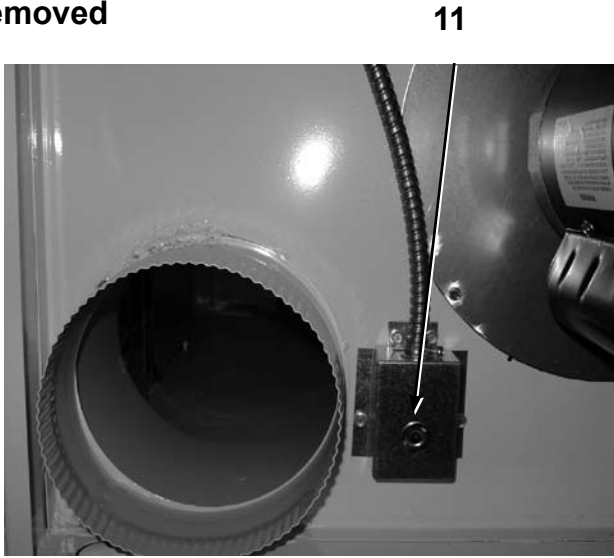
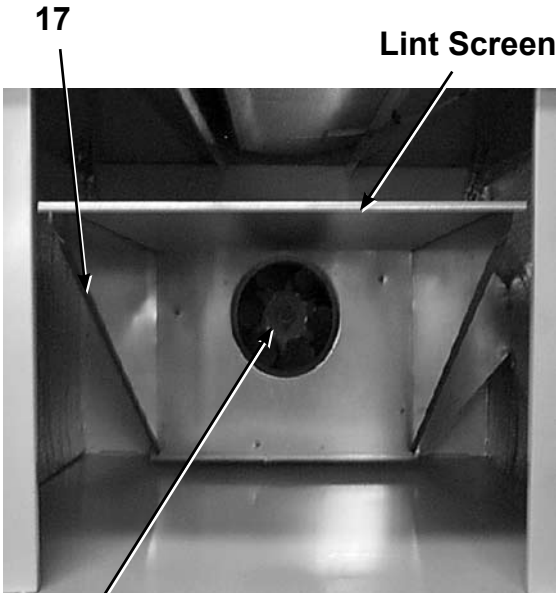

# Blower Impeller and Air Flow Switch Group Over Temperature Switch

Key	Part Number	Description	Quantity
3	9029-135-002	Bracket -Switch One Piece .....	1
4	9545-008-024	Screw-10B x 1/4 .....	2
5	9539-461-009	Switch-Micro .....	1
12	9545-020-001	Screw 4-40 x 5/8.....	2
*	8640-401-001	Nut Twin.....	1
8	9008-007-001	Actuator-Switch.....	1
9	9451-169-002	Pin Cotter.....	1
13	9039-575-000	Bracket Conduit .....	1
11	9825-057-002	Over-tempcoverass'y .....	1
*	9576-207-006	Thermostatover-tempMnl.....	1
*	9545-008-024	Screw 10B x 3/8.....	2
*	9550-169-003	Shield for macro switch.....	1
17	9834-010-001	Hood Ass'y, Lint .....	1
*	8640-412-004	Nut, Whizlock.....	6
*	9822-031-002	Lint Screen 34" length (newest style) .....	1
10	9278-038-004	Impeller, w/set screws.....	1

\* Not Illustrated

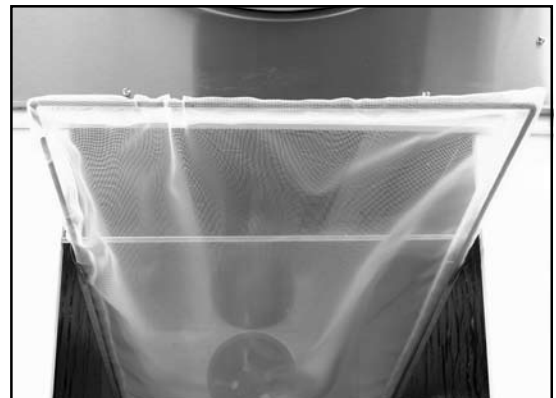

17

Lint Screen



# Wires & Harness Group

Key	Part Number	Description	Quantity
*	8220-001-486	BRN 26" Air Flow Switch.....	1
*	8220-001-499	BLK 26" Air Flow Switch.....	1
*	8220-101-002	BLK 64" Safety Thermostat.....	1
*	8220-103-003	Wire Assembly GRY 64" Safety Thermostat.....	1
*	8220-101-007	Wire Assembly VIO 54" Hi Limit Thermostat.....	1
*	8220-101-004	Wire Assembly BRN 54" Hi Limit Thermostat.....	1
*	2114-008-000	Bushing Anti Short.....	1
*	8220-001-480	Wire Assembly BLK 45" Door Switch.....	1
*	8220-001-479	Wire Assembly BLU 45" Door Switch.....	1
*	8220-001-461	Wire Assembly WHT 58".....	1
*	8220-062-007	Wire Assembly BLK 74".....	1
*	8220-064-012	Wire Assembly RED 61".....	1
*	8220-063-017	Wire Assembly GRY 64".....	1
*	8220-065-021	Wire Assembly VIO 61".....	1
*	8640-276-003	Wire Nut #73 B ORG.....	1
*	8220-060-001	Wire Assembly GRN 12".....	1
*	8220-063-018	Wire Assembly WHT 8" Control Box.....	1
*	8220-001-230	Wire Assembly BLK/RED 8.5" Control Box.....	1
*	8220-001-231	Wire Assembly BLK/BLU Control Box.....	1
*	8220-001-452	Wire Assembly WHT 12" - 4" Control Box.....	1
*	8220-001-478	Wire Assembly GRN 7" Control Box.....	1
*	8220-067-001	Wire Assembly BLK/RED 7 3/4" Control Box.....	1
*	8220-067-002	Wire Assembly BLK/BLU 7 3/4" Control Box.....	1
*	8220-001-466	Wire Assembly Yellow 4 7/8".....	1
*	9627-711-001	Low Voltage Harness.....	1
2	9637-403-003	High Voltage Harness.....	1
*	8220-001-290	Wire Assembly BLK.....	1
*	9627-679-002	Wire Harness Heat Sensor.....	1
*	8640-276-005	Wire Nut #71 Black Temp Sensor.....	2
*	8220-106-001	Wire Assy Red 59" - Motor.....	1
*	8220-106-002	Wire Assy White 59" - Motor.....	1
*	8220-103-004	Wire Assy Blue 59" - Motor.....	1

# Label Group

Key	Part Number	Description	Quantity
*	8507-256-001	Instructions Uncrating.....	1
*	8514-074-001	Owners Booklet.....	1
*	8507-350-001	Instructions Dry Install / Start-Up.....	1
*	8507-330-001	Instructions TVSS.....	1
*	9345-892-001	Wiring Schematic.....	1
*	9345-891-001	Wiring Diagram.....	1
*	8511-001-002	Label Quality.....	1
*	8502-658-001	Label Fire Hazard.....	1
*	8527-115-001	Label Decal Lighting and Clearance.....	1
*	8502-645-001	Label Instructions.....	1
*	8502-600-001	Label Warning and Notice.....	1

# Rear Guard Group

Key	Part Number	Description	
1	9208-066-001	Drive Guard.....	1
2	9454-692-001	Right Side Panel Drive Guard.....	1
3	9454-693-001	Left Side Panel Drive Guard .....	1
4	9550-175-001	Motor Shield.....	1
*	9545-008-003	Screw 10-16 x 1/2 TEK .....	2
*	9545-008-001	Screw 10 B x 1/4.....	11

\* Not Illustrated

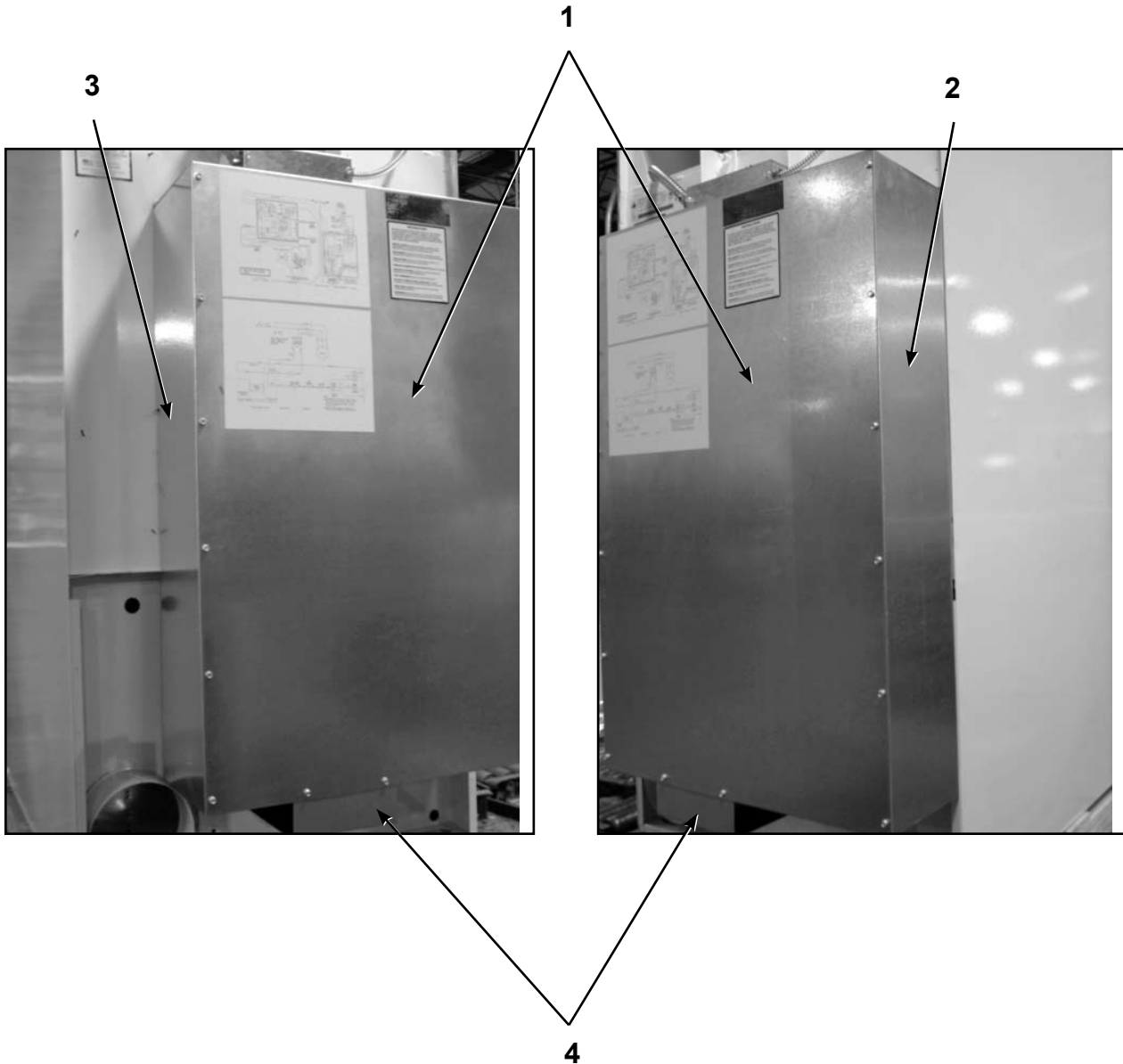



# Electric Heated Dryers Electrical Parts All Types of KW

## DCWD 55H\_\_ 18 FD 240/60/3 24 KW

Key	Part Number	Description	Quantity
*	5192-296-001	Relay .....	1
*	5198-213-001	Circuit Breaker 3 Pack .....	2
*	8220-057-016	Wire Assembly Blk .....	3
*	9345-969-001	Schematic .....	1
*	9345-970-001	Diagram.....	1
*	9870-088-004	Heater Elements 12 KW 240 V .....	2
*	5192-285-004	Relay .....	1
*	9377-003-001	Variator Coil Supply .....	1
*	8502-711-001	Warning Label 208V.....	1
*	8220-057-004	Wire Brown 30" .....	1
*	8220-057-007	Wire White/Black 45" .....	1
*	8220-057-008	Wire Black 45" .....	1
*	8220-057-011	Wire V10 32" .....	1
*	8220-057-015	Wire Black 8" .....	6
*	8220-057-019	Wire White 8" .....	1
*	8220-061-008	Wire Black 36" .....	4
*	8220-061-010	Wire Black 48" .....	2
*	8220-078-008	Wire Black 9" .....	2
*	8220-078-011	Wire White 45" .....	1
*	8220-078-012	Wire Red 45" .....	1
*	8502-614-004	Label High Voltage.....	1
*	8502-708-001	Label Exhaust Warning.....	1
*	8514-091-001	Owners Book .....	1
*	9029-127-001	Guard Bracket Mounting .....	1
*	9208-053-001	Guard Front Cabinet Cover .....	1
*	9208-054-001	Guard Rear Cabinet Cover .....	1
*	9074-289-001	Cover Plate Control Box.....	1
*	9210-117-001	Gussett Control Box.....	1
*	9548-282-001	Support Wire .....	2
*	9074-288-001	Cover Plater Heater.....	1
*	9636-151-001	Wrapper Heat Housing RH .....	1
*	9636-152-001	Wrapper Heat Housing LH .....	1
*	9550-181-001	Shield Side Heathousing.....	2
*	9577-056-001	Top Heater Housing Half.....	2
*	9053-067-001	Bushing Insulated 3/4" .....	6
*	9577-057-001	Top Box Control .....	1
*	9636-153-001	Wrapper Box Control.....	1
*	9058-025-001	Bottom Box Control.....	1
*	9053-067-004	Bottom Bushing Insulated .....	2
*	9295-004-001	Formed Jumper.....	2
*	9295-005-001	Straight Jumper.....	4
*	9488-010-003	Din Rail 4 3/4" .....	1
*	9897-037-001	Power Block 3 Pole .....	1
*	9897-038-001	Power Block 1 Pole .....	1
*	9209-087-001	Grommet .....	1
*	8640-399-004	Nut Spring .....	1
*	8640-399-009	Nut Spring U Type .....	4
*	8502-639-001	Label Warning .....	1
*	8502-702-001	Label Warning Fire Hazard (French).....	1
*	8652-134-002	Terminal Lug Solderless .....	1

## Electric Heated Parts Model Specific

### DCWD 55H\_\_ 16 FC 208/60/3 24 KW

Key	Part Number	Description	Quantity
*	5198-213-002	Circuit Breaker 3 Pole .....	2
*	5192-296-001	Relay, Heating Element.....	1
*	8220-057-016	Wire Assembly Blk 8" .....	3
*	9870-088-005	Heater Elements 12 KW 208 V .....	2
*	9345-967-001	Schematic .....	1
*	9348-968-001	Diagram.....	1

### DCWD 55H\_\_ 16 FE 208/60/3 30 KW

Key	Part Number	Description	Quantity
*	9345-971-001	Schematic .....	1
*	9345-972-001	Diagram.....	1
*	5198-213-004	Circuit Breaker 3 Pole .....	2
*	5192-294-001	Relay, Heating Element.....	1
*	8220-057-014	Wire Assembly Black 8" .....	3
*	9870-088-001	Heater Elements 15 KW 208 V .....	2

### DCWD 55H\_\_ 18 FG 240/60/3 30 KW

Key	Part Number	Description	Quantity
*	5192-294-001	Relay, Heating Element.....	1
*	5198-213-003	Circuit Breaker 3 pole.....	2
*	8220-057-014	Wire Assembly Black 8" .....	3
*	9345-973-001	Schematic .....	1
*	9345-974-001	Diagram.....	1
*	9870-088-002	Heater Element 15KW 240 V .....	2

## Steam Heated Parts Model Specific

### DCWD 55H\_\_ 10 FS

Key	Part Number	Description	Quantity
*	9799-021-001	Steam PCB Assembly Micro .....	1
*	9805-031-001	Lint Screen Assembly Intake.....	1
*	9506-032-001	Wire Diagram .....	1
*	9506-031-001	Wire Schematic.....	1
*	9488-012-001	Rail Lint Screen Intake .....	1
*	9379-193-001	Steam Valve Solenoid .....	1
*	9242-465-001	Braided Steam Hose Stainless .....	2
*	9089-048-001	Coil Steam Heating .....	1
*	8514-080-001	Owners Manual .....	1
*	8502-717-001	Label Lint Screen .....	1
*	8220-078-017	Wire Assembly White 7" .....	1
*	8220-078-016	Wire Assembly Red 7" .....	1
*	8220-067-002	Wire Assembly Black/Blue 7 3/4" .....	2
*	8220-064-037	Wire Assembly Green 40" .....	1
*	8220-063-010	Wire Assembly Black/Red 7" .....	1
*	5192-285-004	Relay .....	1

---

# **Section 7:**

## **Electric Heated & Steam Heated Wiring Diagrams & Informatives**

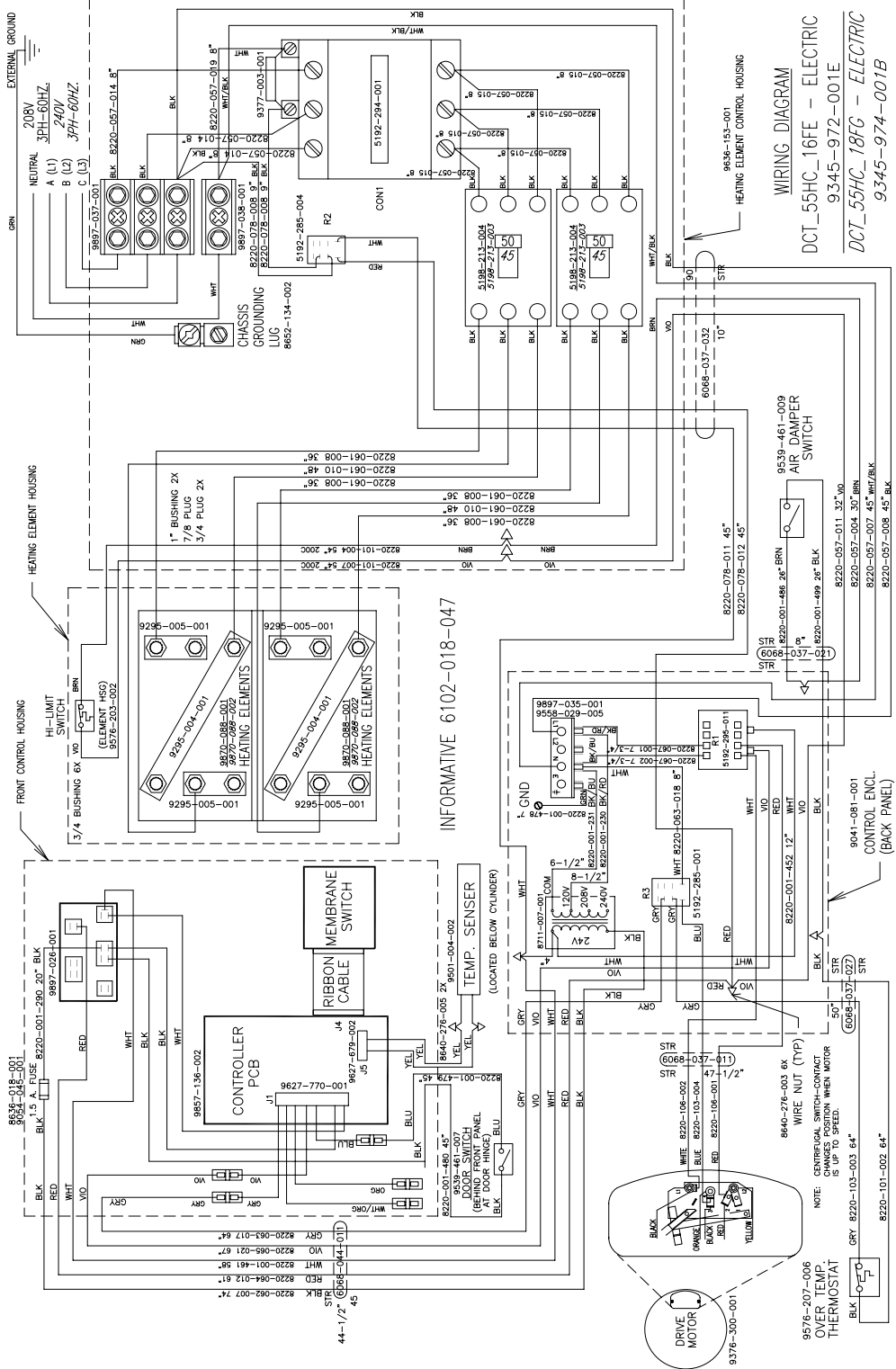

INFORMATIVE 6102-018-047

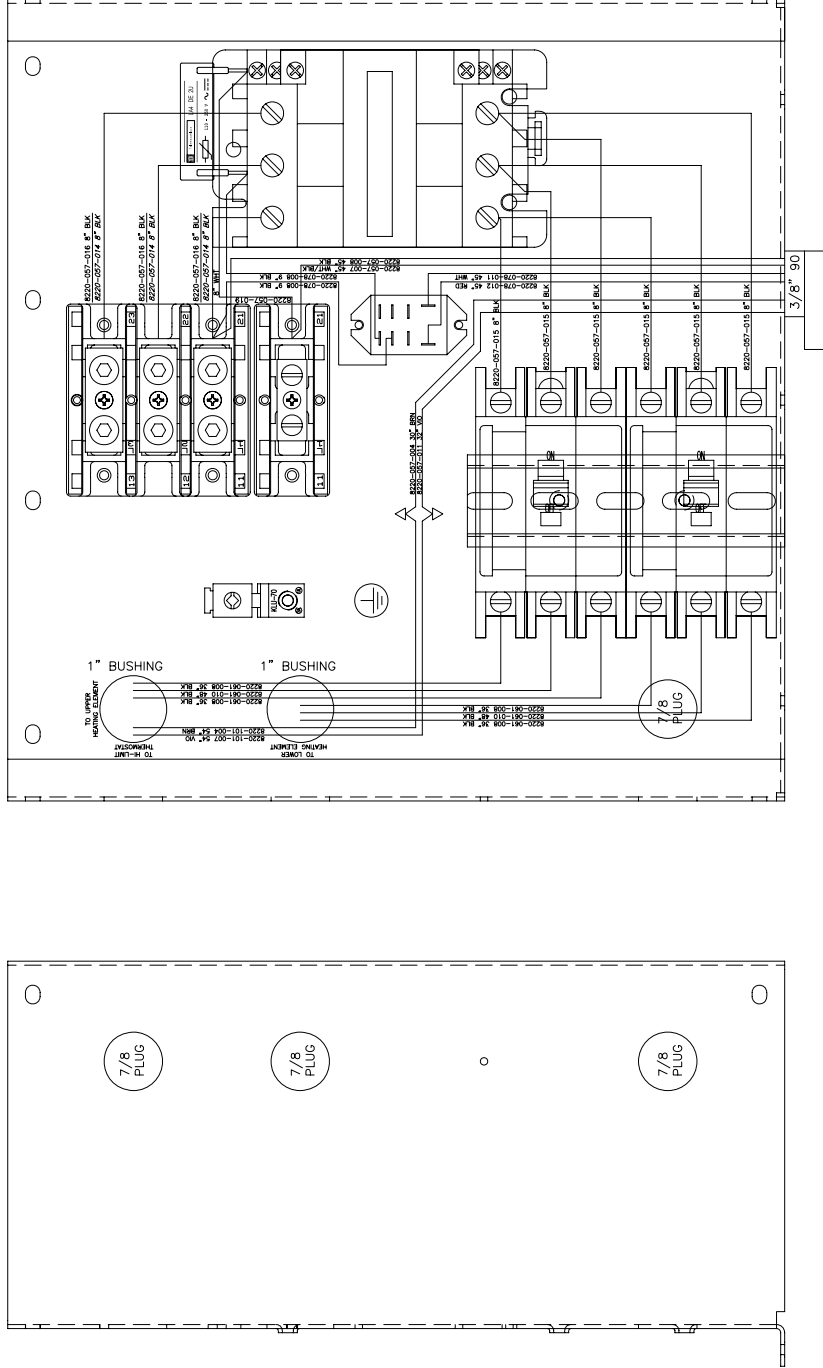

INFORMATIVE 6102-018-058  
 9636-153-001B ELECTRIC BOX DCT\_55HC\_1(6,8)F(C,D) - ELECTRIC  
 ELECTRIC BOX DCT\_55HC\_1(6,8)F(E,G) - ELECTRIC

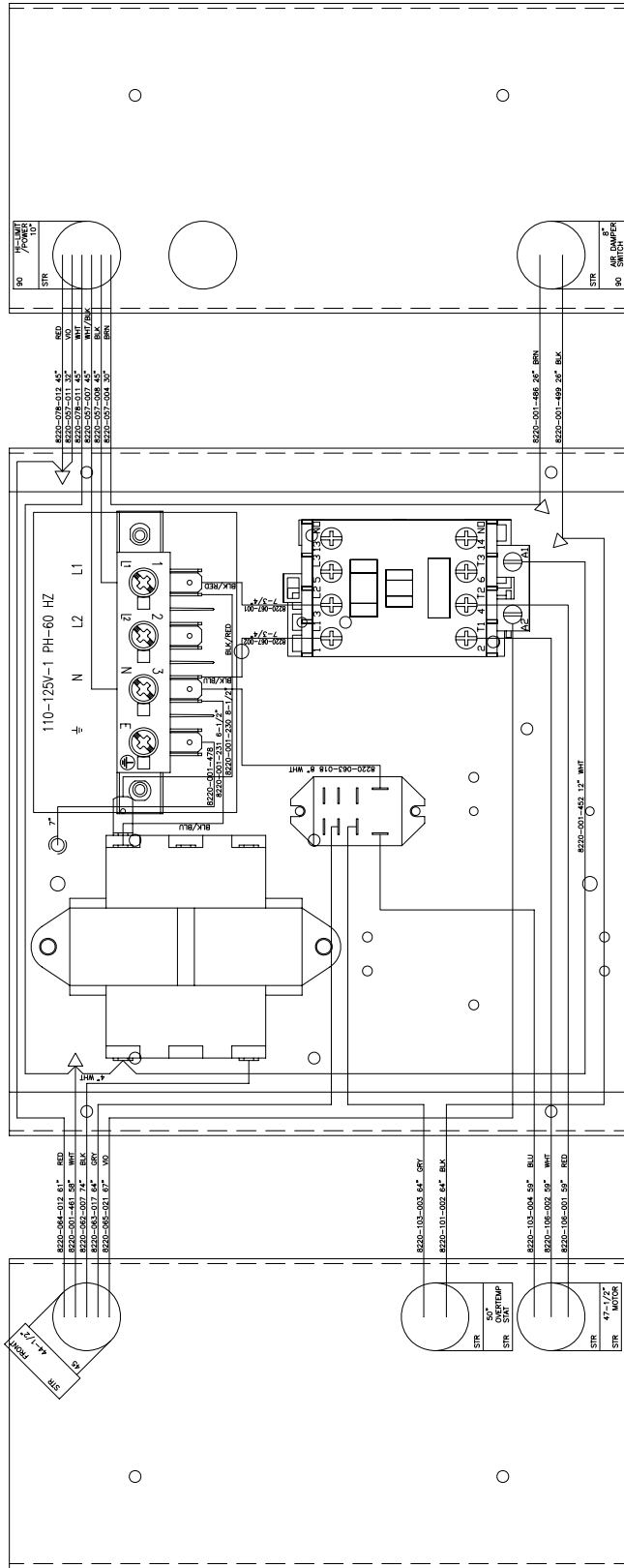

DCT\_55HC\_1(6,8)F(C,D) — ELECTRIC  
 DCT\_55HC\_1(6,8)F(E,G) — ELECTRIC

SAMPLE BOX

INFORMATIVE 6102-018-057

9041-081-001H



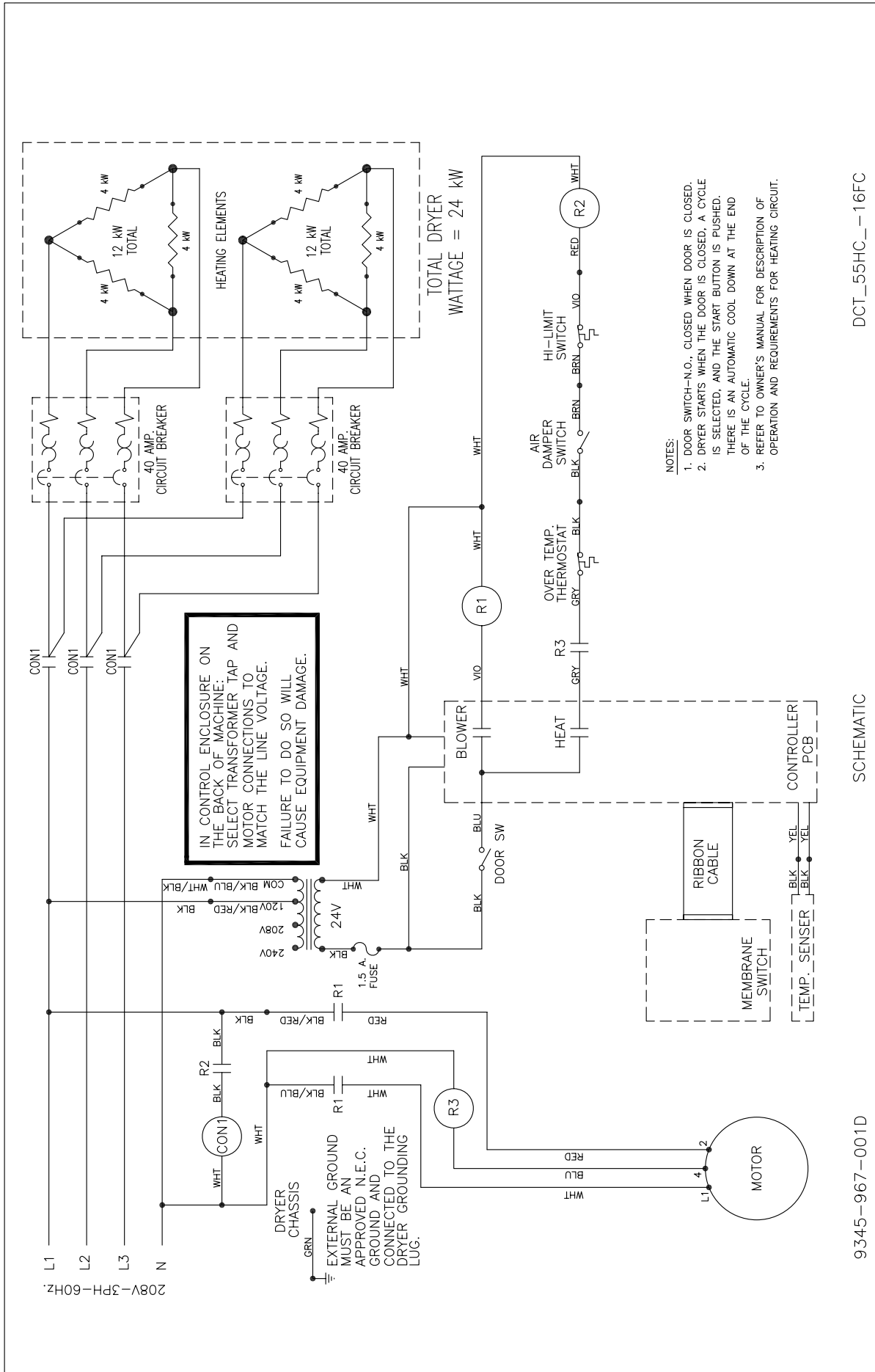

- NOTES:
1. DOOR SWITCH-N.O., CLOSED WHEN DOOR IS CLOSED.
  2. DRYER STARTS WHEN THE DOOR IS CLOSED, A CYCLE IS SELECTED, AND THE START BUTTON IS PUSHED. THERE IS AN AUTOMATIC COOL DOWN AT THE END OF THE CYCLE.
  3. REFER TO OWNER'S MANUAL FOR DESCRIPTION OF OPERATION AND REQUIREMENTS FOR HEATING CIRCUIT.

DCT\_55HC\_-16FC

SCHEMATIC

9345-967-001D



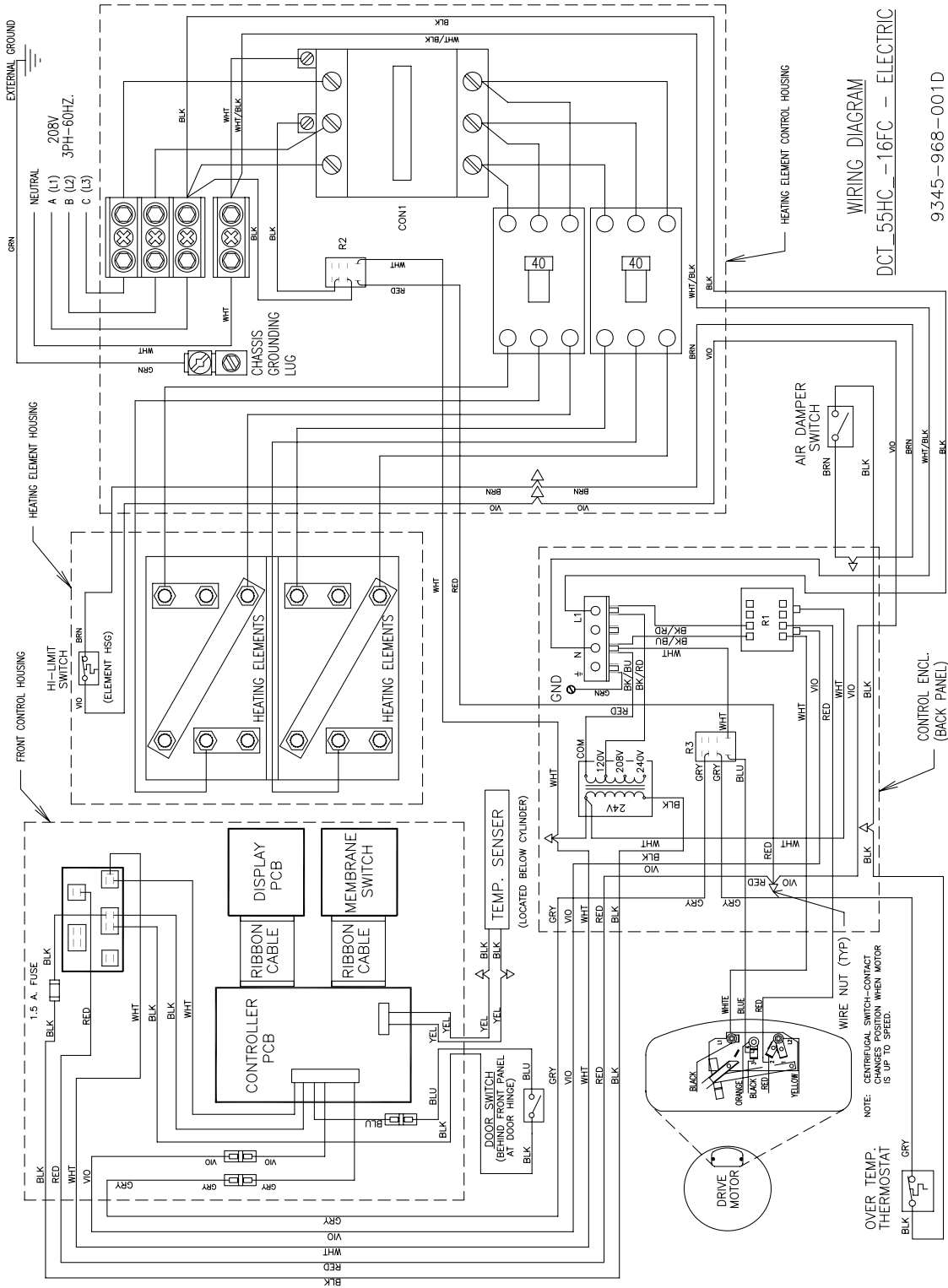



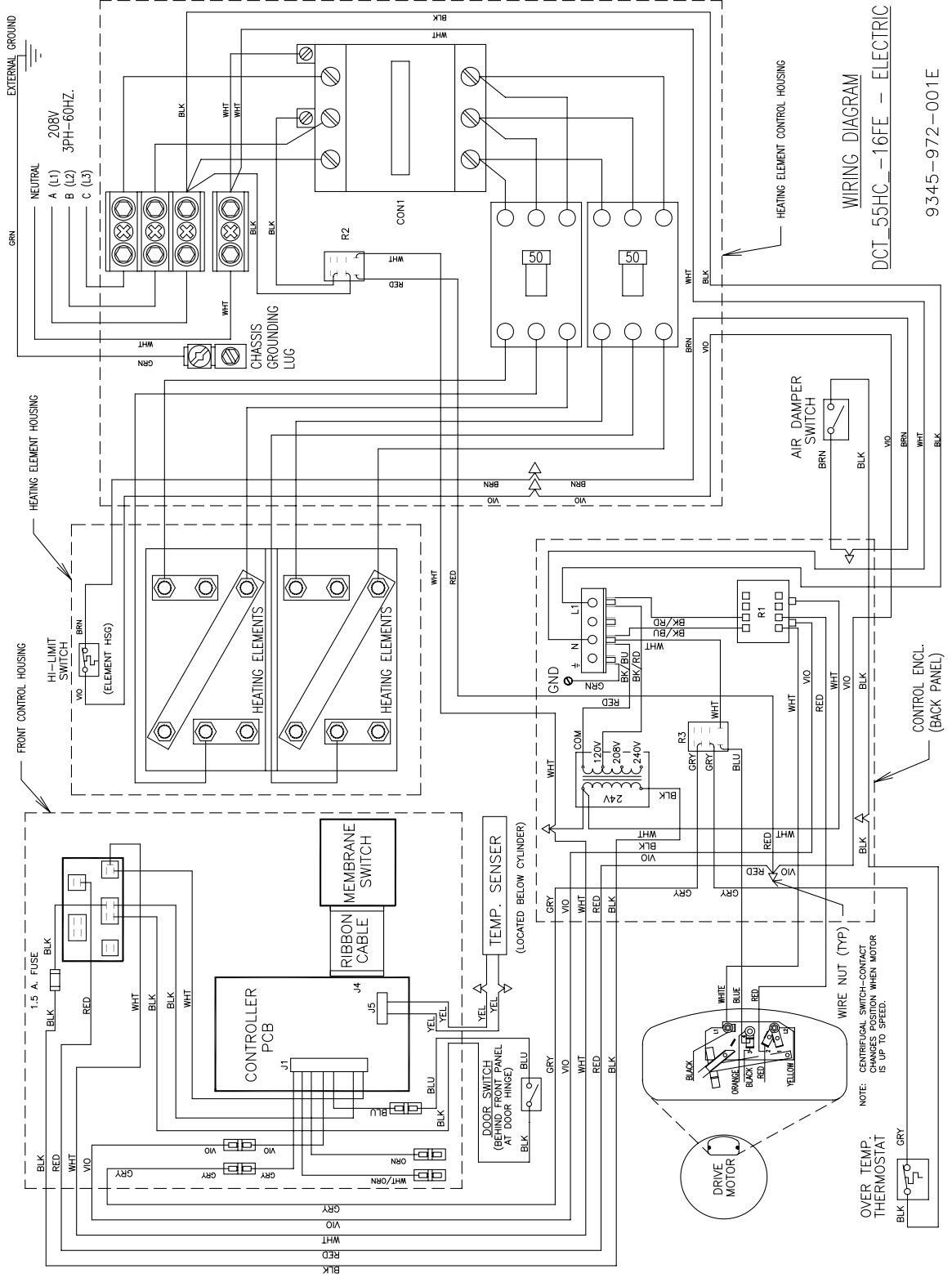

WIRING DIAGRAM  
DCI\_55HC - 16FE - ELECTRIC

9345-972-001E

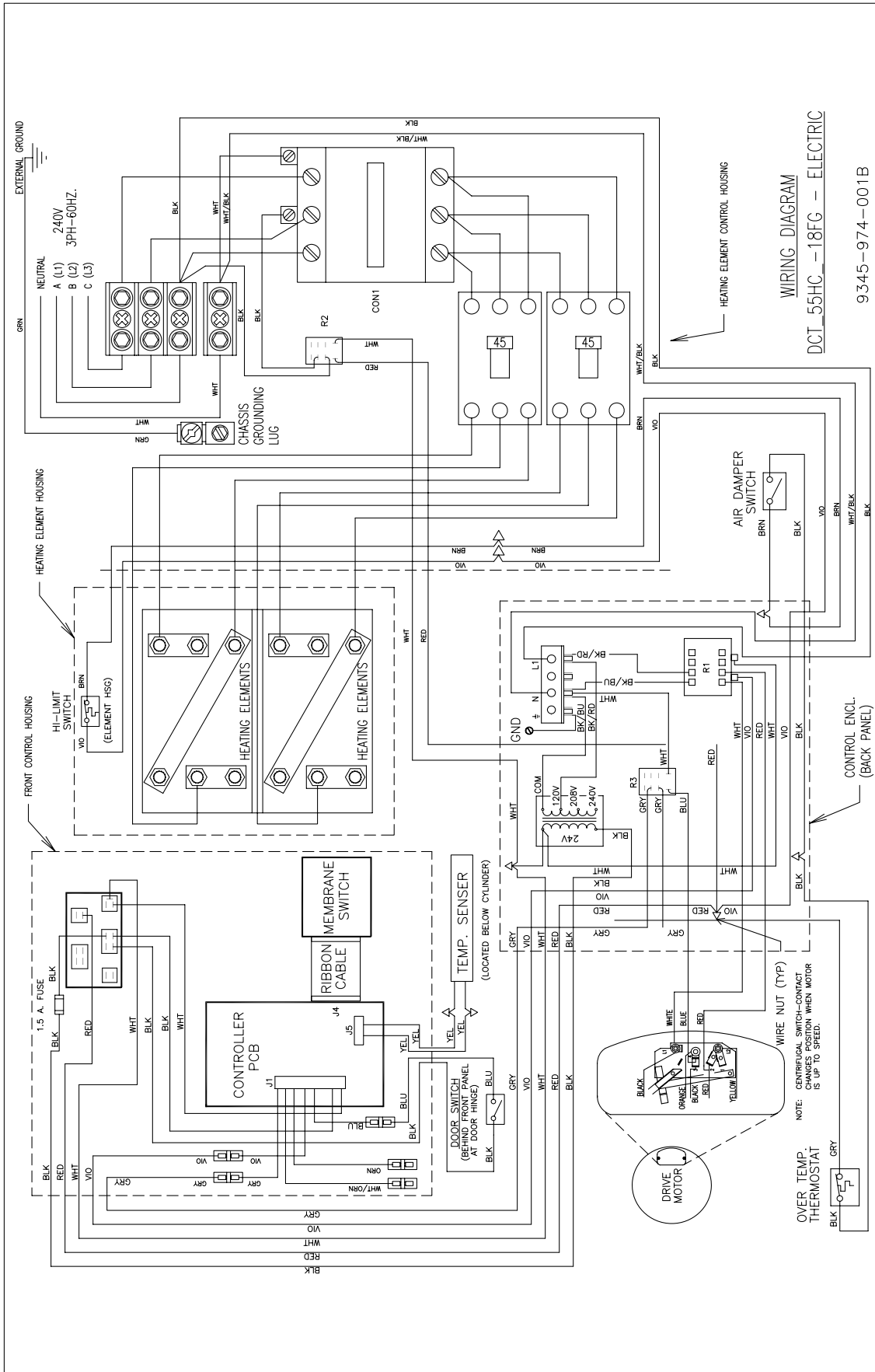

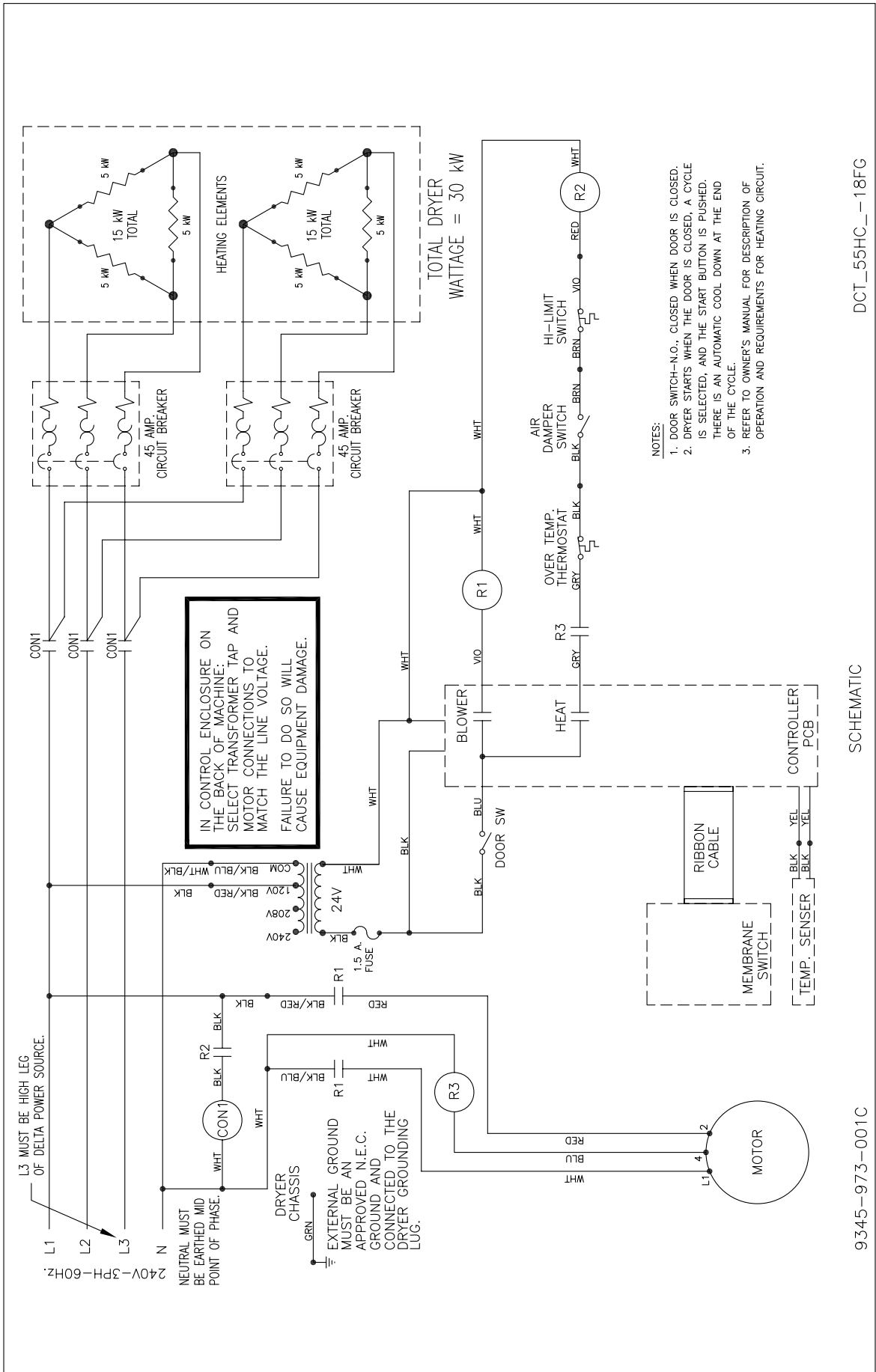

DCT\_55HC\_--18FG

SCHEMATIC

9345--973--001C



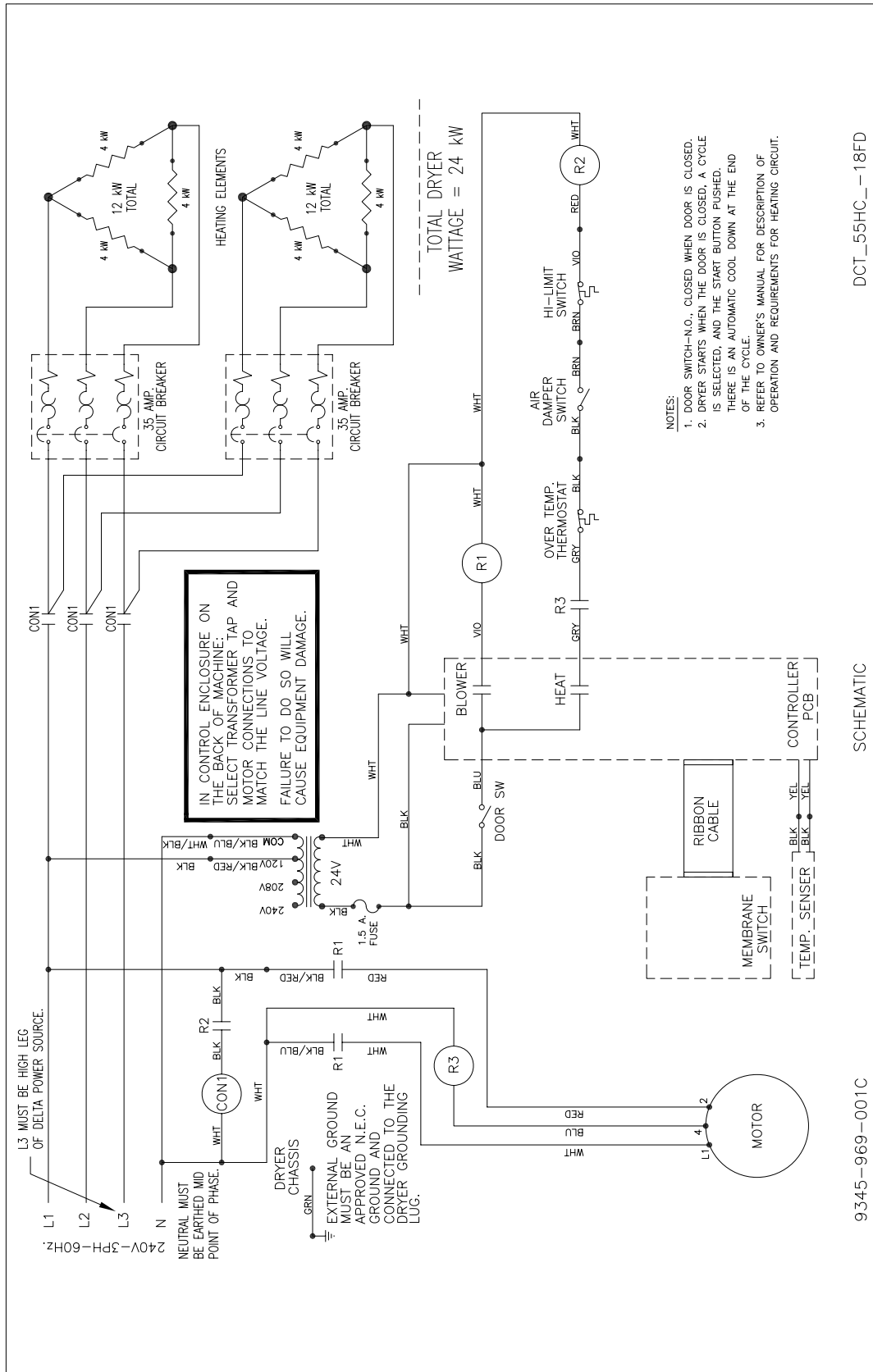

DCT\_55HC\_18FD

SCHEMATIC

9345-969-001C

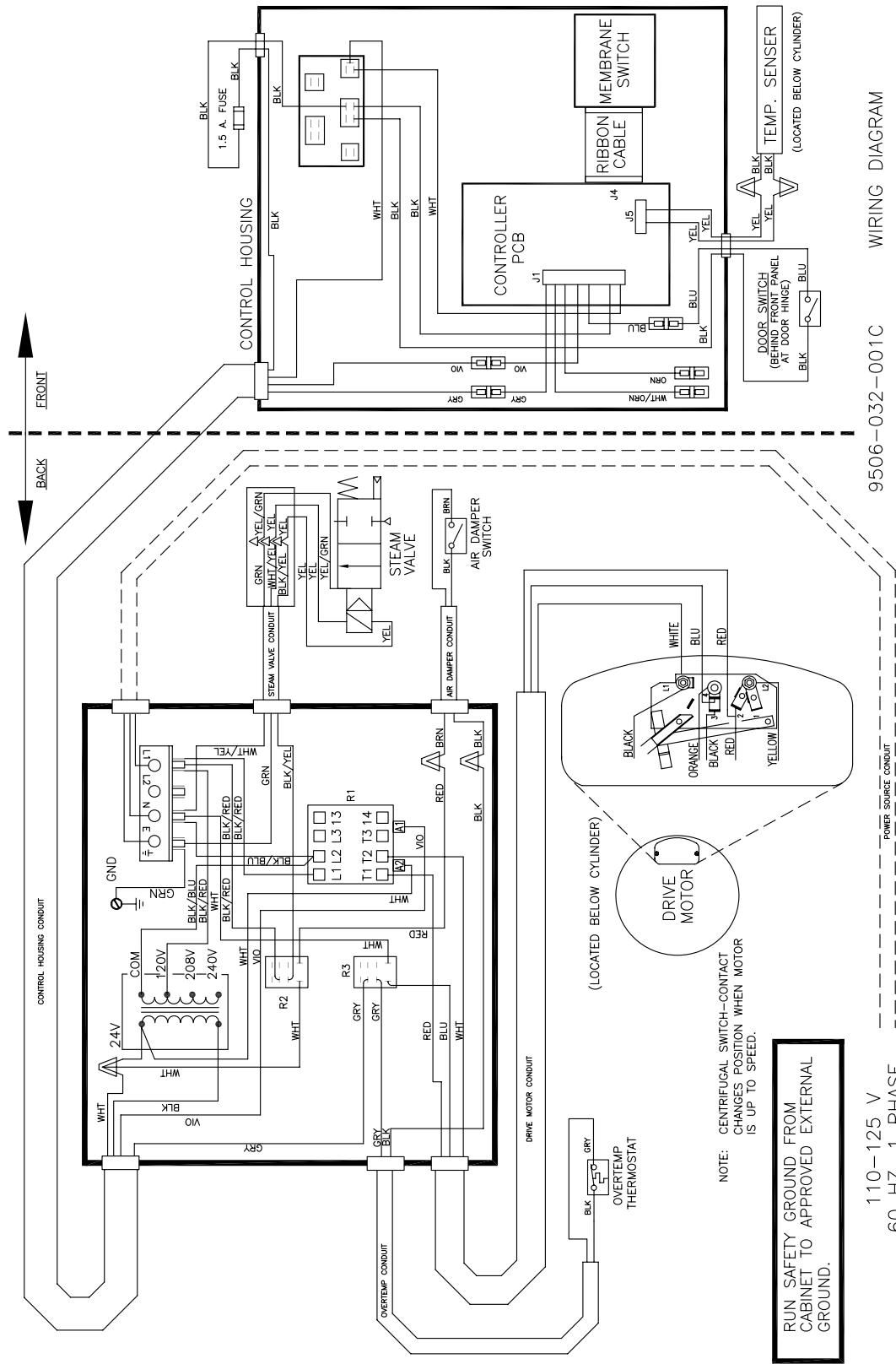

9506-032-001C WIRING DIAGRAM



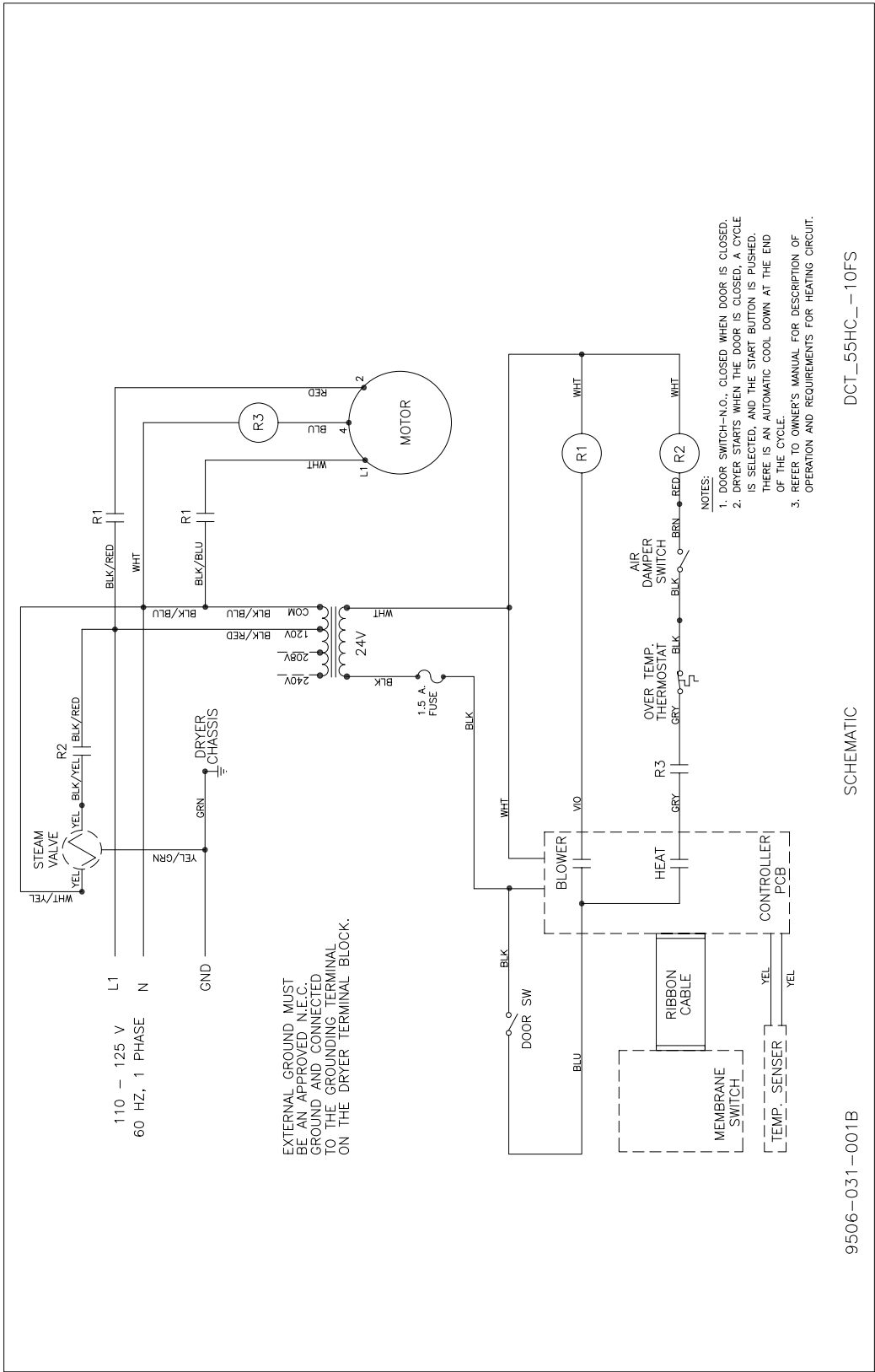

DCT\_55HC\_-10FS

SCHEMATIC

9506-031-001B



---

# **Section 8:**

**50hZ**

**Parts Data**

---

# Notes

---

# Model DCWD55HC\_59 50Hz

w/ Microprocessor Control Gas Heat Source

## Capacity

Dry Weight Capacity	55 lbs	24.8 kg
Cylinder Diameter	32.5"	82.55 cm
Cylinder Depth	38"	96.52 cm
Cylinder Volume	18.2 cu ft	516.5 dm <sup>3</sup>

## Dimensions

Cabinet Height (with feet)- Minimum	72.25"	183.52 cm
Cabinet Height (with feet)- Maximum	73.25"	186.06 cm
Cabinet Width	34.4375"	87.47 cm
Overall Depth	51.125"	129.86 cm
Floor to Door Bottom	29.5"	74.93 cm
Door Opening	22.6875"	57.63 cm

## Electrical

Electrical Phase	Single
Electrical Voltage (50 Hz)	220 - 240 V
Electrical Running Amps (50 Hz)	5
Circuit Protection (50 Hz)	10 AMP
Electrical Wire Size	12 Gauge
Electrical Service (Single Phase)	2 wire + ground
Motor Size	.56 kW
Tumble Direction	Counter Clockwise
Tumble Speed	47 RPM

## Gas Heat

Gas Input/Hour	160,000 BTU	,320 kcal
Gas Supply Connection (NPT)	1/2"	12.7 mm
Natural Gas Supply (Water Column)	5 -10"	12.7 - 25.4 cm
L.P. Supply (Water Column)	11.0 -13.5"	27.9 - 34.29 cm

## Installation

Air Flow	910 CFM	25.77 M <sup>3</sup> /min
Exhaust Size (Vent Diameter)	8"	20.32 cm
Make-Up Air (Minimum)	1.25 ft <sup>2</sup>	.12 m <sup>2</sup>
Net Weight	581 lbs	262 kg
Clearance Behind Machines (Minimum)	18"	45.72 cm

## DCWD 55HC--59 Electrical Components 50Hz

Key	Part Number	Description	Quantity	
1	5192-295-010	Relay.....	1	
	8220-001-282	Wire Assembly-RED, 20" .....	1	
	8220-001-462	Wire Assembly-VIO, 58" .....	2	
	8220-001-524	Wire Assembly-BLK, 46" .....	1	
	8220-001-530	Wire Assembly-BLK, 67" .....	1	
	8220-001-531	Wire Assembly Jumper-WHT, 12"-4".....	1	
	8220-065-006	Wire Assembly-BLK/RED, 11" .....	1	
	8220-065-007	Wire Assembly-BLK/BLU, 11" .....	1	
	8220-068-002	Wire Assembly-BLK/RED, 7" .....	1	
	8220-068-003	Wire Assembly-BLK/BLU, 5" .....	1	
	8220-088-002	Wire Assembly-BLK, 5" .....	1	
	8220-097-002	Wire Assembly-Jumper, BRN.....	1	
	8220-098-003	Wire Assembly-Jumper, YEL.....	1	
	8220-101-005	Wire Assembly-GRY, 64" .....	1	
	8220-101-010	Wire Assembly-YEL/BLK, 62" .....	1	
	8220-101-011	Wire Assembly-YEL, 62" .....	1	
	8636-018-004	Fuse 2.5A .....	1	
	8640-276-003	Nut-Wire Connection, #73B, ORG .....	1	
	2	8711-008-002	Transformer-Control .....	1
		9544-041-002	Strap-beaded Tie.....	2
9029-135-003		Bracket-Switch, Airflow.....	1	
3	9558-029-004	Strip-Marker, Terminal .....	1	
4	9183-030-001	Filter-Line, EMI .....	1	
5	9376-299-003	Motor-Dryer, A.O. Smith .....	1	
6	9453-169-011	Pulley-Drive, Motor .....	1	
8	9631-403-005	Wire Assembly-High Voltage.....	1	
9	9857-140-001	Control Assembly, Ignition .....	1	
	8502-680-001	Label-CE Rotation .....	1	
	8502-684-002	Label-European Information.....	1	
	8507-230-003	Instructions-Transformer Connect .....	1	
	8514-027-005	Booklet-Owners .....	1	
	9506-252-001	Wiring-Label, Schematic .....	1	
	9506-253-001	Wiring-Label, Diagram .....	1	

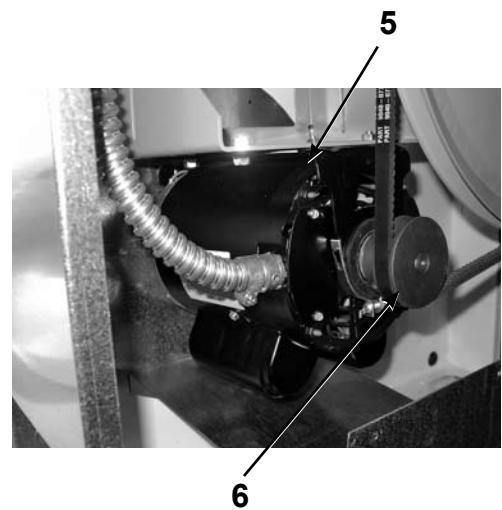
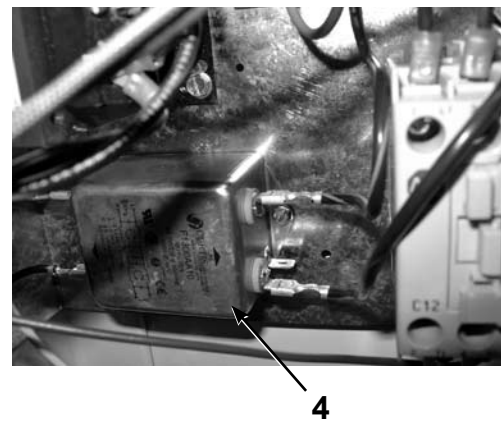
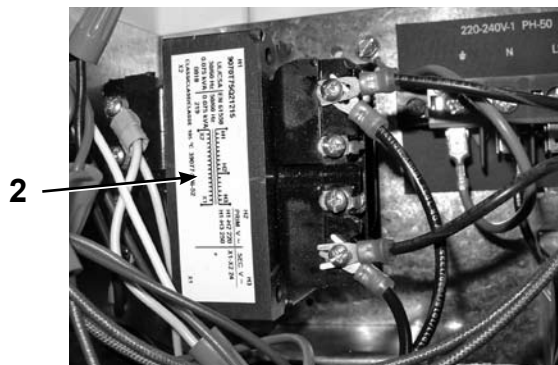
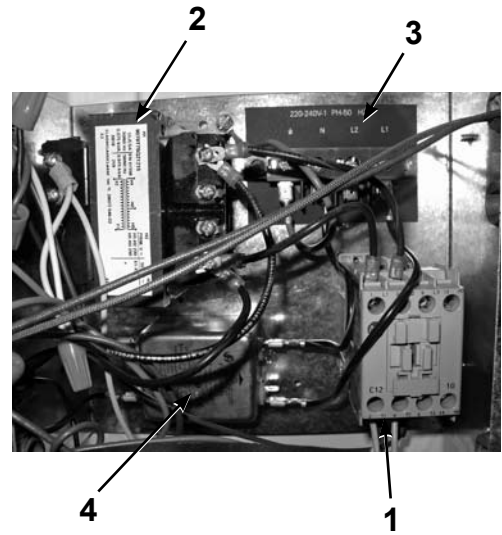
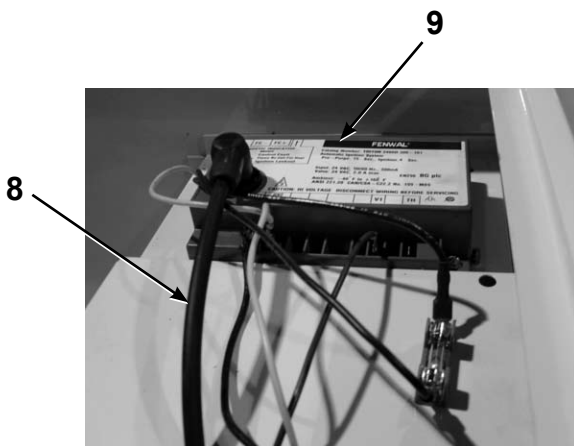

## Burner Housing And Gas Valve Parts 50Hz.

Key	Part Number	Description	Quantity
	9803-163-003	Burner Housing Assembly (Welded) .....	1
	9985-161-001	Bracket Assembly-Electrode Mounting .....	1
1	9381-009-005	Manifold Assembly 2 Port).....	1
	9425-069-020	Orfice-Plug, Main Burner, 3.9mm.....	2
2	9857-132-004	Valve Assembly-Gas .....	1
3	9732-162-001	Kit-VR86 Valve Flange .....	2
	9791-001-002	Adaptor Assembly-Gas inlet.....	1
	9000-043-001	Adaptor-3/4US to 3/4ISO Thred.....	1
	9000-044-002	Adaptor European Exhaust .....	1

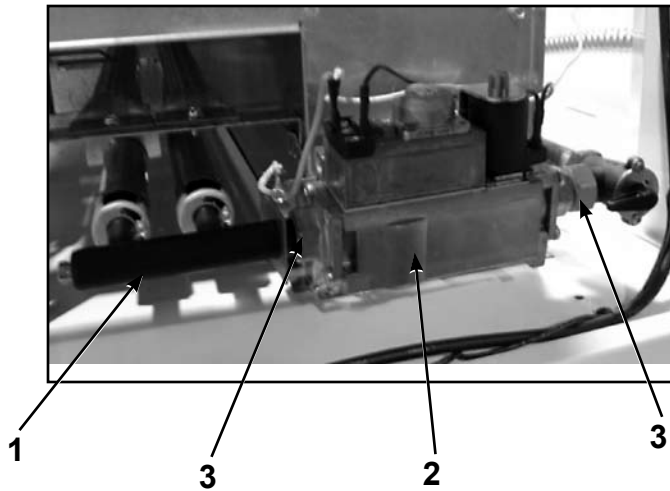



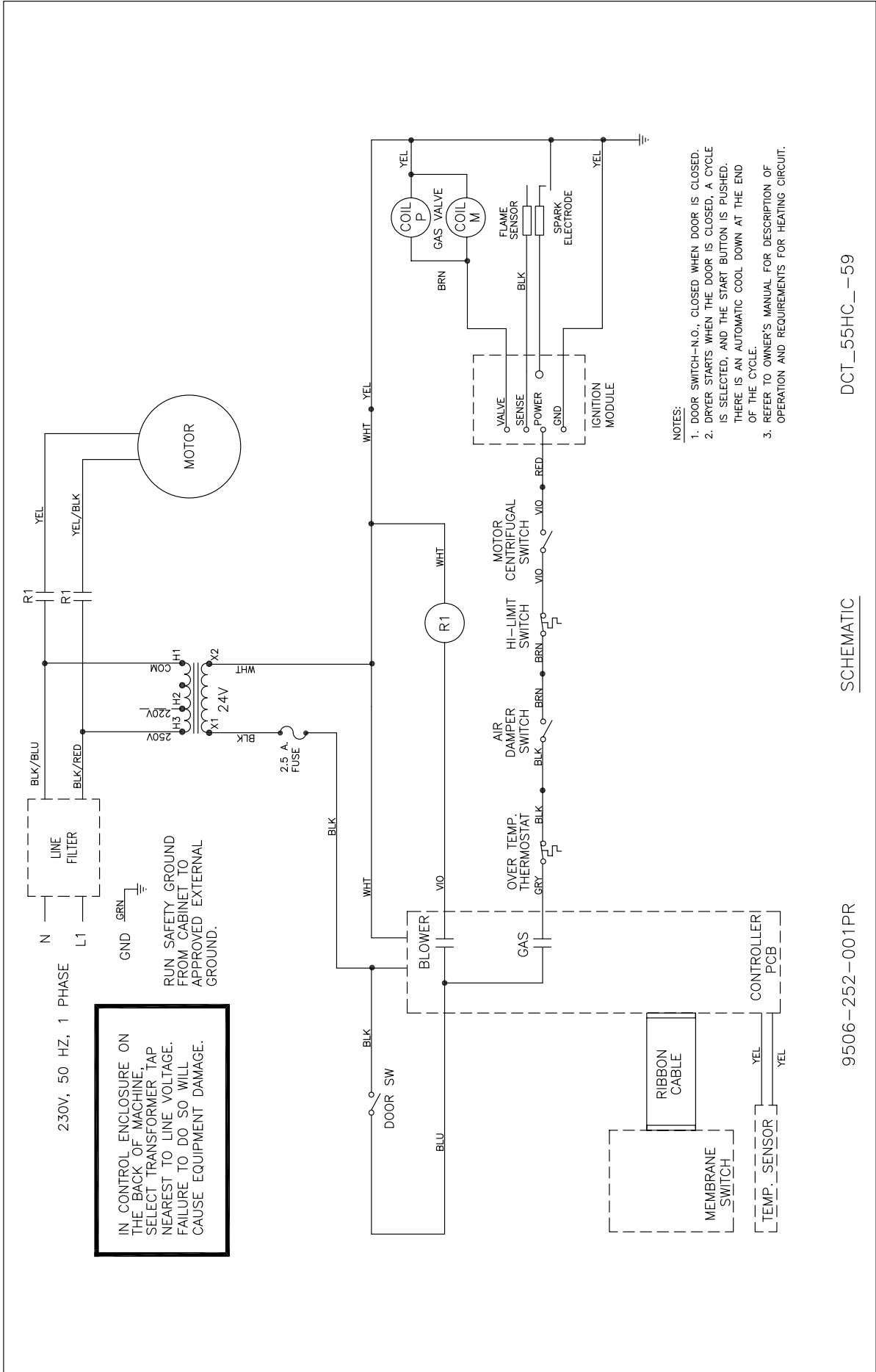

- NOTES:
1. DOOR SWITCH-N.O., CLOSED WHEN DOOR IS CLOSED.
  2. DRYER STARTS WHEN THE DOOR IS CLOSED, A CYCLE IS SELECTED, AND THE START BUTTON IS PUSHED. THERE IS AN AUTOMATIC COOL DOWN AT THE END OF THE CYCLE.
  3. REFER TO OWNER'S MANUAL FOR DESCRIPTION OF OPERATION AND REQUIREMENTS FOR HEATING CIRCUIT.

DCT\_55HC\_-59

SCHEMATIC

9506-252-001PR

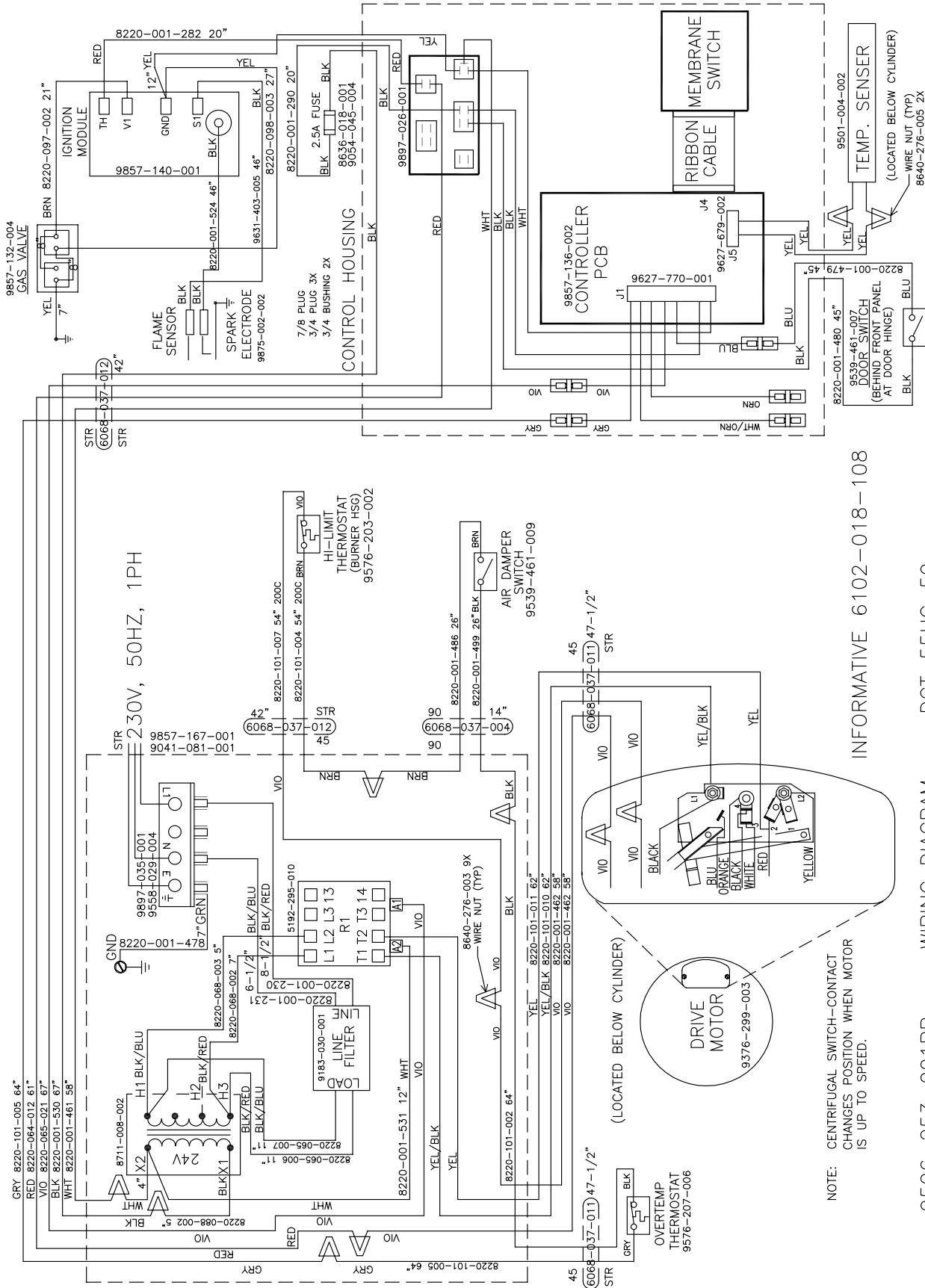

INFORMATIVE 6102-018-108

DCT\_55HC\_59

WIRING DIAGRAM

9506-253-001PR

---

# **Section 9:** **Maintenance**

---

## Daily

1. Clean lint screen by unlocking and sliding out in their tracks for access. Use soft brush if necessary. Failure to do so will slow drying and increase gas usage and temperatures throughout the dryer.
2. Check lint screen for tears. Replace if necessary.

## Monthly

1. Remove lint accumulation from end bells of motor.
2. Clean lint from lint screen compartment.
3. Remove lint and dirt accumulation from top of the dryer and all area above, and around the burners and burner housing. Failure to keep this portion of the dryer clean can lead to a build-up of lint creating a fire hazard.
4. Place a few drops of light oil on top and bottom pivots of the clothes door hinge.
5. Grease bearings and shaft of intermediate drive pulley.

## Quarterly

1. Check belts for looseness, wear or fraying.
2. Inspect gasket of door glass for excessive wear.
3. Check tightness of all fasteners holding parts to support channel.
4. Check tightness of tumbler shaft retaining nut.
5. Remove lint accumulation from primary air ports in burners.
6. Grease pivot pins and tension arms where in contact with each other.

## Semi-Annually

1. Remove and clean main burners.
2. Remove all orifices and examine for dirt and hole obstruction.
3. Remove all lint accumulation. Remove front panel, lint screen housing and remove lint accumulation.

## Annually

1. Check intermediate pulley bearings for wear.
2. Check and remove any lint accumulation from exhaust system.