



# **ES-3535**

# **Parts Manual**

## **Phase 8**

---

**American Dryer Corporation**  
88 Currant Road  
Fall River MA 02720-4781 USA  
Telephone: +1 (508) 678-9000 / Fax: +1 (508) 678-9447  
e-mail: [techsupport@amdry.com](mailto:techsupport@amdry.com)

[www.amdry.com](http://www.amdry.com)

# Retain This Manual In A Safe Place For Future Reference

American Dryer Corporation products embody advanced concepts in engineering, design, and safety. If this product is properly maintained, it will provide many years of safe, efficient, and trouble free operation.

**ONLY qualified technicians should service this equipment.**

**OBSERVE ALL SAFETY PRECAUTIONS** displayed on the equipment or specified in the installation manual included with the dryer.

The following “**FOR YOUR SAFETY**” caution must be posted near the dryer in a prominent location.

## FOR YOUR SAFETY

Do not store or use gasoline or other flammable vapors and liquids in the vicinity of this or any other appliance.

## POUR VOTRE SÉCURITÉ

Ne pas entreposer ni utiliser d'essence ni d'autres vapeurs ou liquides inflammables à proximité de cet appareil ou de tout autre appareil.

We have tried to make this manual as complete as possible and hope you will find it useful. ADC reserves the right to make changes from time to time, without notice or obligation, in prices, specifications, colors, and material, and to change or discontinue models.

## Important

For your convenience, log the following information:

DATE OF PURCHASE \_\_\_\_\_ MODEL NO. **ES-3535**  
RESELLER'S NAME \_\_\_\_\_  
Serial Number(s) \_\_\_\_\_  
\_\_\_\_\_  
\_\_\_\_\_

Replacement parts can be obtained from your reseller or the ADC factory. When ordering replacement parts from the factory, you can FAX your order to ADC at (508) 678-9447 or telephone your order directly to the ADC Parts Department at (508) 678-9000. Please specify the dryer model number and serial number in addition to the description and part number, so that your order is processed accurately and promptly.

The illustrations on the following pages may not depict your particular dryer exactly. The illustrations are a composite of the various dryer models. Be sure to check the descriptions of the parts thoroughly before ordering.

### **“IMPORTANT NOTE TO PURCHASER”**

Information must be obtained from your local gas supplier on the instructions to be followed if the user smells gas. These instructions must be posted in a prominent location near the dryer.

# Table of Contents

Overview Breakdown .....	4
Front Panel / Door Assembly .....	5
Trim / Control Panels .....	6
Blower Assembly .....	7
Rear Panel Assembly .....	8
Gas Train Assembly .....	9
Wheel Assembly .....	10
Motor Assembly .....	11
S.A.F.E. System Assembly .....	12

# Overview Breakdown

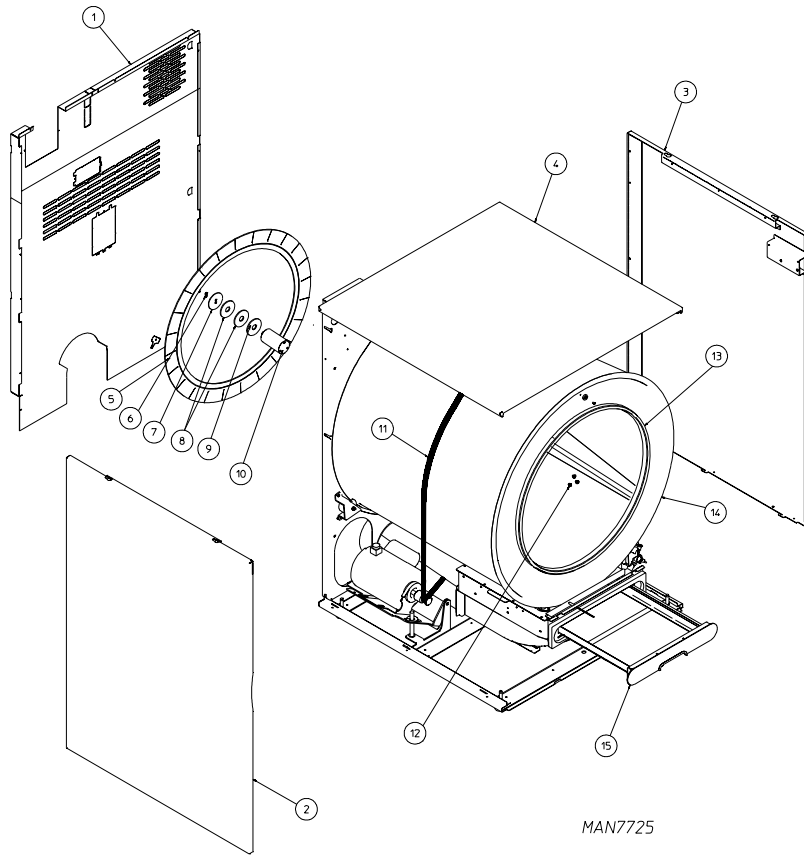

MAN7725

<u>Illus. No.</u>	<u>Part No.</u>	<u>Qty.</u>	<u>Description</u>
1	320724	1	Upper Back Guard (for models mfd. as of February 13, 2012)
	307092	1	Upper Back Guard (for models mfd. prior to February 13, 2012)
	320716	1	Lower Back Guard (for models mfd. as of February 13, 2012)
	307091	1	Lower Back Guard (for models mfd. prior to February 13, 2012)
	816238	1	Exhaust Transition (for models mfd. as of February 13, 2012)
	801372	1	Exhaust Transition (for models mfd. prior to February 13, 2012)
	2	801348	1
3	801346	1	Right Side Assembly
4	801349	1	Outer Top
5	115910	1	Rear Tumbler Felt
6	153064	2	1/4-20 x 1/2" Socket Head Cap Screw
7	185426	1	Backup Washer Two Screw
8	153048	2	Friction Pad
9	354217	1	Spacer Plate
10	185240	1	Tumbler Shaft
11	102407	1	Autotension Belt
12	150123	3	1/4-20 x 1/4" Allen Bolt
13	115906	1	Front Tumbler Felt
14	815175	1	Galvanized Tumbler Assembly
	815176	1	Stainless Steel Tumbler Assembly
15	801143	1	Lint Screen Assembly (Black)
	801144	1	Lint Screen Assembly (White)

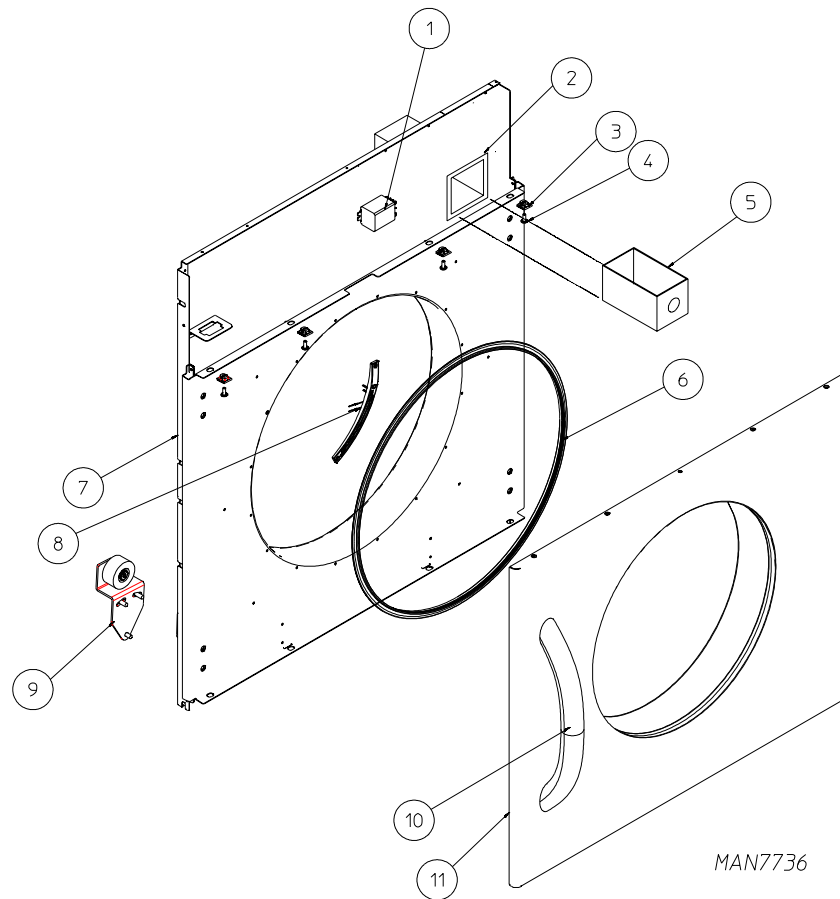

<u>Illus. No.</u>	<u>Part No.</u>	<u>Qty.</u>	<u>Description</u>
1	131819	1	120V 25a Reversing Relay
	131818	1	240V 25a Reversing Relay
2	819227	1	Coin Vault Assembly
3	154059	4	U-Style Clip on Nut (for models mfd. as of November 24, 2009)
	154061	4	Tinnerman U-Nut Retainer (for models mfd. prior to November 24, 2009)
4	154364	4	#10-16 x 1/2" Phillips Stainless Steel Screw (for models mfd. as of November 24, 2009)
	183129	4	#10-32 x 1/2" T20 (for models mfd. prior to November 24, 2009)
5	125916	1	Coin Box
6	102396	1	Door Gasket
7	829080	1	Front Panel Assembly without Auto Cycle
	828165	1	Front Support Panel Assembly with Auto Cycle
8	819805	1	Moisture Control Sensor
9	818183	1	Front Right Wheel Assembly <b>(refer to Wheel Assembly on page 10)</b>
	818184	1	Front Left Wheel Assembly <b>(refer to Wheel Assembly on page 10)</b>
10	819838	1	White Door Handle
	887175	1	Silver Door Handle
11	816197	1	Door Assembly Hinge Right Cold Rolled Steel (painted) Models mfd. with 20-1/2" Glass
	814641	1	Door Assembly Hinge Right Stainless Steel Models mfd. with 20-1/2" Glass
	819301	1	Door Assembly Hinge Right Cold Rolled Steel (painted) Models mfd. with 18" Glass
	816181	1	Door Assembly Hinge Right Stainless Steel Models mfd. with 18" Glass

# Trim / Control Panels

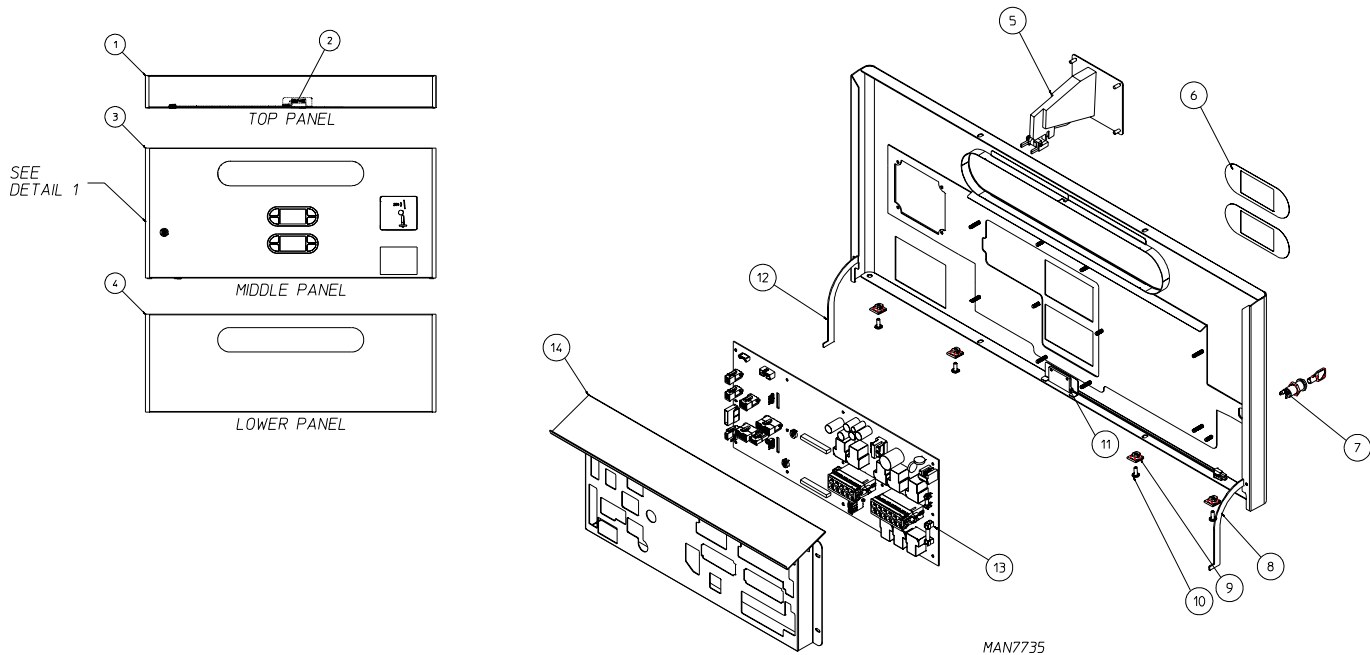

MAN7735

Illus. No.	Part No.	Qty.	Description
1	819205	1	Top Trim Panel Assembly (White)
	819191	1	Top Trim Panel Assembly (Stainless Steel)
2	819196	1	Door Switch Assembly
3	814684*	1	Phase 8 Control Door
	814688*	1	Phase 8 Control Door Assembly (25¢ Coin) (includes illus. nos. 3 and 5 through 14)
	814691*	1	Phase 8 Control Door Assembly (Programmable – Euro) (includes illus. nos. 3 and 5 through 14)
	801591*	1	Phase 8 Control Door Assembly (Non-Coin) (includes illus. nos. 3, 6, 11 through 13, and 15 through 14)
4	185097	1	Toe Panel (White)
	185048	1	Toe Panel (Stainless Steel)
5	818213	1	Coin Acceptor Assembly (25¢ Coin)
	819807	1	Optic Switch Assembly
	819264	1	Coin Acceptor (Programmable – Euro)
6	112587	2	Keypad (Coin)
	112586	2	Keypad (Non-Coin)
7	160071	1	Lock
8	318929	1	Control Panel Left Hinge
9	154061	8	U-Nut Retainer
10	183129	8	T-20 Truss Head Machine Screw
11	819196	1	Door Switch Assembly
12	318930	1	Control Panel Right Hinge
13	887102	1	Phase 8 Computer
	887103	1	Phase 8 Computer with “S.A.F.E.” System Option
	136116	1	3-amp “Glass” Fuse
	136054	2	15-amp “Ceramic” Fuse
14	319009	1	Phase 8 Control Cover

\* Specify color when ordering.

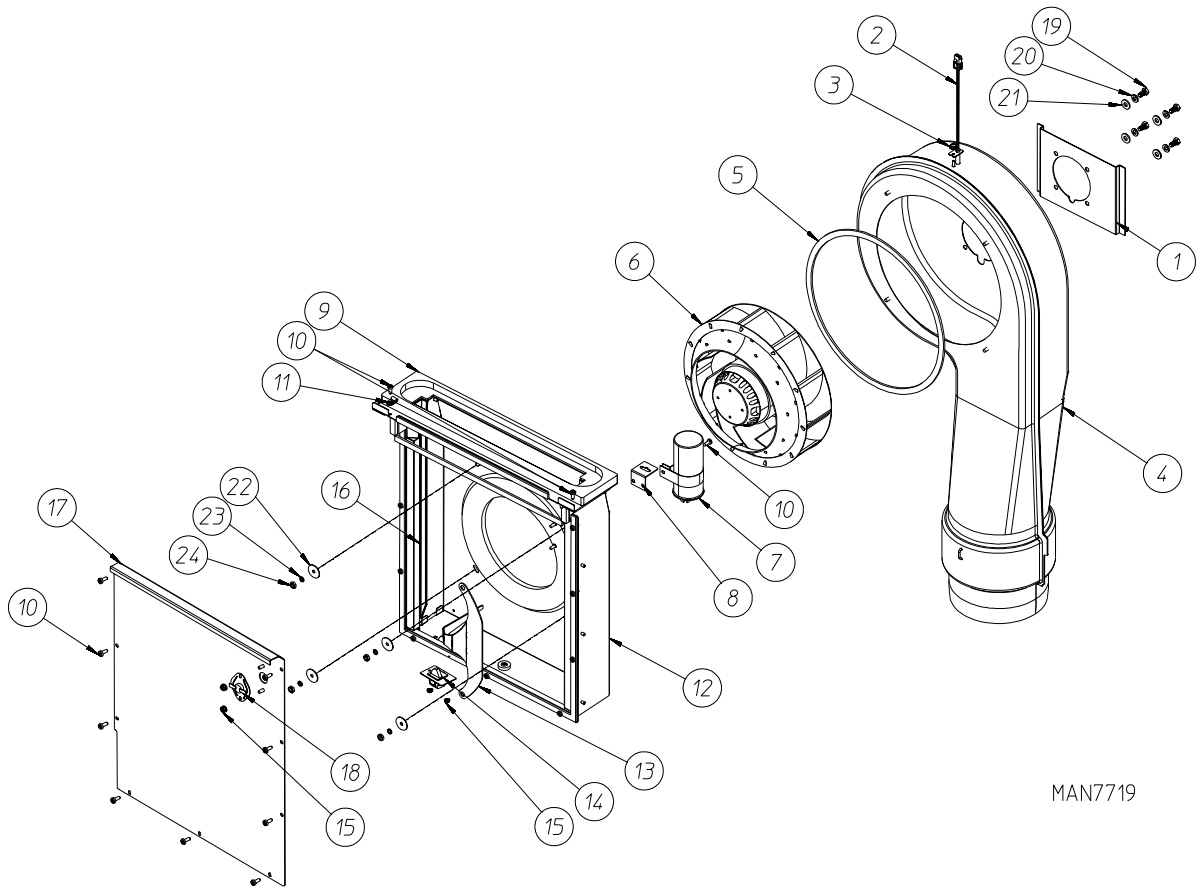

MAN7719

<u>Illus. No.</u>	<u>Part No.</u>	<u>Qty.</u>	<u>Description</u>
1	185340	1	Blower Housing Mount
2	830333	1	Phase 8 Exhaust Sensor
3	151000	1	#6-32 Pal Nut
4	185084	1	Blower Housing Assembly
5	117604	2	1/8" Thk x 3/8" W Sponge Gasket
6	887191	1	115V Motorized Impellor
7	100683	1	20mfd 440V Capacitor
8	185431	1	Lint Box Wire Support
9	102368	1	Lint Gasket
10	150331	12	#8-18 x 1/2" T20 TORX®
11	121519	1	Cable Clamp 3/8" x 0.05 x 0.125 ID
12	801375	1	120V Lint Box Housing
13	333717	1	Lint Blades Straight
14	122002	1	Spst Door Switch, 5a 250 VAC
15	153073	4	#8-32 Keps Nut Steel
16	185215	1	Right Lint Rail
	185216	1	Left Lint Rail
17	819419	1	Lint Box Top Assembly
18	130119	1	L190 Temp Sensor
19	150691	4	Bolt 6 x 12mm
20	153007	4	1/4" Split Lock Washer
21	153018	4	1/4" Flat Washer
22	153049	4	0.203 ID x 0.875 OD x 0.040 Washer
23	153024	4	#10 Split Lock Washer
24	152008	4	#10-32 Hex Nut

# Rear Panel Assembly

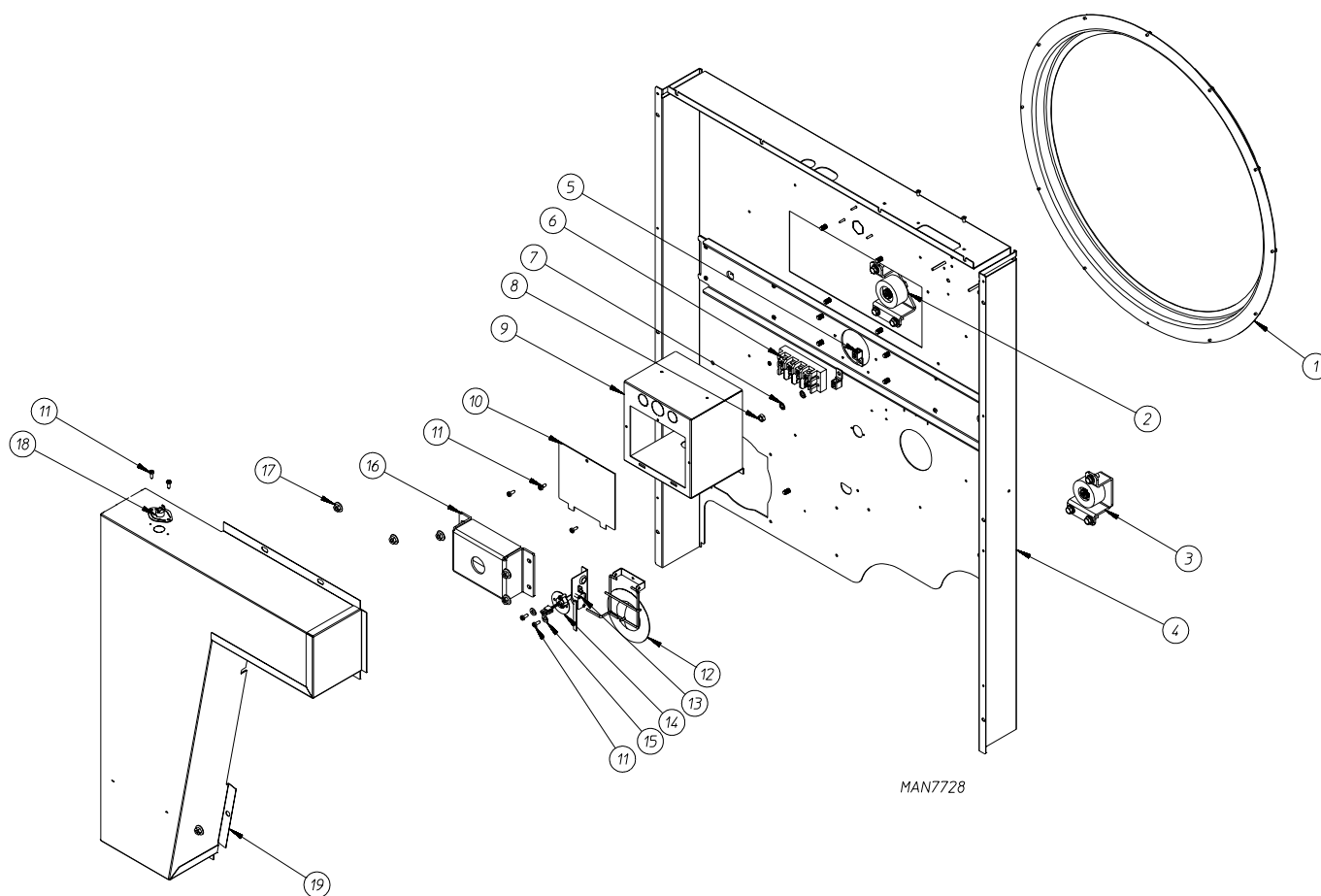

<u>Illus. No.</u>	<u>Part No.</u>	<u>Qty.</u>	<u>Description</u>
1	185650	1	Rear Bulkhead
2	818110	1	Rear Left Roller Wheel
3	818109	1	Rear Right Roller Wheel Assembly
4	801369	1	Rear Support Panel Stud Assembly
5	121010	2	14-4 Terminal Lug
6	120728	1	Quick-Conn Term Block 4 Pole
7	153021	2	1/4" Ext/Int Shakeproof Washer
8	152002	1	1/4-20 Hex Nut
9	307088	1	Rear Electrical Box
10	185467	1	Electrical Cover
11	150331	7	#8-18 x 1/2" T20 TORX®
12	828238	1	Linkageless Sail Switch Assembly (for models mfd. as of December 2, 2011)
	802817	1	Sail Switch with Rod and Dome Damper (for models mfd. prior to December 2, 2011)
13	802807	1	Switch Bracket Assembly (for models mfd. prior to December 2, 2011)
	122200	1	Sail Switch (for models mfd. prior to December 2, 2011)
14	819188	1	F.S.S. Temp Sensor
15	153022	2	#10 Flat Washer
16	315434	1	Thrust Bearing Box
17	152014	6	1/4-20 Serrated Hex Flange Nut
18	183112	1	High-Limit Thermo
19	815128	1	Heat Duct



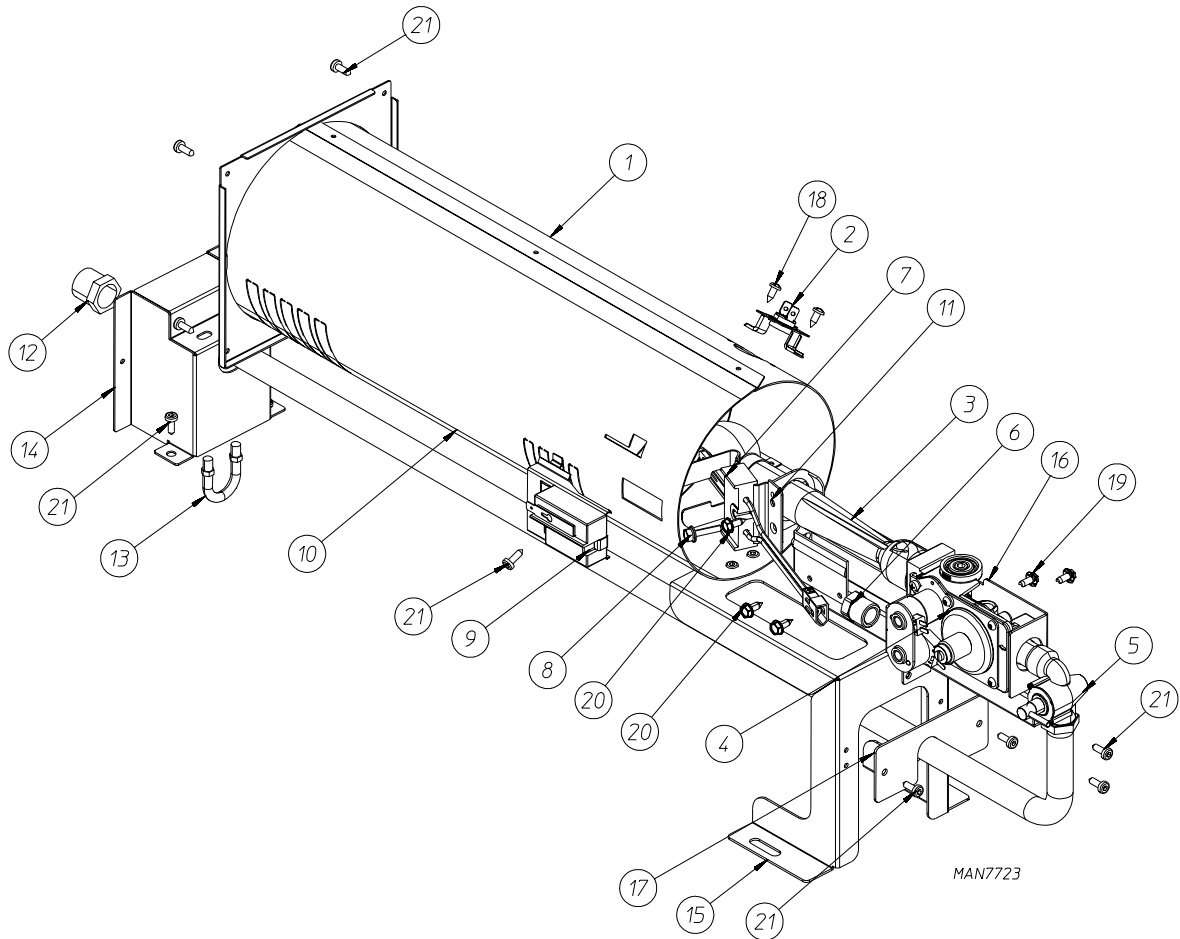

Illus. No.	Part No.	Qty.	Description
1	819164	1	Burner Tube
2	183112	1	Thermostat, Gas High-Limit
3	183144	1	Inshot Burner Tube, Hot Surface Ignition
4	128981	1	Hi Capacity Gas Valve
5	141318	1	3/8" 90° Union Shutoff
6	140888	1	Natural Gas Burner Orifice #23
	140876	1	Liquid Propane Gas Burner Orifice #42
	884355	1	ES35/35 Liquid Propane Conversion Kit
7	128910	1	Globar®
8	183145	1	#8-32 x 7/8" Hex Screw with Washer
9	130500	1	Radiant Control
10	141262	1	3/8" N.P.T. Male 90° Gas Pipe
	142953	1	1/2" x 3/8" Reducer
11	185063	1	Igniter Bracket
12	142953	1	Steel Bushing 3/8" x 1/2"
13	154356	1	U-Bolt for 3/8" Pipe
14	185434	1	Gas Pipe Bracket
15	319332	1	Gas Train Support
16	307090	1	Gas Valve Bracket
17	307093	1	Gas Pipe Stabilizer
18	150301	2	Phillips Pan Head Screw
19	152209	2	Plated Tapping Screw
20	152208	3	Sheet Metal Screw
21	150331	13	T-20 Pan Head Screw

# Wheel Assembly

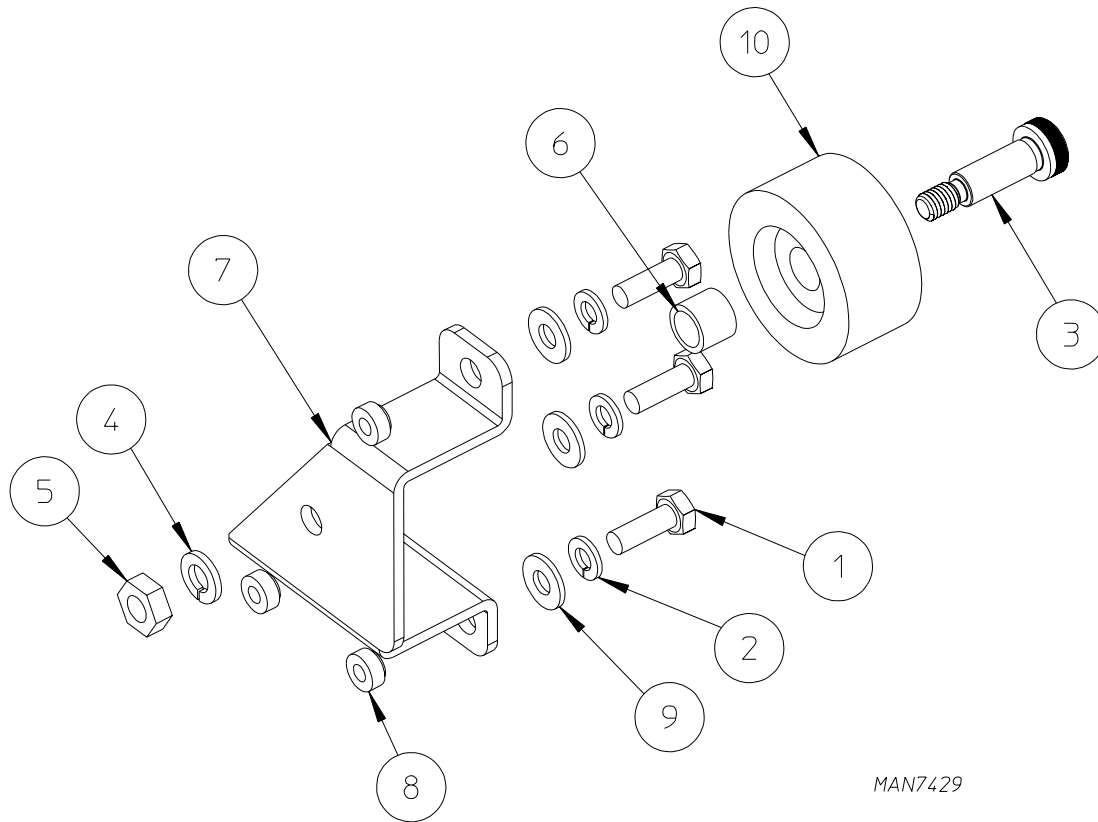

MAN7429

<u>Illus. No.</u>	<u>Part No.</u>	<u>Qty.</u>	<u>Description</u>
1	150510	3	1/4-20 x 3/4" Hex Head Machine Bolt
2	153007	3	1/4" Lock Washer
3	154267	1	M10 x 25mm Shoulder Screw
4	153002	1	5/16" Lock Washer
5	154013	1	M8 Hex Nut
6	154284	1	Tumbler Wheel Spacer
7	318233	1	Rear Right Roller Wheel Bracket
	318232	1	Rear Left Roller Wheel Bracket ... Not Illustrated
	318532	1	Front Right Wheel Bracket ... Not Illustrated
	318531	1	Front Left Wheel Bracket ... Not Illustrated
8	153564	3	1/4-20" Clinch Nut
9	153018	3	1/4" Flat Washer
10	180050	1	Wheel

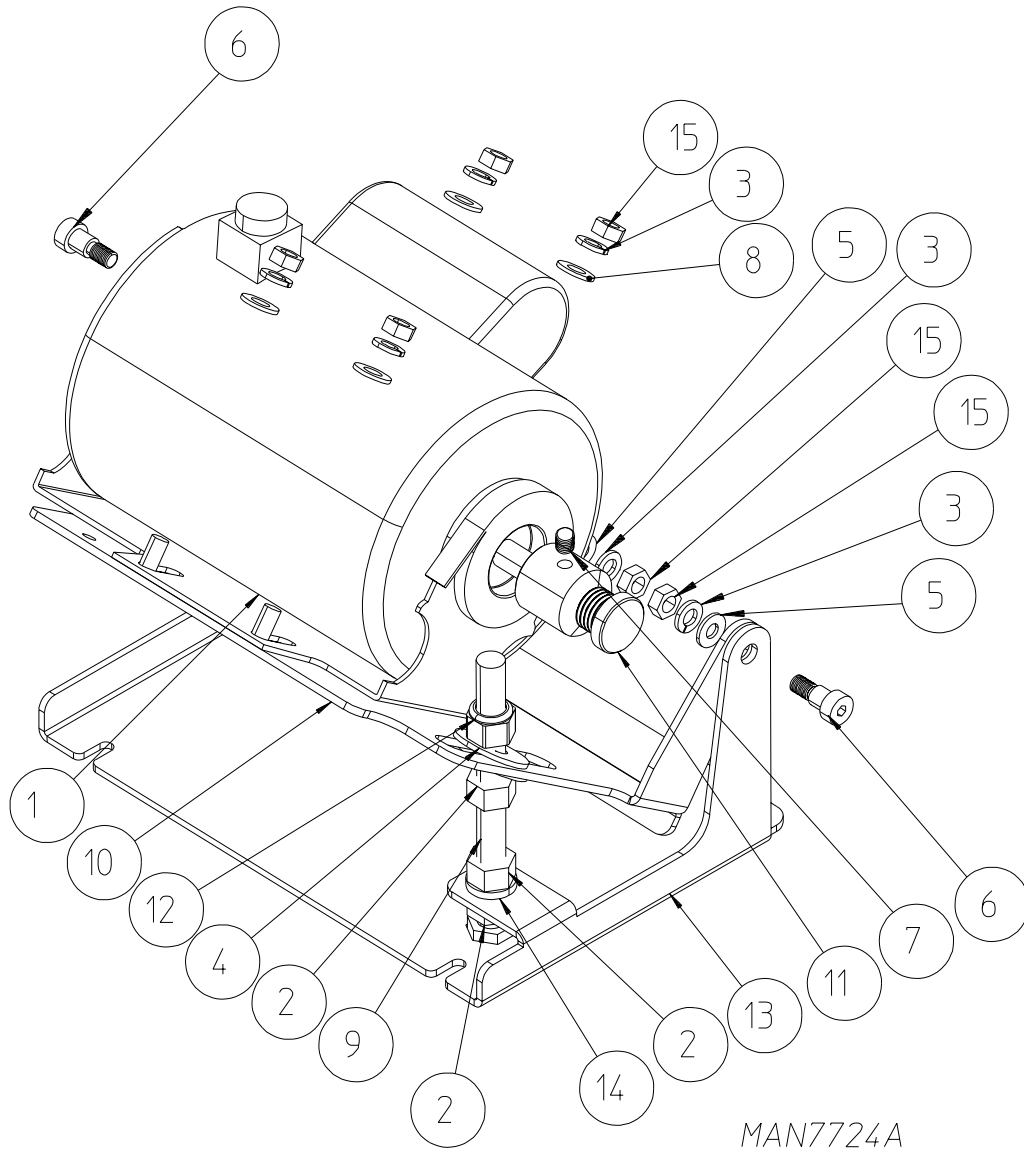

MAN7724A

<u>Illus. No.</u>	<u>Part No.</u>	<u>Qty.</u>	<u>Description</u>
1	887196	1	Motor 3 Rib Tumbler with Sheave 60 Hz
2	152011	3	1/2-13 Hex Nut
3	153002	6	5/16" Lock Washer
4	153011	2	9/16" ID Flat Washer
5	153018	2	1/4" Flat Washer
6	154266	2	3/8" x 3/8" (Shoulder Screw)
7	154321	1	5/16-24 x 3/8" Alan Setscrew
8	153001	4	5/16" Flat Washer
9	150616	1	1/2-13 x 5-1/2" Tap Bolt
10	819710	1	Motor Mount Stud Assembly
11	319933	1	45 RPM Tumbler Sheave
12	152028	1	1/2-13 Nylon Insert Locknut
13	319266	1	Motor Mount Base Plate
14	153026	1	1/2" Std Lock Washer
15	152004	6	5/16-18 Hex Nut

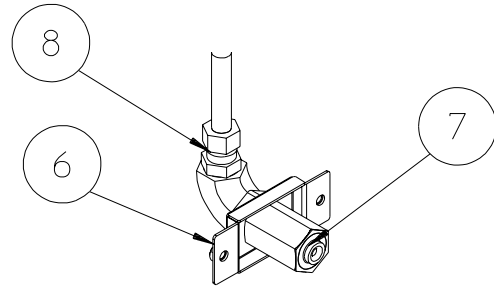
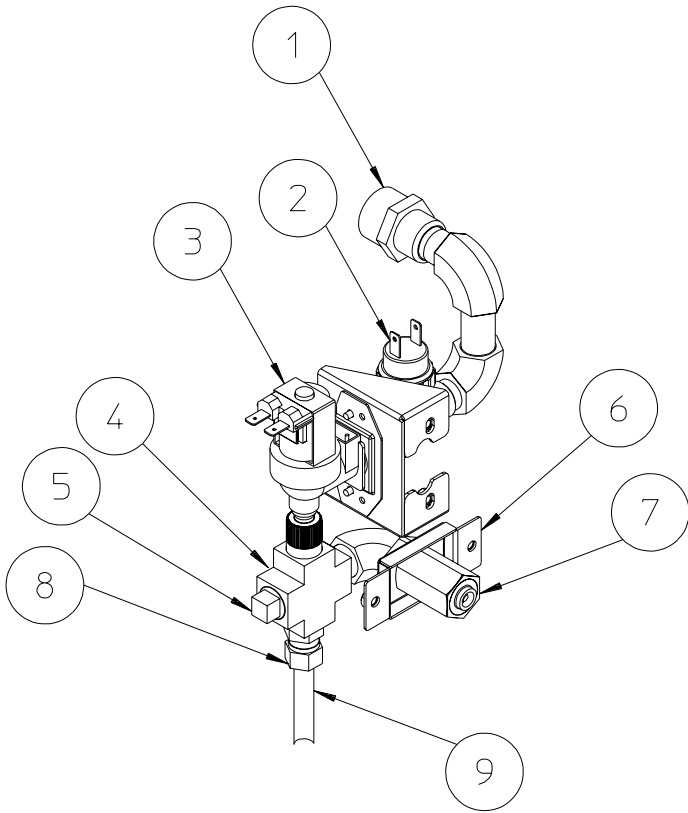

MAN7425

<u>Illus. No.</u>	<u>Part No.</u>	<u>Qty.</u>	<u>Description</u>
1	143025	1	Nylon Hose Adaptor
2	136987	1	Pressure Switch
3	165120	1	Water Valve
4	143236	1	3/8" Brass Cross
5	143251	1	3/8" Plug
6	318422	1	Sensor Activated Fire Extinguishing System Bracket
7	143581	1	Spray Nozzle
8	143208	1	3/8" Brass Connector
9	143099	1	3/8" OD Copper Tubing



