



HB76 / ES76 Parts Manual

American Dryer Corporation
88 Currant Road
Fall River, MA 02720-4781
Telephone: (508) 678-9000 / Fax: (508) 678-9447
E-mail: techsupport@amdry.com

www.amdry.com

Retain This Manual In A Safe Place For Future Reference

American Dryer Corporation products embody advanced concepts in engineering, design, and safety. If this product is properly maintained, it will provide many years of safe, efficient, and trouble free operation.

ONLY qualified technicians should service this equipment.

OBSERVE ALL SAFETY PRECAUTIONS displayed on the equipment or specified in the installation manual included with the dryer.

The following “**FOR YOUR SAFETY**” caution must be posted near the dryer in a prominent location.

FOR YOUR SAFETY

Do not store or use gasoline or other flammable vapors and liquids in the vicinity of this or any other appliance.

POUR VOTRE SÉCURITÉ

Ne pas entreposer ni utiliser d'essence ni d'autres vapeurs ou liquides inflammables à proximité de cet appareil ou de tout autre appareil.

We have tried to make this manual as complete as possible and hope you will find it useful. ADC reserves the right to make changes from time to time, without notice or obligation, in prices, specifications, colors, and material, and to change or discontinue models.

Important

For your convenience, log the following information:

DATE OF PURCHASE _____ MODEL NO. _____

RESELLER'S NAME _____

Serial Number(s) _____

Replacement parts can be obtained from your reseller or the ADC factory. When ordering replacement parts from the factory, you can FAX your order to ADC at (508) 678-9447 or telephone your order directly to the ADC Parts Department at (508) 678-9000. Please specify the dryer model number and serial number in addition to the description and part number, so that your order is processed accurately and promptly.

The illustrations on the following pages may not depict your particular dryer exactly. The illustrations are a composite of the various dryer models. Be sure to check the descriptions of the parts thoroughly before ordering.

“IMPORTANT NOTE TO PURCHASER”

Information must be obtained from your local gas supplier on the instructions to be followed if the user smells gas. These instructions must be posted in a prominent location near the dryer.

Table of Contents

Cabinet Diagram	4
Control Panel / Lower Panel	6
Rear Dryer Panel	8
Lint Box / Lint Screen for models mfd. as of October 14, 2009	10
Lint Box / Lint Screen for models mfd. prior to October 14, 2009	12
Blower Motor Assembly	13
60 Hz Gas Burner Assembly	14
50 Hz Gas Burner Assembly	16
Steam Coil / Electric Oven Assembly	18
Drive Motor Assembly	19
Sail Switch Assembly	20
Motor Contactor Panel	21
Fire Suppression System	22
Tumbler Wheel Assembly	23
Transformer Assembly	24

Cabinet Diagram

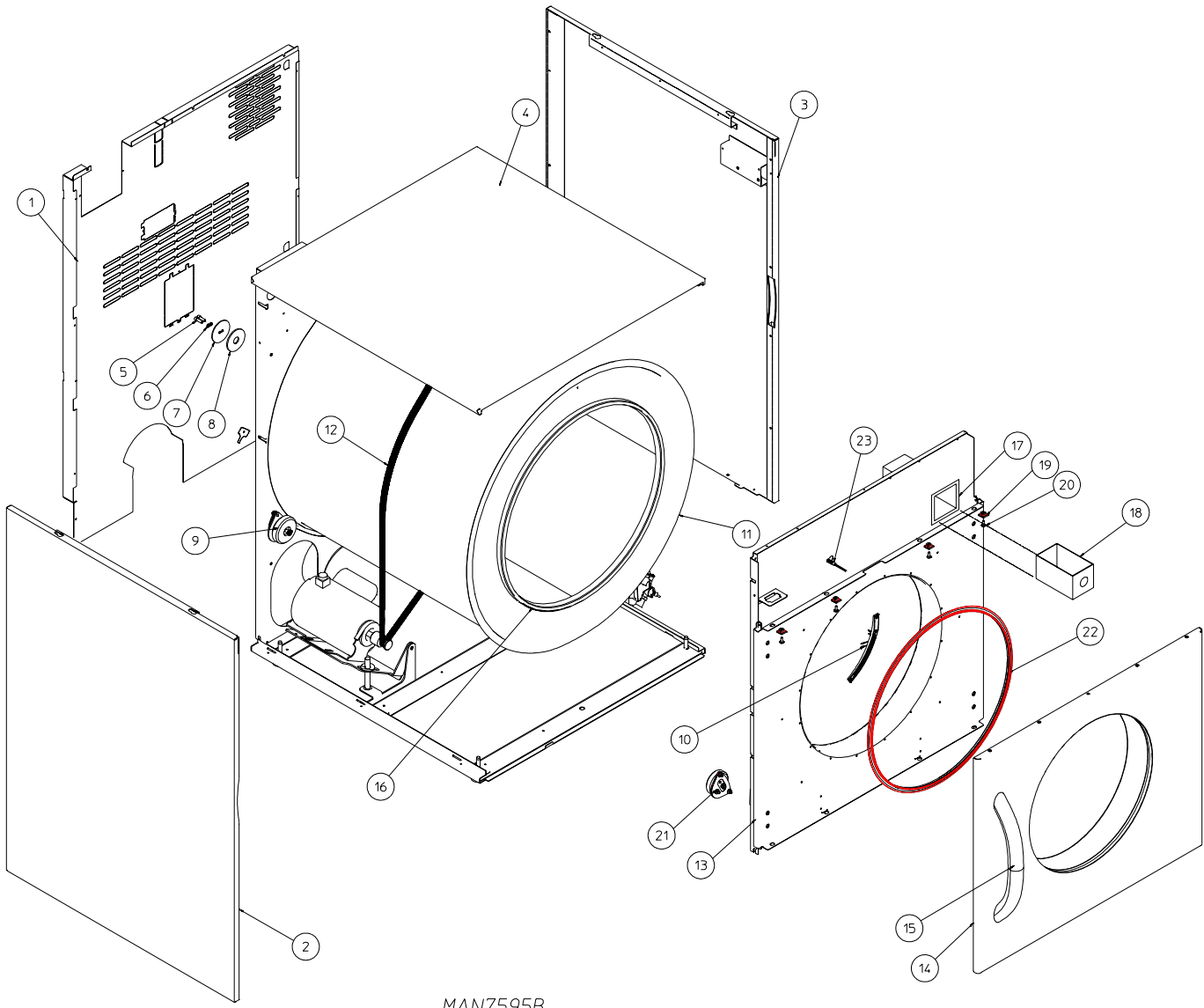

<u>Illus. No.</u>	<u>Part No.</u>	<u>Qty.</u>	<u>Description</u>
1	814653	1	2-Piece Back Guard Assembly (gas and electric) (for models mfd. as of November 18, 2010)
	814654	1	2-Piece Back Guard Assembly (steam) (for models mfd. as of November 18, 2010)
	822363	1	2-Piece Back Guard Assembly (gas and electric) (for models mfd. prior to November 18, 2010)
	822096	1	2-Piece Back Guard Assembly (steam) (for models mfd. prior to November 18, 2010)
	320674	1	Top Back Guard (gas and electric)
	323038	1	Top Back Guard (steam)
	333831	1	Bottom Back Guard (for models mfd. as of November 18, 2010)
	323372	1	Bottom Back Guard (for models mfd. prior to November 18, 2010)
	2	851549	1
3	851548	1	Tall Right-Hand Side Panel Assembly
4	822362	1	Top Panel Assembly
5	153064	2	1/4-20 x 1/2" Socket Cap Screw
6	153072	2	1/4" High Collar Lock Washer
7	185426	1	Dual Screw Backup Washer
8	153048	2	Inner Friction Pad
	354217	1	3/4" Plate Spacer ... Not Illustrated
	185240	1	Extended Tumbler Shaft ... Not Illustrated
9	851530	2	Rear Wheel Bracket Assembly (refer to Tumbler Wheel Assembly on page 23)
10	819365	1	Moisture Sensor Assembly
11	851376	1	Galvanized Tumbler Assembly
	851555	1	Stainless Steel Tumbler Assembly
12	102415	1	15 Rib Drive Belt
13	887256	1	Non-Coin Front Support Panel with Auto (black)
	887257	1	Coin Front Support Panel (black)
14	851274*	1	Main Door Assembly with Handle (painted)
	851272	1	Main Door Assembly with Handle (stainless steel)
	103067	3	Door Hinge ... Not Illustrated
15	170233*	1	Main Door Handle
	150328	2	Door Handle Screw ... Not Illustrated
16	115911	1	Front Tumbler Felt
17	851384	1	Coin Vault
	819286	1	Coin Vault Jumper Harness
18	125916	1	Coin Box with 2 Keys (each lock keyed different)
19	154059	4	U-Nut Retainer (for models mfd. as of March 9, 2009)
	154061	4	U-Nut Retainer (for models mfd. prior to March 9, 2009)
20	154364	4	#10-16 x 1/2" Phillips Truss Head Screw (for models mfd. as of March 9, 2009)
	183129	4	#10-32 x 1/2" T20 Truss Head Screw (for models mfd. prior to March 9, 2009)
21	851529	2	Front Wheel Bracket Assembly (refer to Tumbler Wheel Assembly on page 23)
22	102397	1	Door Gasket
23	818370	1	Rotation Sensor

* Specify color when ordering.

Control Panel / Lower Panel

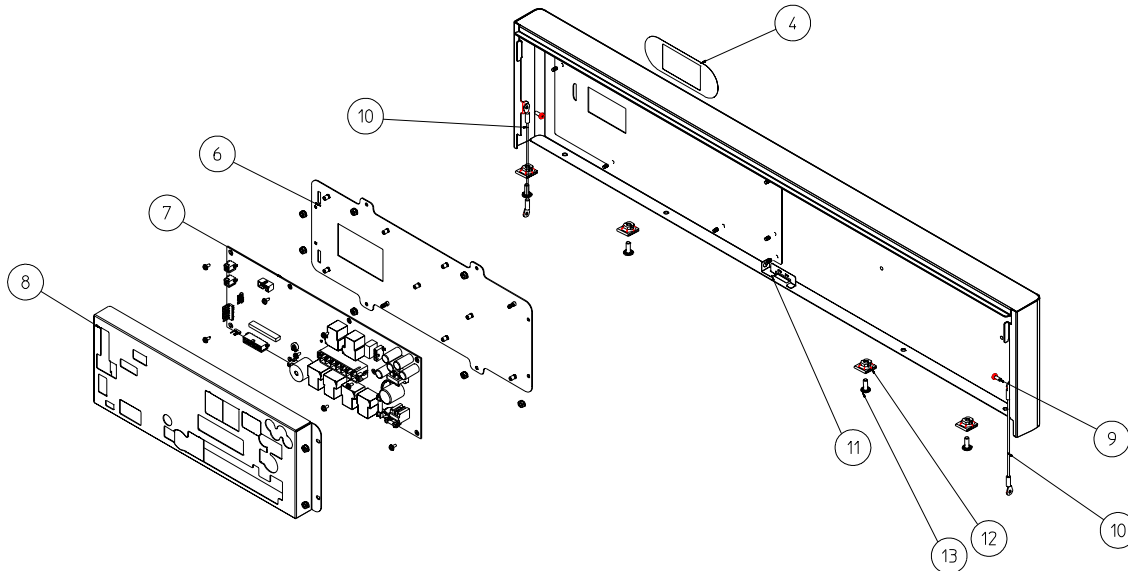
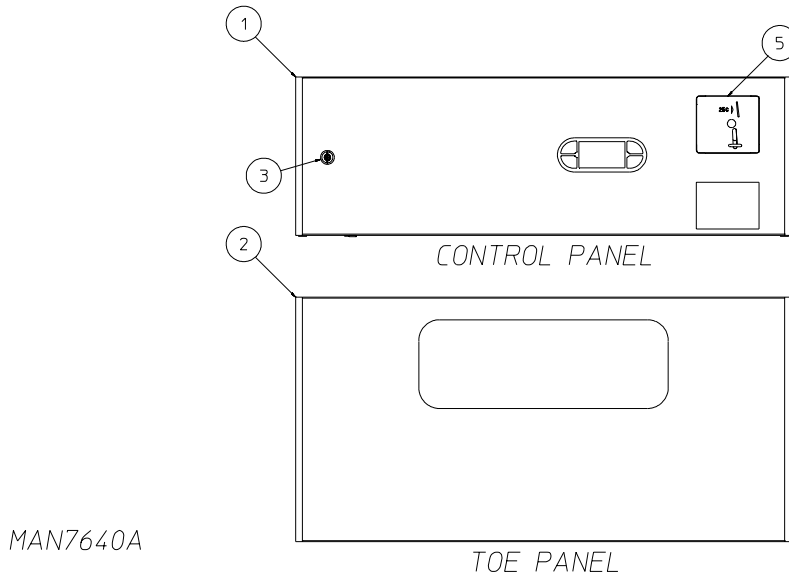

<u>Illus. No.</u>	<u>Part No.</u>	<u>Qty.</u>	<u>Description</u>
1	814605	1	Phase 8 Coin Control Panel Assembly Complete (for models mfd. as of August 10, 2010)
	851522	1	Phase 8 Coin Control Panel Assembly Complete (for models mfd. prior to August 10, 2010)
	814604	1	Phase 8 Non-Coin Control Panel Assembly Complete (for models mfd. as of August 10, 2010)
	851394	1	Phase 8 Non-Coin Control Panel Assembly Complete (for models mfd. prior to August 10, 2010)
	814603	1	Phase 8 Coin Control Panel (for models mfd. as of August 10, 2010)
	851521	1	Phase 8 Coin Control Panel (for models mfd. prior to August 10, 2010)
	814607	1	Phase 8 Non-Coin Control Panel (for models mfd. as of August 10, 2010)
	851385	1	Phase 8 Non-Coin Control Panel (for models mfd. prior to August 10, 2010)

<u>Illus. No.</u>	<u>Part No.</u>	<u>Qty.</u>	<u>Description</u>
2	814515*	1	Lower Panel (painted) (for models mfd. as of October 14, 2009)
	814584	1	Lower Panel (stainless steel) (for models mfd. as of October 14, 2009)
	825687*	1	Lower Panel (painted) (for models mfd. prior to October 14, 2009)
	825478	1	Lower Panel (stainless steel) (for models mfd. prior to October 14, 2009)
3	160071	1	Keylock Switch (for models mfd. as of August 10, 2010)
	160040	1	XX4451 Lock (for models mfd. prior to August 10, 2010)
	160140	2	XX4451 Key
	122200	1	Microswitch (for models mfd. prior to August 10, 2010)
	160066	1	Offset Cam for Lock (for models mfd. prior to August 10, 2010)
	154004	1	Twin Speed Nut (for models mfd. prior to August 10, 2010)
4	112587	1	Phase 8 Coin Keypad
	112586	1	Phase 8 Non-Coin Keypad
5	818213	1	25¢ Coin Acceptor Assembly with Optic Switch
	819264	1	Programmable Euro / UK Coin Acceptor
	887041	1	Optic Switch ONLY (for 25¢ coin acceptor)
6	819508	1	Control Mount Assembly
7	887092	1	Phase 8 Microprocessor without Fire Suppression System
	887093	1	Phase 8 Microprocessor with Fire Suppression System
	819541	1	Coin Block Jumper Harness (non-coin Only)
	136116	1	3-Amp Fuse
	136056	1	20-Amp Fuse
8	350250	1	Computer Board Cover
9	154220	2	Pop Rivet (for models mfd. as of August 10, 2010)
	150331	2	#8-18 x 1/2" TORX® Screw (for models mfd. prior to August 10, 2010)
10	333778	2	Panel Support Bracket (for models mfd. as of August 10, 2010)
	121350	2	Panel Support Cable (for coin models mfd. prior to August 10, 2010) ... Not Illustrated
	350303	2	Panel Support Bracket (for non-coin models mfd. prior to August 10, 2010) ... Not Illustrated
11	819196	1	Main Door Switch Assembly
	813411	1	Door Switch Extension Harness ... Not Illustrated
12	154059	4	U-Nut Retainer (for models mfd. as of March 9, 2009)
	154061	4	Tinnerman U-Nut Retainer (for models mfd. prior to March 9, 2009)
13	154364	4	#10-16 x 1/2" Phillips Truss Head Screw (for models mfd. as of March 9, 2009)
	183129	4	#10-32 x 1/2" T20 Truss Head (for models mfd. prior to March 9, 2009)

* Specify color when ordering.

Rear Dryer Panel

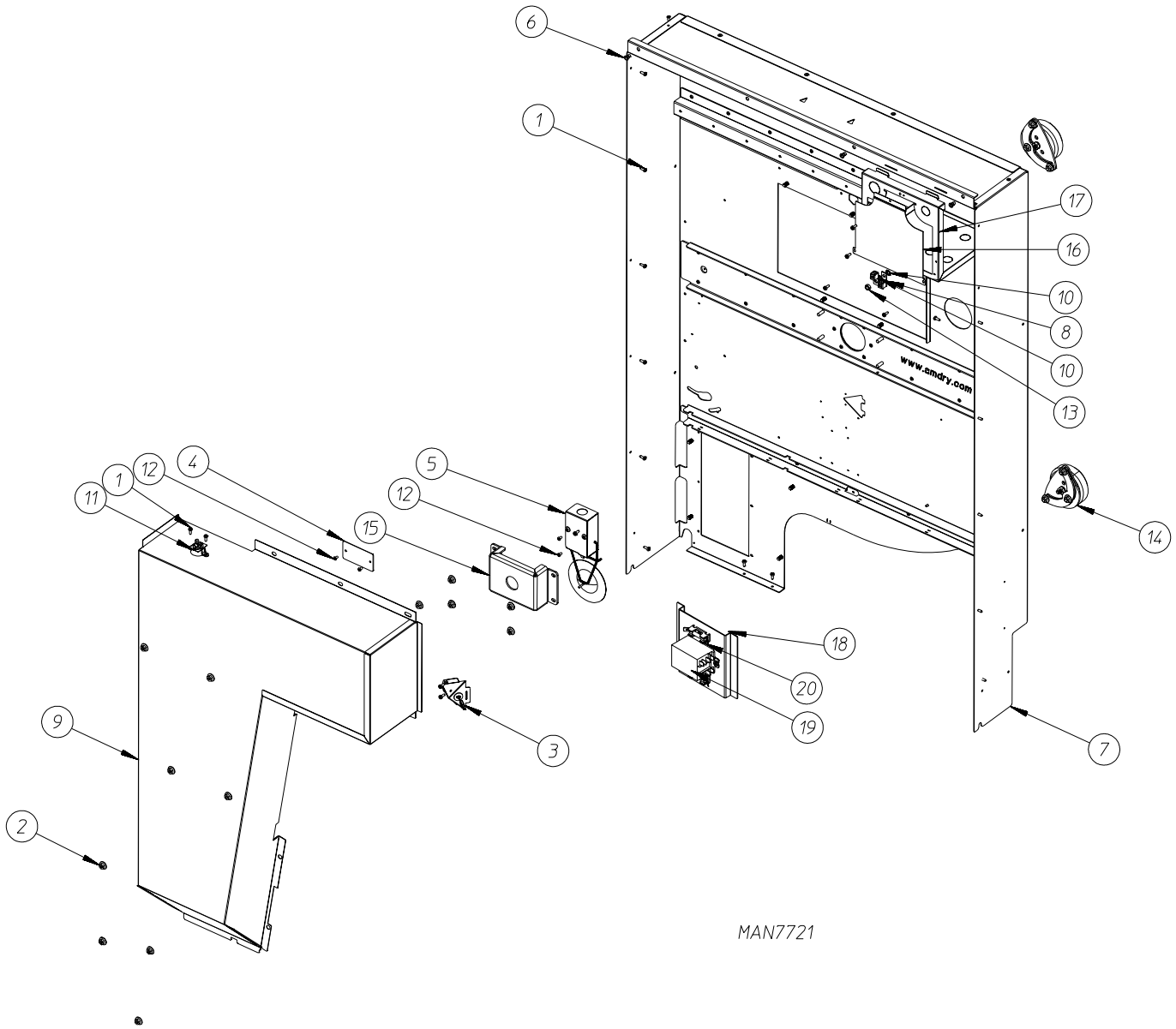

<u>Illus. No.</u>	<u>Part No.</u>	<u>Qty.</u>	<u>Description</u>
1	150331	22	#8-18 x 1/2" Pan Head TORX® Screw
2	152014	13	1/4-20 Serrated Hex Flange Nut
3	815207	1	Axial Probe Assembly
4	318691	1	Cover Plate for Models without S.A.F.E.
5	818570	1	Single Sail Switch Assembly (refer to Sail Switch Assembly on page 20)
6	152111	3	#10-32 Hex Body Rivnut
7	825961	1	Rear Tumbler Support Panel Complete (gas and electric) (includes illus. nos. 1 through 17)
	822114	1	Rear Tumbler Support Complete with Steam Coil (steam) (includes illus. nos. 1 through 4, 6 through 8, 10, 12 through 17)
8	121010	2	L70 14-4 Terminal Lug
9	851262	1	Heat Duct
	165067	1	Steam Coil ... Not Illustrated
10	153021	2	1/4" Star Washer
11	183112	1	205° Gas Hi-Limit Thermostat
12	154200	2	5/32" Pop Rivet
13	152002	1	1/4-20 Hex Nut
14	851530	2	Rear Wheel Bracket Assembly (refer to Tumbler Wheel Assembly on page 23)
15	350228	1	Thrust Bearing Box
16	350238	1	Electric Box Cover Plate
17	319653	1	Rear Electric Box
	120701	1	Gas and Steam Main Terminal Block ... Not Illustrated
	120699	1	Electric Main Terminal Block ... Not Illustrated
	120698	1	Electric Main Terminal Block Insulator ... Not Illustrated
18	801344	1	Split Phase Relay Assembly 208-240 Volt (includes illus. nos 18 through 20)
	319562	1	Split Phase Relay Bracket
19	136056	2	20-Amp Fuse
20	131818	1	25-Amp Relay 208-240 Volt

Lint Box / Lint Screen

For models mfd. as of October 14, 2009

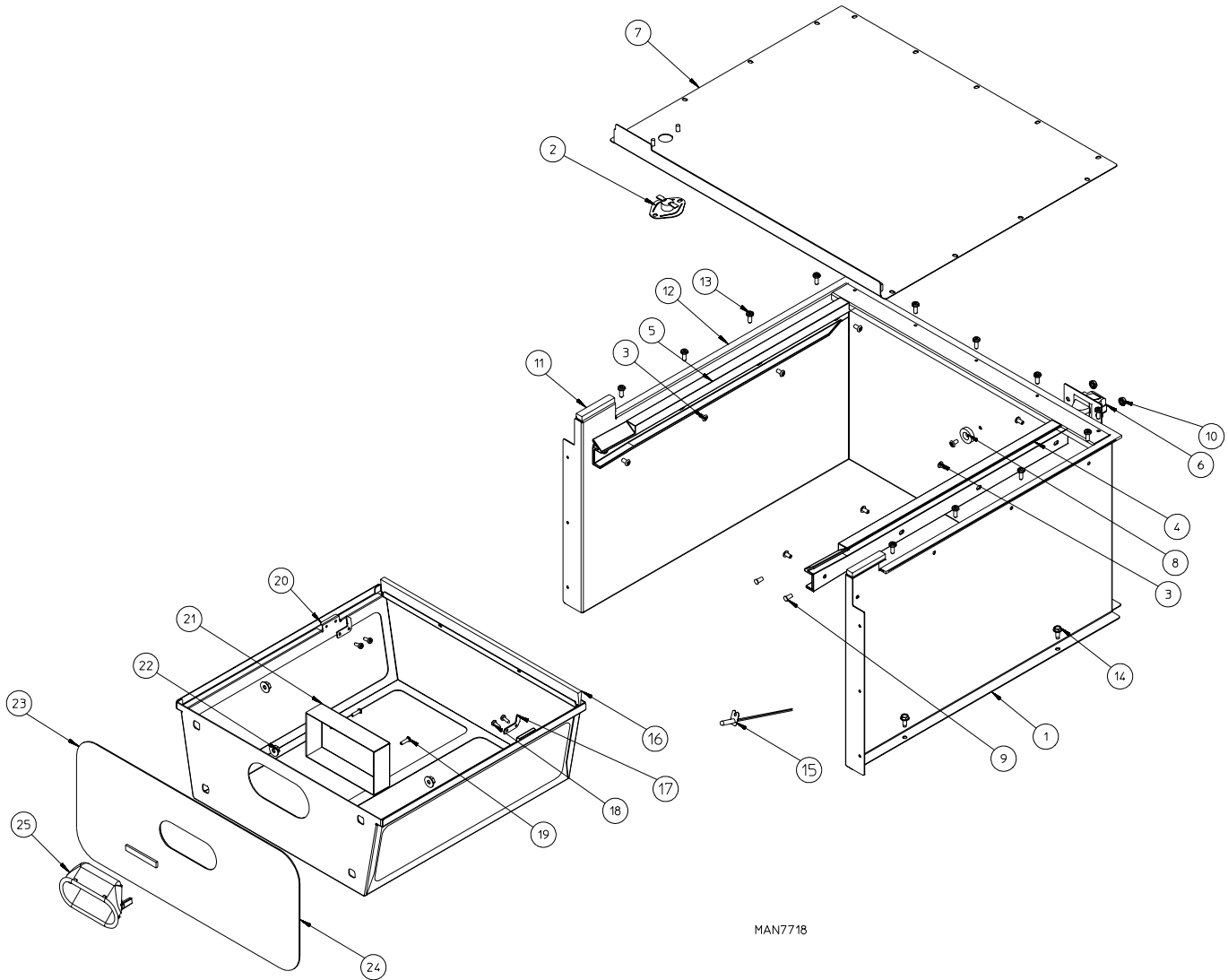

For models mfd. as of October 14, 2009

<u>Illus. No.</u>	<u>Part No.</u>	<u>Qty.</u>	<u>Description</u>
1	814513	1	Large Lint Box Assembly Complete (includes illus. nos. 1 through 15)
2	130119	1	190° Thermostat
3	154200	9	#5-32 Pop Rivet
4	185215	1	Lint Drawer Rail Right Side
5	185216	1	Lint Drawer Rail Left Side
6	819523	1	Lint Drawer Switch Assembly
	122002	1	Lint Drawer Switch ONLY
7	814514	1	Lint Box Top Assembly
8	102004	1	0.75 Round Magnet
9	153564	2	#8-32 x 0.375 Clinch Stud
10	153073	2	#8-32 Keps Nut
11	117607	2	1/4" x 3/8" Sponge Tape (sold by the foot)
12	117604	1	1/8" x 3/8" Sponge Tape (sold by the foot)
13	150331	13	#8-18 x 0.5 TORX® Screw
14	150300	7	#10-16 x 0.75 Hex Washer
15	836028	1	Exhaust Temperature Probe
	151000	1	Pal Nut ... Not Illustrated
16	170171	1	Lint Drawer Brush
17	185423	2	Lint Drawer Stop
18	150331	4	#8-18 x 0.5 TORX® Screw
19	150334	2	#8-16 x 19/32" Phillips Screw
20	814620*	1	Lint Drawer Assembly Complete (painted)
	814622	1	Lint Drawer Assembly Complete (stainless steel)
	814621	1	Lint Drawer (no handle)
21	333693	1	Handle Cup
22	152014	4	1/4-20 Hex Flange Nut
23	814510*	1	Lint Drawer Handle (painted)
	814580	1	Lint Drawer Handle (stainless steel)
24	117604	1	Neo Sponge Tape
25	185148	1	Lint Drawer Handle

* Specify color when ordering.

Lint Box / Lint Screen

For models mfd. prior to October 14, 2009

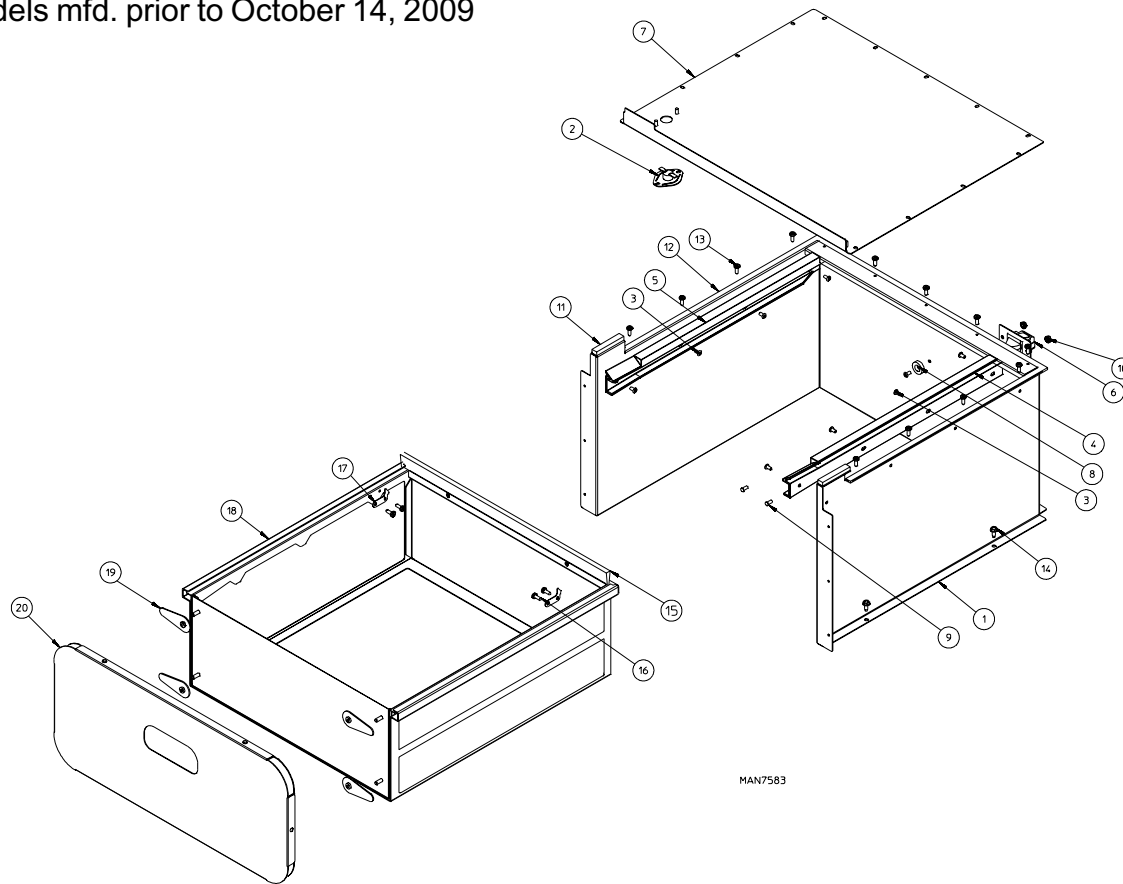

MAN7583

Illus. No.	Part No.	Qty.	Description
1	834719	1	Large Lint Box Assembly Complete
	335058	1	Large Lint Box
2	130119	1	190° Thermostat
3	154200	9	#5-32 Pop Rivet
4	185215	1	Lint Drawer Rail Right Side
5	185216	1	Lint Drawer Rail Left Side
6	819523	1	Lint Drawer Switch Assembly
	122002	1	Lint Drawer Switch ONLY
7	834720	1	Lint Box Top Assembly
8	102004	1	0.75 Round Magnet
9	153564	2	#8-32 x 0.375 Clinch Stud
10	153073	2	#8-32 Keps Nut
11	117605	2	1/4" x 3/8" Sponge Tape (sold by the foot)
12	117604	1	1/8" x 3/8" Sponge Tape (sold by the foot)
13	150331	13	#8-18 x 0.5 TORX® Screw
14	150300	7	#10-16 x 0.75 Hex Washer
15	170171	1	Lint Drawer Brush
16	150331	4	#8-18 x 0.5 TORX® Screw
17	185423	2	Lint Drawer Stop
18	834717*	1	Lint Drawer Assembly Complete (painted)
	825509	1	Lint Drawer Assembly Complete (stainless steel)
	825690	1	Lint Drawer (no handle)
19	851536	4	Lint Drawer Clinch Nut Plate
20	834718*	1	Lint Drawer Handle (painted)
	825508	1	Lint Drawer Handle (stainless steel)

* Specify color when ordering.

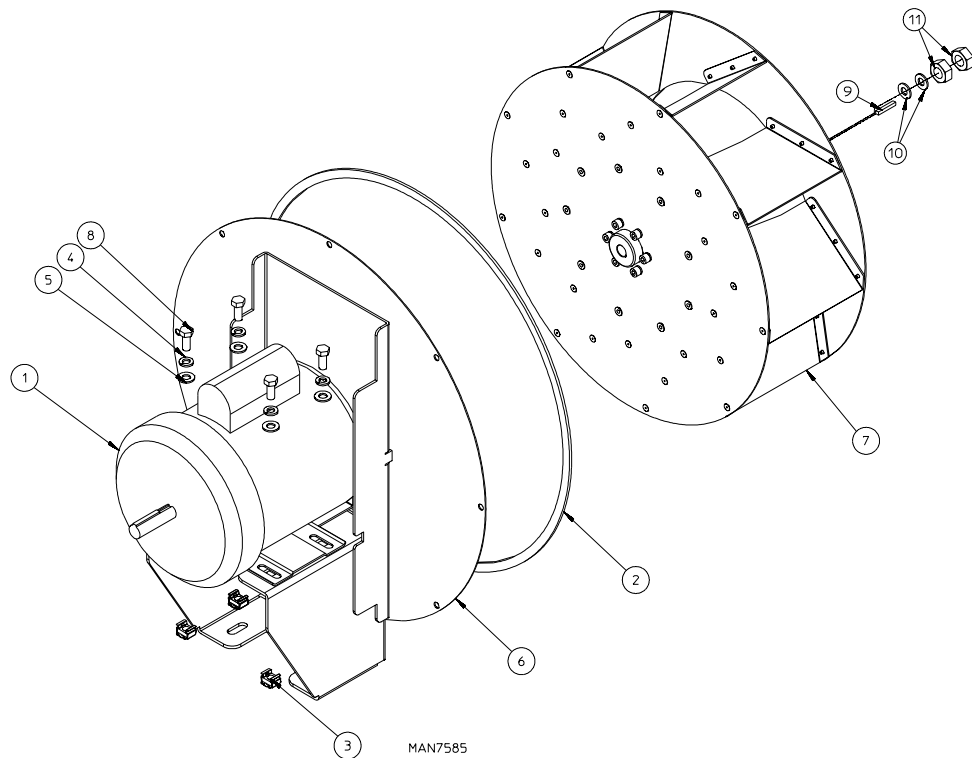

<u>Illus. No.</u>	<u>Part No.</u>	<u>Qty.</u>	<u>Description</u>
1	815248	1	Blower Motor Assembly Complete 50/60 Hz (for models mfd. as of November 18, 2010)
	181061	1	1/2 hp Blower Motor 50/60 Hz (for models mfd. as of November 18, 2010)
	834723	1	Blower Motor Assembly Complete (60 Hz) (for models mfd. prior to November 18, 2010)
	100069	1	3/4 hp Blower Motor (60 Hz) (for models mfd. prior to November 18, 2010)
	819825	1	Blower Motor Assembly (50 Hz) (for models mfd. prior to November 18, 2010)
	100068	1	3/4 hp Blower Motor (50 Hz) (for models mfd. prior to November 18, 2010)
	2	117604	1
3	154000	5	5/16-18 Tinnerman Clip
4	153002	4	5/16" Lock Washer
5	153001	4	5/16" Flat Washer
6	815249	1	Motor Mount (for models mfd. as of November 18, 2010)
	834724	1	Motor Mount (for models mfd. prior to November 18, 2010)
7	815336	1	16" Riveted Impellor (for models mfd. as of November 18, 2010)
	822364	1	16" Riveted Impellor (for models mfd. prior to November 18, 2010)
8	150501	4	5/16-18 x 3/4" Hex Bolt
9	100702	1	1/8" x 1/8" x 1-1/2" Key
10	153050	2	1/2" S.A.F.E. Flat Washer
11	152017	2	1/2-20 Left-Hand Jam Nut (for models mfd. as of November 18, 2010)
	152006	2	1/2-20 Left-Hand Jam Nut (for models mfd. prior to November 18, 2010)

60 Hz Gas Burner Assembly

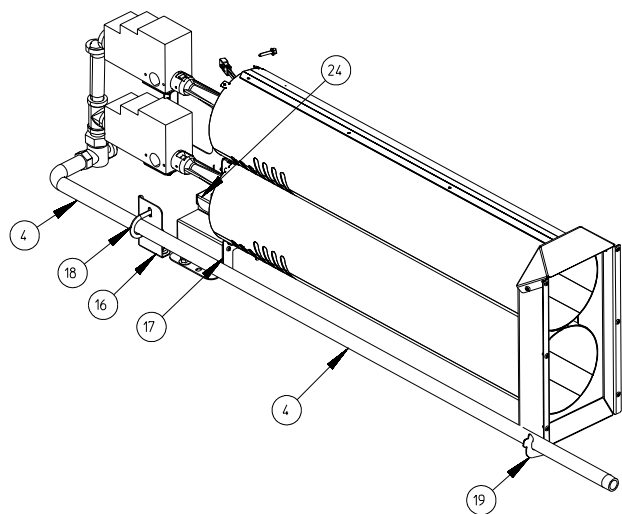

MAN7584A

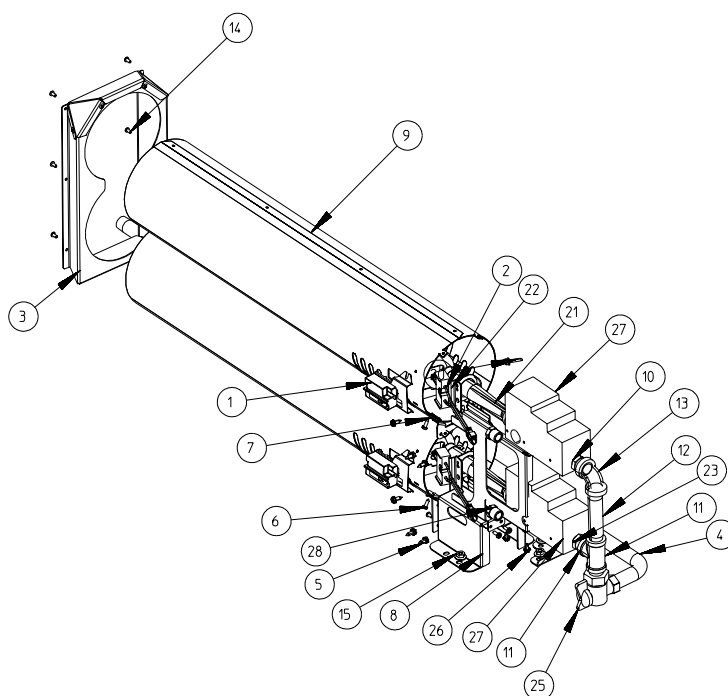

<u>Illus. No.</u>	<u>Part No.</u>	<u>Qty.</u>	<u>Description</u>
1	130500	2	Radiant Sensor
2	128910	2	Glo-Bar 80V
3	851387	1	Burner Tube Transition Assembly
4	143349	1	1/2" Gas Pipe
5	152208	6	#10-32 x 1/2" Sheet Metal Screw
6	150331	7	#8-18 x 1/2" TORX® Screw
7	350217	1	Gas Burner Funnel Support Bracket
8	350221	1	Dual Gas Burner Support Bracket
9	822357	1	Dual Gas Burner Assembly Complete
	323037	2	Round Gas Burner Tube ONLY
10	142953	2	3/8" x 1/2" Steel Bushing
11	142820	1	1/2" x 1/2" x 1/2" Gas Pipe Tee
12	142703	1	1/2" x 4" Pipe Nipple
13	142500	2	1/2" 90° Elbow
14	154200	14	5/32" Pop Rivet
15	152014	4	1/4" x 20 Free Spin Washer Nut
16	350253	1	Front Gas Pipe Bracket
17	350218	1	Gas Burner Bottom Support
19	154355	1	U-Bolt for 1/2" Gas Pipe Support
20	183145	2	Glo-Bar Mounting Screw with Washer
21	183144	2	Inshot Hot Surface Ignition Tube
22	185063	2	Hot Surface Ignition Igniter Bracket
23	183137	2	3/8" Close Nipple
24	350271	1	Dual Gas Valve Bracket
25	141321	1	1/2" N.P.T. 90° Shutoff Valve
26	152209	6	Tapping Screw
27	832206	2	Natural Gas Valve Assembly
	884378	2	Liquid Propane Gas Valve Assembly
28*	140797	2	#26 Natural Gas Orifice
	140799	2	#42 Liquid Propane Gas Orifice
	887260	1	Liquid Propane Conversion Kit

* Consult factory for elevation over 2,000 feet for correct burner orifice size.

50 Hz Gas Burner Assembly

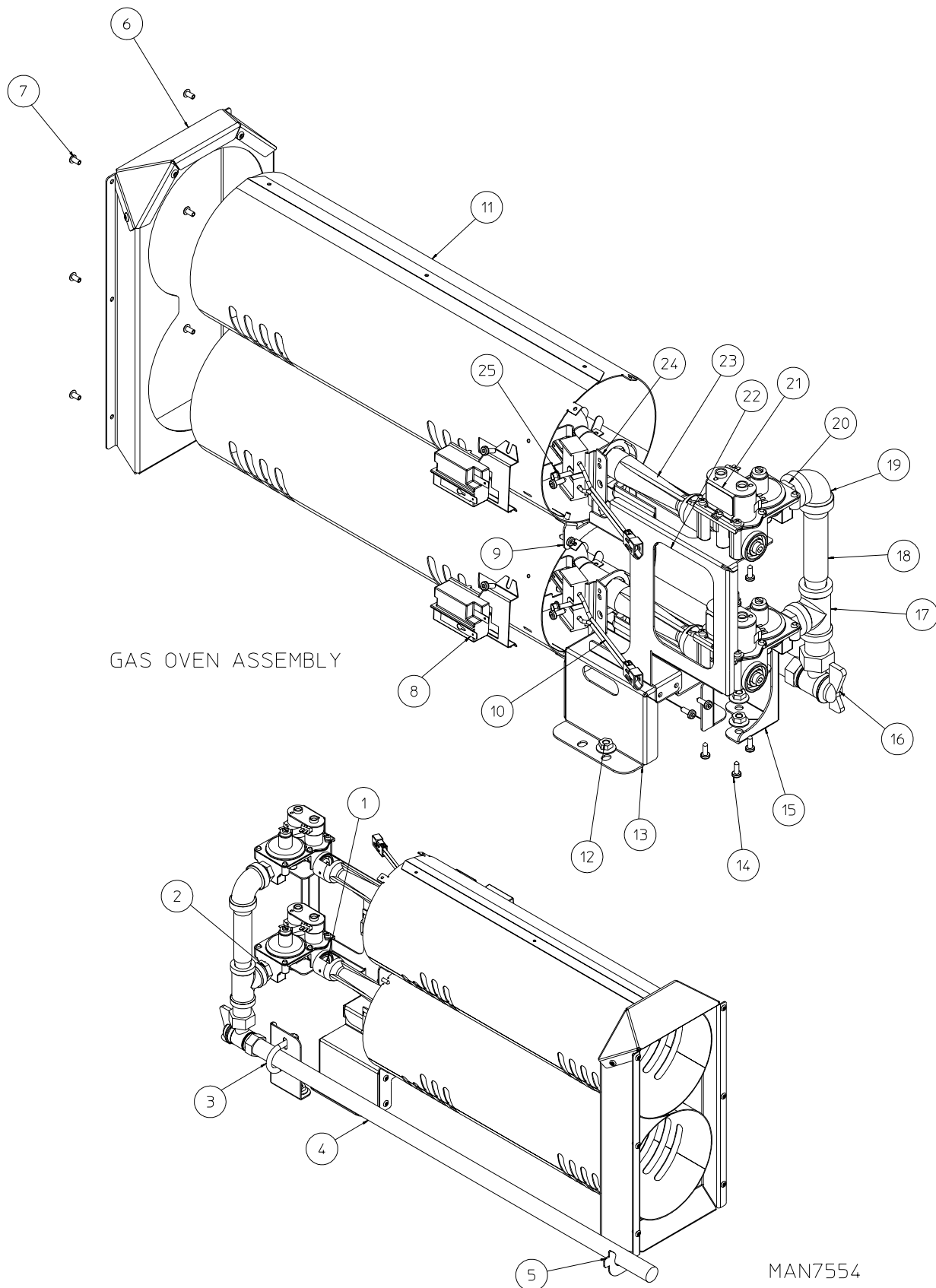

<u>Illus. No.</u>	<u>Part No.</u>	<u>Qty.</u>	<u>Description</u>
1*	140880	2	#22 Natural Gas Orifice
	140905	2	#44 Liquid Propane Orifice
	884249	1	Liquid Propane Conversion Kit
2	183137	2	3/8" Close Nipple Black Iron
3	154355	1	U-Bolt with Nuts for 1/2" Black Pipe
4	143352	1	1/2" x 42" Black Pipe ONLY
5	350226	1	Rear Gas Pipe Support
6	851387	1	Burner Funnel Transition Assembly
7	154200	14	5/32 Pop Rivet
8	130500	2	Radiant Heat Sensor
9	350217	1	Burner Funnel Top Lip Bracket
10	128910	2	Hot Surface Ignitor
11	851391	1	50 Hz Natural Gas Dual Burner Assembly
	350223	2	Round Gas Burner Funnel ONLY
12	152014	4	1/4-20 Free Spin Nut
13	350221	1	Dual Round Gas Burner Support Bracket
14	150331	19	#8-18 x 1/2" Pan Head TORX® Screw
15	350253	1	Front Gas Pipe Bracket
16	881367	1	Gas Shutoff Assembly
17	142820	1	1/2" x 1/2" x 1/2" Black Iron Tee
18	142703	1	1/2" x 4" Black Iron Pipe
19	142500	1	1/2 - 90° Elbow
20	142953	2	3/8" x 1/2" Steel Bushing
21	128907	2	25M Gas Valve 120 VAC 50 Hz
22	350220	1	Dual Gas Valve Bracket
23	183144	2	In-Shot Tube
24	185063	2	Ignitor Bracket
25	183145	2	Hot Surface Ignitor Mounting Screw

* Consult factory for elevation over 2,000 feet for correct burner orifice size.

Steam Coil / Electric Oven Assembly

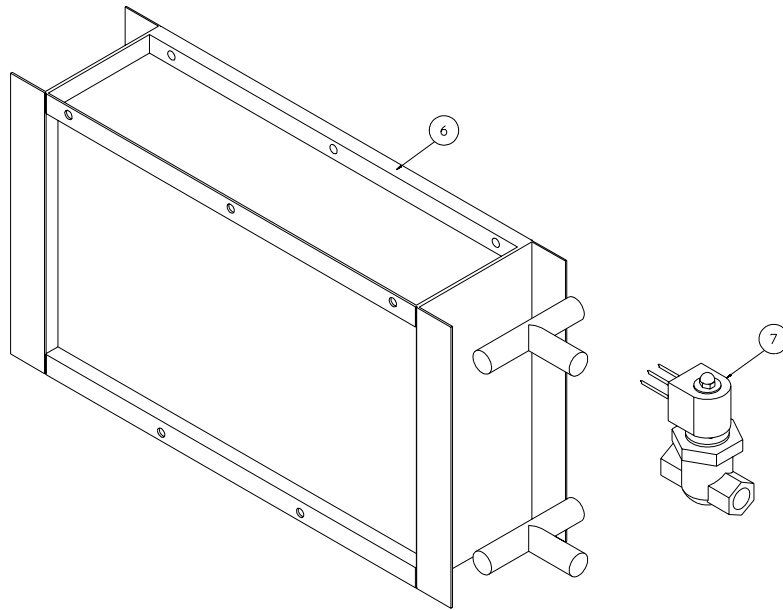

STEAM COIL ASSEMBLY

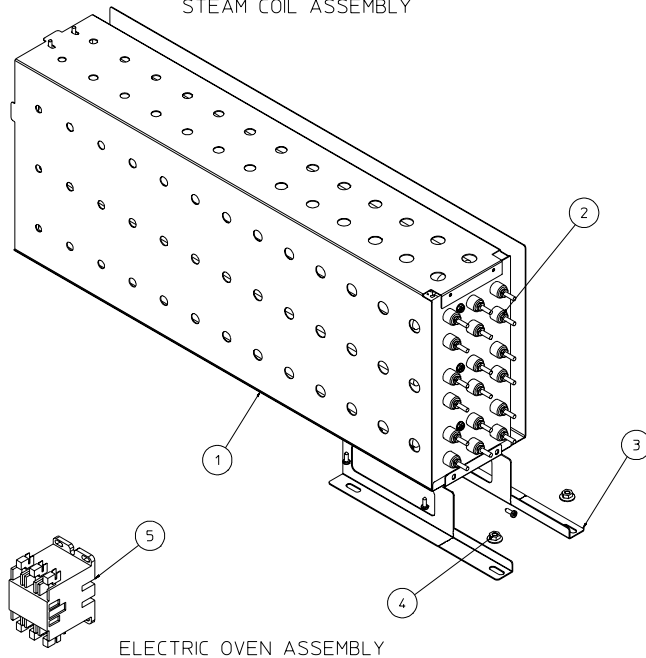

ELECTRIC OVEN ASSEMBLY

MAN7555A

<u>Illus. No.</u>	<u>Part No.</u>	<u>Qty.</u>	<u>Description</u>
1	851396	1	Electric Oven Assembly 200-415V
2	119997	1	22 kW Element
3	350230	1	Electric Oven Support Bracket
4	152014	2	Free Spin Wash Nut
5	131322	1	208/240V 30A Contactor 50/60 Hz
	131324	1	208/240V 40A Contactor 50/60 Hz
	131326	1	208/240V 50A Contactor 50/60 Hz
	131328	1	208/240V 60A Contactor 50/60 Hz
	131330	1	208/240V 75A Contactor 50/60 Hz
6	165067	1	Copper Steam Coil
7	813415	1	Steam Solenoid Phase 8 Assembly 120V (60 Hz)
	813416	1	Steam Solenoid Phase 8 Assembly 220-240V (50/60 Hz)

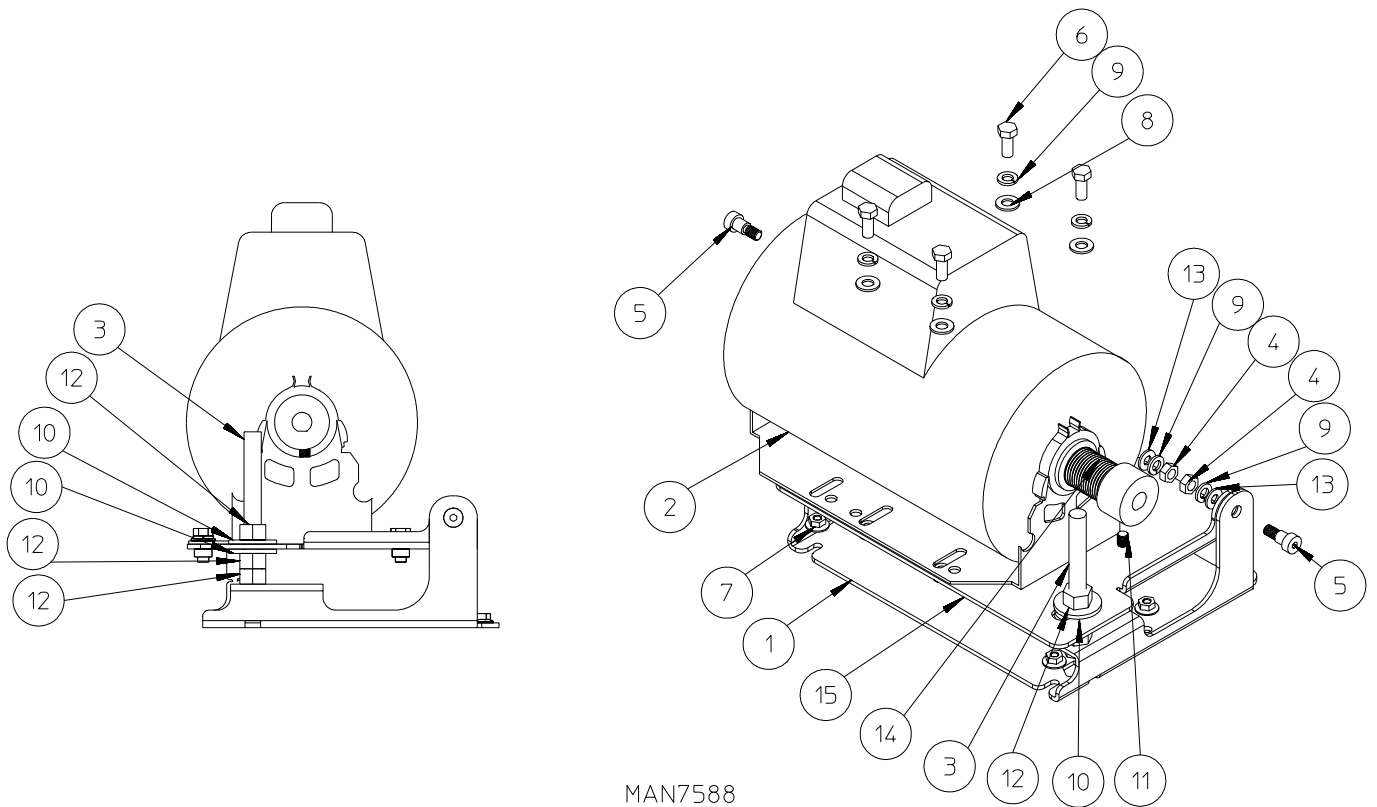

MAN7588

Illus. No.	Part No.	Qty.	Description
1	350301	1	Motor Mount Base Plate
2	819594	1	Drive Motor Assembly Complete (60 Hz)
	887221	1	Drive Motor with Sheave (60 Hz)
	819824	1	Drive Motor Assembly Complete (50 Hz)
	887222	1	Drive Motor with Sheave (50 Hz)
3	150609	1	1/2-13 x 4-1/2" Tap Bolt
4	152004	2	5/16-18 Hex Nut
5	154266	2	3/8" x 3/8" Shoulder Screw
6	150501	4	5/16-18 x 3/4" Tap Bolt Hex Head
7	152014	5	1/4-20 Free Spin Wash Nut
8	153001	4	5/16" Flat Washer
9	153002	6	5/16" Split Lock Washer
10	153033	2	1/2" x 1-3/8" Flat Washer
11	154321	1	5/16-24 x 3/8" Alan Setscrew
12	152011	3	1/2-13 Hex Nut
13	153018	2	1/4" Flat Washer
14	323373	1	60 Hz Motor Sheave
	350004	1	50 Hz Motor Sheave
15	851543	1	Motor Platform Assembly
	102415	1	15 Rib Drive Belt ... Not Illustrated

Sail Switch Assembly

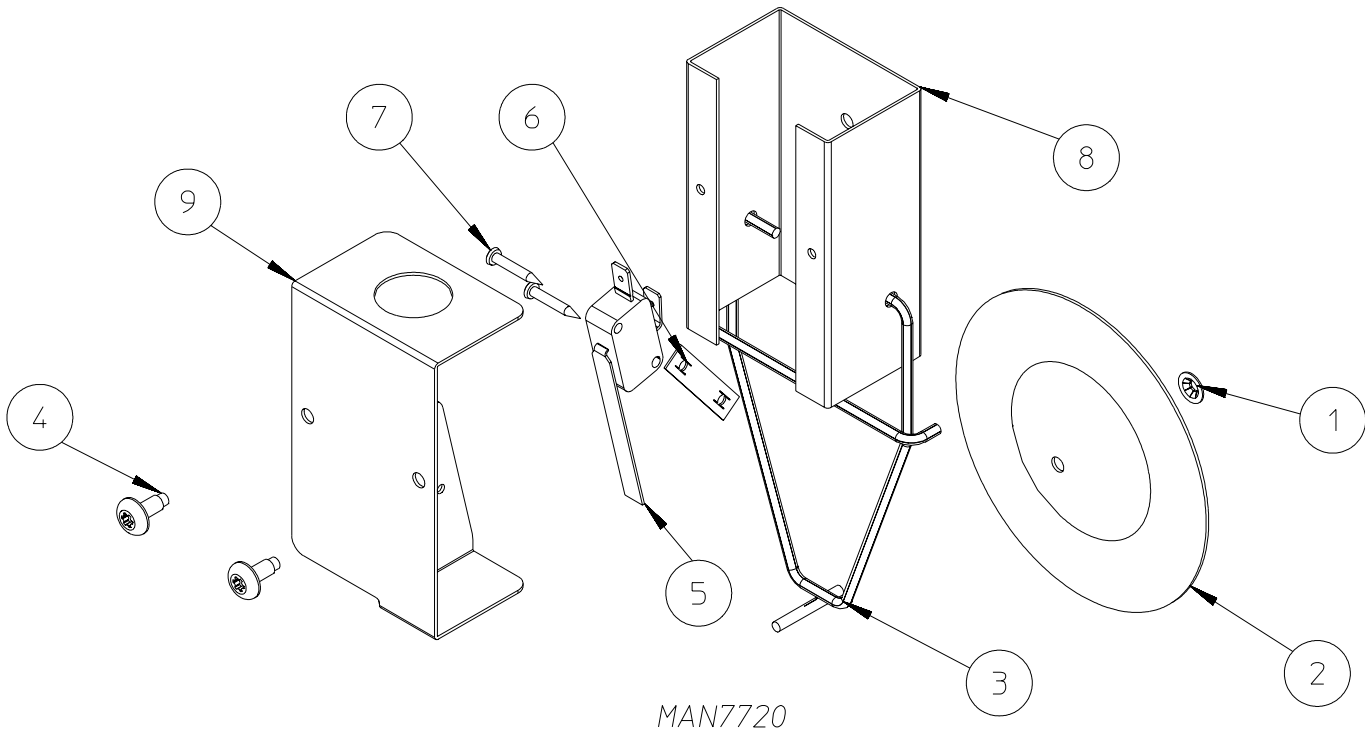

<u>Illus. No.</u>	<u>Part No.</u>	<u>Qty.</u>	<u>Description</u>
1	154002	1	1/8" Push-On Fastener
2	319206	1	Sail Switch Damper (embossed)
3	105500	1	Sail Switch Actuator Rod
4	150313	2	#10-16 x 1/2" TORX Plus® Screw
5	122200	1	Sail Switch
6	154004	1	Speed Nut
7	150303	2	#4 x 3/4" Phillips Screw
8	318237	1	Sail Switch Box
	818570	1	Sail Switch Assembly (includes illus. nos. 1 through 9)
9	350283	1	Sail Switch Box Cover

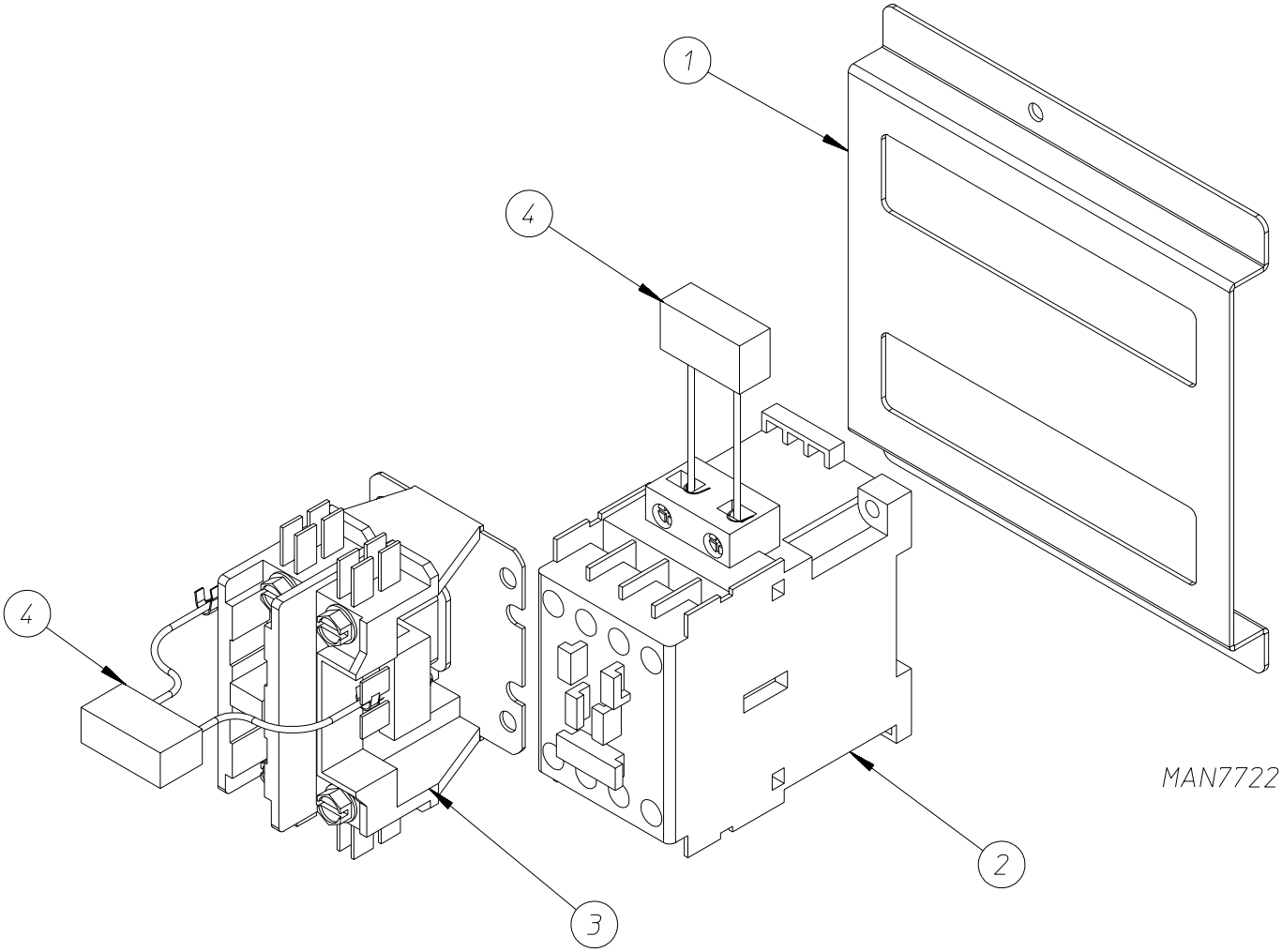

MAN7722

<u>Illus. No.</u>	<u>Part No.</u>	<u>Qty.</u>	<u>Description</u>
1	317052	1	Contactor Bracket
2	132414	1	Reversing Contactor 120V
	131818	1	Reversing Relay 208-240V
3	132652	1	Blower Contactor 120V
4	824828	2	RC Network

Fire Suppression System

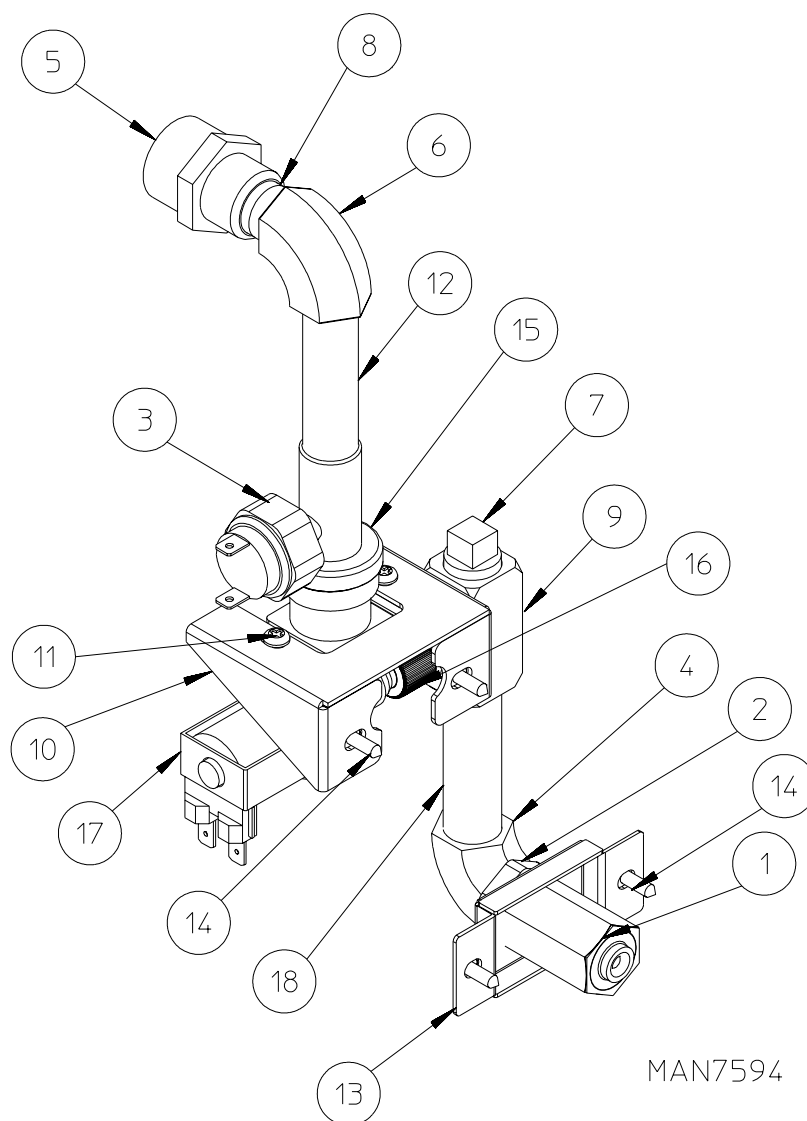

MAN7594

<u>Illus. No.</u>	<u>Part No.</u>	<u>Qty.</u>	<u>Description</u>
1	143581	1	3 GPM 3/8" N.P.T. Spray Nozzle
2	143303	1	3/8" N.P.T. Brass Lock Nut
3	136987	1	Water Jet Pressure Switch
4	143155	1	3/8" Brass Street Elbow
5	143025	1	3/4-11 NH x 3/8" N.P.T. Nylon Hose Adapter
6	143310	1	3/8" Brass 90° Elbow
7	143251	1	3/8" M.P.T. Brass Plug
8	143241	1	3/8" x Close Brass Nipple
9	143220	1	3/8" F.P.T. Brass Tee
10	319231	1	Water Valve Bracket
11	154338	2	M4 x 6mm Phillips Head Slotted Machine Screw
12	143242	1	3/8" x 2-1/2" Brass Nipple
13	318422	1	Spray Nozzle Bracket
14	150331	4	#8-18 x 1/2" Pan Head TORX® Screw
15	143182	1	3/4" GHT x 1/8" x 3/8" N.P.T. Brass Tee
16	143183	1	7/16-20 x 3/8" N.P.T. Brass Adapter
17	165120	1	Water Inlet Valve 24VDC
18	143323	1	3/8" x 3" Brass Nipple

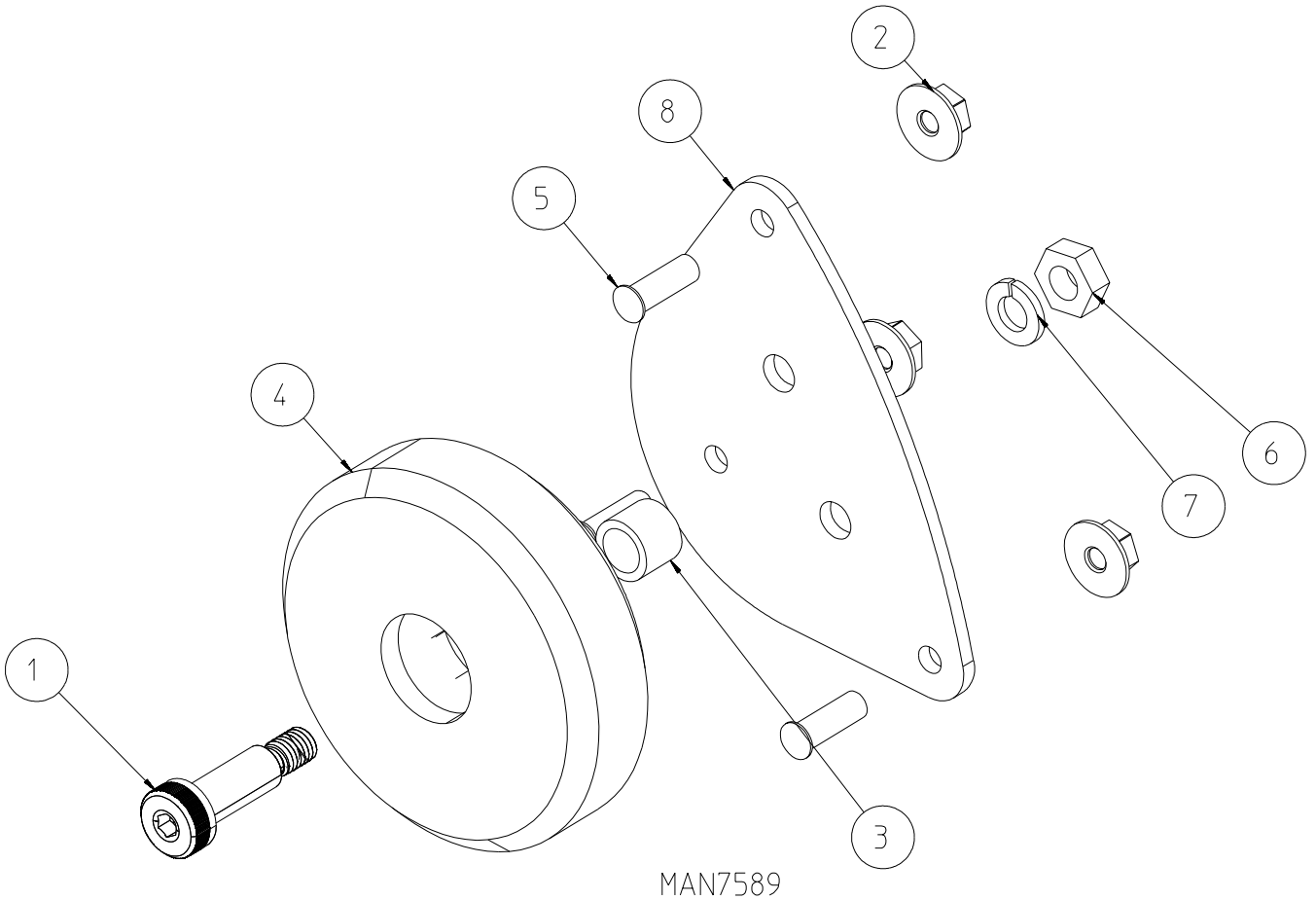

Illus. No.	Part No.	Qty.	Description
1	154264	1	10 M8 x 25mm Shoulder Bolt
2	152014	3	1/4-20 Free Spin Wash Nut
3	154284	1	Tumbler Wheel Spacer
4	180060	1	3-1/2" Tumbler Support Wheel
5	153557	3	1/4-20 x 3/4" Self-Clinching Stud
6	154013	1	M8 Hex Nut
7	153002	1	5/16" Lock Washer
8	350196	1	1/2" Wheel Bracket
	851529	1	Front Wheel Assembly Complete
	851530	1	Rear Wheel Assembly Complete ... Not Illustrated
	350198	2	Rear Wheel Bracket Shim ... Not Illustrated (rear Only)

Duplicate all parts for rear wheel assembly.

Transformer Assembly

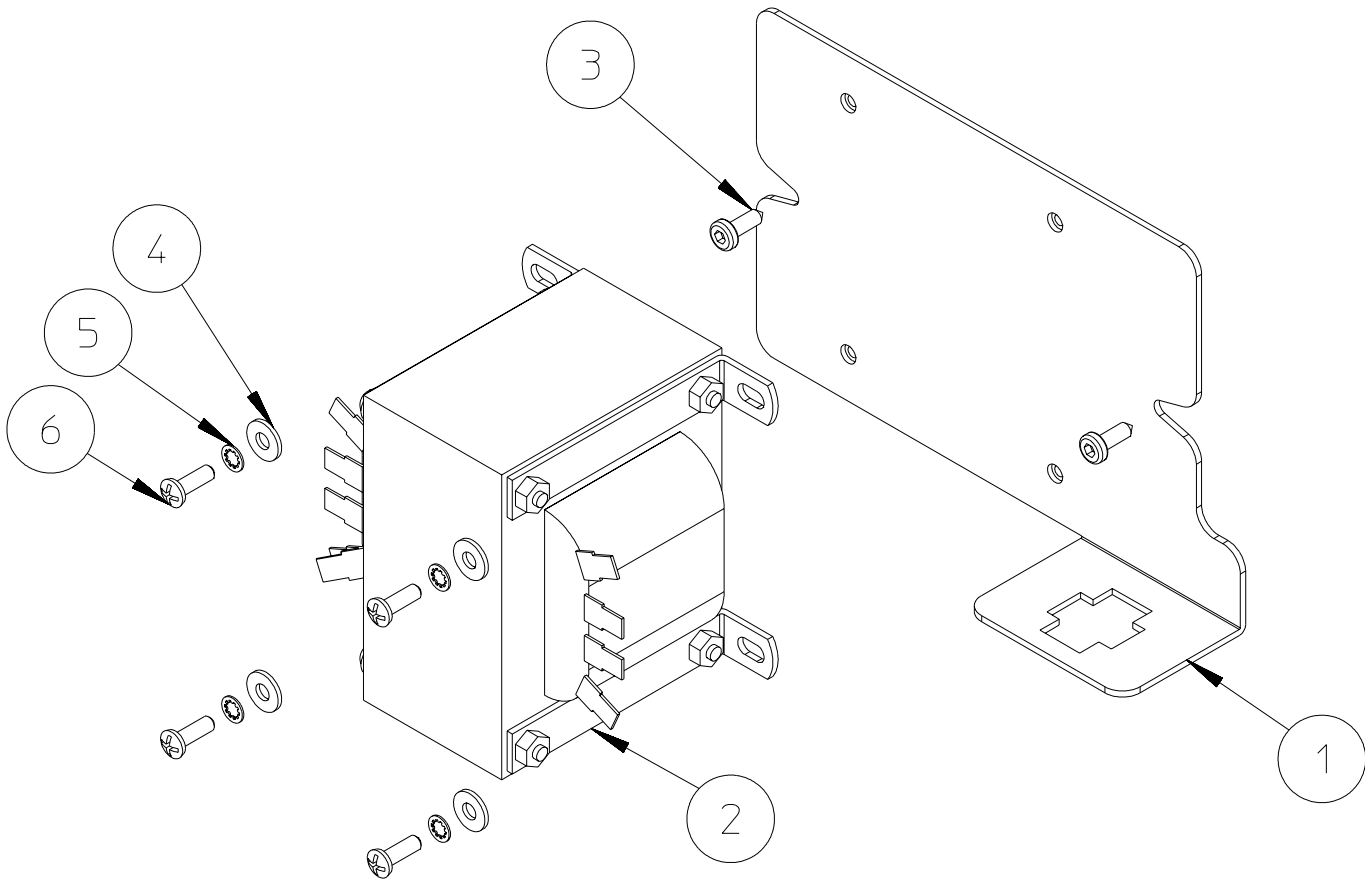

MAN7726

<u>Illus. No.</u>	<u>Part No.</u>	<u>Qty.</u>	<u>Description</u>
1	851451	1	Transformer Mounting Plate
2	132029	1	208-240 Volt to 120 Volt Auto Transformer
	851519	1	208-240 Volt to 120 Volt Transformer Assembly (includes illus. nos. 1 through 6)
3	150331	2	#8-18 x 1/2" Pan Head TORX® Screw
4	153000	4	#8 Flat Washer
5	153012	4	#8 Star Washer
6	150108	4	#8-32 x 1/2" Phillips Pan Head Screw

