

DRYER

Repair Parts List

MODEL NUMBER

MDE13CSACW

DDSPARTS.COM

When requesting service or ordering parts, always provide the following information:

- Product Type
- Part Number
- Model Number
- Part Description

MAYTAG®

©2005 Maytag Services

Section: CONTROL CENTER SHROUD

Model: MDE13CSACW

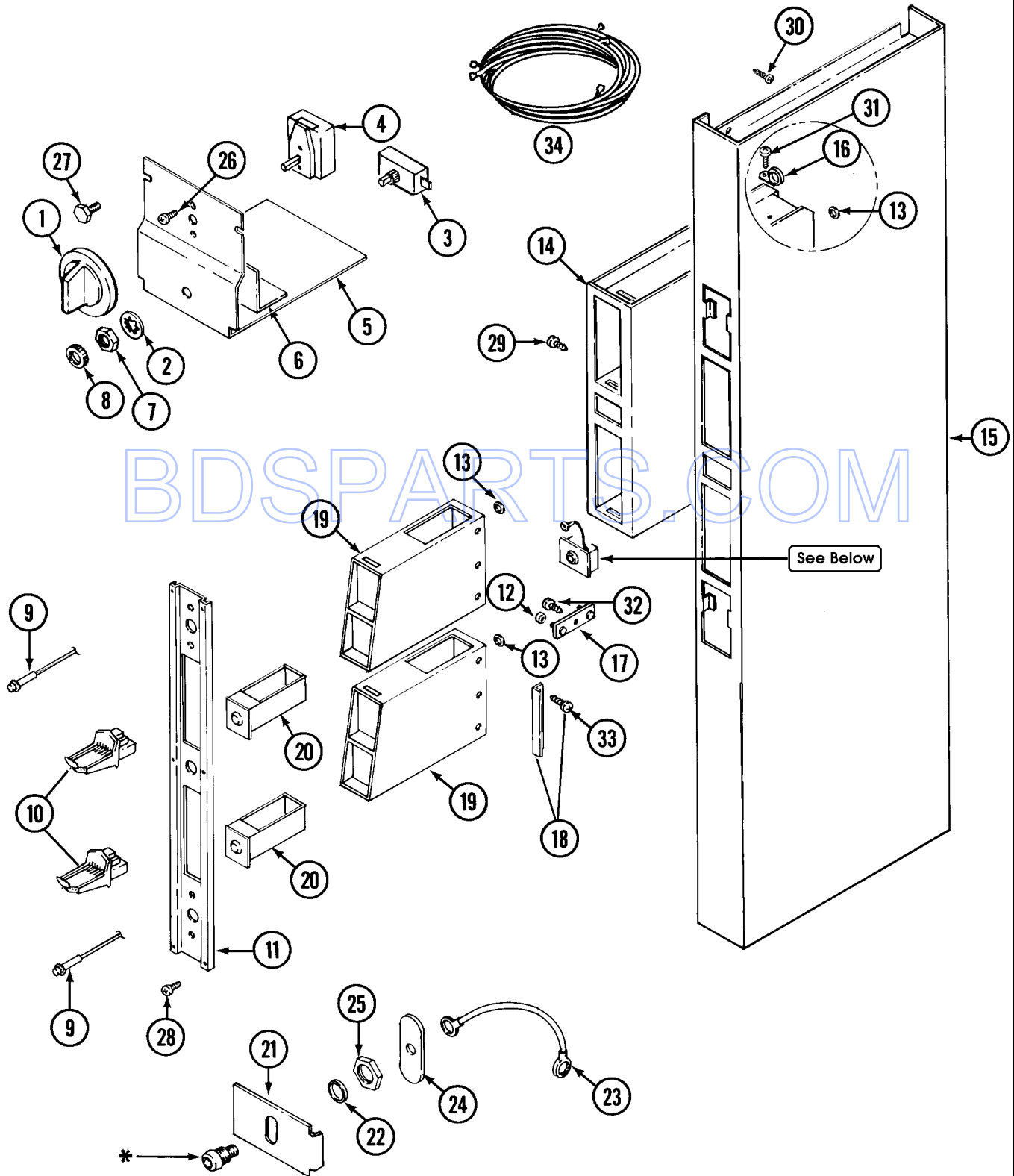

* Contact your Commercial Distributor For Security Items.

Section: CONTROL CENTER SHROUD

No.	Part No.	Description	Series	Qty
1	205663	KNOB FOR SELECTOR SWITCH Note: KNOB, SELECTOR SWITCH	10	2
2	312751	LOCK WASHER Note: LOCKWASHER, START SWITCH	10	2
3	306940	SWITCH, PUSH-TO-START	10	2
4	307253	SWITCH CYCLE SEL Note: SWITCH, CYCLE SELECTOR	10	2
5	314261	SWITCH AND RELAY BRACKET Note: BRACKET, SWITCH & RELAY	10	2
6 N	313423	INSULATOR Note: INSULATOR, SWITCH	10	2
7	312706	HEX NUT ON SWITCH Note: NUT, SWITCH	10	2
8	312702	KNURLED NUT Note: KNURLED NUT, START SWITCH	10	2
9	303963	INDICATOR LIGHT Note: LIGHT, INDICATOR	10	2
10 N	205470	MAYTAG COIN SLIDE Note: SLIDE, MAYTAG COIN	10	2
11 N	33001719	PANEL, VAULT	10	1
12	052740	NUT Note: NUT, CONTROL CENTER	10	2
13	313671	GROMMET FOR CONTROL CENTER Note: GROMMET, WIRE HARNESS	10	3
14	305534	VAULT ASSEMBLY Note: VAULT ASSEMBLY	10	1
-	211294	SCREW Note: SCREW, VAULT	10	3
-	313559	SCREW Note: SCREW, VAULT	10	1
15 N	305535	CONTROL SHROUD-WHITE Note: SHROUD, CONTROL (WHT)	10	1
-	211294	SCREW Note: SCREW, CONTROL ASSEMBLY	10	4
-	210587	SCREW Note: SCREW, SHROUD	10	6
16	910768	CABLE STRAP-HARNESS TO BASE Note: STRAP, CABLE	10	1
17	22001810	STRAP, MOUNTING	10	1
18 N	305160	COIN METER STOP WITH SCREWS Note: STOP, COIN METER	10	4
19 N	307081	COIN METER WELD ASSEMBLY Note: CASE, COIN METER (WHT)	10	2
20	205423	COIN BOX-WHITE Note: BOX, COIN (WHT)	10	2
21	313428	PLATE FOR LATCH Note: PLATE, LATCH	10	1
22 N	213626	SPRING WASHER FOR LOCK Note: WASHER, LATCH	10	1
-	211168	SCREW, #8 X 5/16 INCH Note: SCREW, GROUND WIRE	10	1
23	303981	GROUND WIRE FOR LATCH Note: GROUND WIRE, LATCH	10	1
24	313427	LATCH FOR COVER PLATE Note: LATCH, COVER PLATE	10	1
25	212328	NUT, HEX Note: NUT, LOCK ASSEMBLY	10	1
26	313588	SCREW Note: SCREW, SELECTOR SWITCH	10	4
27	212276	SCREW Note: SCREW, SWITCH & RELAY BRACKET	10	4
28	313424	SCREW Note: SCREW, VAULT PANEL	10	6
29	211294	SCREW Note: SCREW, VAULT	10	3
29	313559	SCREW Note: SCREW, VAULT	10	1
30	213648	SCREW, HEX HD #8 X 5/8 Note: SCREW, SHROUD	10	2
31	211168	SCREW, #8 X 5/16 INCH Note: SCREW, CABLE STRAP	10	1
32	212276	SCREW Note: SCREW, MOUNTING STRAP	10	2
33	014872	SCREW, #10 X 3/8 Note: SCREW, COIN METER STOP	10	12
34	33001516	HARNESS, WIRE (LOWER) Note: (LWR)	10	1
34	33001515	HARNESS, WIRE (UPPER) Note: WIRE HARNESS, MAIN (UPR)	10	1

*Color Code (-)=Not Shown #=Series, Serial Prefix or Run No., N=Not Available

Section: CONTROL CENTER

Model: MDE13CSACW

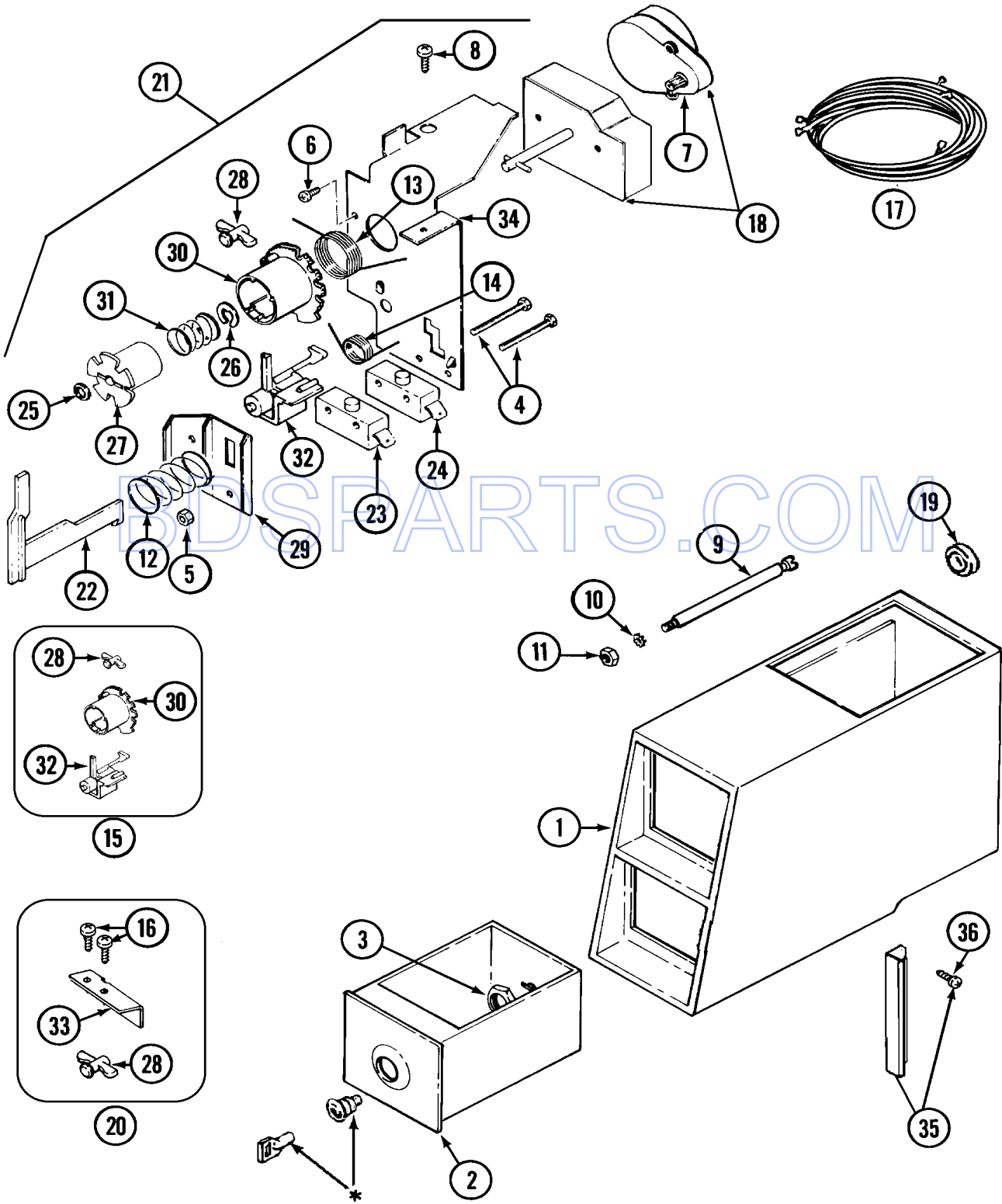

* CONTACT YOUR COMMERCIAL LAUNDRY DISTRIBUTOR

CD11-21

Section: CONTROL CENTER

No.	Part No.	Description	Series	Qty
1	N 307081	COIN METER WELD ASSEMBLY Note: CASE, COIN METER (WHT)	10	2
2	205423	COIN BOX-WHITE Note: BOX, COIN (WHT)	10	2
3	212328	NUT, HEX Note: LOCK NUT ASSEMBLY	10	2
4	315277	SCREW Note: SCREW, BY-PASS SWITCHES	10	4
5	052634	HEX. NUT, #6-32 Note: NUT, BY-PASS SWITCHES	10	4
6	910708	SCREW -RELAY TO TUB SUPPORT Note: SCREW, TIMER	10	4
7	305870	TIMER MOTOR RPR Note: MOTOR, TIMER	10	2
8	211168	SCREW, #8 X 5/16 INCH Note: SCREW, TIMER BRACKET	10	2
9	215559	BOLT, LOCKING Note: BOLT, LOCKING	10	2
10	910387	LOCK WASHER Note: LOCKWASHER, LOCKING BOLT	10	2
11	052721	NUT Note: NUT, LOCKING BOLT	10	2
12	314340	HELICAL SPRING Note: SPRING, HELICAL	10	2
13	314331	RETURN SPRING Note: SPRING, TORSION RETURN	10	2
14	314332	ACTUATOR SPRING Note: SPRING, ACTUATOR	10	2
15	306104	TORSION-TIMER KIT Note: ACTUATOR KIT	10	2
16	212707	SCREW Note: SCREW, SLIDE BRACKET	10	4
17	305800	WIRE HARNESS FOR TIMER Note: WIRE HARNESS, TIMER	10	2
18	305796	TIMER	10	2
19	313671	GROMMET FOR CONTROL CENTER Note: GROMMET, CASE OPENING	10	2
20	308109	BRACKET FOR SLIDE & ADJ RTN ST Note: SLIDE & ADJ. RETURN BRACKET	10	2
21	305797	TORSION TIMER ASSM COMPLETE Note: TORSION TIMER ASSEMBLY	10	2
22	314337	SLIDER	10	2
23	305798	BYPASS SWITCH FOR MOTOR Note: SWITCH, BY-PASS (MOTOR)	10	2
24	305799	BYPASS SWITCH FOR HEATER Note: SWITCH, BY-PASS (HEATER)	10	2
25	211790	LOCK RING FOR TIMER SHAFT Note: RETAINER, SPRING	10	2
26	312270	E CLIP Note: CLIP, SPRING RETAINER	10	2
27	314330	DRIVER FOR INDEX WHEEL Note: DRIVER, INDEX WHEEL	10	2
28	314547	ADJUSTMENT RETURN STOP Note: STOP, ADJUSTABLE RETURN	10	4
28	314335	TIME ADJUSTMENT PEG Note: PEG, TIME ADJUSTMENT	10	2
29	314339	SWITCH AND SLIDER BRACKET Note: BRACKET, SWITCH & SLIDER	10	2
30	314546	INDEX WHEEL Note: WHEEL, INDEX	10	2
31	211065	SPRING, TIMER KNOB Note: SPRING, INDEX WHEEL	10	2
32	314548	ACTUATOR, SWITCH Note: ACTUATOR, SWITCH	10	2
33	314334	BRACKET FOR COIN SLIDE Note: BRACKET, COIN SLIDE	10	2
34	314333	TIMER MOUNTING BRACKET Note: BRACKET, TIMER	10	2
35	N 305160	COIN METER STOP WITH SCREWS Note: STOP, COIN METER	10	4
36	014872	SCREW, #10 X 3/8 Note: SCREW, METER STOP	10	12

*Color Code (-)=Not Shown #=Series, Serial Prefix or Run No., N=Not Available

Section: FRONT

Model: MDE13CSACW

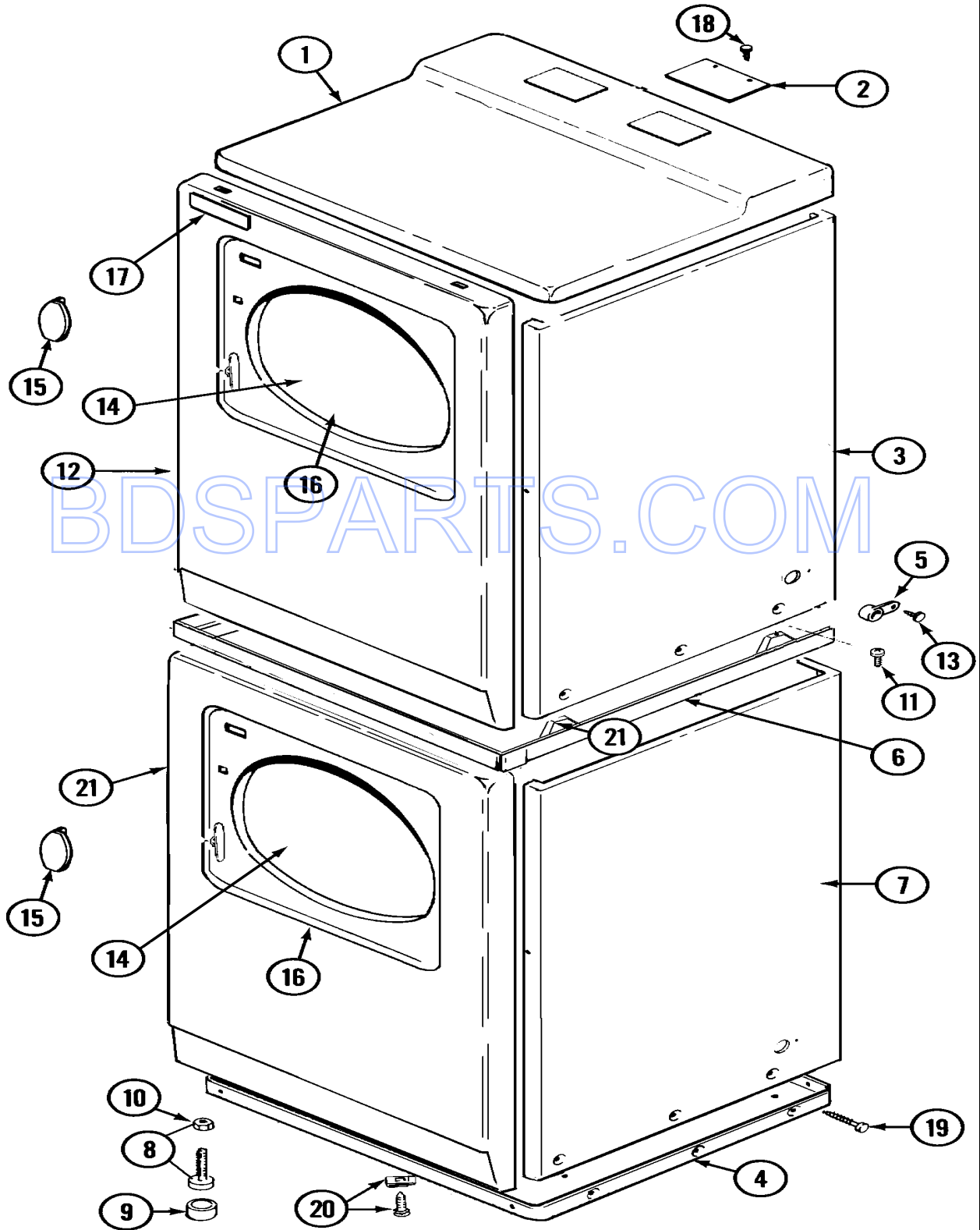

CD13-3

Section: FRONT

No.	Part No.	Description	Series	Qty
1	N 33001608	COVER, TOP (WHT)	10	1
2	N 314943	COVER PLATE Note: PLATE, COVER	10	2
3	N 33001298	CABINET, STACK (UPPER-WHT) COM Note: (UPR-WHT)	10	1
4	306530	BASE WELD ASSEMBLY Note: BASE ASSEMBLY	10	2
5	910768	CABLE STRAP-HARNESS TO BASE Note: STOP, CABLE	10	2
-	911050	SCREW Note: SCREW, SPACER ASSEMBLY	10	1
-	310632	SCREW Note: SCREW, SPACER ASSEMBLY	10	5
6	33001302	SPACER ASSY. (WHT) Note: (WHT)	10	1
7	N 33001300	CABINET, STACK (LOWER-WHT) Note: (LWR-WHT)	10	1
8	302699	LEG, ADJUSTABLE (W/NUT)	10	4
9	210684	FOOT, RUBBER	10	2
10	210385	NUT, LOCK Note: NUT, ADJUSTABLE LEG	10	4
11	314663	SCREW Note: SCREW, TOP DRYER	10	4
12	N 33001610	PANEL, FRONT (WHT)----NA	10	2
-	33001486	PANEL, FASTENER	10	8
13	211168	SCREW, #8 X 5/16 INCH Note: SCREW, CABLE STRAP	10	2
14	33001203	PANEL, INNER (W/SEAL) Note: PANEL, CLEAR INNER (W/SEAL)	10	2
15	314939	HANDLE Note: HANDLE, DOOR (WHT)	10	2
16	314967	DOOR W/WIN CUT OUT OUTER WHT Note: PANEL, OUTER (WHT)	10	2
17	33001711	NAMEPLATE	10	1
18	313559	SCREW Note: SCREW, COVER PLATE	10	2
19	213007	SCREW, CABINET Note: SCREW, CABINET SIDES	10	12
20	22001496	SCREW, TORX Note: SCREW, FRONT PANEL	10	4
21	310933	FASTENER Note: FASTENER, SUPPORT ASSEMBLY	10	4

*Color Code (-)=Not Shown #=Series, Serial Prefix or Run No., N=Not Available

Section: DOOR

Model: MDE13CSACW

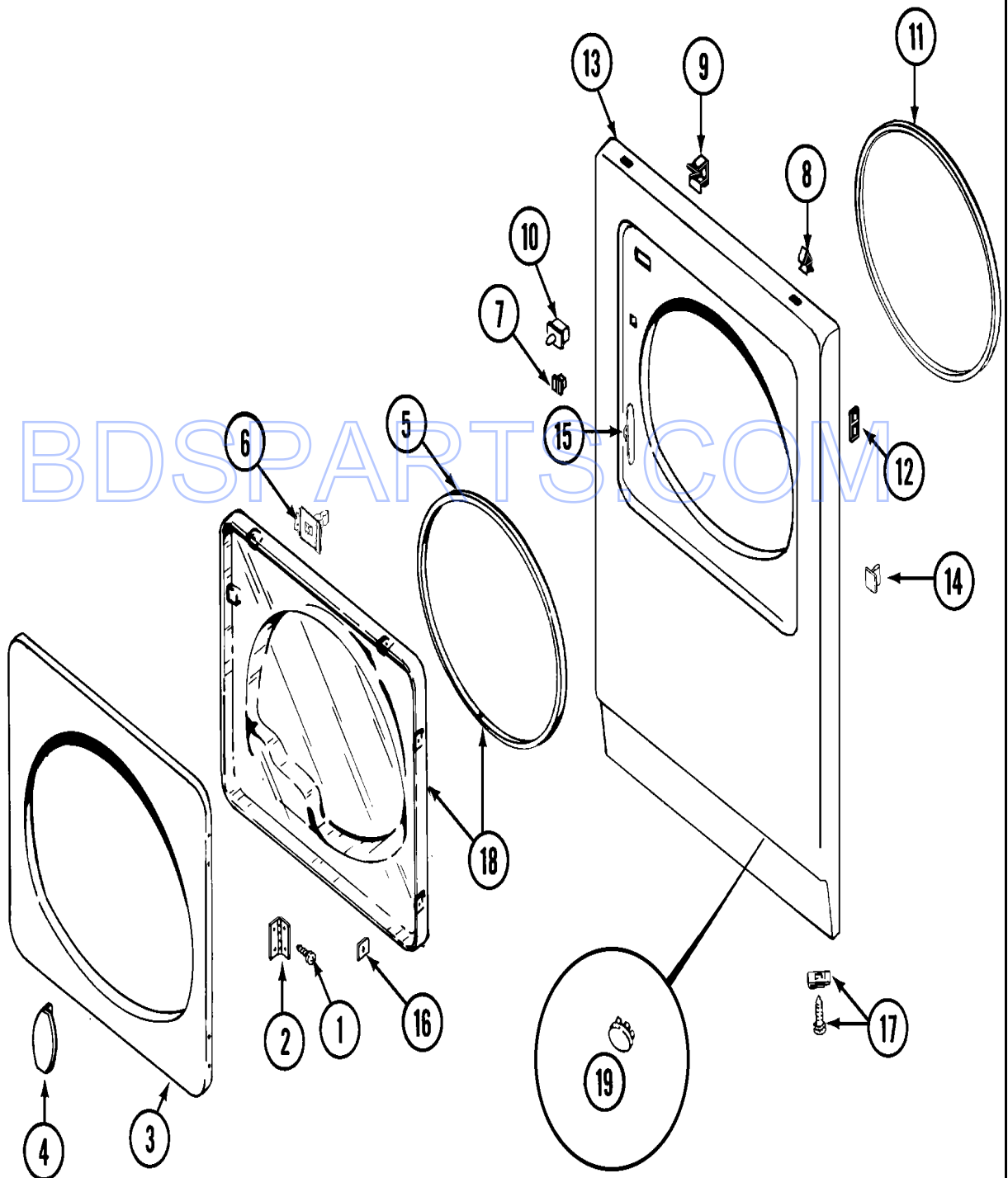

CD12-2

Section: DOOR

No.	Part No.	Description	Series	Qty
1	314062	SCREW Note: SCREW, DOOR HINGE & PANEL	10	28
2	33001230	HINGE, DOOR	10	4
3	314967	DOOR W/WIN CUT OUT OUTER WHT Note: PANEL, OUTER (WHT)	10	2
4	314939	HANDLE Note: HANDLE, DOOR (WHT)	10	2
5	33001192	SEAL, DOOR	10	2
6	33001305	STRIKE, DOOR (W/BRACKET)	10	2
7	304578	CATCH, DOOR (FEMALE)	10	2
8	212982	FASTENER, PANEL Note: FASTENER, SPRING	10	4
9	310376	CLIP, WIRE HARNESS Note: CLIP, CABLE	10	2
10	33001509	SWITCH, DOOR	10	2
11	314937	SEAL, FRONT PANEL	10	2
-	N 33001172	SCREW, PLASTIC	10	8
12	N 33001173	NUT, SPEED Note: SPEEDNUT, HINGE SCREW	10	8
13	N 33001610	PANEL, FRONT (WHT)----NA	10	2
-	33001486	PANEL, FASTENER	10	8
14	N 33001174	PLUG, DOOR CATCH	10	2
15	33001175	COVER, HINGE HOLE (WHT)	10	4
16	313910	CLIP, DOOR LINER TO OUTER PNL Note: FASTENER, INNER DOOR	10	18
17	22001496	SCREW, TORX Note: SCREW, FRONT PANEL	10	2
18	33001203	PANEL, INNER (W/SEAL) Note: PANEL, CLEAR INNER (W/SEAL)	10	2
19	33001614	PLUG, FRONT PANEL (WHT)	10	2

BDSPARTS.COM

*Color Code (-)=Not Shown #=Series, Serial Prefix or Run No., N=Not Available

Section: REAR

Model: MDE13CSACW

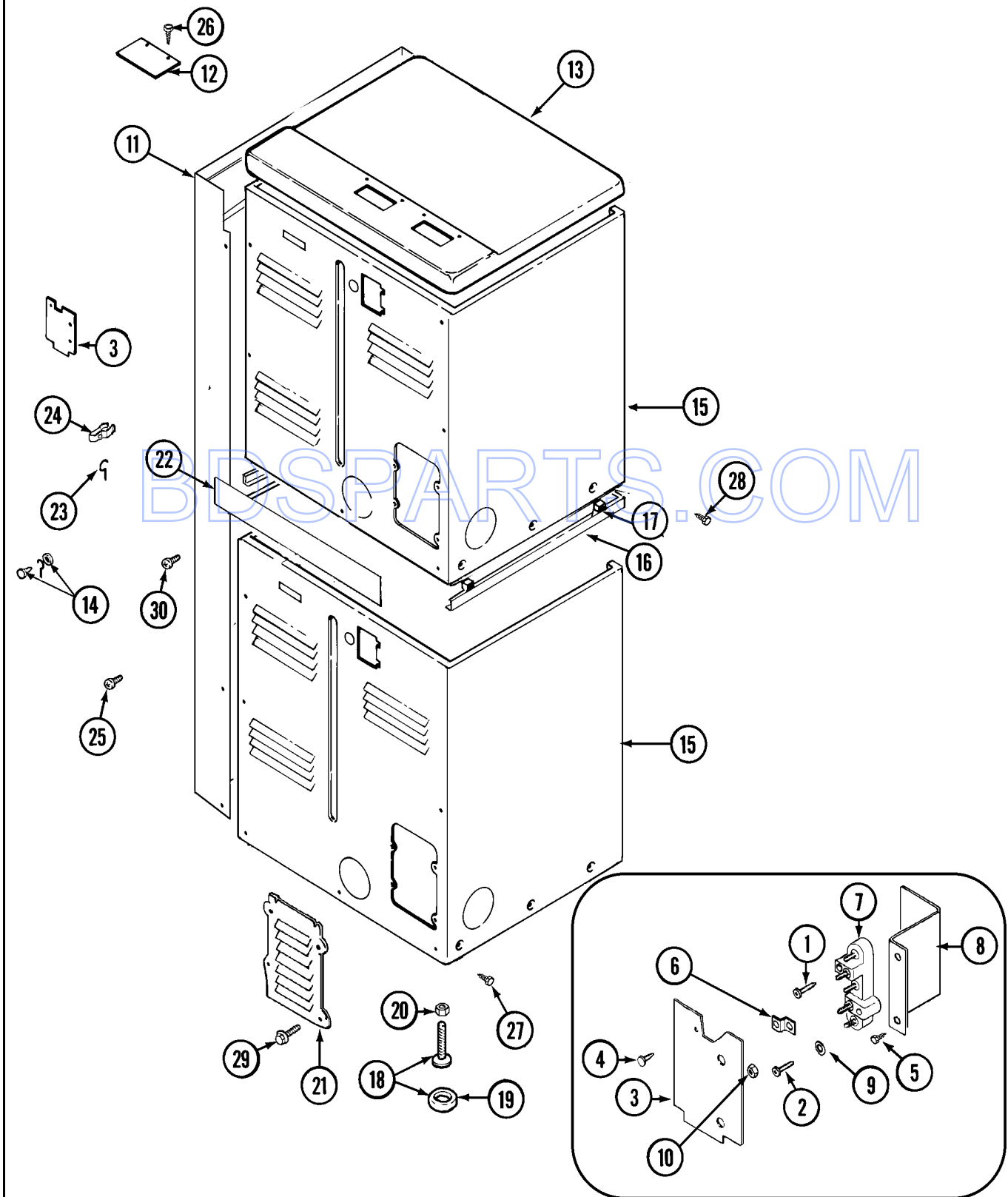

CD18-2

Section: REAR

No.	Part No.	Description	Series	Qty
1	N 33001245	SCREW----NA Note: SCREW, GROUND STRAP	10	2
2	310632	SCREW Note: SCREW, TERMINAL BLOCK	10	2
3	312905	COVER, TERMINAL	10	2
4	N 313561	SCREW----NA Note: SCREW, TERMINAL COVER	10	8
5	312209	SCREW, #10-24 X 3/4 INCH Note: SCREW, TERMINAL BRACKET	10	4
6	312184	STRAP, GROUND Note: STRAP, GROUNDING	10	2
7	33001244	BLOCK, TERMINAL	10	2
8	312904	BRACKET, TERMINAL BLOCK Note: BRACKET, TERMINAL BLOCK	10	2
9	311270	WASHER, TERMINAL BLOCK	10	4
9	311093	WASHER, 7/32 INCH Note: WASHER, BRASS	10	6
10	311484	NUT, TERMINAL BLOCK	10	9
11	N 305535	CONTROL SHROUD-WHITE Note: SHROUD, CONTROL (WHT)	10	1
12	N 314943	COVER PLATE Note: PLATE, TOP COVER	10	2
13	N 33001608	COVER, TOP (WHT)	10	1
14	303846	SCREW & WASHER ASSY. Note: SCREW & WASHER ASSEMBLY	10	1
15	N 33001300	CABINET, STACK (LOWER-WHT) Note: (LWR-WHT)	10	1
15	N 33001298	CABINET, STACK (UPPER-WHT) COM Note: (UPR-WHT)	10	1
-	310632	SCREW Note: SCREW, CABINET	10	4
16	33001302	SPACER ASSY. (WHT) Note: (WHT)	10	1
17	310933	FASTENER Note: FASTENER, SPACER ASSEMBLY	10	4
18	302699	LEG, ADJUSTABLE (W/NUT)	10	4
19	210684	FOOT, RUBBER	10	4
20	210385	NUT, LOCK Note: NUT, ADJUSTABLE LEG	10	4
21	312951	COVER, ACCESS	10	2
22	N 313418	FILLER STRIP Note: STRIP, FILLER	10	1
23	311155	GROUND WIRE Note: GROUND WIRE	10	1
24	301548	CLAMP, GROUND (W/SCREW)	10	1
25	210587	SCREW Note: SCREW, SHROUD	10	5
26	313559	SCREW Note: SCREW, TOP COVER PLATE	10	2
27	213007	SCREW, CABINET	10	12
28	310632	SCREW Note: SCREW, SPACER ASSEMBLY	10	5
28	N 911052	SCREW Note: SCREW, SPACER ASSEMBLY	10	1
29	216423	SCREW Note: SCREW, ACCESS COVER	10	8
30	N 313561	SCREW----NA Note: SCREW, FILLER STRIP	10	1
30	310632	SCREW Note: SCREW, FILLER STRIP	10	2

*Color Code (-)=Not Shown #=Series, Serial Prefix or Run No., N=Not Available

Section: TUMBLER

Model: MDE13CSACW

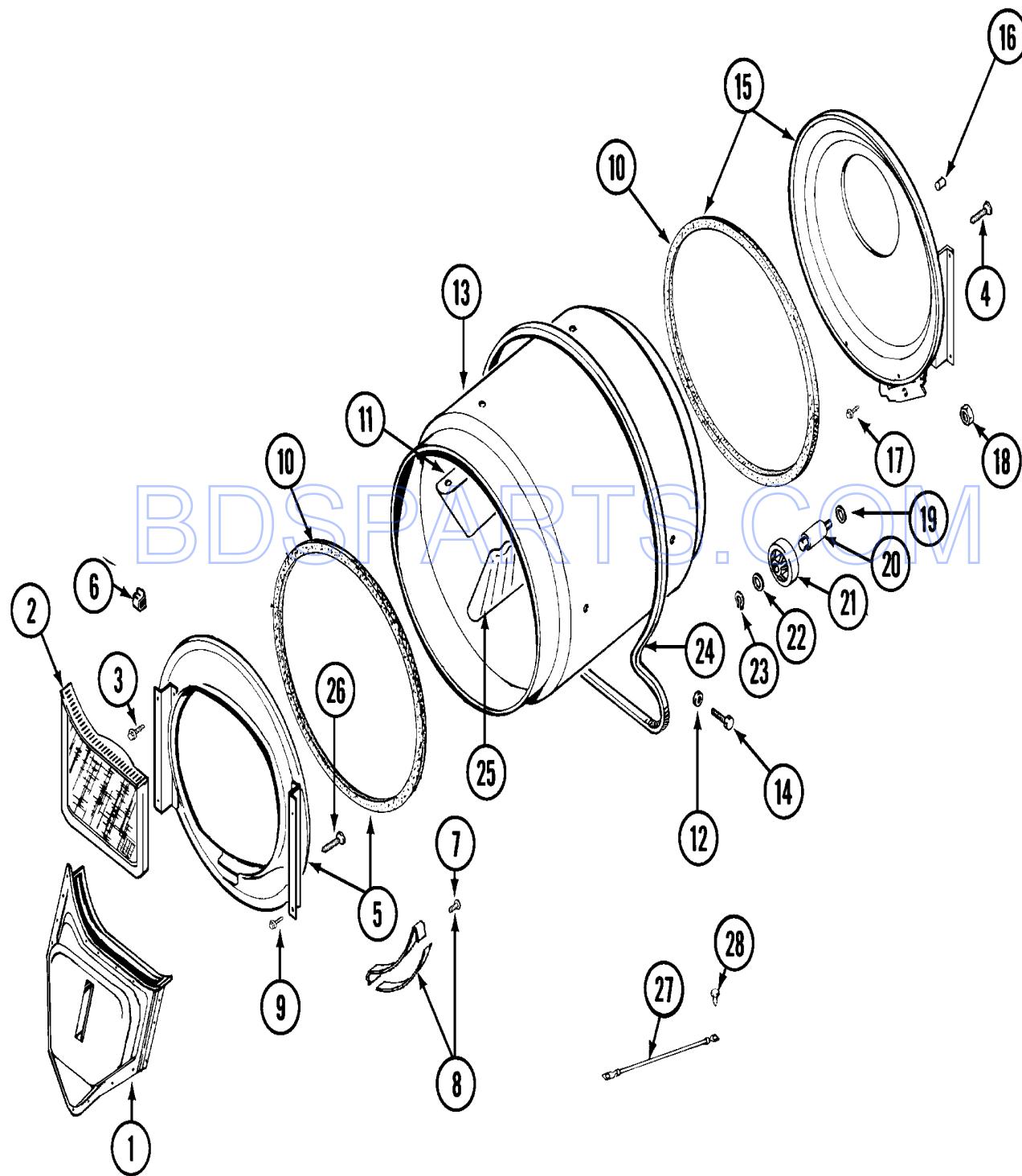

LD13-4

Section: TUMBLER

No.	Part No.	Description	Series	Qty
1	33001016	DUCT ASSY., OUTLET Note: OUTLET DUCT ASSEMBLY	10	2
2	33001170	FILTER, LINT	10	2
3	N 313764	SCREW Note: SCREW, TUMBLER SUPPORT	10	8
4	N 313561	SCREW----NA Note: SCREW, TUMBLER FRONT & BACK	10	4
5	33001179	FRONT, TUMBLER (W/SEAL)	10	2
6	310376	CLIP, WIRE HARNESS Note: CLIP, CABLE	10	2
7	210720	RIVET	10	8
8	306508	TUMBLER BEARING KIT Note: TUMBLER BEARING KIT	10	4
9	310632	SCREW Note: SCREW, TUMBLER FRONT	10	6
10	314820	SEAL, TUMBLER	10	4
11	33001012	BAFFLE (SHORT)	10	2
12	314158	WASHER Note: WASHER, BAFFLE	10	12
13	33001108	DRYER TUMBLER, W/O BAFFLES	10	2
14	310759	SCREW Note: SCREW, TUMBLER BAFFLE	10	12
15	33001178	BACK, TUMBLER (W/SEAL)	10	2
16	N 313915	COVER, THREAD	10	8
17	310632	SCREW Note: SCREW, TUMBLER BACK	10	6
18	312538	NUT, ROLLER SHAFT	10	4
19	313347	WASHER, SPRING (ROLLER SHAFT) Note: WASHER, SPRING	10	4
20	312948	SHAFT, TUMBLER ROLLER	10	4
21	303373	BEARING & ROLLER ASSEMBLY Note: ROLLER (W/BEARING)	10	4
22	312535	WASHER, ROLLER SHAFT	10	4
23	410233	RING, RETAINING	10	4
24	312959	BELT, TUMBLER & MOTOR Note: BELT, DRUM	10	2
25	33001004	BAFFLE, TALL Note: BAFFLE (TALL)	10	4
26	314110	SCREW, INLET DUCT Note: SCREW, OUTLET DUCT	10	8
27	901220	WIRE, GROUND Note: GROUND WIRE	10	2
28	910343	SCREW, GROUND WIRE	10	2

*Color Code (-)=Not Shown #=Series, Serial Prefix or Run No., N=Not Available

Section: HEATER

Model: MDE13CSACW

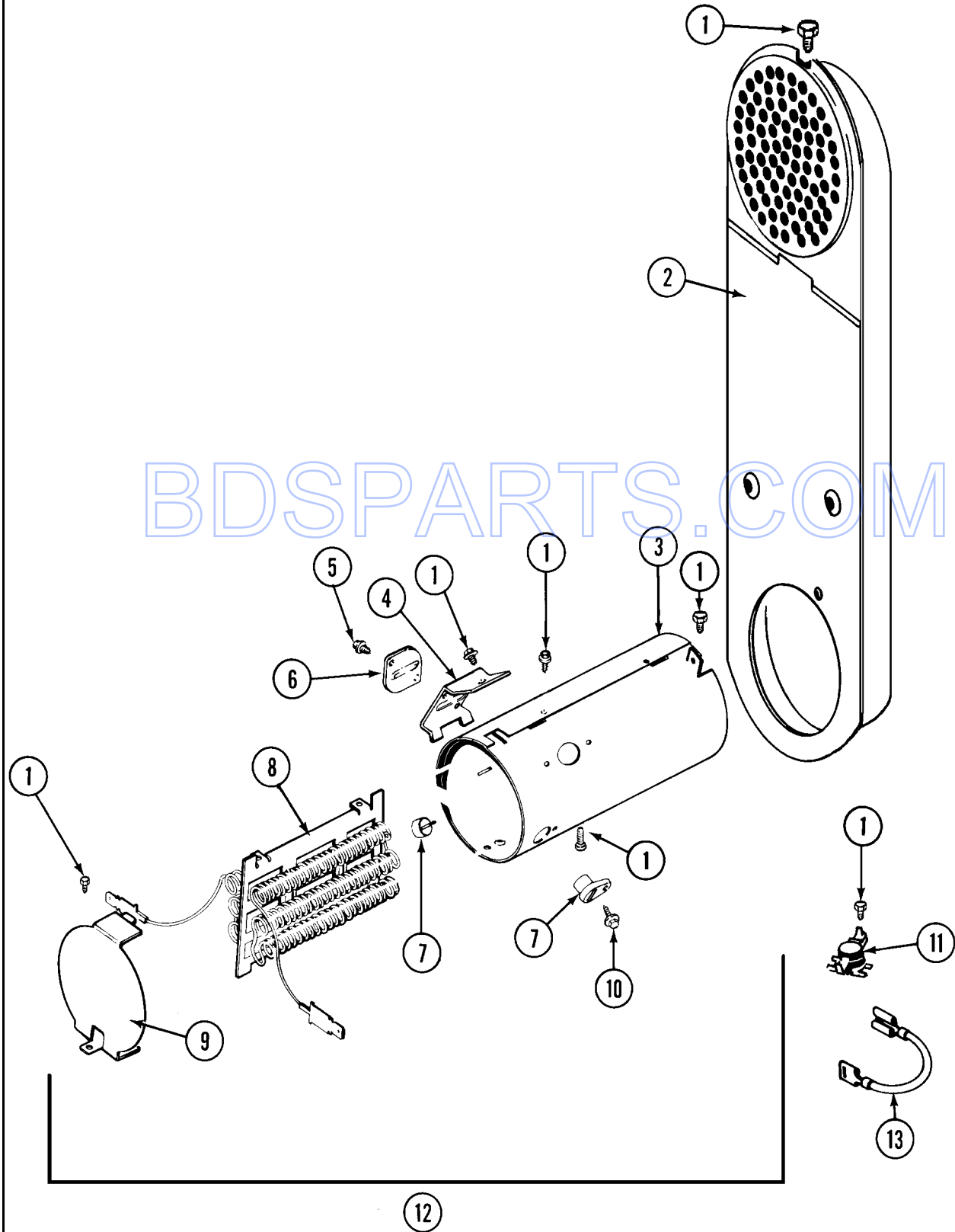

LD15-3

Section: HEATER

No.	Part No.	Description	Series	Qty
1	211294	SCREW Note: SCREW, HEATER	10	24
2	308503	INLET DUCT ASSY. Note: DUCT, INLET	10	2
3	314995	HEATER ENCLOSURE Note: ENCLOSURE, HEATER	10	2
4	315346	BRACKET, THERMAL FUSE	10	2
5	314848	SCREW Note: SCREW, THERMAL FUSE	10	4
6	307473	FUSE, THERMAL	10	2
7	314998	INSULATOR, TERMINAL	10	4
-	308613	HEATER SUB-ASSEMBLY (208V) Note: HEATER SUB-ASSEMBLY (208V)	10	2
8	308614	HEATER SUB-ASSEMBLY Note: HEATER SUB-ASSEMBLY (240V) (W/1,3,7 & 10)	10	2
9	314999	SHIELD, RADIANT	10	2
10 N	314554	SCREW Note: SCREW, TERMINAL INSULATOR	10	4
11	303396	THERMOSTAT, HI-LIMIT (ELEC)	10	2
12	307179	HEATER ASSEMBLY(COMPLETE 240V) Note: HEATER ASSEMBLY (COMPLETE)	10	2
13	307173	WIRE, JUMPER Note: JUMPER WIRE	10	2
-	308590	CONVERSION KIT (240V TO 208V) Note: CONVERSION KIT (240V TO 208V)	10	2

BDSPARTS.COM

*Color Code (-)=Not Shown #=Series, Serial Prefix or Run No., N=Not Available

Section: MOTOR DRIVE

Model: MDE13CSACW

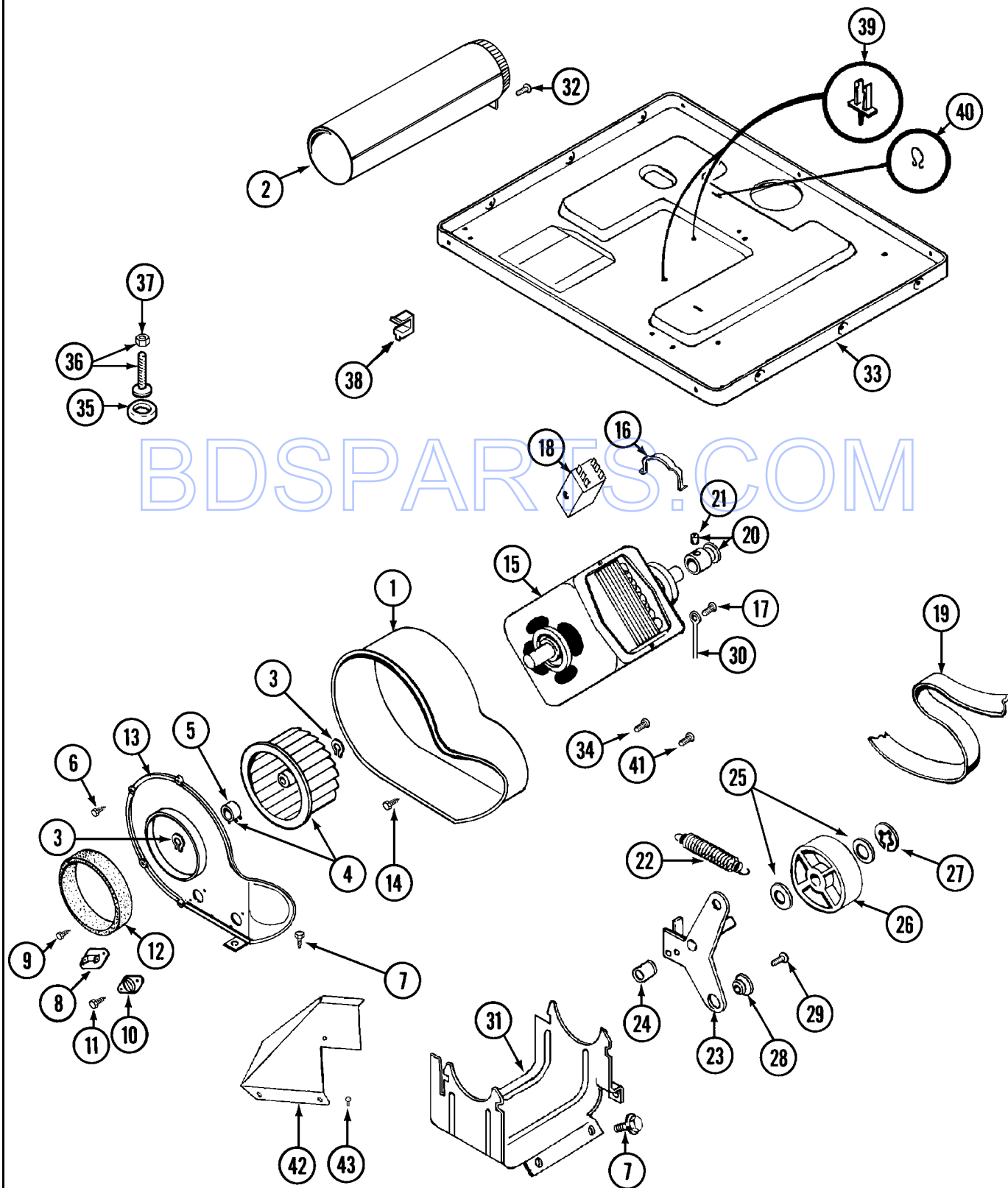

BDSPARES.COM

Section: MOTOR DRIVE

No.	Part No.	Description	Series	Qty
1	312893	HOUSING, BLOWER	10	2
2	303442	EXHAUST DUCT ASSY. Note: EXHAUST DUCT ASSEMBLY	10	2
3	410233	RING, RETAINING	10	4
4	303836	BLOWER WHEEL ASSEMBLY & CLAMP Note: BLOWER WHEEL ASSEMBLY	10	2
5	312967	CLAMP, BLOWER HOUSING	10	2
6	312961	SCREW Note: SCREW, HOUSING COVER	10	12
7	N 313561	SCREW----NA Note: SCREW, HOUSING COVER	10	6
8	306967	THERMOSTAT, MULTI-TEMP Note: THERMOSTAT, CYCLING (155 DEG)	10	2
8	303392	CYCLING THERMOSTAT 140 DEG. Note: THERMOSTAT, CYCLING (140 DEG)	10	2
8	303225	THERMOSTAT, PERMANENT PRESS Note: THERMOSTAT, PERMANENT PRESS	10	2
-	33001306	HARNES, WIRE Note: JUMPER WIRE, THERMOSTAT	10	2
9	211294	SCREW Note: SCREW, THERMOSTATS	10	8
10	306604	CUT-OFF, THERMAL Note: THERMAL CUT-OFF	10	2
11	314848	SCREW Note: SCREW, THERMAL CUT-OFF	10	4
12	312901	SEAL, BLOWER Note: SEAL, HOUSING COVER	10	2
13	314847	COVER, BLOWER HOUSING	10	2
14	314818	SCREW Note: SCREW, BLOWER HOUSING	10	8
15	303358	MOTOR	10	2
16	015825	CLIP, MOTOR	10	4
17	910343	SCREW, GROUND WIRE	10	2
18	N 306207	SWITCH, MOTOR START-PROD. Note: SWITCH, MOTOR EXTERNAL START (PROD. # 303358-8 & 303358-9)	10	2
18	303877	SWITCH, MOTOR Note: SWITCH, MOTOR EXTERNAL START (PROD. # 303358-2, 303358-4 & 303358-7)	10	2
18	303879	SWITCH, MOTOR STARTPROD. Note: SWITCH, MOTOR EXTERNAL START (PROD. # 303358 & 303358-6)	10	2
19	312959	BELT, TUMBLER & MOTOR	10	2
20	305185	PULLEY, MOTOR (W/SET SCREW)	10	2
21	053241	SET SCREW, PULLEY	10	2
22	303945	IDLER SPRING ASSEMBLY Note: IDLER SPRING ASSEMBLY	10	2
23	303363	IDLER ARM & SHAFT ASSY. Note: IDLER ARM & SHAFT ASSEMBLY	10	2
24	313582	SPACER, IDLER BRACKET	10	2
25	312527	WASHER, IDLER SHAFT (QTY-1)	10	4
26	303705	PULLEY, IDLER	10	2
27	312958	RETAINING RING, IDLER SHAFT Note: RING, RETAINING	10	2
28	N 312894	SLEEVE, IDLER ARM	10	2
29	014874	SCREW Note: SCREW, IDLER ARM	10	2
30	901220	WIRE, GROUND Note: GROUND WIRE	10	2
31	N 312897	SUPPORT, MOTOR	10	2
32	310632	SCREW Note: SCREW, EXHAUST DUCT	10	2
33	307482	BASE ASSY Note: (UPR)	10	1
33	306530	BASE WELD ASSEMBLY Note: BASE ASSEMBLY (LWR)	10	1
34	211294	SCREW Note: SCREW, GROUND WIRE	10	2
35	210684	FOOT, RUBBER	10	4
36	302699	LEG, ADJUSTABLE (W/NUT)	10	4
37	210385	NUT, LOCK Note: NUT, ADJUSTABLE LEG	10	4
38	310376	CLIP, WIRE HARNESS Note: CLIP, CABLE	10	2
39	315471	RETAINER, WIRE Note: RETAINER, WIRE HARNESS	10	6
40	410490	SPRING, WIRE HARNESS	10	4
41	312961	SCREW Note: SCREW, SPACER	10	2
42	315122	COVER, THERMOSTAT	10	2
43	310632	SCREW Note: SCREW, THERMOSTAT COVER	10	4

*Color Code (-)=Not Shown #=Series, Serial Prefix or Run No., N=Not Available

Section: WIRING INFORMATION

Model: MDE13CSACW

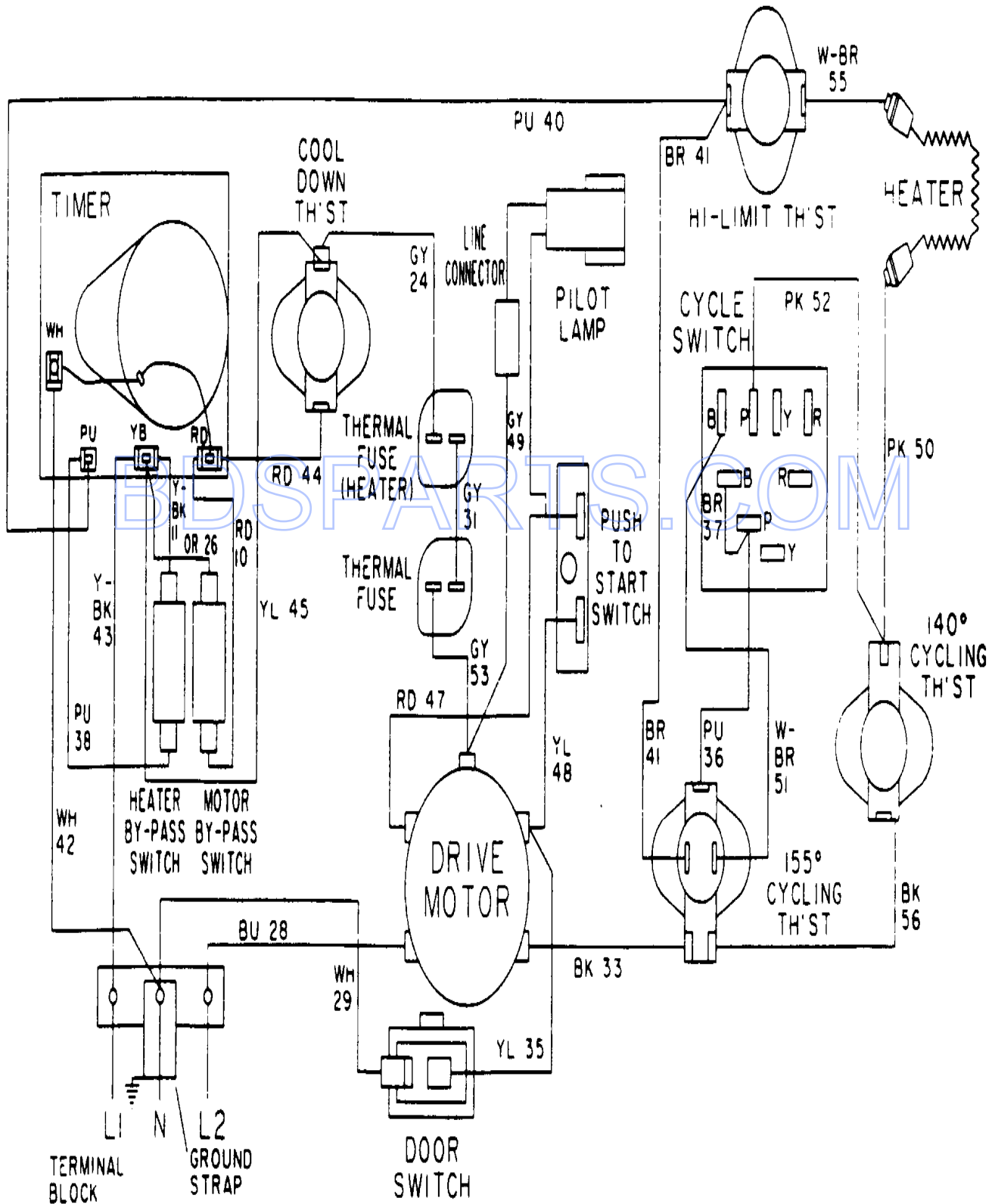

15001319

