

# DRYER

## Repair Parts List

MODEL NUMBER

MDE13PDBCW

DDSPARTS.COM

When requesting service or ordering parts, always provide the following information:

- Product Type
- Part Number
- Model Number
- Part Description

**MAYTAG**®

©2005 Maytag Services

Section: CONTROLS & UPPER PANEL

Model: MDE13PDBCW

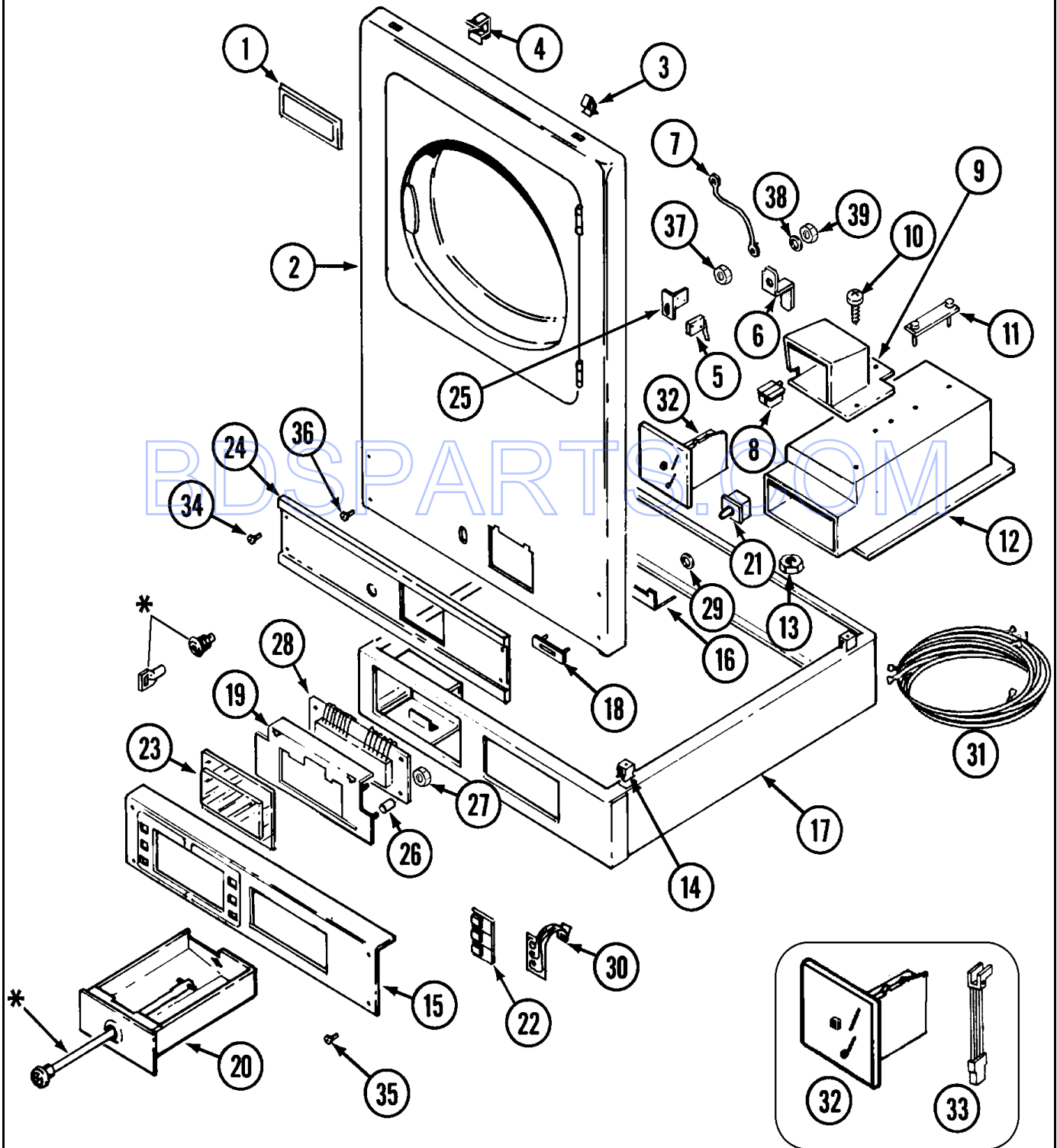

\*Contact Your Commercial Distributor for Locks & Keys

## Section: CONTROLS & UPPER PANEL

No.	Part No.	Description	Series	Qty
1	33001711	NAMEPLATE	10	1
-	33001486	PANEL, FASTENER	10	4
2	33001447	PANEL, UPPER FRONT (WHT) Note: (UPR-WHT)	10	1
3	212982	FASTENER, PANEL Note: SPRING, FASTENER	10	2
4	310376	CLIP, WIRE HARNESS Note: CLIP, FASTENER	10	2
-	912012	SCREW Note: SCREW, SWITCH	10	2
5	306232	ACCESS SWITCH Note: SWITCH, ACCESS	10	1
6	314625	LOCKING CAM Note: CAM, LOCKING	10	1
7	306712	GROUND WIRE Note: GROUND WIRE, LOCK	10	1
8	314635	COIN CHUTE Note: CHUTE, COIN	10	1
9	N 306367	COIN DROP ASSEMBLY----NA Note: COVER, COIN DROP	10	1
10	314654	CARRIAGE BOLT Note: BOLT, COIN DROP COVER	10	2
11	22001810	STRAP, MOUNTING	10	1
-	N 212672	WASHER Note: LOCKWASHER, MOUNTING STRAP	10	2
-	910387	LOCK WASHER Note: LOCKWASHER, VAULT ASSEMBLY	10	1
12	N 308141	VAULT ASSY WHT Note: VAULT ASSEMBLY (WHT)	10	1
13	052740	NUT Note: NUT, MOUNTING STRAP COVER	10	4
-	N 212672	WASHER Note: WASHER, COVER BOLT	10	2
14	310933	FASTENER Note: CLIP, SUPPORT ASSEMBLY	10	4
15	N 33001712	EXTRUSION, CONTROL (LWR) Note: CONTROL, EXTRUSION (LWR)	10	1
-	310632	SCREW Note: SCREW, BRACKET	10	1
16	314631	BRACKET - Note: BRACKET, COIN DROP	10	1
-	N 313561	SCREW----NA Note: SCREW, BRACKET	10	1
17	N 33001233	SUPPORT (WHT) Note: SUPPORT ASSEMBLY (WHT)	10	1
18	306233	COIN ACCEPTOR STRAP Note: STRAP, COIN ACCEPTOR	10	1
-	910186	SCREW Note: SCREW, PLATE	10	3
19	33001201	PLATE, CONTROL MOUNTING Note: PLATE, CONTROL MOUNTING	10	1
20	308143	COIN TRAY - WHT Note: TRAY, COIN (WHT)	10	1
21	33001250	SWITCH, SENSOR Note: SWITCH, VAULT & SERVICE DOOR	10	1
22	33001156	BUTTON Note: BUTTON, PUSH	10	2
23	33001209	COVER, DISPLAY (LOWER) Note: COVER, DISPLAY	10	1
24	N 33001713	EXTRUSION, CONTROL (UPR) Note: CONTROL, EXTRUSION (UPR)	10	1
25	314634	ACCESS SWITCH BRACKET Note: BRACKET, ACCESS SWITCH	10	1
26	33001204	STANDOFF, CIRCUIT BOARD Note: STAND-OFF, CONTROL BOARD	10	4
27	912077	LOCKNUT Note: NUT, CONTROL BOARD	10	4
28	33001747	BOARD ASSY., CONTROL Note: CIRCUIT BOARD ASSEMBLY	10	1
29	052659	HEX. NUT, #8-32 Note: NUT, COIN DROP	10	2
30	33001200	SWITCH, MEMBRANE Note: -	10	2
-	314522	STRAIN RELIEF Note: GROMMET, STRAIN RELIEF	10	1
31	33001409	WIRE HARNESS, MAIN (LOWER) Note: (LWR)	10	1
31	33001408	WIRE HARNESS, MAIN (UPPER) Note: WIRE HARNESS, MAIN (UPR)	10	1
-	910768	CABLE STRAP-HARNESS TO BASE Note: STRAP, HARNESS	10	1
32	308121	REJECTOR ASSY 25CENTS Note: REJECTOR ASSEMBLY (25 CENTS)	10	1
33	33001025	SWITCH ASSY., OPTIC Note: OPTIC SWITCH ASSEMBLY	10	1
-	315427	SCREW Note: SCREW, SWITCH ASSEMBLY	10	1
34	315489	SCREW, TORX (LONG) Note: SCREW, FRONT PANEL	10	3
34	215506	SCREW, TORX Note: SCREW, SWITCH ASSEMBLY	10	2
35	215506	SCREW, TORX Note: SCREW, EXTRUSION (LWR)	10	4
36	314666	SCREW Note: SCREW, PANEL (UPR)	10	2
-	N 314653	RETAINER FOR FRONT PANEL Note: CLIP, CABINET SCREW	10	2
37	212328	NUT, HEX Note: NUT, LOCK	10	1
38	22001354	WASHER, LOCK Note: WASHER, LOCK	10	1
39	22001355	NUT Note: NUT, LOCK	10	1

\*Color Code (-)=Not Shown #=Series, Serial Prefix or Run No., N=Not Available

Section: FRONT

Model: MDE13PDBCW

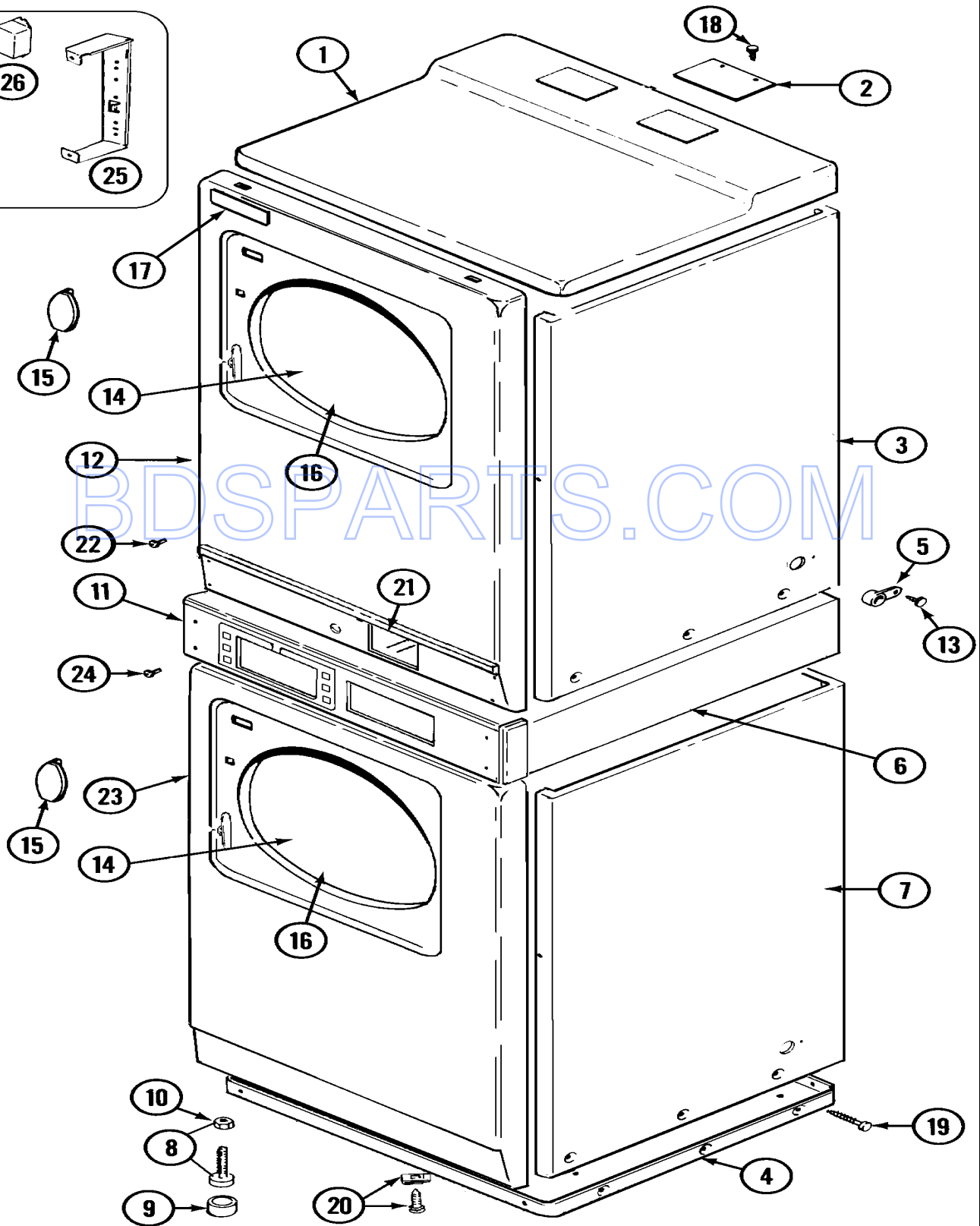
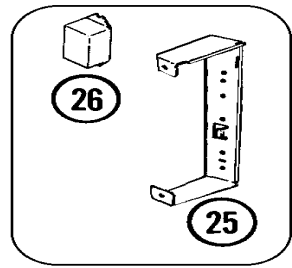

CD13-4

## Section: FRONT

No.	Part No.	Description	Series	Qty
1	N 33001608	COVER, TOP (WHT)	10	1
2	N 314943	COVER PLATE Note: PLATE, COVER	10	2
3	N 33001329	CABINET (WHT) Note: CABINET (UPR-WHT)	10	1
4	306530	BASE WELD ASSEMBLY Note: (LWR)	10	1
4	306261	BASE ASSEMBLY Note: BASE ASSEMBLY (UPR)	10	1
5	910768	CABLE STRAP-HARNESS TO BASE Note: STOP, CABLE	10	2
-	911050	SCREW	10	1
6	N 33001233	SUPPORT (WHT) Note: SUPPORT ASSEMBLY (WHT)	10	1
-	310933	FASTENER	10	4
-	314663	SCREW	10	2
-	310632	SCREW	10	5
7	N 33001327	CABINET (WHT) Note: CABINET (LWR-WHT)	10	1
8	302699	LEG, ADJUSTABLE (W/NUT)	10	4
9	210684	FOOT, RUBBER	10	4
10	210385	NUT, LOCK	10	4
11	N 33001712	EXTRUSION, CONTROL (LWR)	10	1
-	33001486	PANEL, FASTENER	10	4
12	33001447	PANEL, UPPER FRONT (WHT) Note: (UPR-WHT)	10	1
-	314666	SCREW Note: SCREW, PANEL (UPR)	10	2
-	N 314653	RETAINER FOR FRONT PANEL Note: CLIP, CABINET SCREW	10	2
13	211168	SCREW, #8 X 5/16 INCH Note: SCREW, CABLE STOP	10	2
14	33001203	PANEL, INNER (W/SEAL) Note: PANEL, CLEAR INNER (W/SEAL)	10	2
15	314939	HANDLE Note: HANDLE, DOOR (WHT)	10	2
16	314967	DOOR W/WIN CUT OUT OUTER WHT Note: PANEL, OUTER DOOR (WHT)	10	1
17	33001711	NAMEPLATE	10	1
18	313559	SCREW Note: SCREW, COVER PLATE	10	2
19	213007	SCREW, CABINET Note: SCREW, CABINET SIDES	10	12
20	22001496	SCREW, TORX Note: SCREW, FRONT PANEL	10	4
21	N 33001713	EXTRUSION, CONTROL (UPR)	10	1
22	215506	SCREW, TORX Note: SCREW, EXTRUSION	10	2
22	315489	SCREW, TORX (LONG) Note: SCREW, EXTRUSION & FRONT	10	3
-	33001486	PANEL, FASTENER	10	4
-	33001614	PLUG, FRONT PANEL (WHT)	10	1
23	N 33001714	PANEL, FRONT (LWR-WHT)	10	1
24	215506	SCREW, TORX Note: SCREW, EXTRUSION	10	4
25	314627	RELAY BRACKET Note: BRACKET, RELAY	10	1
-	310632	SCREW Note: SCREW, BRACKET	10	2
26	206824	RELAY, SPST 24VDC Note: RELAY, MOTOR (24V DC)	10	2
26	306398	RELAY - SPST HEATER Note: RELAY, HEATER	10	2
-	251119	SCREW Note: SCREW, RELAYS	10	2

\*Color Code (-)=Not Shown #=Series, Serial Prefix or Run No., N=Not Available

Section: DOOR

Model: MDE13PDBCW

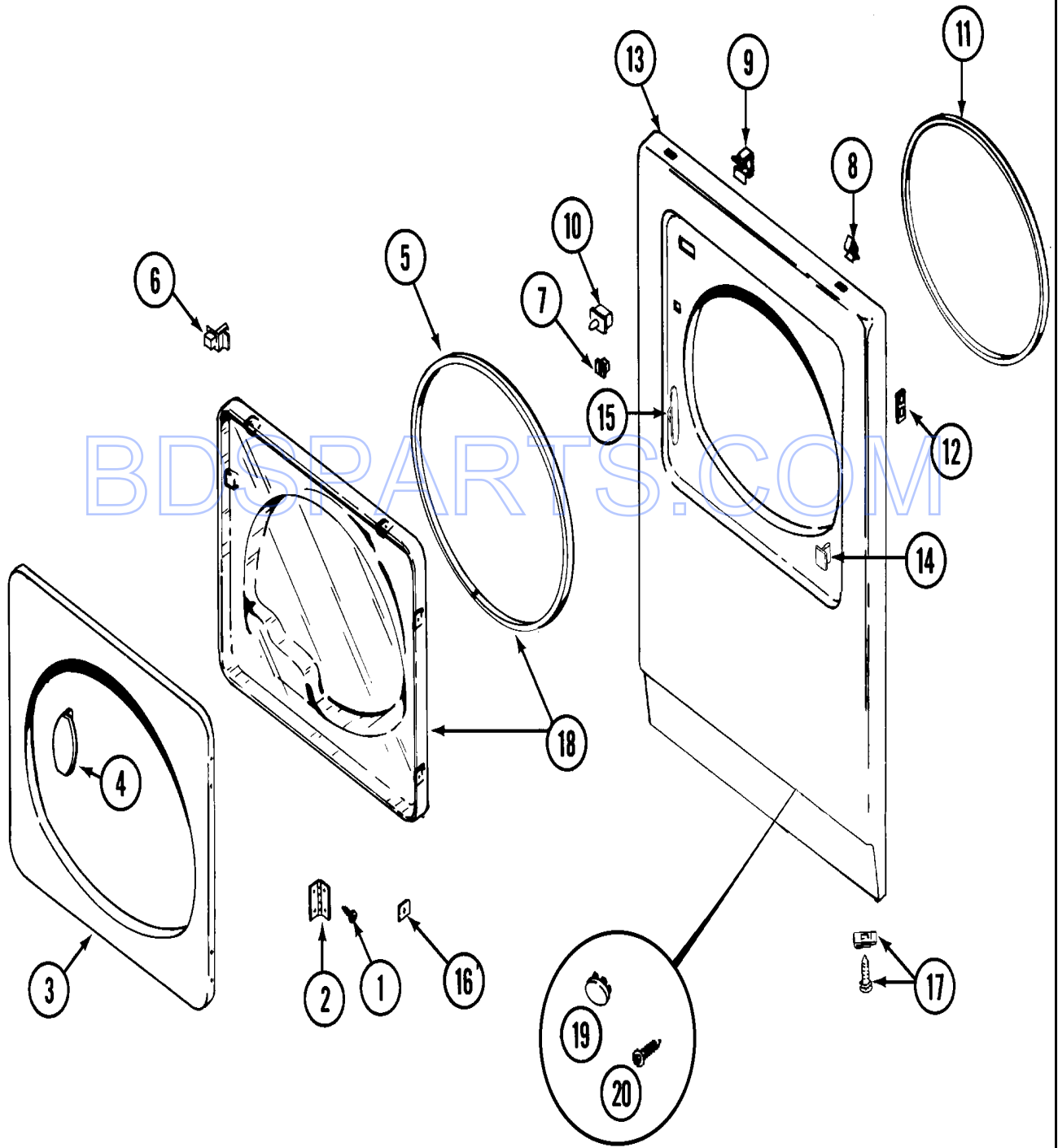

CD12-3

## Section: DOOR

No.	Part No.	Description	Series	Qty
1	314062	SCREW Note: SCREW	10	28
2	33001230	HINGE, DOOR	10	4
3	314967	DOOR W/WIN CUT OUT OUTER WHT Note: PANEL, OUTER DOOR (WHT)	10	1
4	314939	HANDLE Note: HANDLE, DOOR (WHT)	10	1
5	33001192	SEAL, DOOR	10	2
6	33001305	STRIKE, DOOR (W/BRACKET)	10	2
7	304578	CATCH, DOOR (FEMALE)	10	2
8	212982	FASTENER, PANEL Note: FASTENER, SPRING	10	4
9	310376	CLIP, WIRE HARNESS Note: CLIP, CABLE	10	6
10	33001420	SWITCH, DOOR	10	2
11	314937	SEAL, FRONT PANEL	10	2
12	N 33001173	NUT, SPEED Note: CLIP, HINGE SCREW	10	4
-	N 33001172	SCREW, PLASTIC Note: FASTENER, FRONT PANEL	10	4
13	N 33001714	PANEL, FRONT (LWR-WHT)	10	1
13	33001447	PANEL, UPPER FRONT (WHT) Note: (UPR-WHT)	10	1
-	33001486	PANEL, FASTENER	10	8
14	N 33001174	PLUG, DOOR CATCH	10	1
15	33001175	COVER, HINGE HOLE (WHT)	10	2
16	313910	CLIP, DOOR LINER TO OUTER PNL Note: CLIP, INNER DOOR SCREW	10	18
17	22001496	SCREW, TORX Note: SCREW, FRONT PANEL	10	2
18	33001203	PANEL, INNER (W/SEAL) Note: PANEL, CLEAR INNER (W/SEAL)	10	2
19	33001614	PLUG, FRONT PANEL (WHT)	10	1
20	315489	SCREW, TORX (LONG) Note: SCREW, SIGHT HOLE	10	1

\*Color Code (-)=Not Shown #=Series, Serial Prefix or Run No., N=Not Available

Section: REAR

Model: MDE13PDBCW

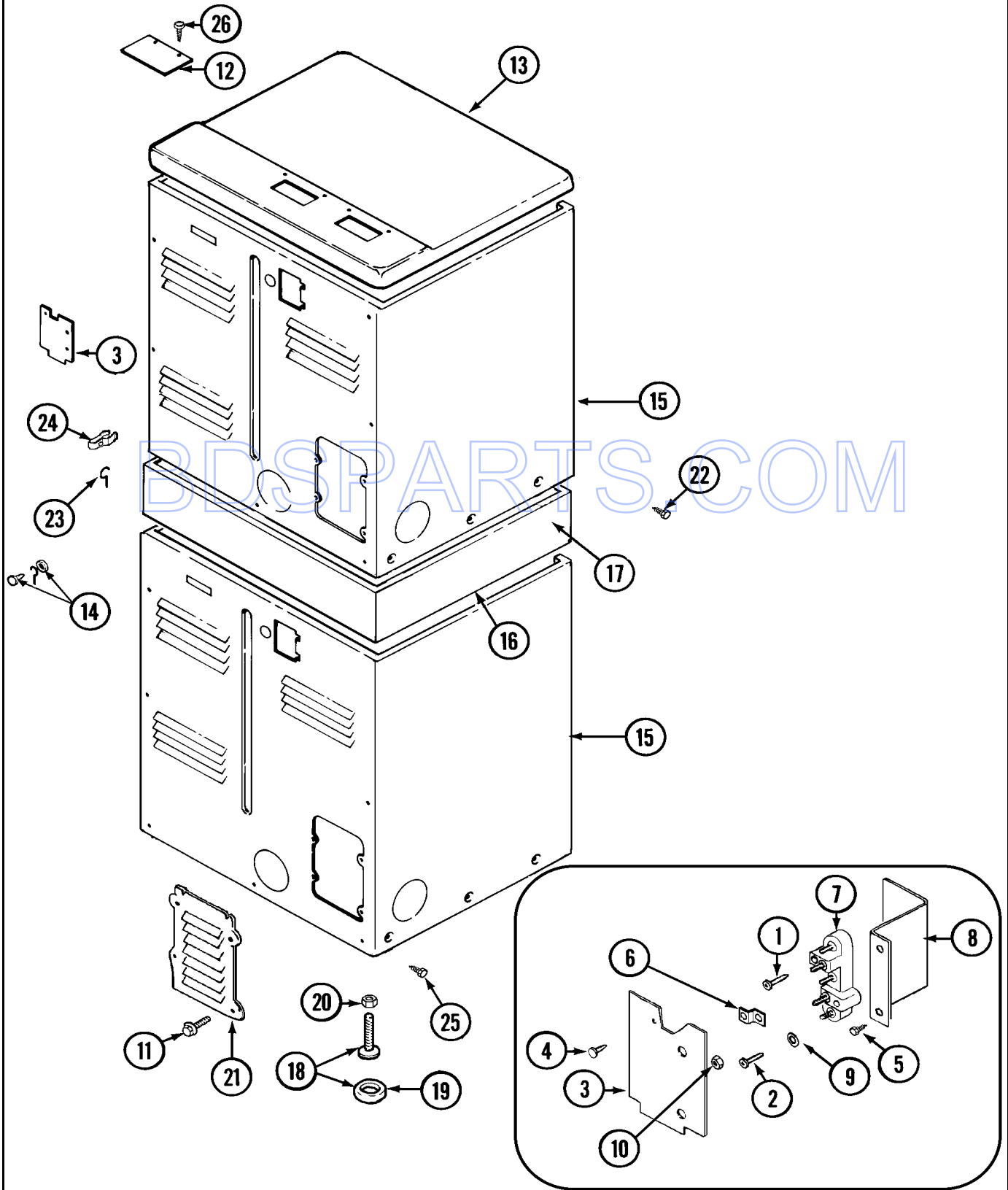

CD18-17



## Section: REAR

No.	Part No.	Description	Series	Qty
1	N 33001245	SCREW----NA Note: SCREW, GROUND STRAP	10	2
2	310632	SCREW Note: SCREW, TERMINAL BLOCK	10	2
3	312905	COVER, TERMINAL	10	2
4	N 313561	SCREW----NA Note: SCREW, TERMINAL COVER	10	8
5	312209	SCREW, #10-24 X 3/4 INCH Note: SCREW, TERMINAL BRACKET	10	4
6	312184	STRAP, GROUND Note: STRAP, GROUNDING	10	2
7	33001244	BLOCK, TERMINAL	10	1
8	312904	BRACKET, TERMINAL BLOCK Note: BRACKET, TERMINAL	10	2
9	311270	WASHER, TERMINAL BLOCK Note: WASHER, TERMINAL BLOCK	10	6
9	311093	WASHER, 7/32 INCH Note: WASHER, BRASS	10	2
10	311484	NUT, TERMINAL BLOCK	10	6
11	216423	SCREW Note: SCREW, ACCESS COVER	10	8
12	N 314943	COVER PLATE Note: PLATE, TOP COVER	10	2
13	N 33001608	COVER, TOP (WHT)	10	1
14	303846	SCREW & WASHER ASSY. Note: SCREW & WASHER ASSEMBLY	10	1
15	N 33001327	CABINET (WHT) Note: CABINET (LWR-WHT)	10	1
-	310632	SCREW Note: SCREW, CABINET	10	4
15	N 33001329	CABINET (WHT) Note: CABINET (UPR-WHT)	10	1
16	N 33001233	SUPPORT (WHT) Note: SUPPORT ASSEMBLY (WHT)	10	1
17	310933	FASTENER Note: FASTENER, SPACER ASSEMBLY	10	2
18	302699	LEG, ADJUSTABLE (W/NUT)	10	4
19	210684	FOOT, RUBBER	10	4
20	210385	NUT, LOCK Note: NUT, ADJUSTABLE LEG	10	4
21	312951	COVER, ACCESS	10	2
22	310632	SCREW Note: SCREW, SUPPORT	10	5
22	N 911052	SCREW Note: SCREW, SUPPORT	10	1
23	311155	GROUND WIRE Note: GROUND WIRE	10	1
24	301548	CLAMP, GROUND (W/SCREW) Note: CLAMP, GROUND (W/SCREW)	10	1
-	313122	SCREW - BAFFLE TO TUMBLER Note: SCREW, CLAMP	10	1
25	213007	SCREW, CABINET Note: SCREW, CABINET SIDES	10	12
26	313559	SCREW Note: SCREW, TOP COVER PLATE	10	2

\*Color Code (-)=Not Shown #=Series, Serial Prefix or Run No., N=Not Available

Section: TUMBLER

Model: MDE13PDBCW

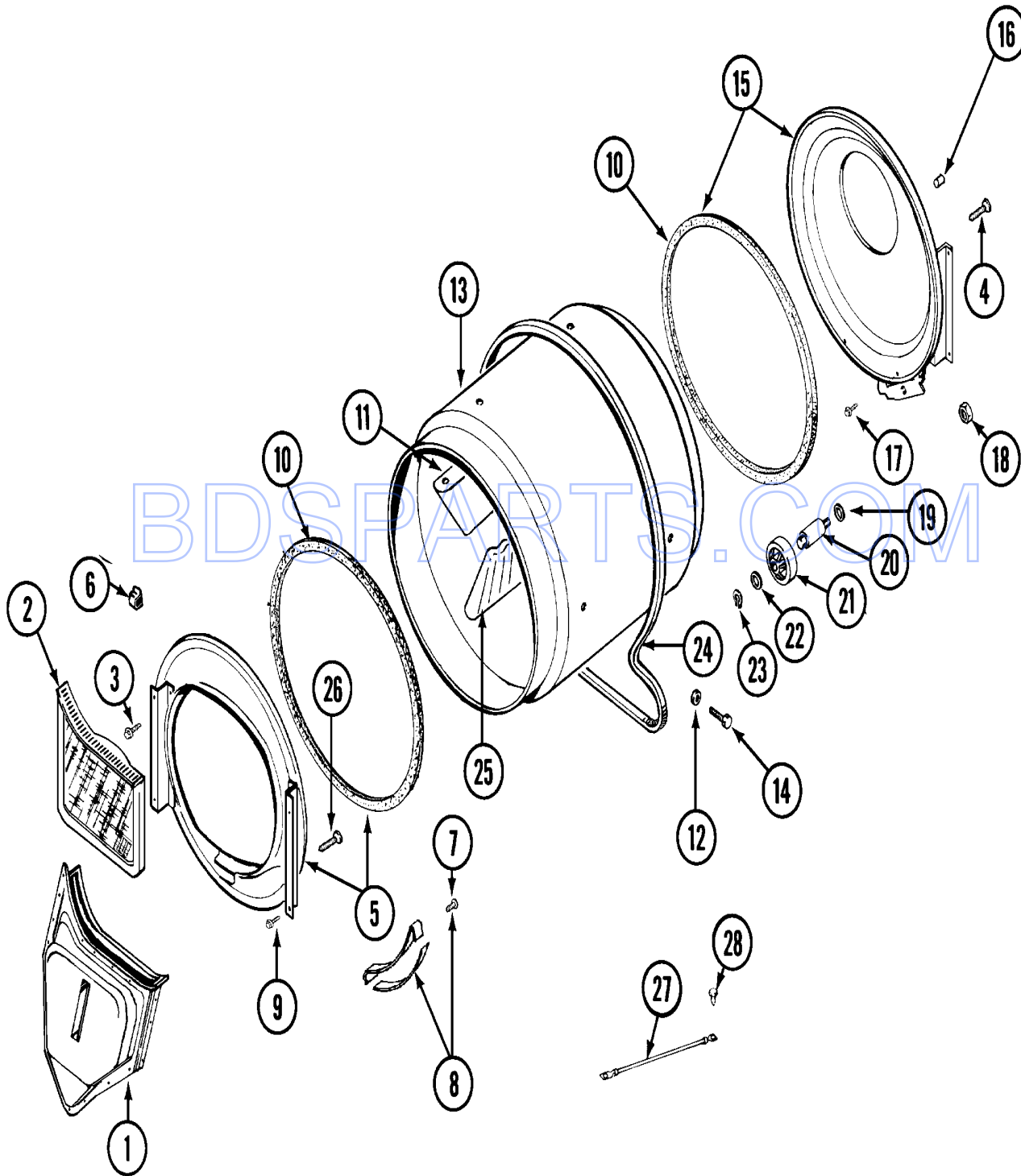

## Section: TUMBLER

No.	Part No.	Description	Series	Qty
1	33001016	DUCT ASSY., OUTLET Note: OUTLET DUCT ASSEMBLY	10	1
2	33001170	FILTER, LINT	10	2
3	N 313764	SCREW Note: SCREW, TUMBLER SUPPORT	10	8
4	N 313561	SCREW----NA Note: SCREW, TUMBLER FRONT & BACK	10	4
5	33001179	FRONT, TUMBLER (W/SEAL) Note: FRONT, TUMBLER (W/SEAL)	10	2
6	310376	CLIP, WIRE HARNESS Note: CLIP, CABLE	10	2
7	210720	RIVET	10	8
8	306508	TUMBLER BEARING KIT Note: TUMBLER BEARING KIT	10	4
9	310632	SCREW Note: SCREW, TUMBLER FRONT	10	6
10	314820	SEAL, TUMBLER	10	4
11	33001012	BAFFLE (SHORT)	10	2
12	314158	WASHER Note: WASHER, BAFFLE SCREW	10	12
13	33001108	DRYER TUMBLER, W/O BAFFLES	10	2
14	310759	SCREW Note: SCREW, TUMBLER BAFFLE	10	12
15	33001178	BACK, TUMBLER (W/SEAL)	10	2
16	N 313915	COVER, THREAD	10	8
17	310632	SCREW Note: SCREW, TUMBLER BACK	10	6
18	312538	NUT, ROLLER SHAFT	10	4
19	313347	WASHER, SPRING (ROLLER SHAFT) Note: WASHER, SPRING	10	4
20	312948	SHAFT, TUMBLER ROLLER	10	4
21	303373	BEARING & ROLLER ASSEMBLY Note: ROLLER (W/BEARING)	10	4
22	312535	WASHER, ROLLER SHAFT	10	4
23	410233	RING, RETAINING Note: RING, RETAINING	10	4
24	312959	BELT, TUMBLER & MOTOR Note: BELT, TUMBLER	10	2
25	33001004	BAFFLE, TALL Note: BAFFLE (TALL)	10	4
26	314110	SCREW, INLET DUCT Note: SCREW, OUTLET DUCT	10	8
27	901220	WIRE, GROUND Note: GROUND WIRE	10	2
28	910343	SCREW, GROUND WIRE	10	2

\*Color Code (-)=Not Shown #=Series, Serial Prefix or Run No., N=Not Available

Section: HEATER

Model: MDE13PDBCW

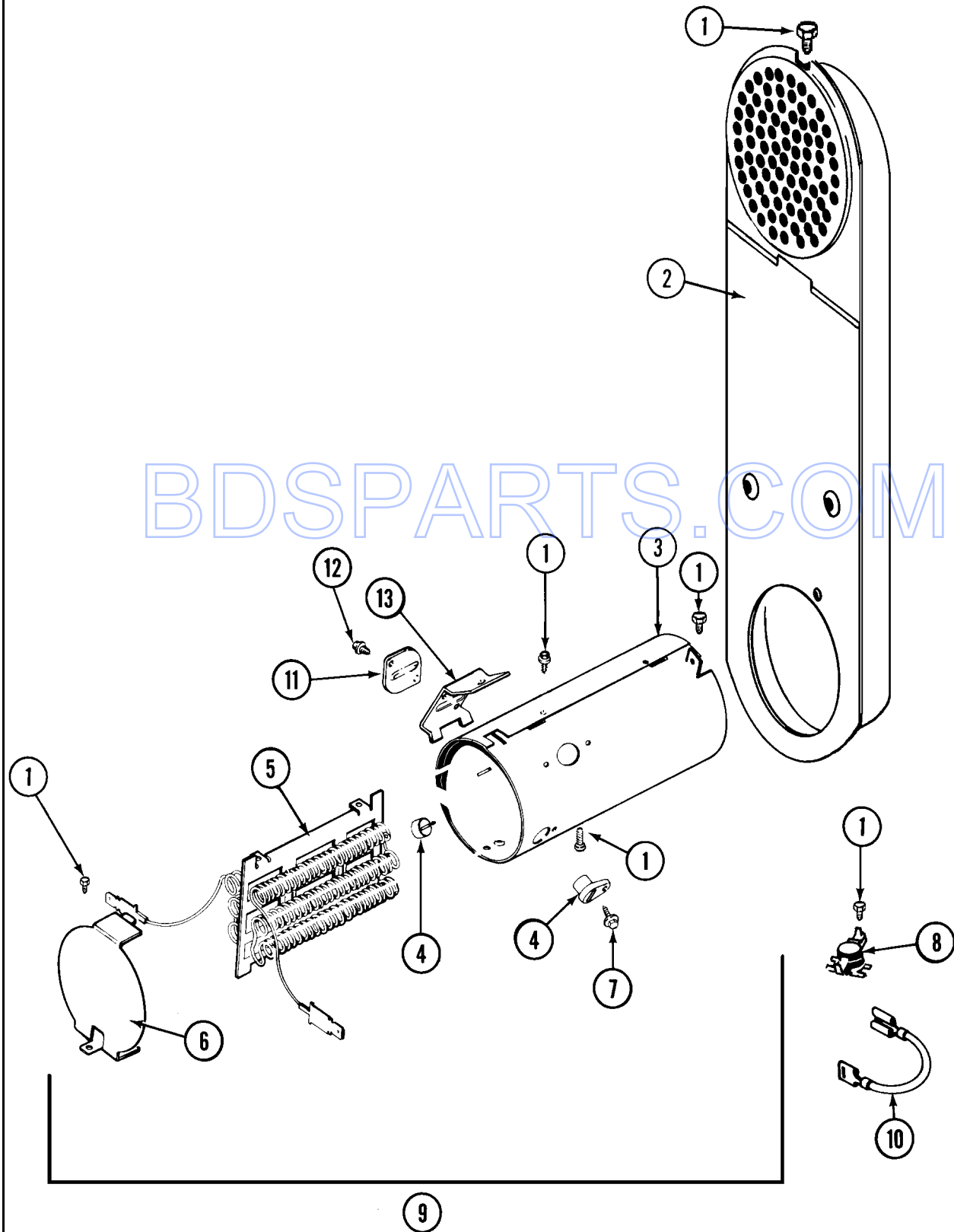

CD15-2

**Section: HEATER**

No.	Part No.	Description	Series	Qty
1	211294	SCREW Note: SCREW, DUCT	10	24
2	308503	INLET DUCT ASSY. Note: INLET DUCT ASSEMBLY	10	2
3	314995	HEATER ENCLOSURE Note: ENCLOSURE, HEATER	10	2
4	314998	INSULATOR, TERMINAL	10	4
5	308614	HEATER SUB-ASSEMBLY Note: HEATER SUB-ASSEMBLY (240V) (W/ 1, 3, 4, & 7)	10	2
6	314999	SHIELD, RADIANT	10	2
7	N 314554	SCREW Note: SCREW, TERMINAL INSULATOR	10	4
8	303396	THERMOSTAT, HI-LIMIT (ELEC)	10	2
9	307179	HEATER ASSEMBLY(COMPLETE 240V) Note: HEATER ASSEMBLY (240V)	10	2
10	307173	WIRE, JUMPER	10	2
11	307473	FUSE, THERMAL	10	2
12	314848	SCREW	10	2
13	315346	BRACKET, THERMAL FUSE	10	2
-	308590	CONVERSION KIT (240V TO 208V) Note: CONVERSION KIT (240V TO 208V)	10	2

BDSPARTS.COM

\*Color Code (-)=Not Shown #=Series, Serial Prefix or Run No., N=Not Available

Section: MOTOR DRIVE

Model: MDE13PDBCW

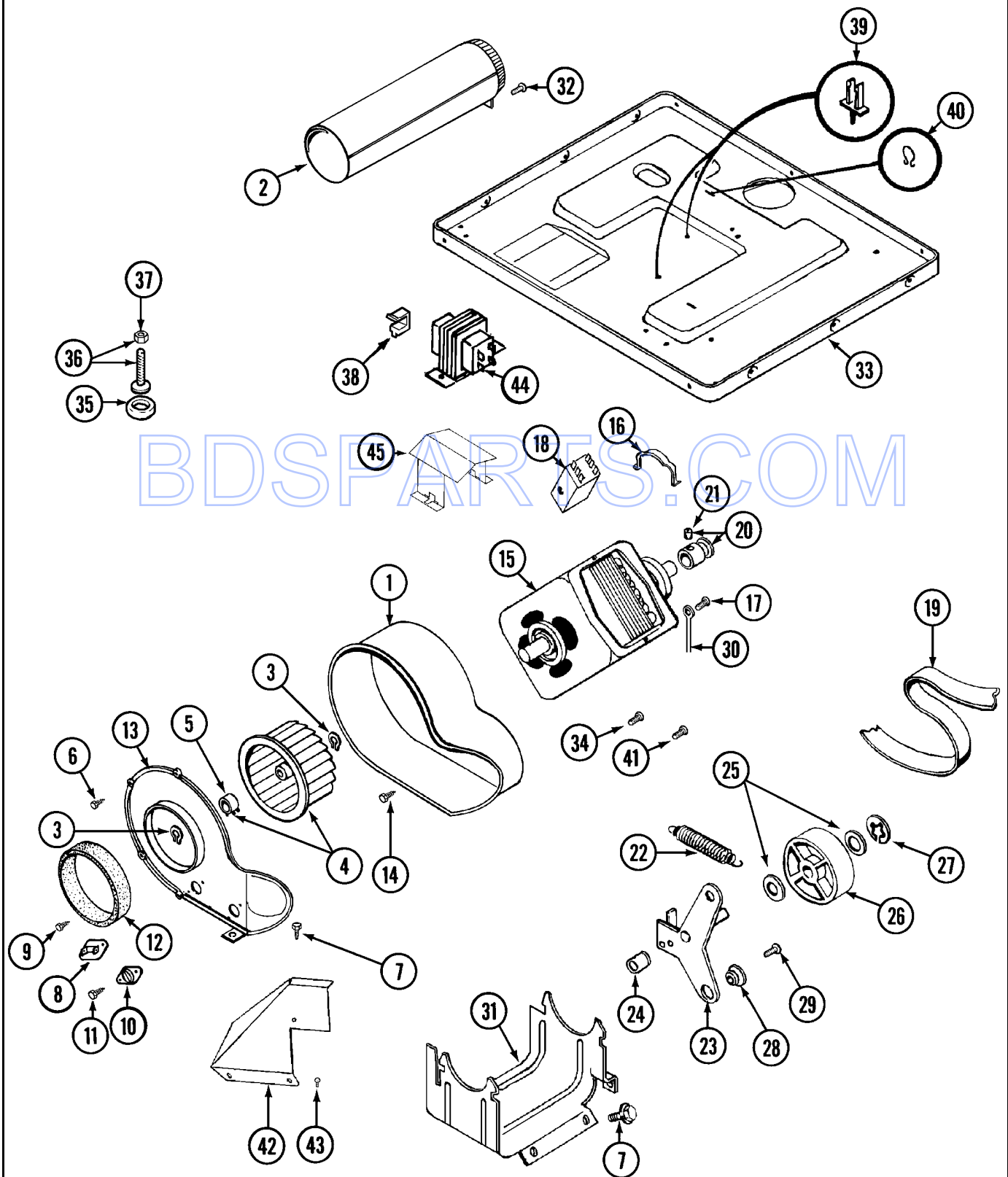

BDS PARTS.COM

## Section: MOTOR DRIVE

No.	Part No.	Description	Series	Qty
1	312893	HOUSING, BLOWER	10	2
2	303442	EXHAUST DUCT ASSY. Note: EXHAUST DUCT ASSEMBLY	10	2
3	410233	RING, RETAINING	10	4
4	303836	BLOWER WHEEL ASSEMBLY & CLAMP Note: BLOWER WHEEL ASSEMBLY	10	2
5	312967	CLAMP, BLOWER HOUSING Note: CLAMP, BLOWER WHEEL	10	2
6	312961	SCREW Note: SCREW, HOUSING COVER	10	12
7	N 313561	SCREW----NA Note: SCREW, HOUSING COVER	10	6
8	307208	THERMISTOR, TEMP. CONTROL	10	2
8	303391	CYCLING THERMOSTAT 155 DEG. Note: THERMOSTAT, CYCLING (155 DEG)	10	2
9	211294	SCREW Note: SCREW, THERMOSTATS	10	5
10	306604	CUT-OFF, THERMAL Note: CUT-OFF, THERMAL	10	2
11	314848	SCREW Note: SCREW, THERMAL CUT-OFF	10	4
12	312901	SEAL, BLOWER Note: SEAL, HOUSING COVER	10	2
13	314778	COVER FOR BLOWER Note: COVER, BLOWER HOUSING	10	2
14	314818	SCREW Note: SCREW, BLOWER HOUSING	10	8
15	303358	MOTOR	10	2
16	015825	CLIP, MOTOR	10	4
17	910343	SCREW, GROUND WIRE	10	2
18	N 306207	SWITCH, MOTOR START-PROD. Note: SWITCH, MOTOR EXTERNAL START (PROD. # 303358-8 & 303358-9)	10	2
18	303877	SWITCH, MOTOR Note: SWITCH, MOTOR EXTERNAL START (PROD. # 303358-2, 303358-4 & 303358-7)	10	2
18	303879	SWITCH, MOTOR STARTPROD. Note: SWITCH, MOTOR EXTERNAL START (PROD. # 303358 & 303358-6)	10	2
19	312959	BELT, TUMBLER & MOTOR Note: BELT, TUMBLER	10	2
20	305185	PULLEY, MOTOR (W/SET SCREW)	10	2
21	053241	SET SCREW, PULLEY Note: SCREW, SET	10	2
22	303945	IDLER SPRING ASSEMBLY Note: IDLER SPRING ASSEMBLY	10	2
23	303363	IDLER ARM & SHAFT ASSY. Note: IDLER ARM & SHAFT ASSEMBLY	10	2
24	313582	SPACER, IDLER BRACKET	10	2
25	312527	WASHER, IDLER SHAFT (QTY-1)	10	4
26	303705	PULLEY, IDLER Note: PULLEY, IDLER (W/BEARING)	10	2
27	312958	RETAINING RING, IDLER SHAFT Note: RING, RETAINING	10	2
28	N 312894	SLEEVE, IDLER ARM	10	2
29	014874	SCREW Note: SCREW, IDLER ARM	10	2
30	901220	WIRE, GROUND Note: GROUND WIRE	10	2
31	N 312897	SUPPORT, MOTOR	10	2
32	310632	SCREW Note: SCREW, EXHAUST DUCT	10	2
33	306530	BASE WELD ASSEMBLY Note: (LWR)	10	1
33	306261	BASE ASSEMBLY Note: BASE ASSEMBLY (UPR)	10	1
34	211294	SCREW Note: SCREW, GROUND WIRE	10	2
35	210684	FOOT, RUBBER	10	4
36	302699	LEG, ADJUSTABLE (W/NUT)	10	4
37	210385	NUT, LOCK Note: NUT, ADJUSTABLE LEG	10	4
38	310376	CLIP, WIRE HARNESS Note: CLIP, CABLE	10	6
39	315471	RETAINER, WIRE Note: RETAINER, WIRE HARNESS	10	6
40	410490	SPRING, WIRE HARNESS	10	5
41	312961	SCREW Note: SCREW, SPACER	10	2
42	315122	COVER, THERMOSTAT	10	2
43	310632	SCREW Note: SCREW, THERMOSTAT COVER	10	4
44	33001205	TRANSFORMER	10	1
45	315218	SHIELD, XFMR Note: SHIELD, TRANSFORMER	10	1
-	211294	SCREW Note: SCREW, TRANSFORMER	10	1

\*Color Code (-)=Not Shown #=Series, Serial Prefix or Run No., N=Not Available

Section: WIRING INFORMATION

Model: MDE13PDBCW

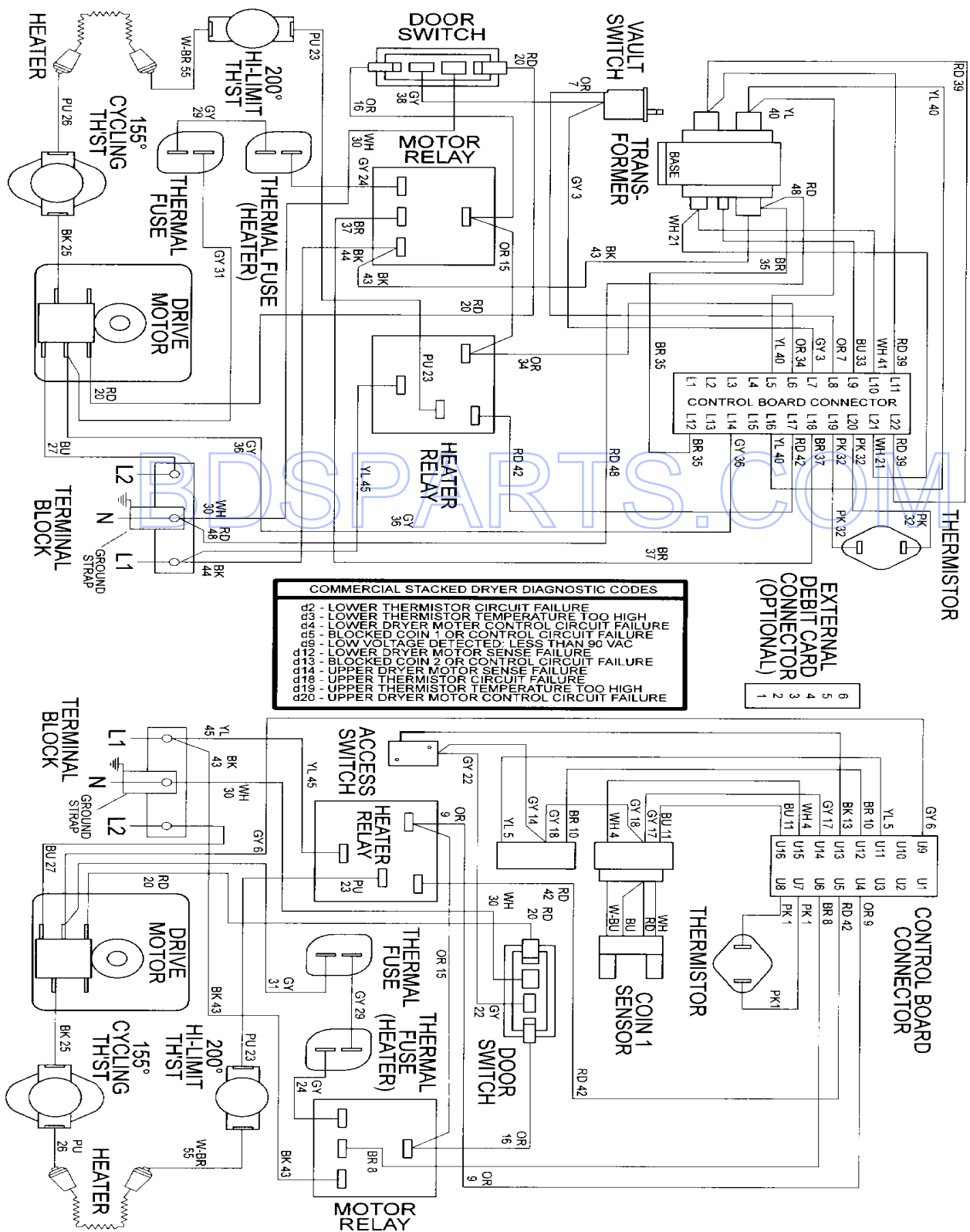

**COMMERCIAL STACKED DRYER DIAGNOSTIC CODES**

1	LOW VOLTAGE
2	NO MOTOR
3	NO HEATER
4	NO MOTOR & NO HEATER
5	NO MOTOR OR NO HEATER
6	NO MOTOR OR NO HEATER
7	NO MOTOR OR NO HEATER
8	NO MOTOR OR NO HEATER
9	NO MOTOR OR NO HEATER
10	NO MOTOR OR NO HEATER
11	NO MOTOR OR NO HEATER
12	NO MOTOR OR NO HEATER
13	NO MOTOR OR NO HEATER
14	NO MOTOR OR NO HEATER
15	NO MOTOR OR NO HEATER
16	NO MOTOR OR NO HEATER
17	NO MOTOR OR NO HEATER
18	NO MOTOR OR NO HEATER
19	NO MOTOR OR NO HEATER
20	NO MOTOR OR NO HEATER
21	NO MOTOR OR NO HEATER
22	NO MOTOR OR NO HEATER
23	NO MOTOR OR NO HEATER
24	NO MOTOR OR NO HEATER
25	NO MOTOR OR NO HEATER
26	NO MOTOR OR NO HEATER
27	NO MOTOR OR NO HEATER
28	NO MOTOR OR NO HEATER
29	NO MOTOR OR NO HEATER
30	NO MOTOR OR NO HEATER
31	NO MOTOR OR NO HEATER
32	NO MOTOR OR NO HEATER
33	NO MOTOR OR NO HEATER
34	NO MOTOR OR NO HEATER
35	NO MOTOR OR NO HEATER
36	NO MOTOR OR NO HEATER
37	NO MOTOR OR NO HEATER
38	NO MOTOR OR NO HEATER
39	NO MOTOR OR NO HEATER
40	NO MOTOR OR NO HEATER
41	NO MOTOR OR NO HEATER
42	NO MOTOR OR NO HEATER
43	NO MOTOR OR NO HEATER
44	NO MOTOR OR NO HEATER
45	NO MOTOR OR NO HEATER
46	NO MOTOR OR NO HEATER
47	NO MOTOR OR NO HEATER
48	NO MOTOR OR NO HEATER
49	NO MOTOR OR NO HEATER
50	NO MOTOR OR NO HEATER
51	NO MOTOR OR NO HEATER
52	NO MOTOR OR NO HEATER
53	NO MOTOR OR NO HEATER
54	NO MOTOR OR NO HEATER
55	NO MOTOR OR NO HEATER
56	NO MOTOR OR NO HEATER
57	NO MOTOR OR NO HEATER
58	NO MOTOR OR NO HEATER
59	NO MOTOR OR NO HEATER
60	NO MOTOR OR NO HEATER
61	NO MOTOR OR NO HEATER
62	NO MOTOR OR NO HEATER
63	NO MOTOR OR NO HEATER
64	NO MOTOR OR NO HEATER
65	NO MOTOR OR NO HEATER
66	NO MOTOR OR NO HEATER
67	NO MOTOR OR NO HEATER
68	NO MOTOR OR NO HEATER
69	NO MOTOR OR NO HEATER
70	NO MOTOR OR NO HEATER
71	NO MOTOR OR NO HEATER
72	NO MOTOR OR NO HEATER
73	NO MOTOR OR NO HEATER
74	NO MOTOR OR NO HEATER
75	NO MOTOR OR NO HEATER
76	NO MOTOR OR NO HEATER
77	NO MOTOR OR NO HEATER
78	NO MOTOR OR NO HEATER
79	NO MOTOR OR NO HEATER
80	NO MOTOR OR NO HEATER
81	NO MOTOR OR NO HEATER
82	NO MOTOR OR NO HEATER
83	NO MOTOR OR NO HEATER
84	NO MOTOR OR NO HEATER
85	NO MOTOR OR NO HEATER
86	NO MOTOR OR NO HEATER
87	NO MOTOR OR NO HEATER
88	NO MOTOR OR NO HEATER
89	NO MOTOR OR NO HEATER
90	NO MOTOR OR NO HEATER
91	NO MOTOR OR NO HEATER
92	NO MOTOR OR NO HEATER
93	NO MOTOR OR NO HEATER
94	NO MOTOR OR NO HEATER
95	NO MOTOR OR NO HEATER
96	NO MOTOR OR NO HEATER
97	NO MOTOR OR NO HEATER
98	NO MOTOR OR NO HEATER
99	NO MOTOR OR NO HEATER
100	NO MOTOR OR NO HEATER

**EXTERNAL DEBIT CARD CONNECTOR (OPTIONAL)**

1	1
2	2
3	3
4	4
5	5
6	6



