

DRYER

Repair Parts List

MODEL NUMBER
MDE16CSAZW

When requesting service or ordering parts, always provide the following information:

- Product Type
- Part Number
- Model Number
- Part Description

MAYTAG®

©2005 Maytag Services

Section: CONTROL PANEL

Model: MDE16CSAZW

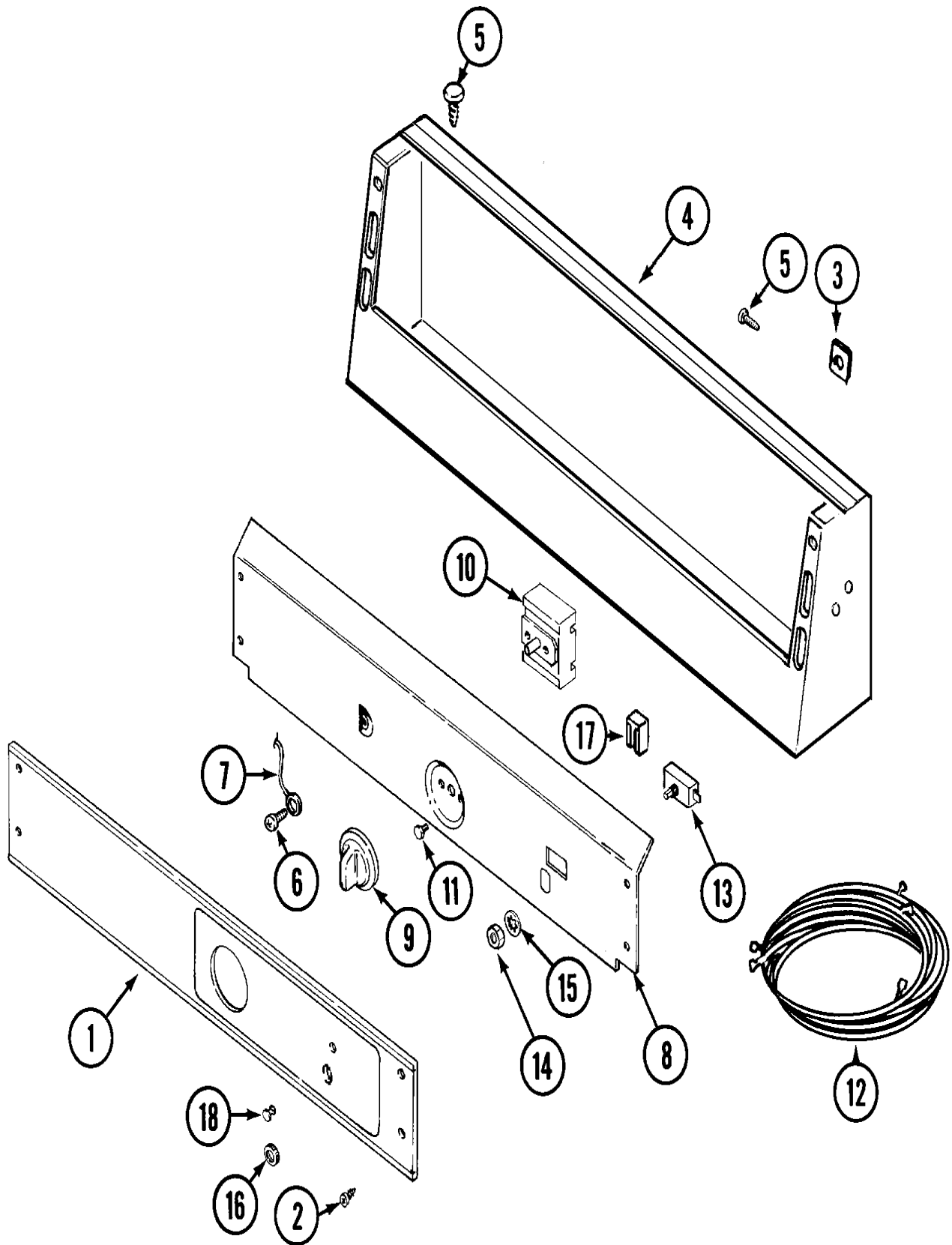

CD11-1

Section: CONTROL PANEL

No.	Part No.	Description	Series	Qty
1	N 33001958	PANEL, CONTROL	10	1
2	215506	SCREW, TORX Note: SCREW, CONTROL PANEL	10	4
3	215506	SCREW, TORX Note: FASTENER, CONTROL PANEL	10	2
4	22003089	CONSOLE (WHT)	29	1
4	22002329	CONSOLE (WHT)	10	1
5	212276	SCREW Note: SCREW, CONSOLE	10	4
6	211252	SCREW Note: SCREW, GROUND WIRE	10	1
7	205810	WIRE, GROUND	10	1
8	33001959	BRACKET, BACK (WHT)	10	1
8	33002522	BRACKET, BACK (WHT) Note: BRACKET, BACK (WHT)	29	1
9	306938	KNOB, SELECTOR SWITCH	10	1
10	307237	SWITCH, CYCLE SELECTOR	10	1
11	313588	SCREW Note: SCREW, SELECTOR SWITCH	10	2
12	33001961	WIRE HARNESS, MAIN	10	1
12	33002240	WIRE HARNESS, MAIN	19	1
13	306940	SWITCH, PUSH-TO-START	10	1
14	312706	HEX NUT ON SWITCH Note: NUT, SWITCH	10	1
15	312751	LOCK WASHER Note: WASHER, LOCK	10	1
16	312702	KNURLED NUT Note: NUT, KNURLED	10	1
17	204075	LIGHT, INDICATOR Note: LAMP, INDICATOR	10	1
18	215564	LENS, INDICATOR (AMBER) Note: LENS, INDICATOR	10	1
-	16009021	MANUAL, SERVICE-NO REFUND	10	1

*Color Code (-)=Not Shown #=Series, Serial Prefix or Run No., N=Not Available

Section: CABINET-FRONT

Model: MDE16CSAZW

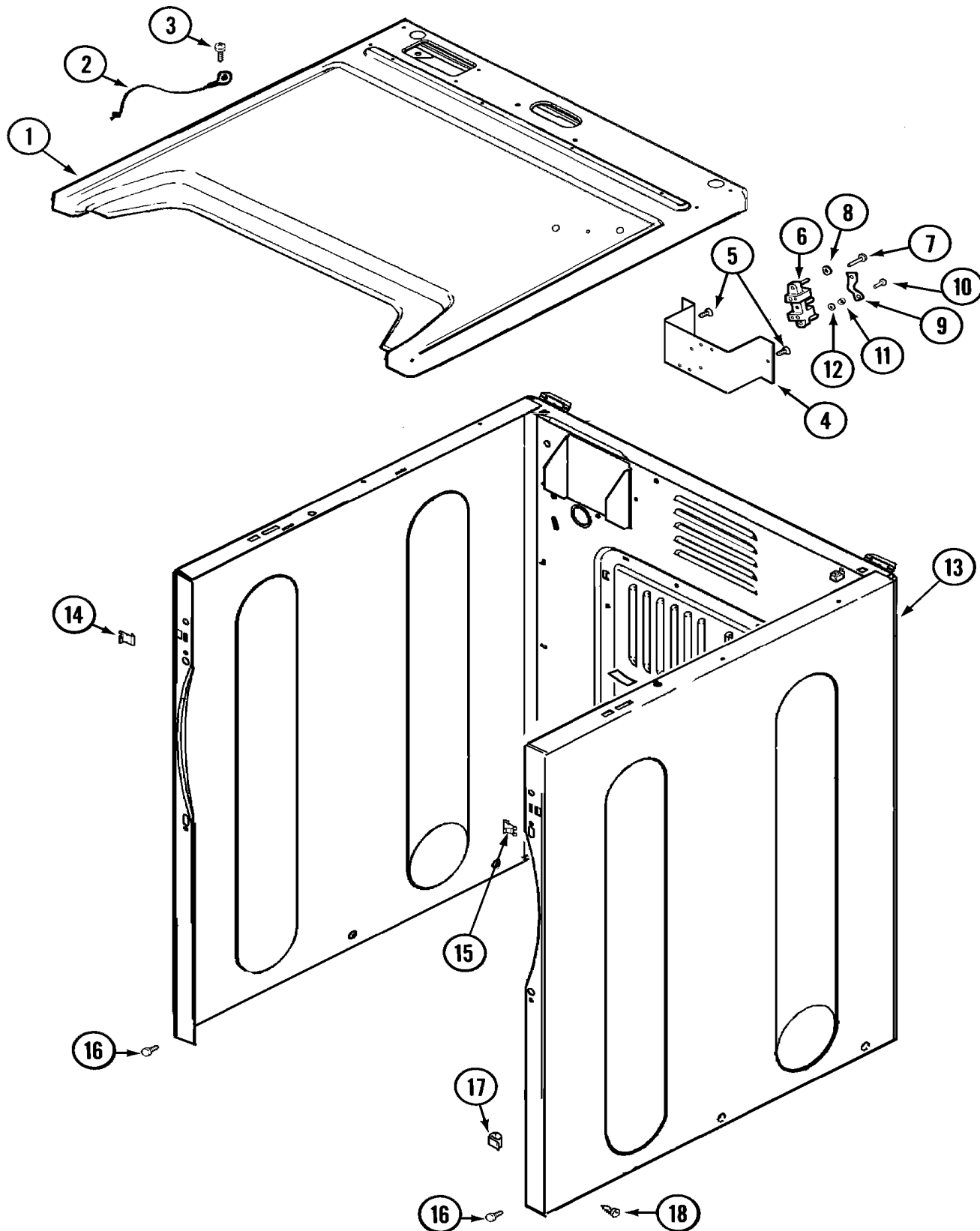

LD12-59

Section: CABINET-FRONT

No.	Part No.	Description	Series	Qty
1	33002633	COVER, TOP (WHT-AS PK)	36	1
1	33001949	COVER, TOP (WHT)	10	1
2	22001959	WIRE, GROUND	10	1
3	210186	SCREW, GROUND WIRE TO BASE--NA Note: SCREW, GROUND WIRE	10	1
4	N 33001826	BRACKET, TERMINAL BLOCK---NA	10	1
5	22001995	SCREW Note: SCREW, TERMINAL BLOCK BRACKET	10	2
6	33001244	BLOCK, TERMINAL	10	1
7	312209	SCREW, #10-24 X 3/4 INCH Note: SCREW, TERMINAL BLOCK	10	2
9	312184	STRAP, GROUND	10	1
10	N 33001245	SCREW----NA Note: SCREW, GROUND STRAP	10	1
11	311484	NUT, TERMINAL BLOCK	10	3
12	311093	WASHER, 7/32 INCH Note: WASHER, TERMINAL BLOCK	10	3
13	N 33002624	CABINET, ASSY. (WHT-AS PK)	36	1
13	N 22003643	CABINET ASSY. (WHT AS PK)	38	1
13	N 33001897	CABINET (WHT)	10	1
14	22002049	CLIP	10	2
15	213280	FRONT PANEL BRACKET/FASTENER Note: RETAINER, SHROUD	10	2
16	22001995	SCREW Note: SCREW, CABINET	10	2
17	310376	CLIP, WIRE HARNESS	10	1
18	22003409	SCREW----NA Note: SCREW, CABINET (TRUSS)	36	6
18	213007	SCREW, CABINET	10	6

*Color Code (-)=Not Shown #=Series, Serial Prefix or Run No., N=Not Available

Section: DOOR

No.	Part No.	Description	Series	Qty
1	33001767	SEAL, SHROUD	10	1
2	22002247	HOOK, SECURITY	10	2
3	33001900	SHROUD (WHT)	10	1
4	22001995	SCREW Note: SCREW, TUMBLER FRONT & SHROUD	10	10
5	33001768	SCREW, SHROUD Note: SCREW, SHROUD & OUTLET DUCT	10	2
6	33001509	SWITCH, DOOR	10	1
7	33001760	BRACKET, HINGE	10	4
8	N 33001174	PLUG, DOOR CATCH	10	1
9	304578	CATCH, DOOR (FEMALE)	10	1
10	33002094	SEAL, DOOR	10	1
11	33001268	PAD, DOOR	10	1
12	22002038	CLIP, DOOR (DOUBLE)	10	4
13	33001771	BUSHING, INNER DOOR	10	2
14	33001793	BRACKET, STRIKE	10	1
15	33001761	STRIKE, DOOR (MALE)	10	1
16	22002039	CLIP, DOOR (SINGLE)	10	2
17	33001763	PLUG, INNER DOOR	10	1
-	22002063	SCREW #8-18AB WAFER HD	10	2
-	22002039	CLIP, DOOR (SINGLE)	10	2
18	33001899	DOOR, INNER (WHT)	10	1
19	33001904	DOOR, OUTER (WHT) Note: DOOR, OUTER (WHT)	10	1
20	33001759	HINGE, DOOR	10	2
21	22002062	SCREW Note: SCREW, HINGE	10	4
22	22002063	SCREW #8-18AB WAFER HD	10	8
23	33001764	COVER, HINGE HOLE (WHT)	10	2
24	33001846	SCREW Note: SCREW, HINGE HOLE COVER	10	2
25	22002243	SCREW Note: SCREW, HINGE BRACKET	10	2
-	22002244	CLIP, GROUNDING	10	1
-	22002239	CLIP, LOWER FRONT PANEL	10	2
26	33001901	PANEL, FRONT (WHT)	10	1
-	213280	FRONT PANEL BRACKET/FASTENER Note: FASTENER, FRONT PANEL	10	2

*Color Code (-)=Not Shown #=Series, Serial Prefix or Run No., N=Not Available

Section: CABINET-REAR

Model: MDE16CSAZW

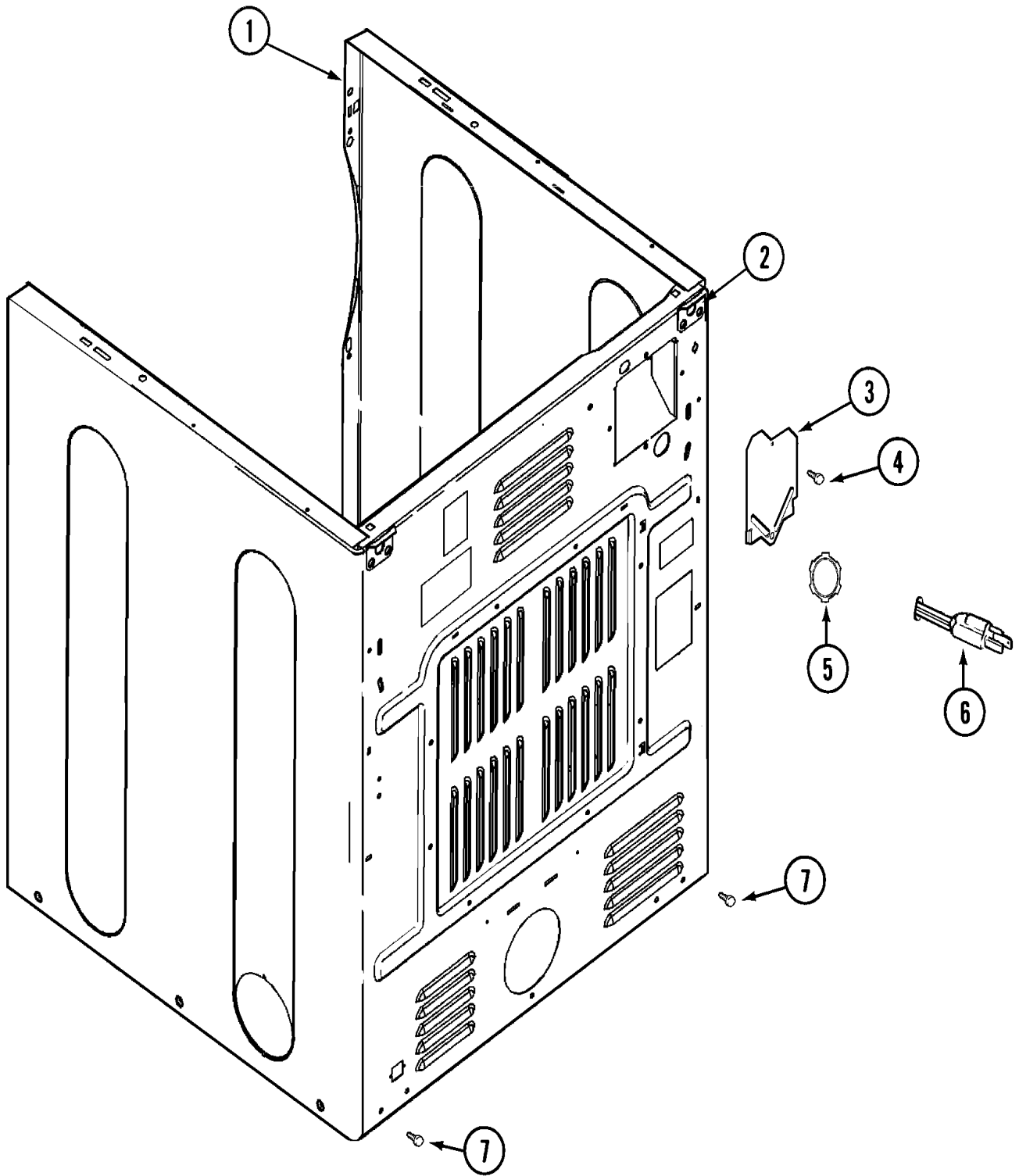

LD12-60

Section: CABINET-REAR

No.	Part No.	Description	Series	Qty
1	N 33001897	CABINET (WHT)	10	1
1	N 33002624	CABINET, ASSY. (WHT-AS PK)	36	1
2	N 33001827	BRACKET, CABINET HINGE	10	2
-	22003367	HINGE, PLASTIC	36	2
-	22001995	SCREW	36	2
3	33001795	COVER, TERMINAL BLOCK	10	1
4	22001995	SCREW Note: SCREW, TERMINAL BLOCK COVER	10	1
5	33001425	LOCKNUT, EARED FOR CANADIAN	10	1
6	305168	CORD, POWER (CANADA)	10	1
7	22001995	SCREW Note: SCREW, CABINET	10	2

*Color Code (-)=Not Shown #=Series, Serial Prefix or Run No., N=Not Available

Section: TUMBLER

Model: MDE16CSAZW

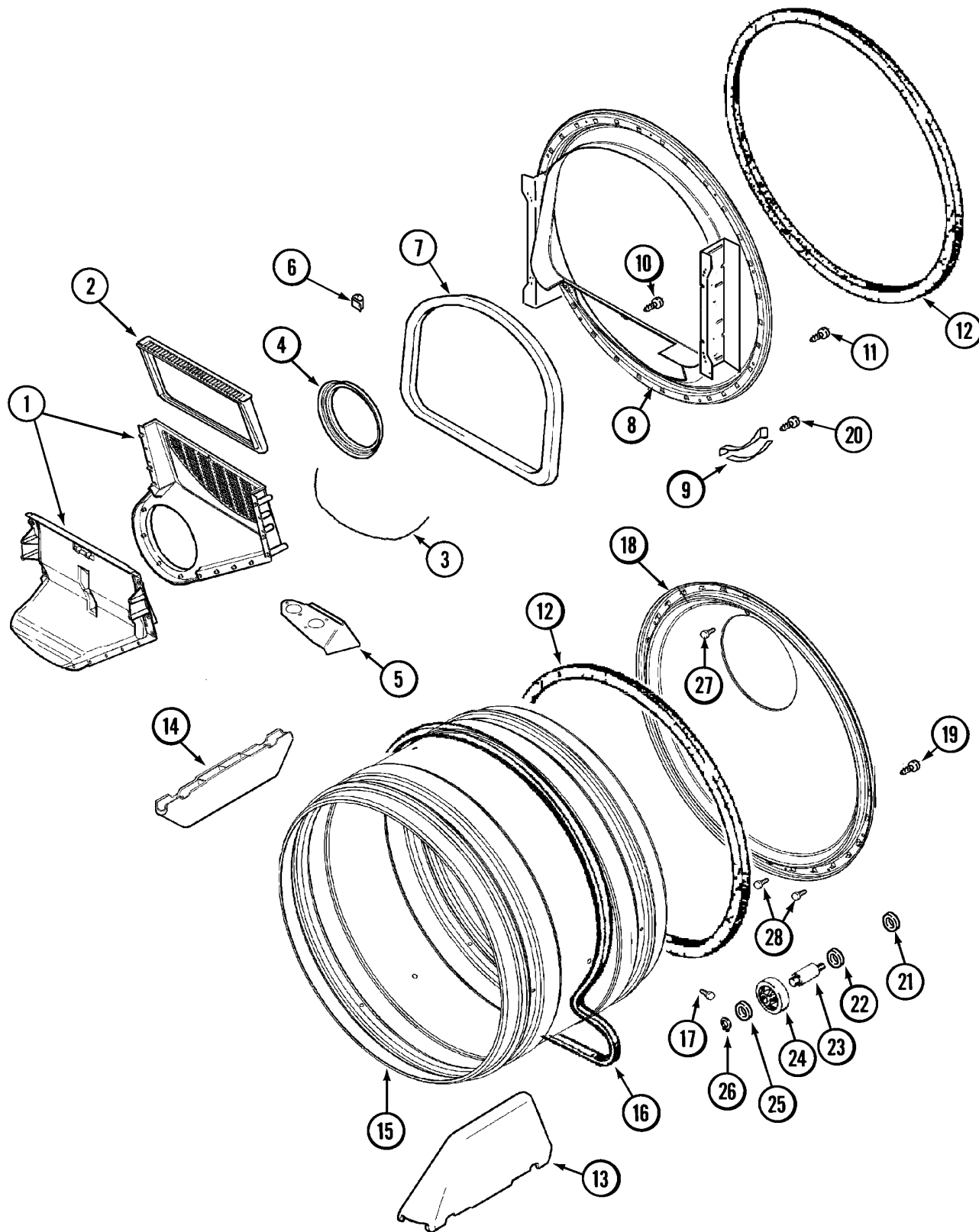

Section: TUMBLER

No.	Part No.	Description	Series	Qty
1	33001799	OUTLET DUCT ASSEMBLY	10	1
2	33001804	FILTER, LINT	10	1
3	N 33001775	SEAL, OUTLET DUCT	10	1
4	33001758	SEAL, BLOWER	10	1
5	33001837	COVER, THERMOSTAT (ELEC ONLY)	10	1
6	310376	CLIP, WIRE HARNESS	10	1
7	33001767	SEAL, SHROUD	10	1
8	33001802	FRONT, TUMBLER (W/SEAL)	10	1
9	306508	TUMBLER BEARING KIT	10	2
10	N 312311	SCREW----NA Note: SCREW, OUTLET DUCT	10	1
11	33001855	SCREW (HEX HEAD) Note: SCREW, OUTLET DUCT	10	4
12	33001807	SEAL, TUMBLER	10	2
13	33001756	BAFFLE (TALL)	10	2
14	33001755	BAFFLE (SHORT)	10	1
15	33001794	TUMBLER	10	1
16	33001777	BELT, TUMBLER	10	1
17	33001788	SCREW, BAFFLE	10	6
18	33001801	BACK, TUMBLER (W/SEAL)	10	1
19	22001995	SCREW Note: SCREW, TUMBLER BACK	10	4
20	210720	RIVET	10	4
21	33001443	NUT, HEX (ROLLER SHAFT)	10	2
22	313347	WASHER, SPRING (ROLLER SHAFT)	10	2
23	312948	SHAFT, TUMBLER ROLLER	10	2
24	303373	BEARING & ROLLER ASSEMBLY Note: ROLLER (W/BEARING)	10	2
25	312535	WASHER, ROLLER SHAFT	10	2
26	410233	RING, RETAINING	10	2
27	210932	SCREW, #8 X 9/16 CTSK Note: SCREW, INLET DUCT	10	1
28	22001996	SCREW Note: SCREW, INLET DUCT	10	2

*Color Code (-)=Not Shown #=Series, Serial Prefix or Run No., N=Not Available

Section: HEATER

Model: MDE16CSAZW

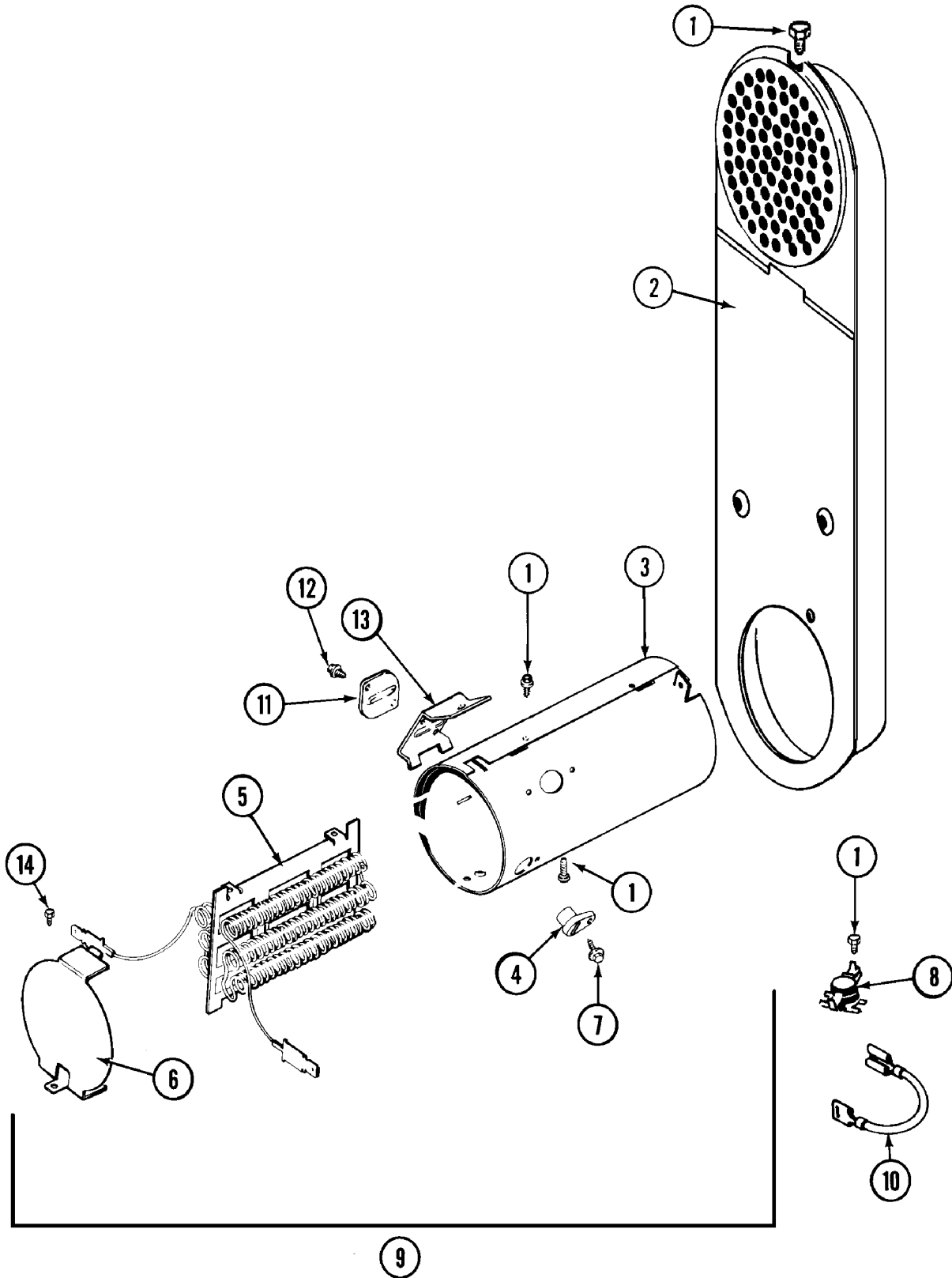

Section: HEATER

No.	Part No.	Description	Series	Qty
1	211294	SCREW Note: SCREW, HEATER	10	7
2	33001803	DUCT ASSY., INLET	10	1
3	314995	HEATER ENCLOSURE	10	1
4	314998	INSULATOR, TERMINAL	10	2
5	307184	HEATER SUB-ASSEMBLY (240V)	10	1
6	314999	SHIELD, RADIANT	10	1
7	N 314554	SCREW Note: SCREW, TERMINAL INSULATOR	10	2
8	303396	THERMOSTAT, HI-LIMIT (ELEC)	10	1
9	307178	HEATER ASSEMBLY(COMPLETE 240V)	10	1
10	307173	WIRE, JUMPER	10	1
11	307473	FUSE, THERMAL	10	1
12	314848	SCREW Note: SCREW	10	3
13	315346	BRACKET, THERMAL FUSE	10	1
14	22001996	SCREW Note: SCREW, RADIANT SHIELD	10	2
-	308590	CONVERSION KIT (240V TO 208V)	10	1

*Color Code (-)=Not Shown #=Series, Serial Prefix or Run No., N=Not Available

Section: MOTOR DRIVE

Model: MDE16CSAZW

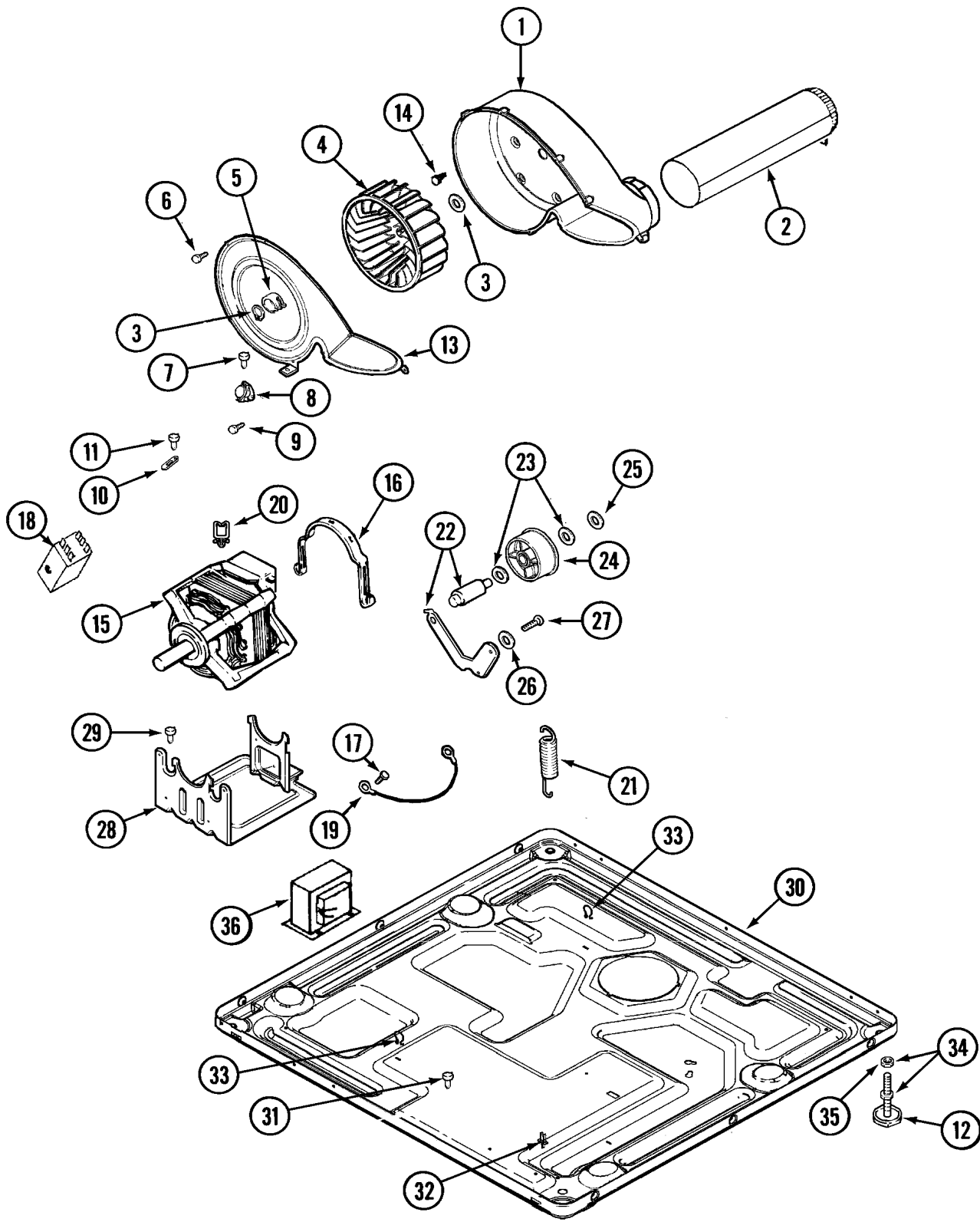

LD14-43

Section: MOTOR DRIVE

No.	Part No.	Description	Series	Qty
1	33001789	HOUSING, BLOWER	10	1
-	22001995	SCREW Note: SCREW, EXHAUST DUCT ASSEMBLY	10	1
2	33001800	DUCT ASSY., EXHAUST	10	1
3	410233	RING, RETAINING	10	2
4	33002797	WHEEL, BLOWER	68	1
4	33001790	WHEEL, BLOWER	10	1
5	312967	CLAMP, BLOWER HOUSING	10	1
6	33001855	SCREW (HEX HEAD) Note: SCREW, HOUSING COVER	10	8
7	N 313561	SCREW----NA Note: SCREW, HOUSING COVER	10	3
8	306967	THERMOSTAT, MULTI-TEMP Note: THERMOSTAT, MULTI-TEMP.	10	1
8	303392	CYCLING THERMOSTAT 140 DEG. Note: THERMOSTAT, CYCLING	10	1
-	33001306	HARNESS, WIRE Note: WIRE HARNESS, THERMOSTAT	10	1
9	22001996	SCREW Note: SCREW, THERMOSTAT	10	4
10	33001762	FUSE, THERMAL (W' BRACKET)	10	1
11	314848	SCREW Note: SCREW, THERMAL CUT-OFF	10	1
12	314137	FOOT, RUBBER	10	4
13	33001796	COVER, BLOWER HOUSING	10	1
14	314818	SCREW Note: SCREW, BLOWER HOUSING	10	4
15	33002795	MOTOR, DRIVE 60HZ	68	1
15	33001853	MOTOR (W/PULLEY) Note: MOTOR (W/V PULLEY)	10	1
15	33002237	MOTOR (W/PULLEY)	23	1
15	33002462	MOTOR (120V 60HZ)	26	1
15	33002478	MOTOR	28	1
16	015825	CLIP, MOTOR	10	2
18	33001854	SWITCH, MOTOR	10	1
20	310376	CLIP, WIRE HARNESS	10	1
21	33001754	SPRING, IDLER	10	1
-	33002157	GROMMET	10	1
21	33002460	SPRING, IDLER Note: SPRING & PLUG KIT 33002459	25	1
-	33002461	PLUG FOR SPRING	25	1
22	33001782	IDLER ARM & SHAFT ASSY.	10	1
23	312527	WASHER, IDLER SHAFT (QTY-1)	10	2
24	33001783	BEARING, IDLER ASSEMBLY	10	1
25	312958	RETAINING RING, IDLER SHAFT	10	1
26	315772	SLEEVE, IDLER ARM	10	1
27	014874	SCREW Note: SCREW, IDLER ARM SLEEVE	10	1
-	N 313561	SCREW----NA	25	1
28	33001752	SUPPORT, MOTOR	10	1
28	33002466	SUPPORT, MOTOR	25	1
29	N 313561	SCREW----NA Note: SCREW, MOTOR & BLOWER	10	2
30	N 33002465	BASE, (LWR)----NA	25	1
30	33002622	BASE, (LWR)	36	1
30	33001845	BASE Note: BASE	10	1
30	N 33002465	BASE, (LWR)----NA	38	1
31	22001078	SCREW Note: SCREW, RELAY & BASE	10	2
32	315471	RETAINER, WIRE	10	1
33	410490	SPRING, WIRE HARNESS	10	2
34	305086	ADJUSTABLE LEG & NUT	10	4
35	052740	NUT Note: NUT, LEG	10	4

*Color Code (-)=Not Shown #=Series, Serial Prefix or Run No., N=Not Available

Section: CONTROL CENTER

Model: MDE16CSAZW

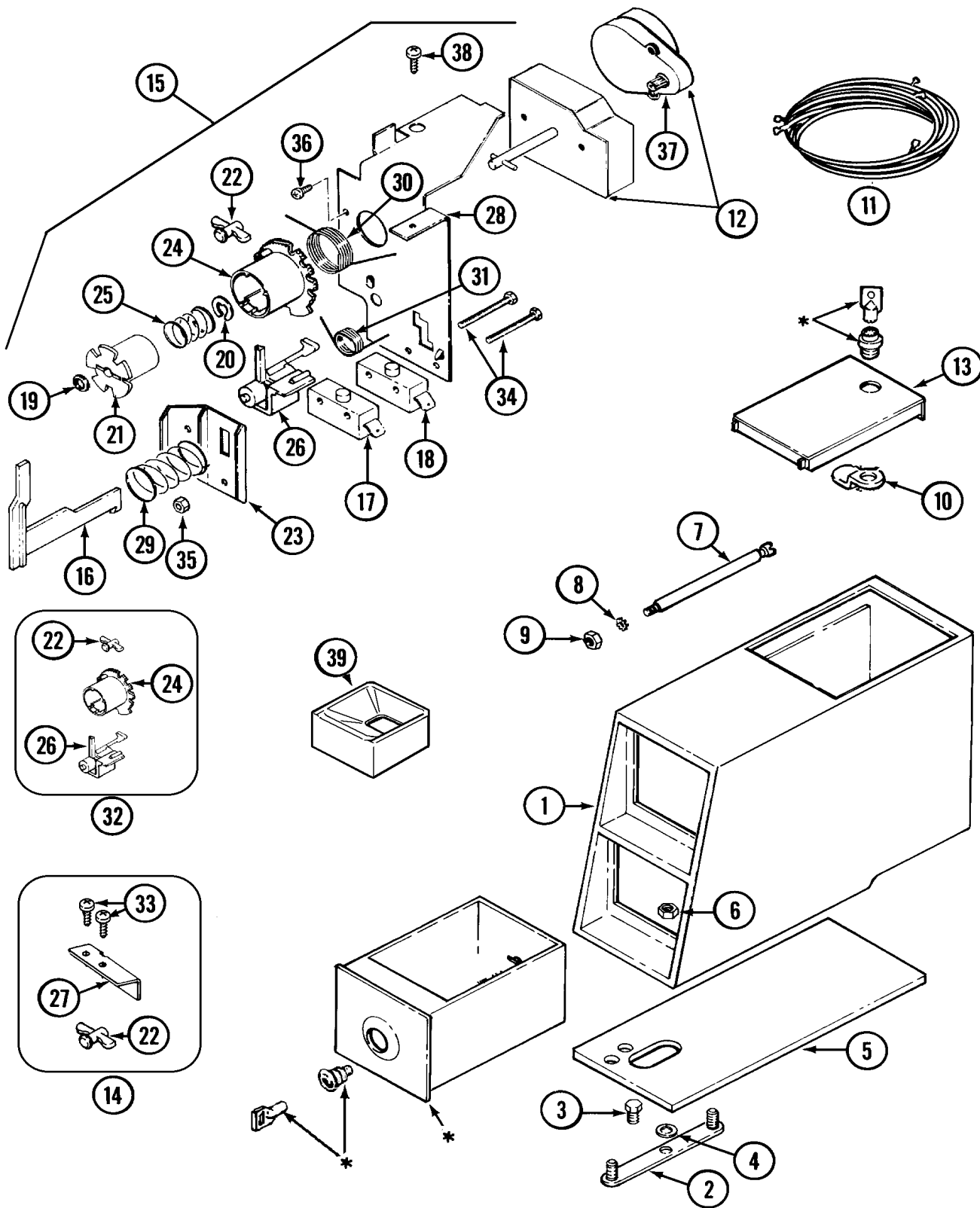

* CONTACT YOUR COMMERCIAL LAUNDRY DISTRIBUTOR

Section: CONTROL CENTER

No.	Part No.	Description	Series	Qty
1	22002478	VAULT, COIN (WHT)CS Note: VAULT, COIN (WHT)	21	1
2	22001810	STRAP, MOUNTING	10	1
3	211294	SCREW Note: SCREW, MOUNTING STRAP	10	1
4	910309	WASHER Note: WASHER, STRAP SCREW	10	1
5	22002072	GASKET, CONTROL CENTER (WHT)	10	1
6	052740	NUT Note: NUT, CASE MOUNTING	10	1
7	22001903	LOCKING BOLT, COIN SLIDE Note: BOLT, LOCKING	10	1
8	910387	LOCK WASHER Note: LOCKWASHER, LOCKING BOLT	10	1
8	910387	LOCK WASHER Note: LOCKWASHER, LOCKING BOLT	21	2
9	052721	NUT Note: NUT, LOCKING BOLT	10	1
9	052721	NUT Note: NUT, LOCKING BOLT	21	2
10	N 22001905	CAM, LOCKING	10	1
11	33001195	WIRE HARNESS, TIMER	10	1
12	33001155	TIMER	10	1
13	22001910	DOOR, ACCESS (WHT)	10	1
-	22001882	LATCH, ACCESS DOOR	10	1
-	22001883	SCREW	10	1
-	22001881	GROMMET, DOUBLE	10	1
14	33001688	ACTUATOR KIT, DRYER Note: ACTUATOR KIT	10	1
15	33001275	TORSION TIMER ASSY. Note: TORSION TIMER ASSEMBLY	10	1
16	314337	SLIDER	10	1
17	305798	BYPASS SWITCH FOR MOTOR Note: SWITCH, BY-PASS (MOTOR)	10	1
18	305799	BYPASS SWITCH FOR HEATER Note: SWITCH, BY-PASS (HEATER)	10	1
19	211790	LOCK RING FOR TIMER SHAFT Note: RETAINER, SPRING	10	1
20	312270	E CLIP Note: CLIP, SPRING RETAINER	10	1
21	314330	DRIVER FOR INDEX WHEEL Note: DRIVER, INDEX WHEEL	10	1
22	314547	ADJUSTMENT RETURN STOP Note: STOP, ADJUSTABLE RETURN	10	1
22	314335	TIME ADJUSTMENT PEG Note: PEG, TIME ADJUSTMENT	10	1
23	314339	SWITCH AND SLIDER BRACKET Note: BRACKET, SWITCH & SLIDER	10	1
24	314546	INDEX WHEEL Note: WHEEL, INDEX	10	1
25	211065	SPRING, TIMER KNOB Note: SPRING, INDEX WHEEL	10	1
26	314548	ACTUATOR, SWITCH Note: ACTUATOR, SWITCH	10	1
27	33001708	BRACKET, COIN SLIDE	10	1
28	33001207	BRACKET, TIMER	10	1
29	314340	HELICAL SPRING Note: SPRING, HELICAL	10	1
30	314331	RETURN SPRING Note: SPRING, TORSION RETURN	10	1
31	314332	ACTUATOR SPRING Note: SPRING, ACTUATOR	10	1
32	306104	TORSION-TIMER KIT Note: ACTUATOR KIT	10	1
33	212707	SCREW Note: SCREW, SLIDE BRACKET	10	2
34	315277	SCREW Note: SCREW, BY-PASS SWITCHES	10	2
35	052634	HEX. NUT, #6-32 Note: NUT, BY-PASS SWITCHES	10	2
36	910708	SCREW -RELAY TO TUB SUPPORT Note: SCREW, TIMER	10	2
37	308991	MOTOR, TIMER	10	1
38	211168	SCREW, #8 X 5/16 INCH Note: SCREW, TIMER BRACKET	10	1
-	22002534	BOLT, CARRIAGE	21	1
39	22001878	CHUTE, COIN Note: (REMOVED AT SERIES 21)	10	1
39	22002533	WELD ASSY., FUNNEL	21	1
-	22001917	PLATE, ADAPTOR (WHT) Note: (REMOVED AT SERIES 21)	10	1
-	22001904	BRACE, COIN SLIDE Note: (REMOVED AT SERIES 21)	10	1

*Color Code (-)=Not Shown #=Series, Serial Prefix or Run No., N=Not Available

Section: WIRING INFORMATION

Model: MDE16CSAZW

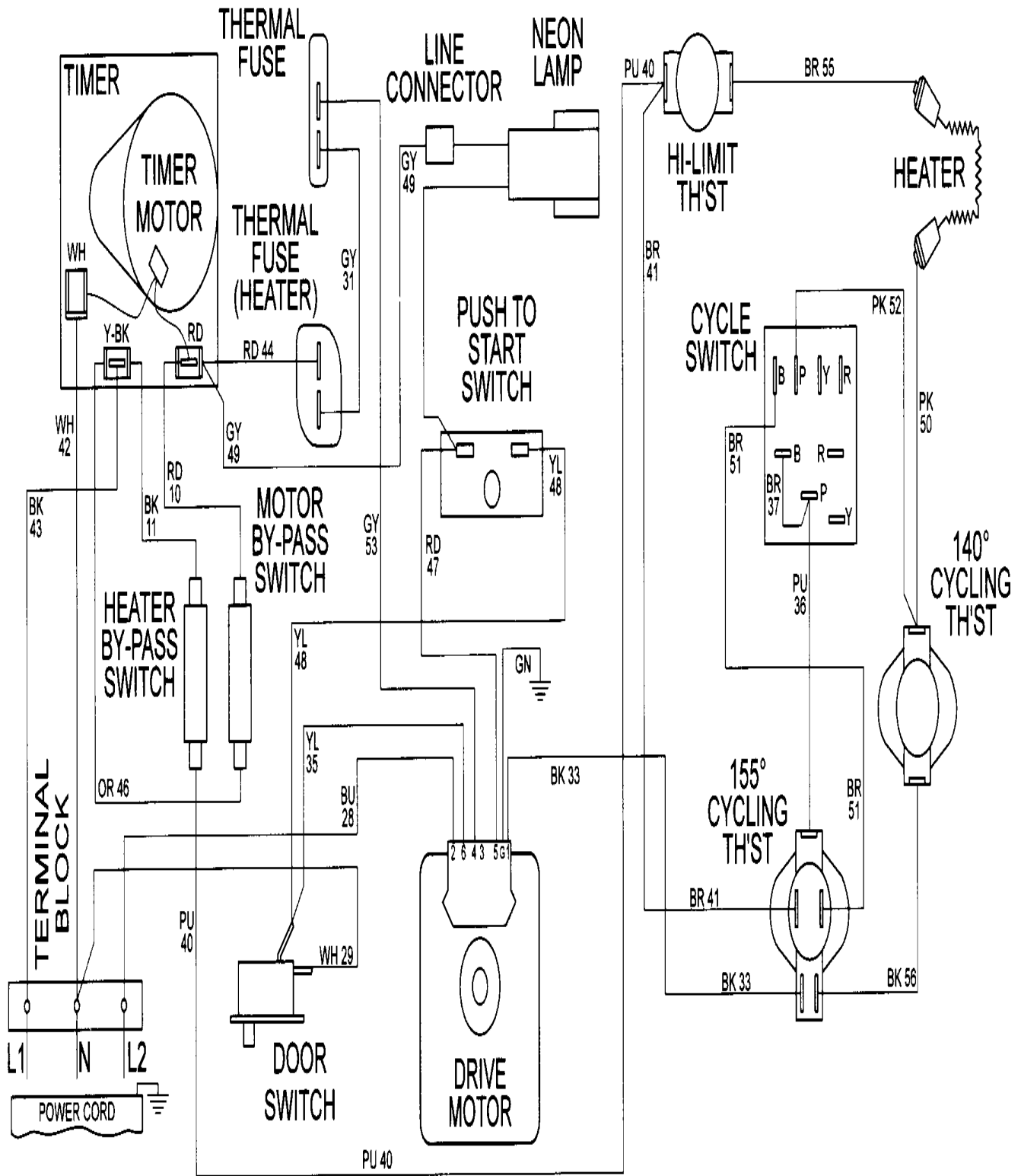

15002375

Section: WIRING INFORMATION (SER PRE 19)

Model: MDE16CSAZW

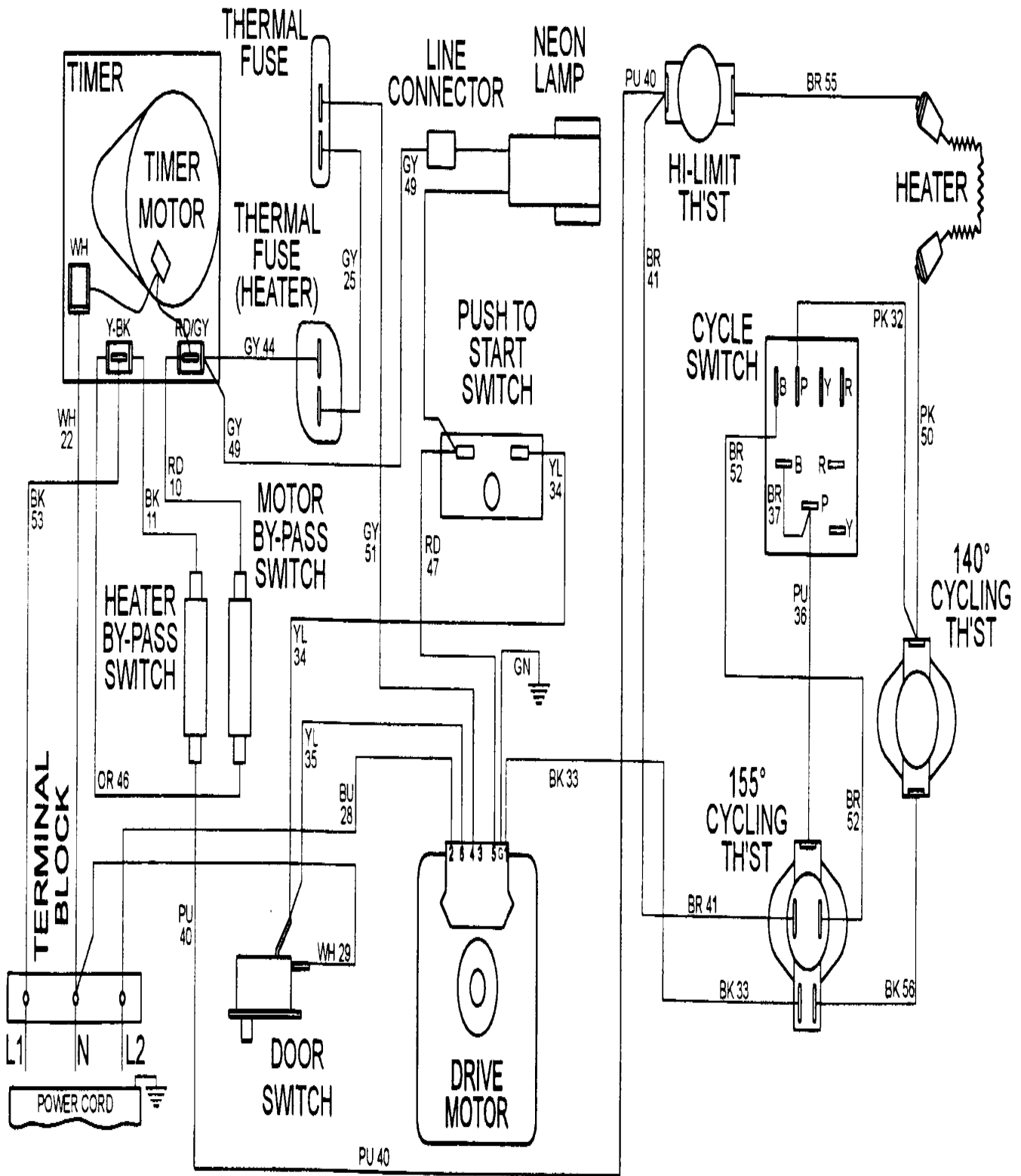

15002496

Section: WIRING INFORMATION (SER PRE 19)

No.	Part No.	Description	Series Qty
-	N 15002496	WIRING INFORMATION	19 1

*Color Code (-)=Not Shown #=Series, Serial Prefix or Run No., N=Not Available

Section: WIRING INFORMATION (MDE16CSAYQ)

Model: MDE16CSAZW

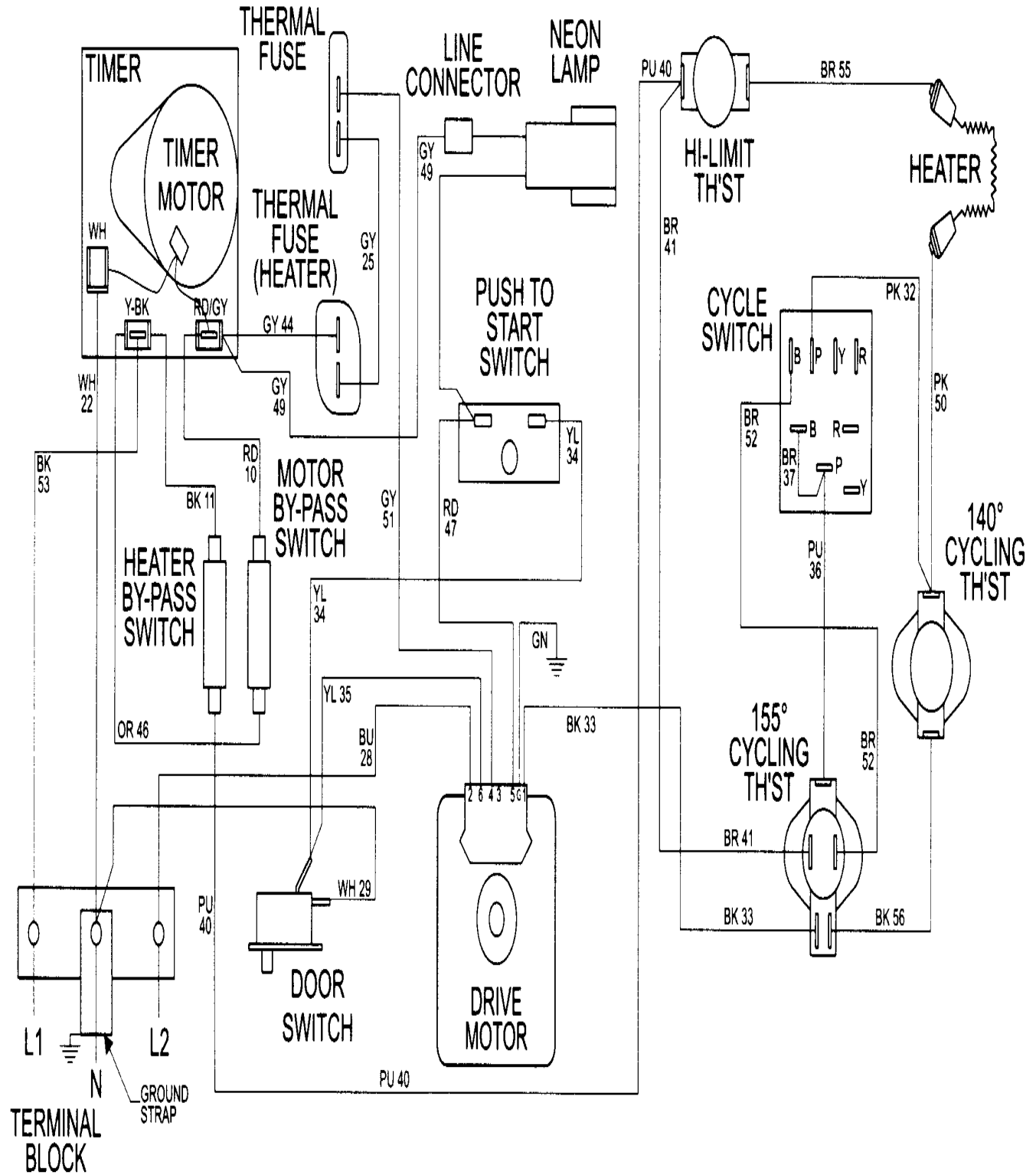

15002495

Section: WIRING INFORMATION (MDE16CSAYQ)

No.	Part No.	Description	Series Qty	
-	N 15002495	WIRING INFORMATION	23	1

*Color Code (-)=Not Shown #=Series, Serial Prefix or Run No., N=Not Available

