

DRYER

Repair Parts List

MODEL NUMBER

MDG16CSBWW

BDSPARTS.COM

When requesting service or ordering parts, always provide the following information:

- Product Type
- Part Number
- Model Number
- Part Description

MAYTAG®

©2005 Maytag Services

Section: CONTROL PANEL

Model: MDG16CSBWW

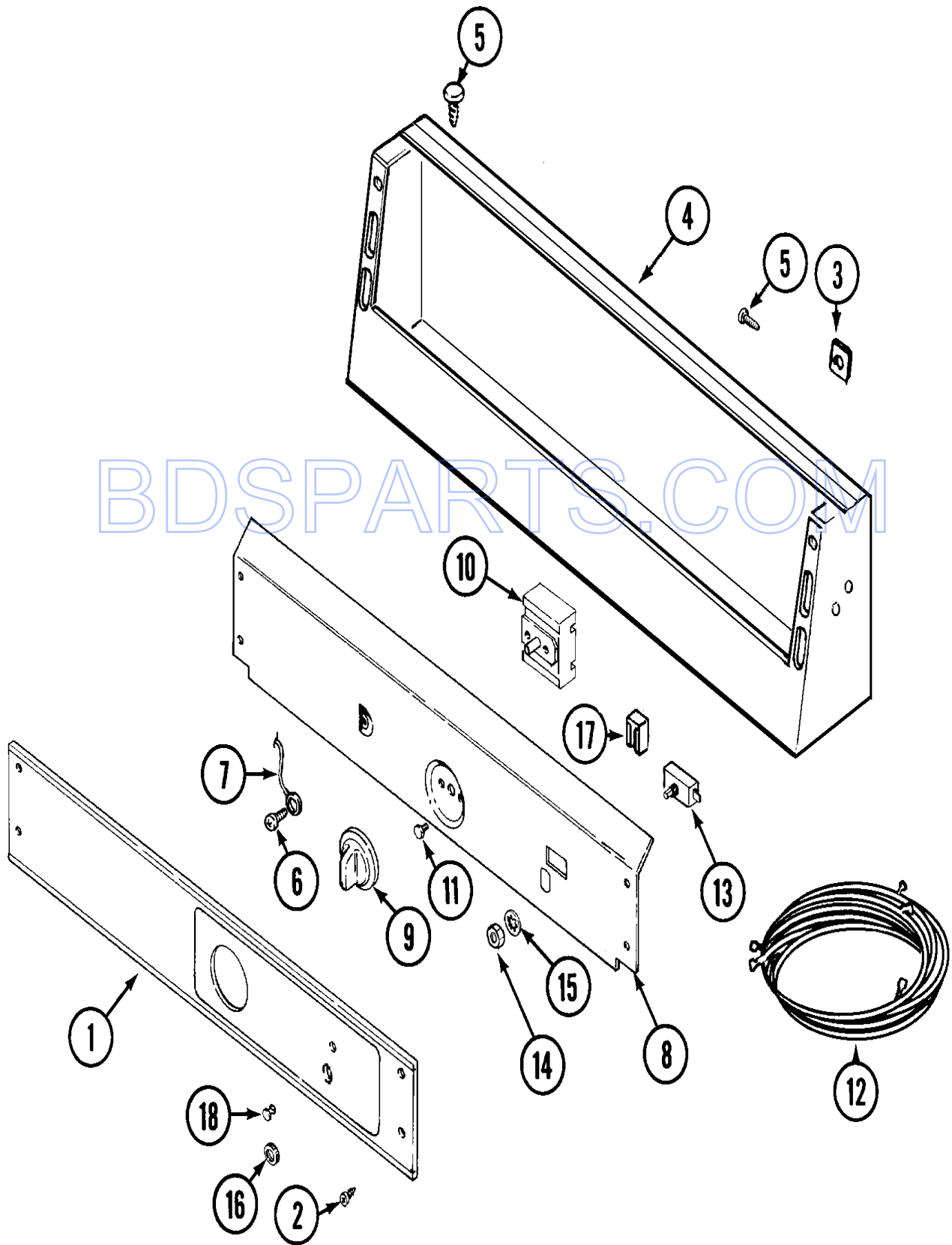

CD11-1

Section: CONTROL PANEL

No.	Part No.	Description	Series	Qty
1	N 33001958	PANEL, CONTROL	10	1
2	215506	SCREW, TORX Note: SCREW, CONTROL PANEL	10	4
3	215506	SCREW, TORX Note: FASTENER, CONTROL PANEL	10	2
4	22003089	CONSOLE (WHT)	10	1
5	212276	SCREW Note: SCREW, CONSOLE	10	4
6	211252	SCREW Note: SCREW, GROUND WIRE	10	1
7	205810	WIRE, GROUND	10	1
8	33002522	BRACKET, BACK (WHT) Note: BRACKET, BACK (WHT)	10	1
9	306938	KNOB, SELECTOR SWITCH	10	1
10	307237	SWITCH, CYCLE SELECTOR	10	1
11	313588	SCREW Note: SCREW, SELECTOR SWITCH	10	2
12	33001195	WIRE HARNESS, TIMER	10	1
12	33002244	WIRE HARNESS, MAIN	10	1
13	306940	SWITCH, PUSH-TO-START	10	1
14	Y312706	HEX NUT ON SWITCH Note: NUT, SWITCH	10	1
15	312751	LOCK WASHER Note: WASHER, LOCK	10	1
16	Y312702	KNURLED NUT Note: NUT, KNURLED	10	1
17	33002798	LAMP, PILOT Note: LAMP, INDICATOR	10	1
18	215564	LENS, INDICATOR (AMBER) Note: LENS, INDICATOR	10	1

BDSPARTS.COM

*Color Code (-)=Not Shown #=Series, Serial Prefix or Run No., N=Not Available

Section: CONTROL CENTER

Model: MDG16CSBWW

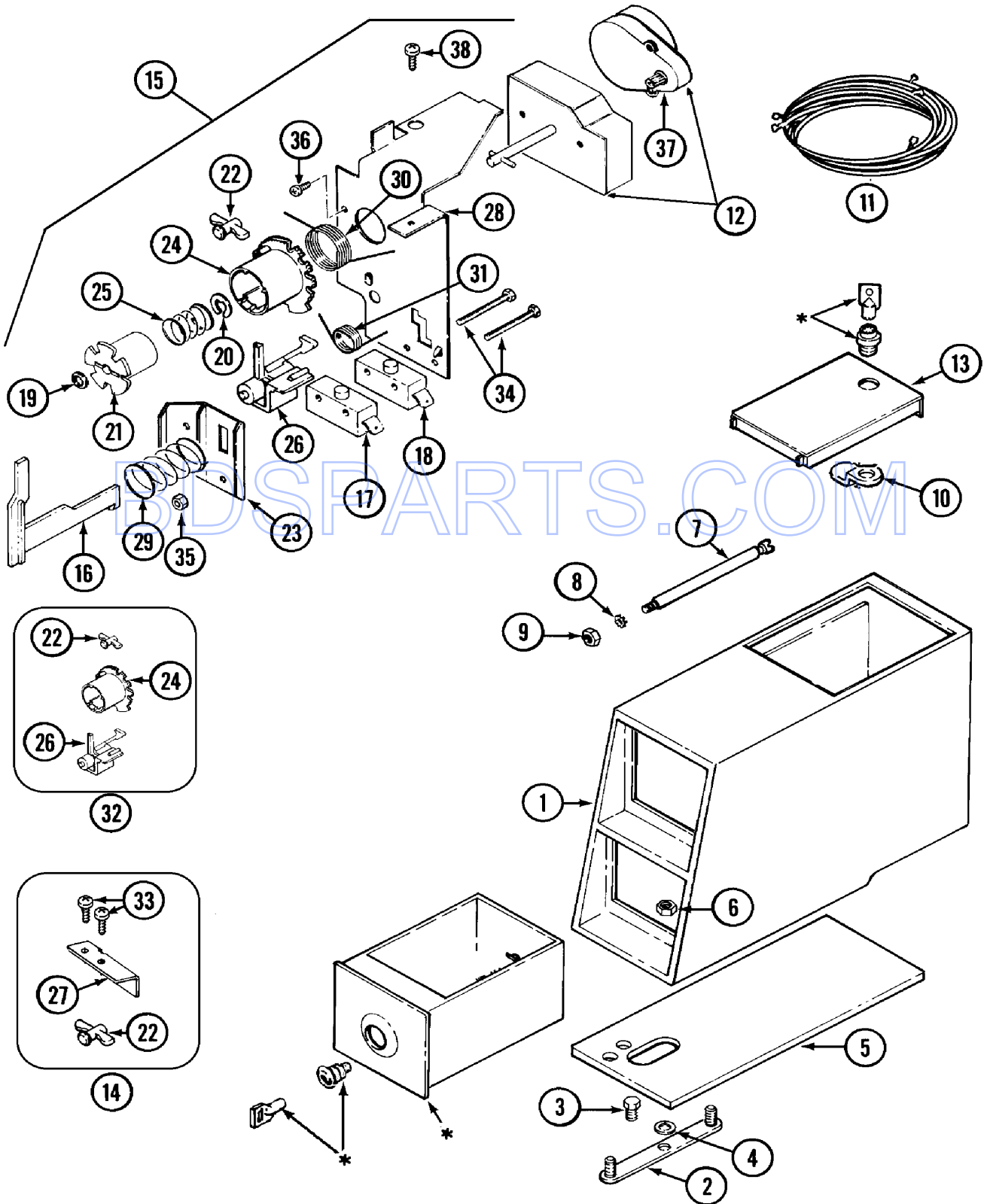

* CONTACT YOUR COMMERCIAL LAUNDRY DISTRIBUTOR

Section: CONTROL CENTER

No.	Part No.	Description	Series	Qty
1	22002478	VAULT, COIN (WHT)CS Note: VAULT, COIN (WHT)	10	1
2	22001810	STRAP, MOUNTING	10	1
3	22002925	SCREW Note: SCREW, MOUNTING STRAP	10	1
4	910309	WASHER Note: WASHER, STRAP SCREW	10	1
6	Y052740	NUT Note: NUT, CASE MOUNTING	10	1
7	22001903	LOCKING BOLT, COIN SLIDE Note: BOLT, LOCKING	10	1
8	910387	LOCK WASHER Note: LOCKWASHER, LOCKING BOLT	10	2
9	Y052721	NUT Note: NUT, LOCKING BOLT	10	2
10	22003677	LOCKING CAM	10	1
11	33001195	WIRE HARNESS, TIMER	10	1
12	33002115	TIMER	10	1
13	22003679	TIMER ACCESS DOOR ASSY (WHITE)	10	1
-	22001883	SCREW	10	1
-	22001881	GROMMET, DOUBLE	10	1
-	22001882	LATCH, ACCESS DOOR	10	1
14	33001688	ACTUATOR KIT, DRYER Note: ACTUATOR KIT	10	1
15	33001275	TORSION TIMER ASSY. Note: TORSION TIMER ASSEMBLY	10	1
16	314337	SLIDER	10	1
17	305798	BYPASS SWITCH FOR MOTOR Note: SWITCH, BY-PASS (MOTOR)	10	1
18	Y305799	BYPASS SWITCH FOR HEATER Note: SWITCH, BY-PASS (HEATER)	10	1
19	211790	LOCK RING FOR TIMER SHAFT Note: RETAINER, SPRING	10	1
20	312270	E CLIP Note: CLIP, SPRING RETAINER	10	1
21	314330	DRIVER FOR INDEX WHEEL Note: DRIVER, INDEX WHEEL	10	1
22	314335	TIME ADJUSTMENT PEG Note: PEG, TIME ADJUSTMENT	10	1
22	314547	ADJUSTMENT RETURN STOP Note: STOP, ADJUSTABLE RETURN	10	1
23	314339	SWITCH AND SLIDER BRACKET Note: BRACKET, SWITCH & SLIDER	10	1
24	314546	INDEX WHEEL Note: WHEEL, INDEX	10	1
25	211065	SPRING, TIMER KNOB Note: SPRING, INDEX WHEEL	10	1
26	314548	ACTUATOR, SWITCH Note: ACTUATOR, SWITCH	10	1
27	33001708	BRACKET, COIN SLIDE	10	1
28	33002702	TIMER BRACKET	10	1
29	314340	HELICAL SPRING Note: SPRING, HELICAL	10	1
30	314331	RETURN SPRING Note: SPRING, TORSION RETURN	10	1
31	314332	ACTUATOR SPRING Note: SPRING, ACTUATOR	10	1
32	306104	TORSION-TIMER KIT Note: ACTUATOR KIT	10	1
33	212707	SCREW Note: SCREW, SLIDE BRACKET	10	2
34	315277	SCREW Note: SCREW, BY-PASS SWITCHES	10	2
35	Y052634	HEX. NUT, #6-32 Note: NUT, BY-PASS SWITCHES	10	2
36	910708	SCREW -RELAY TO TUB SUPPORT Note: SCREW, TIMER	10	2
37	Y308991	MOTOR, TIMER	10	1
38	211168	SCREW, #8 X 5/16 INCH Note: SCREW, TIMER BRACKET	10	1

*Color Code (-)=Not Shown #=Series, Serial Prefix or Run No., N=Not Available

Section: CABINET-FRONT

Model: MDG16CSBWW

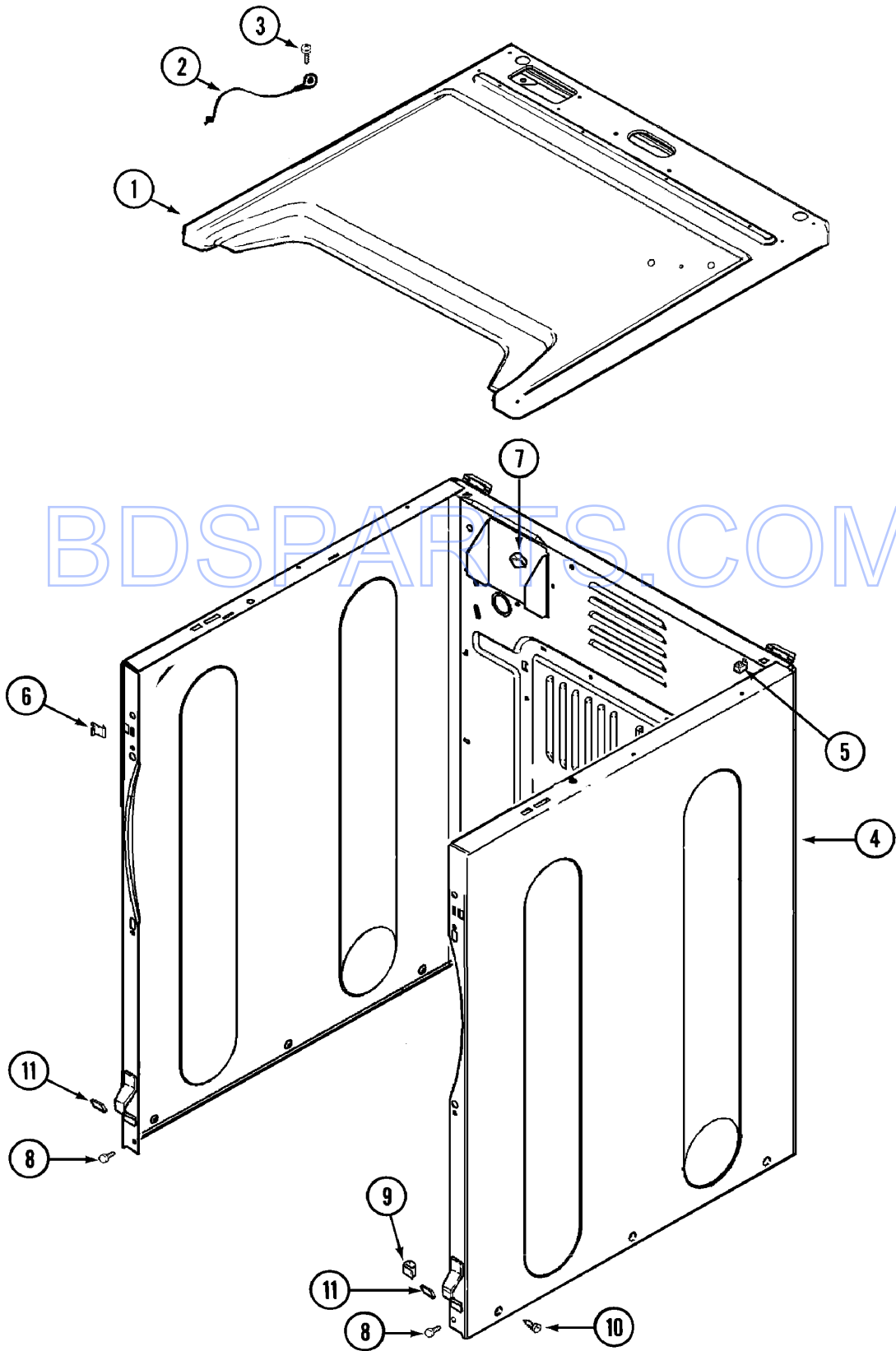

CD13-8

Section: CABINET-FRONT

No.	Part No.	Description	Series	Qty
1	33002633	COVER, TOP (WHT-AS PK)	10	1
2	22001959	WIRE, GROUND	10	1
3	210186	SCREW, GROUND WIRE TO BASE--NA Note: SCREW, GROUND WIRE	10	1
4	N 22003643	CABINET ASSY. (WHT AS PK)	10	1
5	213280	FRONT PANEL BRACKET/FASTENER	10	2
6	22002049	CLIP	10	2
7	22003298	RETAINER, WIRE	10	1
8	33002190	SCREW (#10-3/8")	10	2
9	310376	CLIP, WIRE HARNESS	10	1
10	213007	SCREW, CABINET	10	6
11	22002239	CLIP, LOWER FRONT PANEL	10	2

BDSPARTS.COM

*Color Code (-)=Not Shown #=Series, Serial Prefix or Run No., N=Not Available

Section: DOOR

Model: MDG16CSBWW

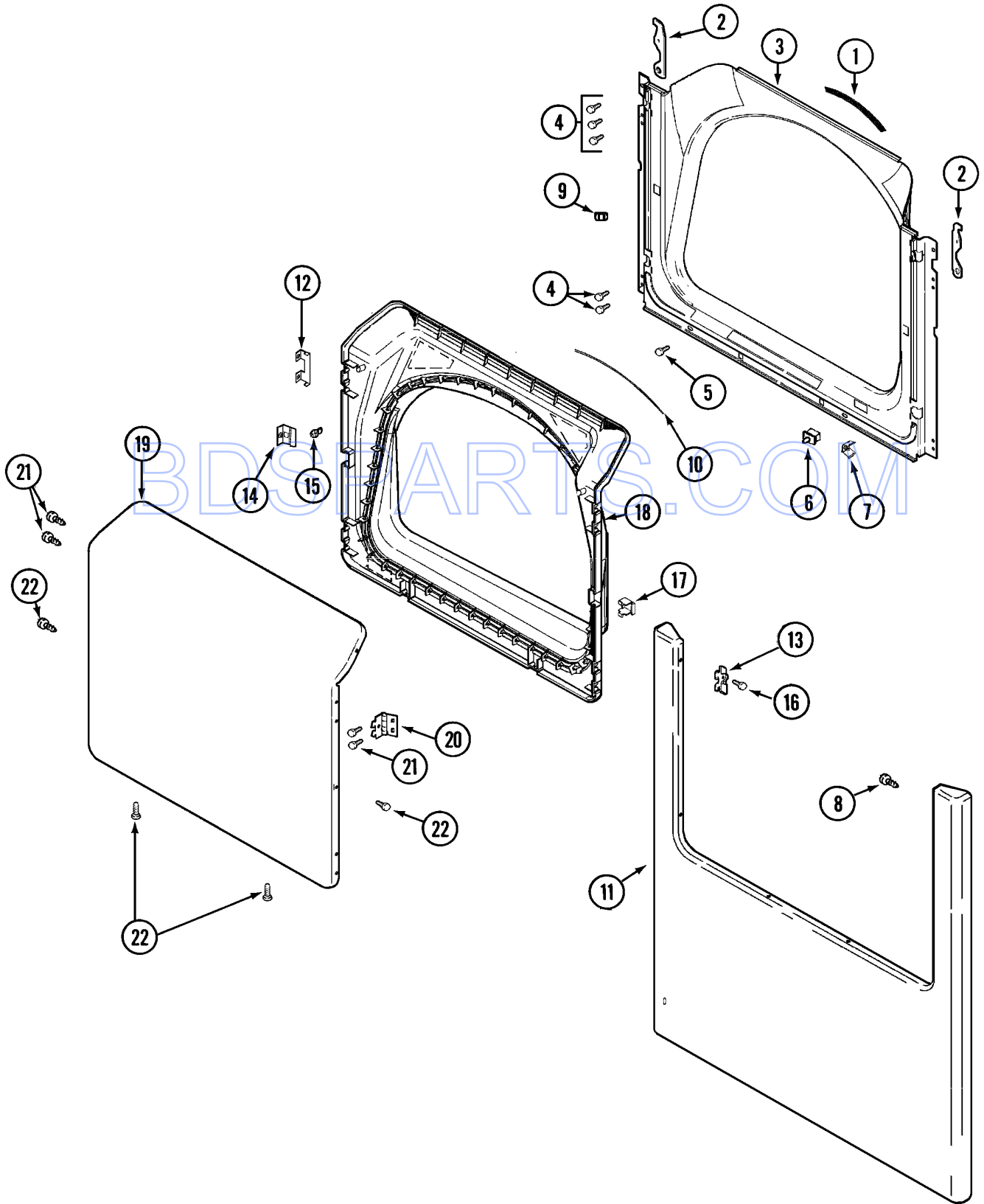

CD12-21

Section: DOOR

No.	Part No.	Description	Series	Qty
1	33001767	SEAL, SHROUD	10	1
2	33002597	HOOK, SECURITY	10	2
3	33001900	SHROUD (WHT)	10	1
4	22001995	SCREW Note: SCREW, TUMBLER FRONT & SHROUD	10	10
5	213280	FRONT PANEL BRACKET/FASTENER Note: SCREW, SHROUD & OUTLET DUCT	10	2
6	33001509	SWITCH, DOOR	10	1
7	33001760	BRACKET, HINGE	10	4
8	22002243	SCREW Note: SCREW, HINGE BRACKET	10	2
-	22002244	CLIP, GROUNDING	10	1
9	Y304578	CATCH, DOOR (FEMALE)	10	2
10	33002094	SEAL, DOOR	10	1
-	213280	FRONT PANEL BRACKET/FASTENER Note: FASTENER, FRONT PANEL	10	2
-	22002239	CLIP, LOWER FRONT PANEL	10	2
11	33001901	PANEL, FRONT (WHT)	10	1
12	22002038	CLIP, DOOR (DOUBLE)	10	4
13	33001764	COVER, HINGE HOLE (WHT)	10	2
14	33001793	BRACKET, STRIKE	10	1
15	33001761	STRIKE, DOOR (MALE)	10	1
16	33001846	SCREW Note: SCREW, HINGE HOLE COVER	10	2
17	33001763	PLUG, INNER DOOR	10	1
18	33001899	DOOR, INNER (WHT)	10	1
19	33001904	DOOR, OUTER (WHT) Note: DOOR, OUTER (WHT)	10	1
20	33001759	HINGE, DOOR	10	2
21	22002062	SCREW Note: SCREW, HINGE	10	4
22	22002063	SCREW #8-18AB WAFER HD	10	6

*Color Code (-)=Not Shown #=Series, Serial Prefix or Run No., N=Not Available

Section: CABINET-REAR

Model: MDG16CSBWW

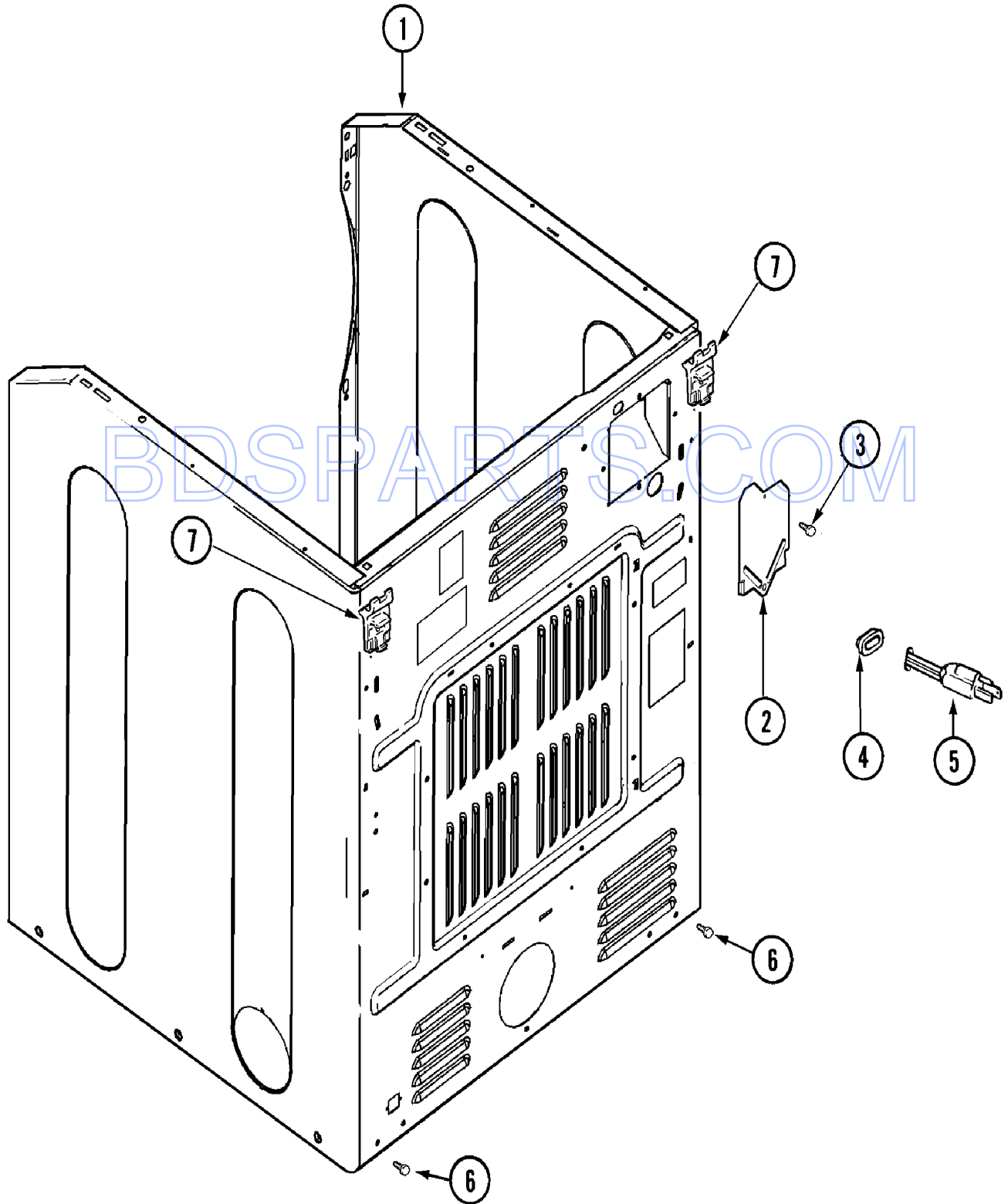

CD18-28

Section: CABINET-REAR

No.	Part No.	Description	Series	Qty
1	N 22003643	CABINET ASSY. (WHT AS PK)	10	1
2	33001795	COVER, TERMINAL BLOCK	10	1
3	22001995	SCREW Note: SCREW, TERMINAL BLOCK COVER	10	1
4	211881	GROMMET, CORD	10	1
5	33002776	POWER CORD	10	1
6	22001995	SCREW Note: SCREW, CABINET	10	2
7	22003367	HINGE, PLASTIC	10	2
-	22001995	SCREW Note: SCREW, HINGE	10	2

BDSPARTS.COM

*Color Code (-)=Not Shown #=Series, Serial Prefix or Run No., N=Not Available

Section: GAS VALVE

Model: MDG16CSBWW

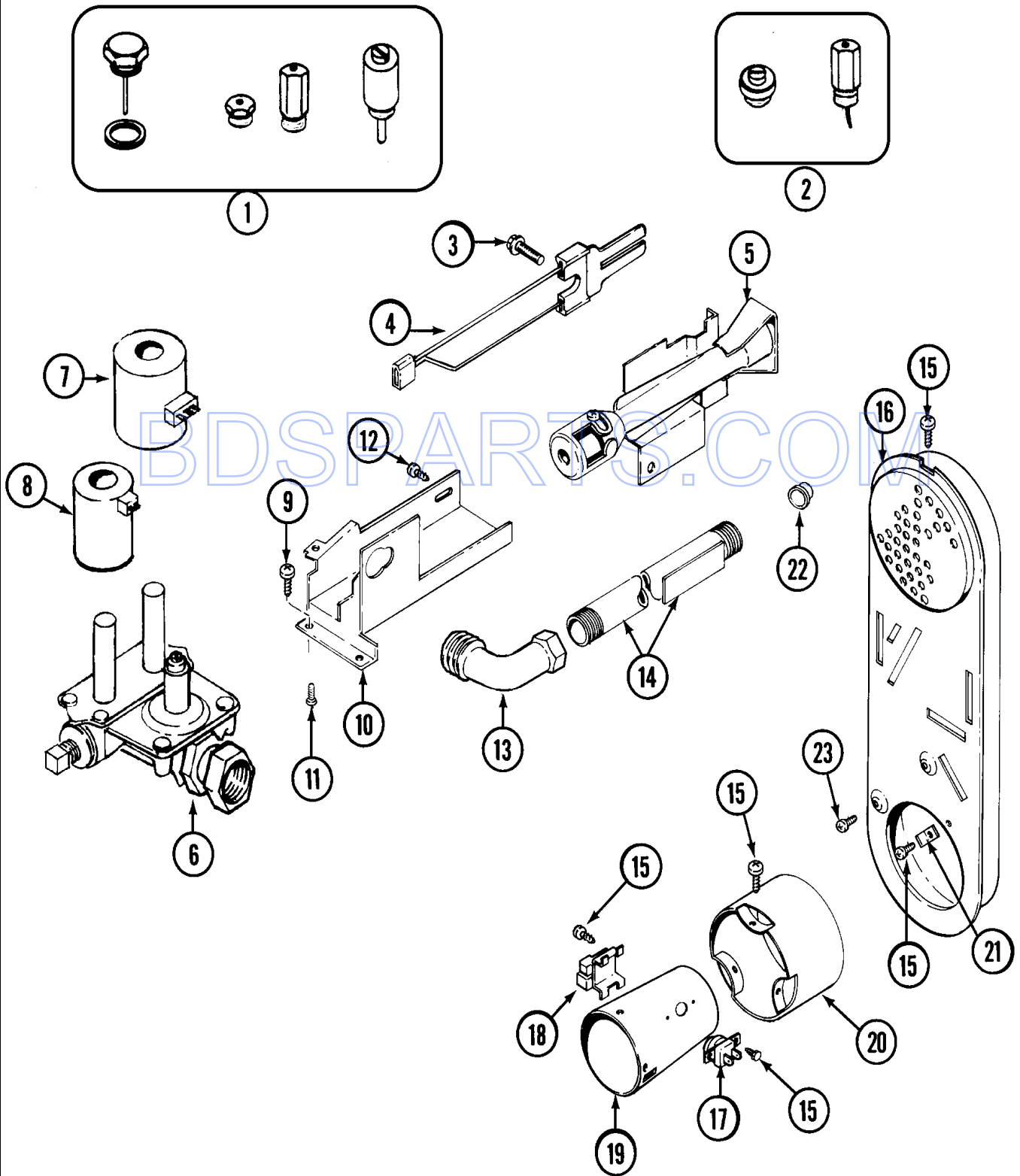

CD14-5

Section: GAS VALVE

No.	Part No.	Description	Series	Qty
1	308378	CONVERSION KIT (NATURAL TO LP)	10	1
2	Y308377	CONVERSION KIT (LP TO NATURAL)	10	1
3	304971	SCREW Note: SCREW, IGNITER	10	1
4	304970	IGNITER ASSY, GAS VALVE	10	1
-	33002789	IGNITER ASSEMBLY	15	1
5	33002706	ASSY, BURNER	10	1
6	308345	VALVE, GAS	10	1
7	306106	COIL, HOLDING & BOOSTER	10	1
8	306105	COIL, SECONDARY	10	1
9	N 33002709	SCREW, #8 X 3/8 HEX Note: SCREW, GAS VALVE	10	2
10	33002710	BRACKET, GAS CONTROL	10	1
11	314568	SCREW-GAS VALVE TO BRACKET Note: SCREW, GAS VALVE	10	1
12	310632	SCREW Note: SCREW, GAS VALVE	10	1
13	33001842	CONNECTOR, ANGLE	10	1
14	33001735	PIPE & BRACKET ASSY.	10	1
15	211294	SCREW Note: SCREW, DUCT	10	7
16	33001810	DUCT ASSY., INLET (GAS) Note: INLET DUCT ASSEMBLY	10	1
17	305169	THERMOSTAT, HI-LIMIT GAS	10	1
18	303377	SENSOR, RADIANT	10	1
19	33001835	CONE ASSY., COMBUSTION	10	1
20	Y303841	CONE, EXTENSION (COMBUSTION)	10	1
21	Y312890	RETAINER, HEATER CHAMBER	10	1
22	33001693	CAP, GAS PIPE	10	1
23	22001996	SCREW Note: SCREW, DUCT	10	4

*Color Code (-)=Not Shown #=Series, Serial Prefix or Run No., N=Not Available

Section: MOTOR DRIVE

Model: MDG16CSBWW

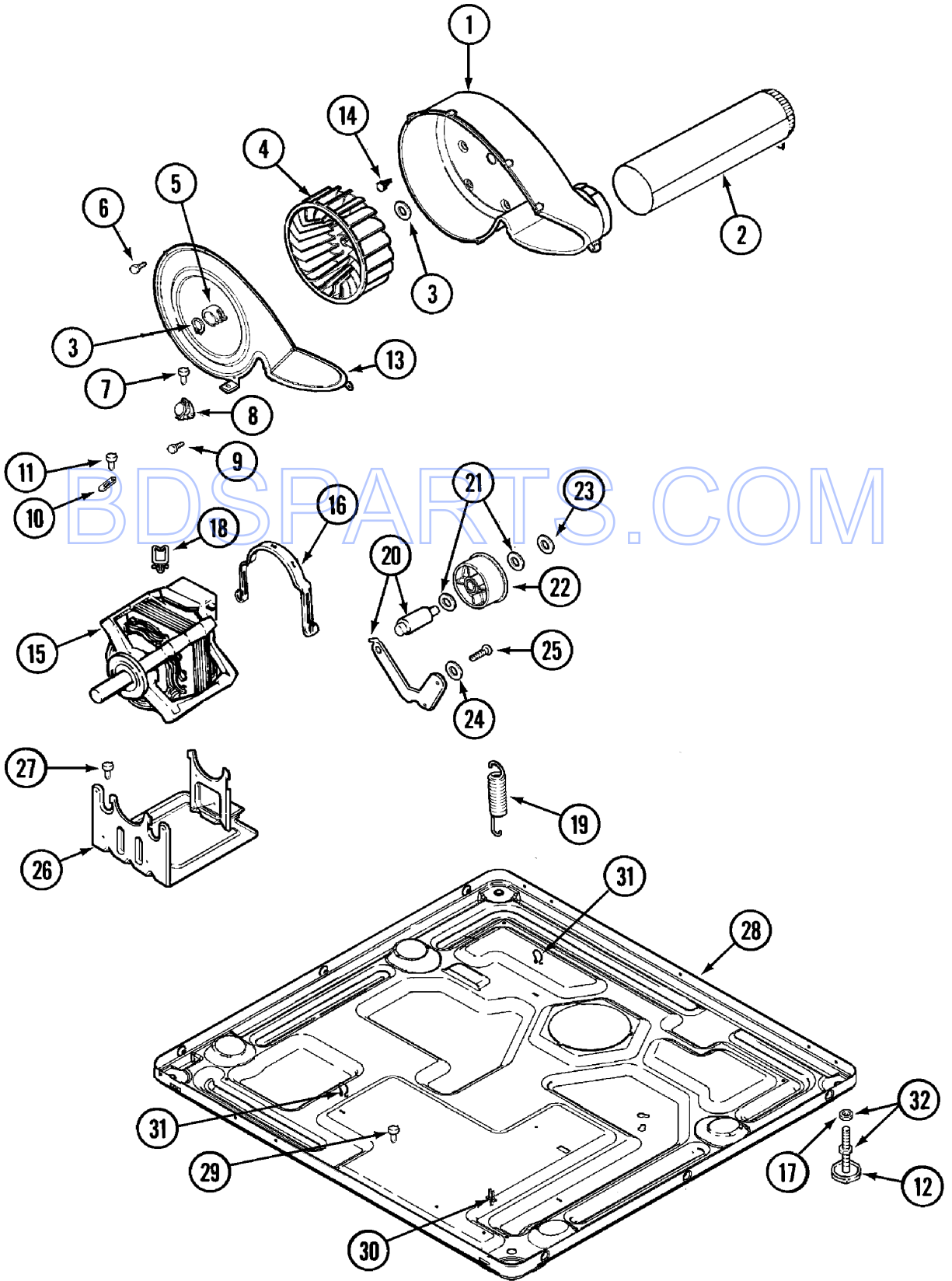

CD17-28

Section: MOTOR DRIVE

No.	Part No.	Description	Series	Qty
1	33001789	HOUSING, BLOWER	10	1
-	33002190	SCREW (#10-3/8") Note: SCREW, EXHAUST DUCT ASSEMBLY	10	1
2	33001799	OUTLET DUCT ASSEMBLY	10	1
3	410233	RING, RETAINING	10	2
4	33001790	WHEEL, BLOWER	10	1
4	33002797	WHEEL, BLOWER	23	1
5	312967	CLAMP, BLOWER HOUSING	10	1
6	33001855	SCREW (HEX HEAD) Note: SCREW, HOUSING COVER	10	8
7	N 313561	SCREW----NA Note: SCREW, HOUSING COVER	10	3
8	306966	THERMOSTAT, MULTI-TEMP Note: THERMOSTAT, MULTI-TEMP.	10	1
8	303392	CYCLING THERMOSTAT 140 DEG. Note: THERMOSTAT, CYCLING	10	1
9	22002925	SCREW Note: SCREW, THERMOSTAT	10	4
10	33001762	FUSE, THERMAL (W' BRACKET)	10	1
11	314848	SCREW Note: SCREW, THERMAL CUT-OFF	10	1
12	314137	FOOT, RUBBER	10	4
13	33002711	COVER, BLOWER HOUSING	10	1
14	310632	SCREW Note: SCREW, BLOWER HOUSING	10	4
15	33002478	MOTOR	10	1
15	33002795	MOTOR, DRIVE 60HZ	23	1
16	Y015825	CLIP, MOTOR	10	2
17	Y052740	NUT Note: NUT, LEG	10	4
18	310376	CLIP, WIRE HARNESS	10	1
-	33002157	GROMMET	10	1
19	33002459	ASSEMBLY, SPRING & PLUG	10	1
-	33002461	PLUG FOR SPRING	10	1
19	33002460	SPRING, IDLER	10	1
20	33001840	IDLER ARM & SHAFT ASSY.	10	1
21	312527	WASHER, IDLER SHAFT (QTY-1)	10	2
22	33001783	BEARING, IDLER ASSEMBLY	10	1
23	312958	RETAINING RING, IDLER SHAFT	10	1
24	315772	SLEEVE, IDLER ARM	10	1
25	Y014874	SCREW Note: SCREW, IDLER ARM SLEEVE	10	1
-	N 313561	SCREW----NA Note: SCREW, SUPPORT	10	1
26	33002466	SUPPORT, MOTOR	10	1
27	N 313561	SCREW----NA Note: SCREW, MOTOR & BLOWER	10	2
28	N 33002465	BASE, (LWR)----NA	10	1
29	22001078	SCREW Note: SCREW, RELAY & BASE	10	2
30	315471	RETAINER, WIRE	10	1
31	410490	SPRING, WIRE HARNESS	10	2

*Color Code (-)=Not Shown #=Series, Serial Prefix or Run No., N=Not Available

Section: TUMBLER

Model: MDG16CSBWW

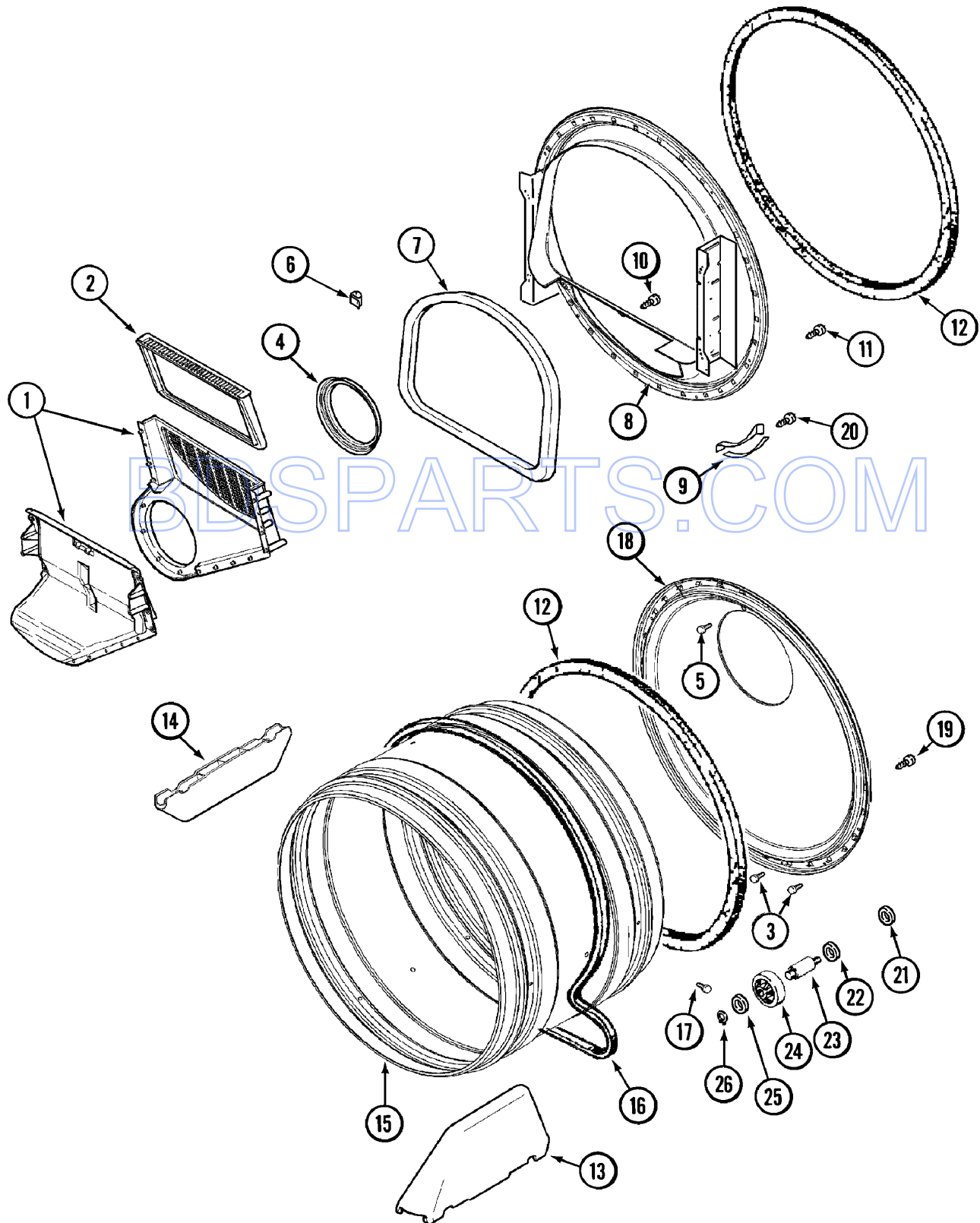

CD16-29

Section: TUMBLER

No.	Part No.	Description	Series	Qty
1	33001799	OUTLET DUCT ASSEMBLY	10	1
2	33001804	FILTER, LINT	10	1
3	22001996	SCREW Note: SCREW, INLET DUCT	10	2
4	33002560	SEAL, BLOWER	10	1
5	210932	SCREW, #8 X 9/16 CTSK Note: SCREW, INLET DUCT	10	1
6	310376	CLIP, WIRE HARNESS	10	1
7	33001767	SEAL, SHROUD	10	1
8	33001802	FRONT, TUMBLER (W/SEAL)	10	1
9	306508	TUMBLER BEARING KIT	10	2
10	N 312311	SCREW----NA Note: SCREW, OUTLET DUCT (PHILLIPS)	10	1
11	33001855	SCREW (HEX HEAD) Note: SCREW, DUCT TO TUMBLER (HEX)	10	4
12	33001807	SEAL, TUMBLER	10	2
13	33001756	BAFFLE (TALL)	10	2
14	33001755	BAFFLE (SHORT)	10	1
15	33001794	TUMBLER	10	1
16	33002535	V-BELT (TUMBLER)	10	1
17	33001788	SCREW, BAFFLE	10	6
18	33001801	BACK, TUMBLER (W/SEAL)	10	1
19	33002190	SCREW (#10-3/8")	10	4
20	210720	RIVET	10	4
21	33001443	NUT, HEX (ROLLER SHAFT)	10	2
22	Y313347	WASHER, SPRING (ROLLER SHAFT)	10	2
23	312948	SHAFT, TUMBLER ROLLER	10	2
24	Y303373	BEARING & ROLLER ASSEMBLY Note: ROLLER (W/BEARING)	10	2
25	312535	WASHER, ROLLER SHAFT	10	2
26	410233	RING, RETAINING	10	2

*Color Code (-)=Not Shown #=Series, Serial Prefix or Run No., N=Not Available

Section: SUPPLEMENT INFORMATION

Model: MDG16CSBWW

No image available

BDSPARTS.COM

NOIMAGE

Section: SUPPLEMENT INFORMATION

No.	Part No.	Description	Series	Qty
-	33001195	WIRE HARNESS, TIMER	10	1
-	33002598	ACTUATOR, DRYER KIT	10	1
-	33002244	WIRE HARNESS, MAIN	10	1

BDSPARTS.COM

*Color Code (-)=Not Shown #=Series, Serial Prefix or Run No., N=Not Available

Section: WIRING INFORMATION

Model: MDG16CSBW

TIMER INFORMATION			66.7 MIN	
CAM NO.	CIRCUIT	FUNCTION		
①	Y-BK/RD	MOTOR	6.7 MIN	
<input type="checkbox"/> CAM OPEN <input checked="" type="checkbox"/> CAM CLOSED <input checked="" type="checkbox"/> CAM MAY BE OPEN OR CLOSED	HEATER & MOTOR BY-PASS SWITCHES	SETTING	4.6 MIN	
		33 MIN		
		40 MIN		
		47 MIN		
		53 MIN		
		60 MIN		

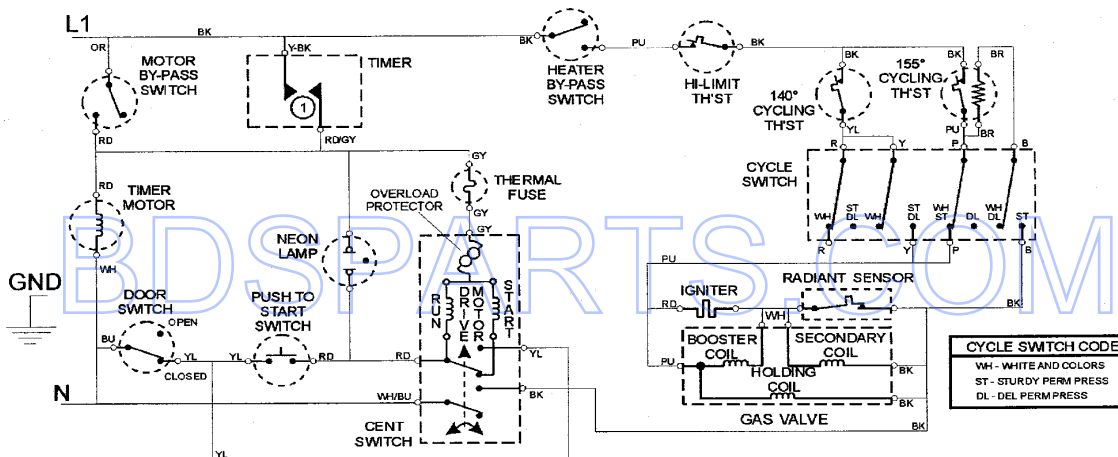

"CAUTION: Label all wires prior to disconnection when servicing controls. Wiring errors can cause improper and dangerous operation."

"Verify proper operation after servicing."

ELECTRICAL SCHEMATIC

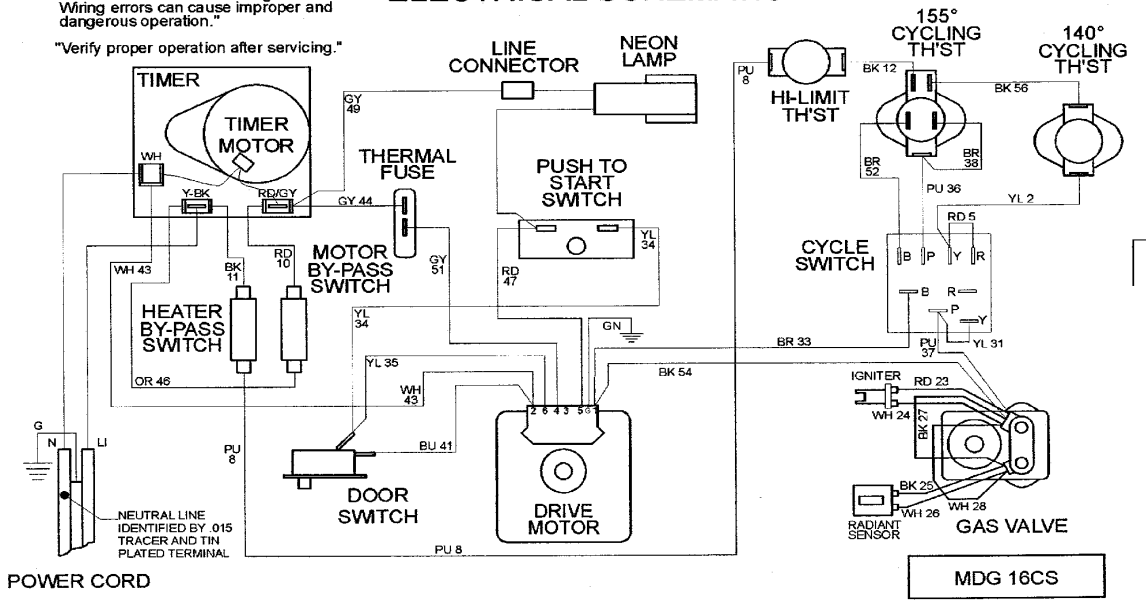

ELECTRICAL WIRING DIAGRAM

15003115

