

DRYER

Repair Parts List

MODEL NUMBER

MDG170P1HW

BDSPARTS.COM

When requesting service or ordering parts, always provide the following information:

- Product Type
- Part Number
- Model Number
- Part Description

MAYTAG®

©2005 Maytag Services

Section: CONTROL DOOR ASSEMBLY

Model: MDG170P1HW

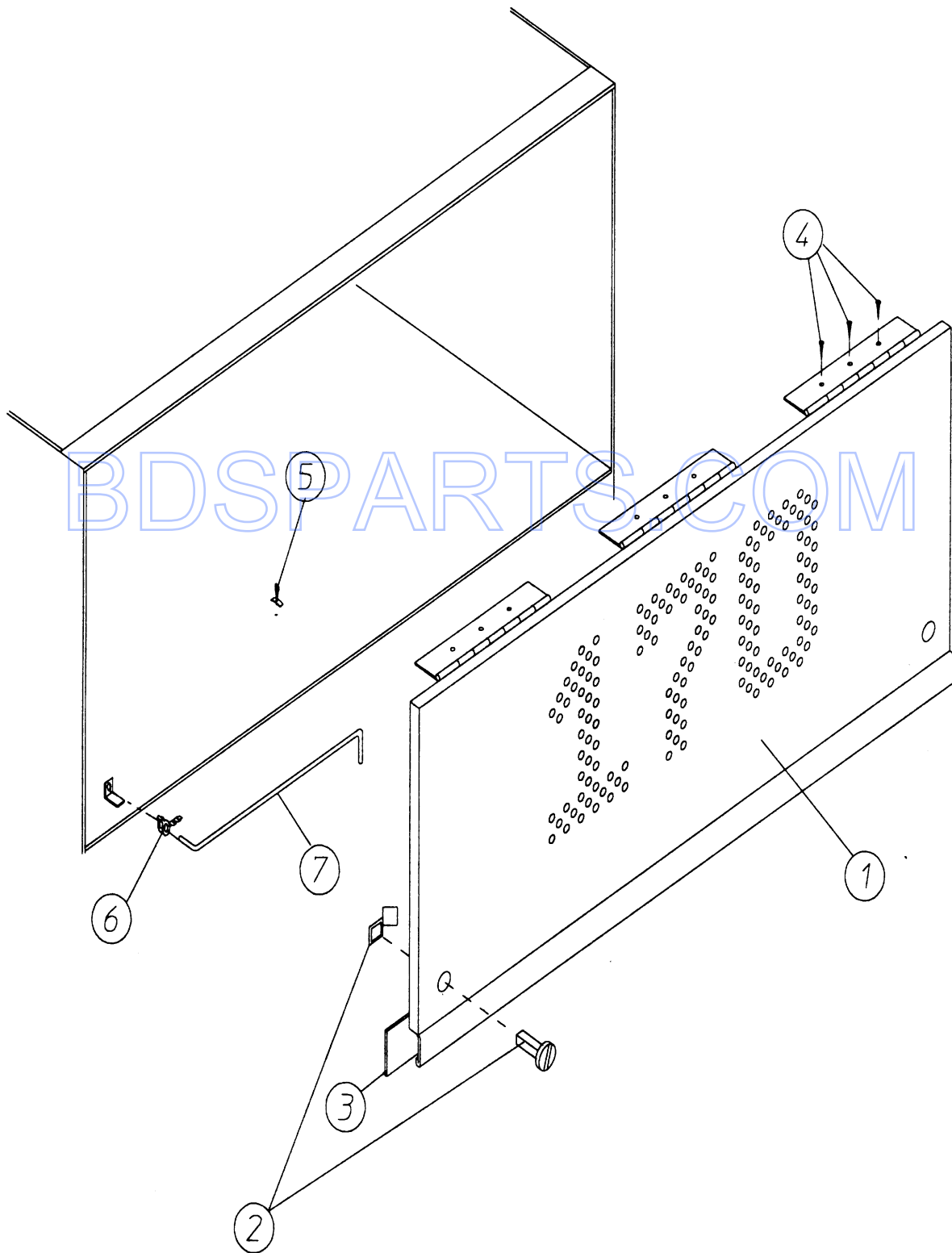

Section: CONTROL DOOR ASSEMBLY

No.	Part No.	Description	Series	Qty
-	-----	NOT REQUIRED PART OR SEE NOTE Note: ORDER PARTS FROM AMERICAN DRYER CORP AT 508-678-9000.		0
1	A820944	DOOR ASSY Note: (SPECIFY COLOR WHEN ORDERING)		1
2	A882541	LATCH, SPRING TURN (2-PIECE)		2
3	A117600	GASKET, TAPE (SOLD IN FEET)		5
4	A150309	SCREW, CRIMPTITE Note: SCREW, CRIMPTITE (PH. RD.HD.) (#10-16 X 1/2")		9
5	A102600	CATCH, ROD SUPPORT-CTRL. DOOR Note: CATCH, ROD SUPPORT-CNTL. DOOR		1
6	A102601	CLIP, ROD RETAINER-CTRL. DOOR		1
7	A102505	ROD, SUPPORT-CTRL. DOOR Note: ROD, SUPPORT-CTRL. DOOR		1

BDSPARTS.COM

*Color Code (-)=Not Shown #=Series, Serial Prefix or Run No., N=Not Available

Section: CONTROL PANEL ASSEMBLY (MICROPROCESSOR)

Model: MDG170P1HW

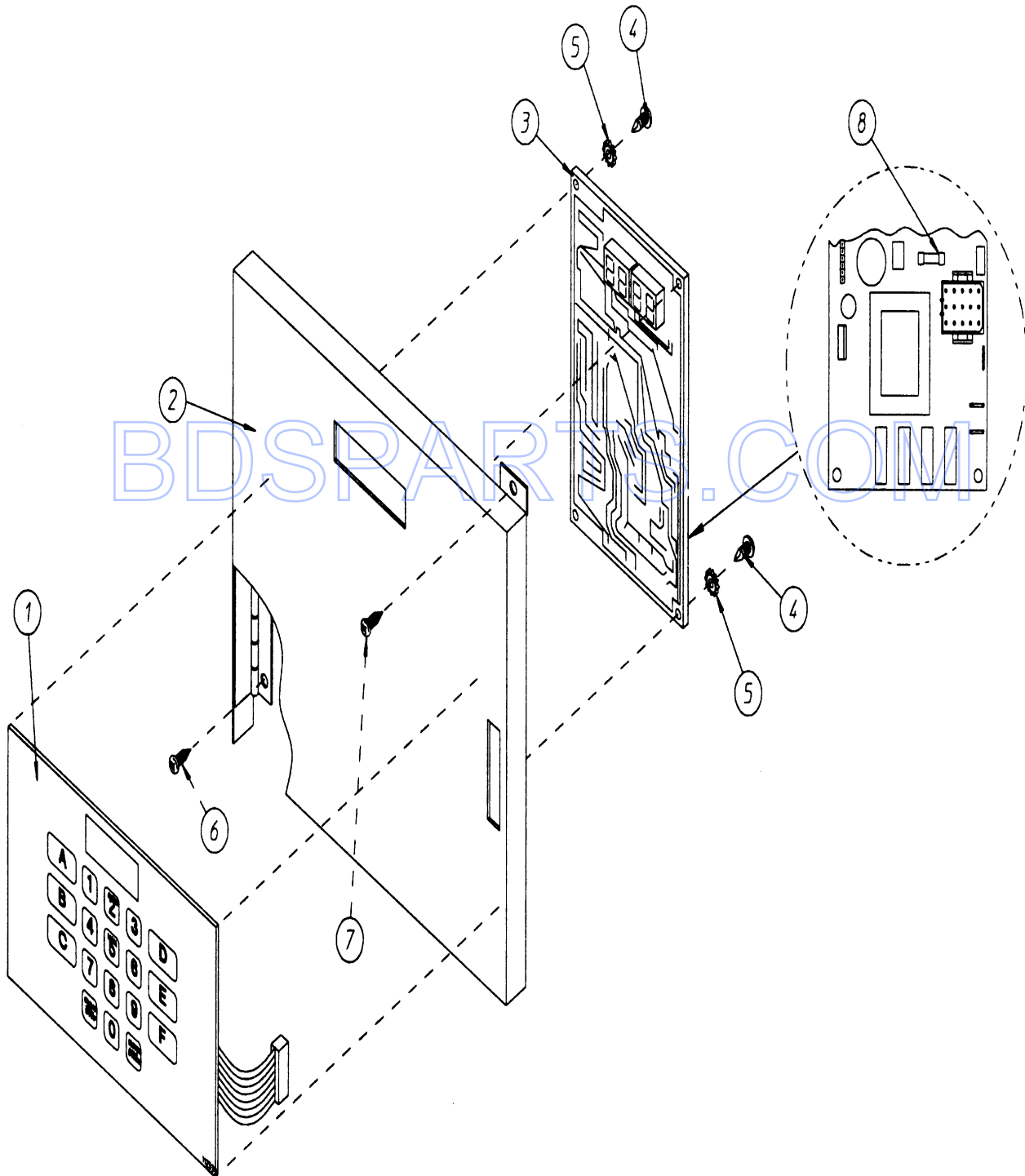

Section: CONTROL PANEL ASSEMBLY (MICROPROC

No.	Part No.	Description	Series	Qty
-	-----	NOT REQUIRED PART OR SEE NOTE Note: ORDER PARTS FROM AMERICAN DRYER CORP AT 508-678-9000.		0
1	A112277	LABELS, STICK-ON (3-LANGUAGE) Note: LABELS, STICK-ON (3-LANGUAGE) (ENGLISH, SPANISH AND HEBREW)		1
1	A112535	LABEL ASSY., KEYBOARD Note: LABEL ASSY., KEYBOARD (ENGLISH)		1
1	A112278	LABELS, STICK-ON (5-LANGUAGE) Note: LABELS, STICK-ON (5-LANGUAGE) (ITALIAN, DUTCH, FRENCH, GERMAN AND CHINESE)		1
1	A112276	LABELS, STICK-ON Note: LABELS, STICK-ON (ENGLISH ONLY)		1
1	A112275	LABELS, STICK-ON Note: LABELS, STICK-ON (SPANISH, ITALIAN AND HEBREW)		1
2	A821101	DOOR ONLY (COMPUTER)		1
2	A821102	DOOR, COMPUTER W/BATTERY BRKT.		1
2	A881055	DOOR COMPLETE W/BATTERY OPT. Note: DOOR COMPLETE W/BATTERY OPT.		1
2	A821024	DOOR COMPLETE (COMPUTER) Note: (INCLUDES 1 - 8 SPECIFY COLOR WHEN ORDERING)		1
3	A137225	CONTROLLER, MICROPROCESSOR Note: (REVERSING W/AIR JET)		1
4	A150005	SCREW, PHILL (6-32 X 1/4")RND Note: SCREW, PHILLIPS RD. HD. (6-32 X 1/4")		2
5	A153010	WASHER, STAR (#6) Note: WASHER, STAR (#6)		2
6	A150000	SCREW, MACHINE (RD.HD. SLOT) Note: SCREW, MACHINE (RD.HD. SLOT) (6-32 X 1/4")		3
7	A150309	SCREW, CRIMPTITE Note: SCREW, PHILLIPS (RD. HD.) (#10-16 X 1/2")		1
8	A136048	FUSE, 1/8 AMP (SLO BLO)		1
-	-----	NOT REQUIRED PART OR SEE NOTE Note: -----NOTE----- (IMPORTANT: CHECK LABEL ON COMPUTER CHIP TO VERIFY CORRECT PART NUMBER)		1

BDSPARTS.COM

*Color Code (-)=Not Shown #=Series, Serial Prefix or Run No., N=Not Available

Section: CONTROL BOX ASSEMBLY

Model: MDG170P1HW

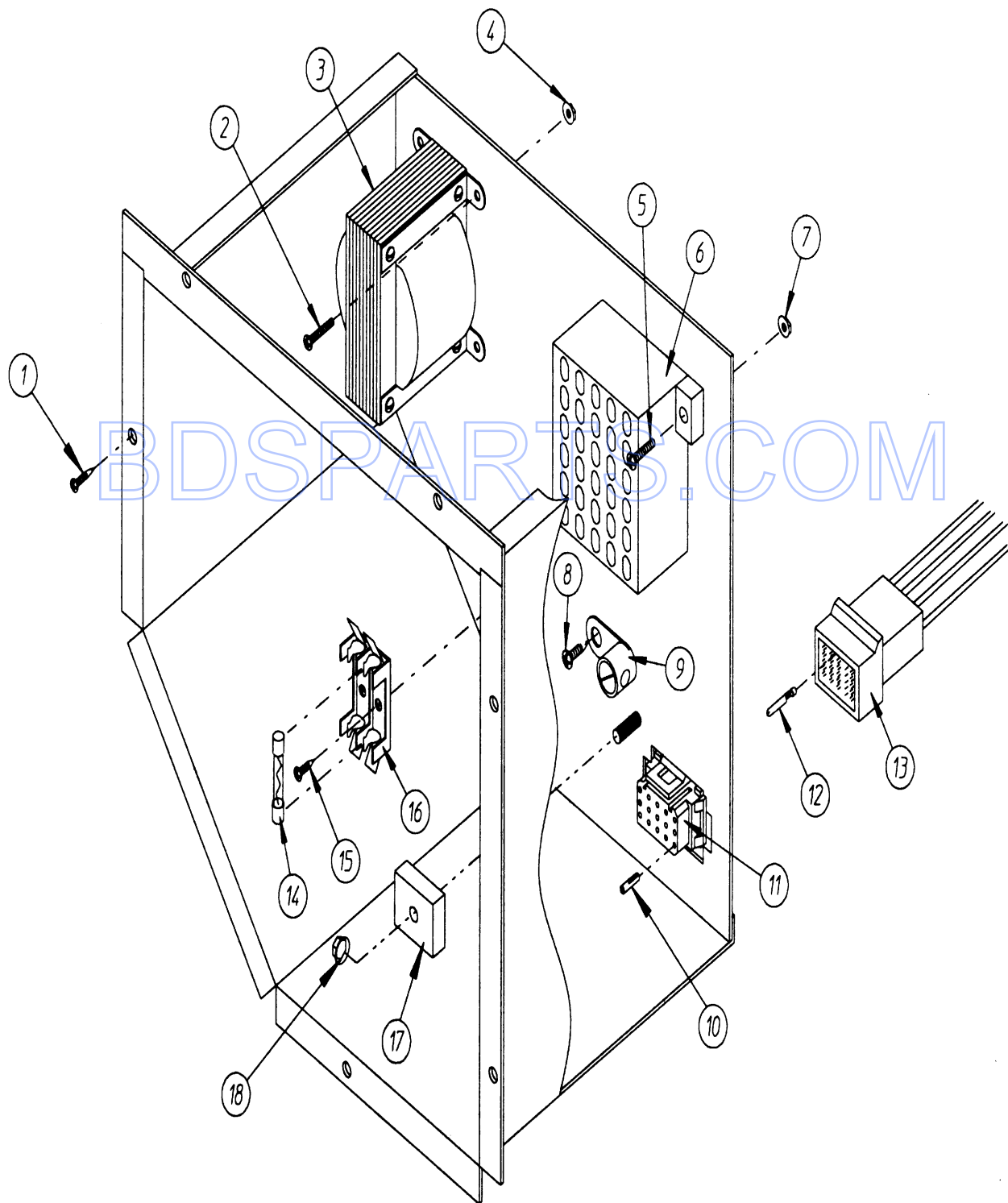

Section: CONTROL BOX ASSEMBLY

No.	Part No.	Description	Series Qty
-	-----	NOT REQUIRED PART OR SEE NOTE Note: ORDER PARTS FROM AMERICAN DRYER CORP AT 508-678-9000.	0
1	A150301	SCREW, TEK (#8-18 X 7/16 PH Note: SCREW, TEK (#8-18 X 7/16" PH.PN.HD.)	6
2	A150100	SCREW, MACHINE (RD.HD.) Note: SCREW, MACHINE (RD.HD.) (#8-32 X 1/2")	2
3	A141403	TRANSFORMER (DSI 24 VAC) Note: TRANSFORMER (24 VAC) (FOR MICROPROCESSOR MODELS ONLY)	1
4	A151001	NUT, PAL (#8-32)	2
5	A150002	SCREW, MACHINE (RD.HD.) Note: SCREW, MACHINE (RD.HD.) (#6-32 X 1")	2
6	A120715	BLOCK, TERMINAL (30-POSITION)	1
7	A151000	PAL NUT (#6-32)	2
8	A150415	SCREW, CRIMPTITE (PH. RD.HD.) Note: SCREW, CRIMPTITE (PH.RD.HD.) (#10-16 X 1/2")	1
9	A121010	LUG, GROUND (L-70) Note: LUG, GROUND (L-70)	1
11	A122626	CONNECTOR, SOCKET (15-PIN) Note: CONNECTOR, SOCKET (15-PIN...ONLY)	1
13	A122625	CONNECTOR (15 PIN...ONLY) Note: CONNECTOR (15 PIN...ONLY)	1
14	A136057	FUSE, 1/2-AMP SLO-BLO Note: FUSE, 1/2-AMP (SLO-BLO...ONLY)	2
15	A150301	SCREW, TEK (#8-18 X 7/16 PH Note: SCREW, TEK (PH.PN.HD.) (#8-18 X 7/16")	2
16	A136008	STRIP, FUSE BLOCK (ONLY) Note: STRIP, FUSE BLOCK (ONLY)	2
17	-----	NOT REQUIRED PART OR SEE NOTE	0
18	A151000	PAL NUT (#6-32)	1
-	A122800	TOOL, EXTRACTION Note: TOOL, EXTRACTION (MICROPROCESSOR, FEMALE)	1
-	A122801	TOOL, EXTRACTION (PIN/SOCKET) Note: TOOL, EXTRACTION (PIN/SOCKET)	1

BDSPARTS.COM

*Color Code (-)=Not Shown #=Series, Serial Prefix or Run No., N=Not Available

Section: FRONT PANEL/MAIN DOOR ASSEMBLY

Model: MDG170P1HW

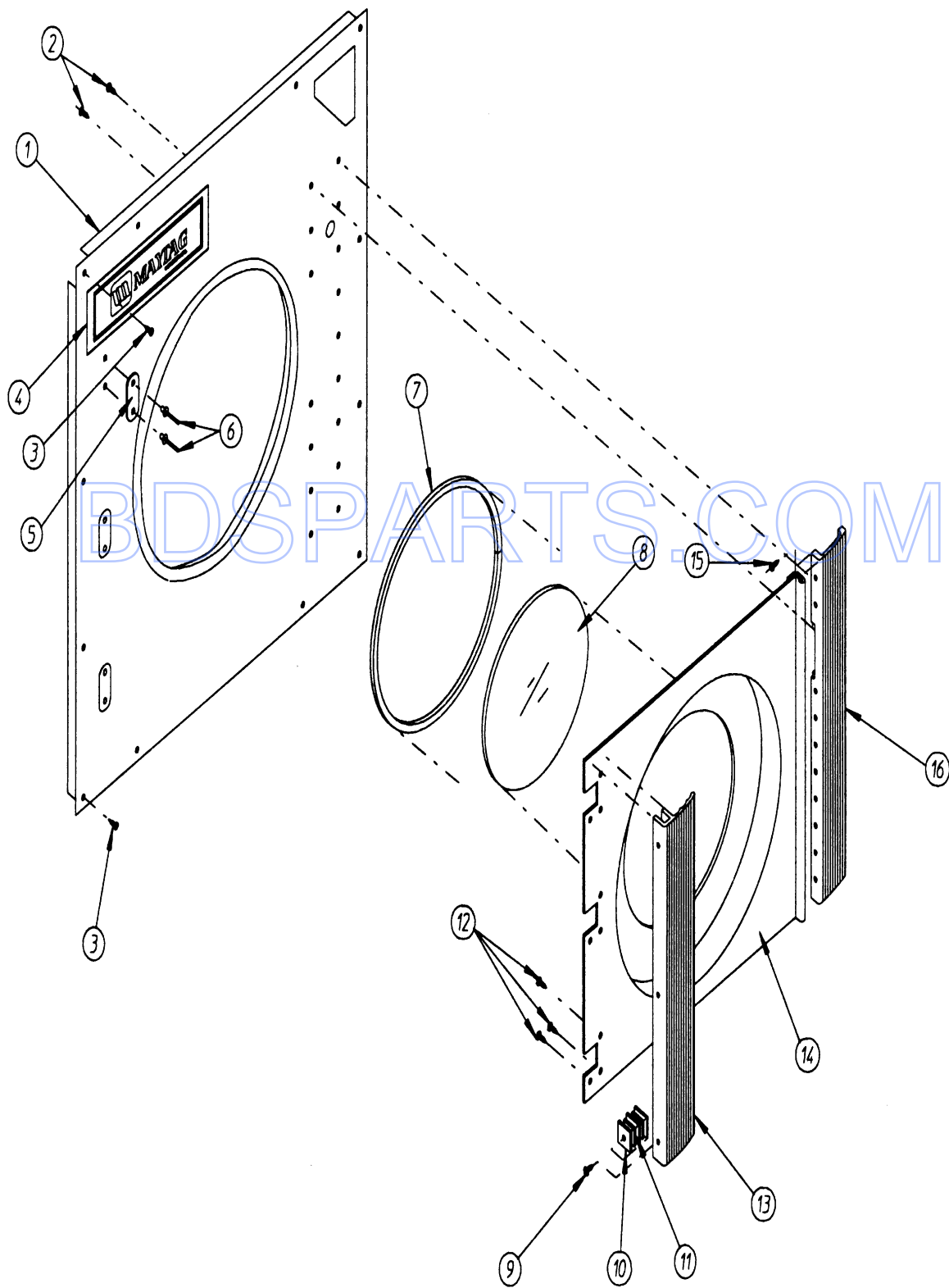

CD21-31

Section: FRONT PANEL/MAIN DOOR ASSEMBLY

No.	Part No.	Description	Series	Qty
-	-----	NOT REQUIRED PART OR SEE NOTE Note: ORDER PARTS FROM AMERICAN DRYER CORP AT 508-678-9000.		0
1	A820929	PANEL ASSY. (RT. HD. FRT.) Note: (INCLUDES 1, 5 AND 6..SPECIFY COLOR WHEN ORDERING)		1
2	A150415	SCREW, CRIMPTITE (PH. RD.HD.) Note: SCREW, CRIMPTITE (PH.RD.HD.) (#10-16 X 1/2")		15
3	A150412	SCREW, CRIMPTITE (PH.RD.HD.) Note: SCREW, CRIMPTITE (PH.RD.HD.) (#10-16 X 3/4")		12
4	A112360	LOGO Note: (LOGO TAPE KIT NOT INCLUDED AND MUST BE ORDERED SEPERATELY)		1
4	A870011	TAPE KIT (DOUBLE SIDED) Note: TAPE KIT (LOGO)		1
5	A170340	PAD, STRIKER (S.S. 3-1/2")		3
6	A154200	POP RIVET (5/32")		6
7	A102308	GASKET, DOOR (94" LNGT. ONLY) Note: GASKET, DOOR (94" LNGT. ONLY)		1
8	A170730	ADHESIVE, DOOR GLASS (10.3 OZ) Note: ADHESIVE, DOOR GLASS (10.3 OZ. CARTRIDGE)		1
8	A102210	GLASS, DOOR (20-7/16" ONLY) Note: GLASS, DOOR (20-7/16" ONLY)		1
9	A150401	SCREW, TAPTITE (PH.) Note: SCREW, TAPTITE (PH.) (#10-24 X 1-1/4")		3
10	A306801	KEEPER, MAGNET (ONLY) Note: KEEPER, MAGNET (ONLY)		6
11	A102102	MAGNETIC, MAIN DOOR Note: MAGNETIC, MAIN DOOR (1.0 X .750 X .215)		6
12	A150309	SCREW, CRIMPTITE Note: SCREW, CRIMPTITE (PH.RD.HD.) (#10-16 X 1/2")		9
13	A180150	HANDLE, DOOR (GRY-35" ONLY) Note: HANDLE, DOOR (GRY-35" ONLY)		1
14	A800128	DOOR ASSY. W/GRAY HANDLE Note: DOOR ASSY. W/GRAY HANDLE (INCLUDES 7 - 14)		1
14	A800125	DOOR ASSY. W/GLSS & GSKT ONLY Note: DOOR ASSY. W/GLSS & GSKT ONLY (INCLUDES 7, 8 AND 14)		1
14	A800265	DOOR ASSY. W/GRAY HANDLE Note: (INCLUDES 7 - 14, SPECIFY COLOR WHEN ORDERING)		1
14	A800122	DOOR ASSY. W/GLASS & GASKET Note: DOOR ASSY. W/GLASS & GASKET (INCLUDES 7, 8 AND 14, SPECIFY COLOR WHEN ORDERING)		1
15	A150430	SCREW, SELF DRILLING (PH) Note: SCREW, SELF DRILLING (PH) (#10 X 1/2")		11
16	A180155	BLOCK, DOOR HINGE (ONLY) Note: BLOCK, DOOR HINGE (ONLY) (35" GRAY)		1

*Color Code (-)=Not Shown #=Series, Serial Prefix or Run No., N=Not Available

Section: MAIN DOOR SWITCH ASSEMBLY

Model: MDG170P1HW

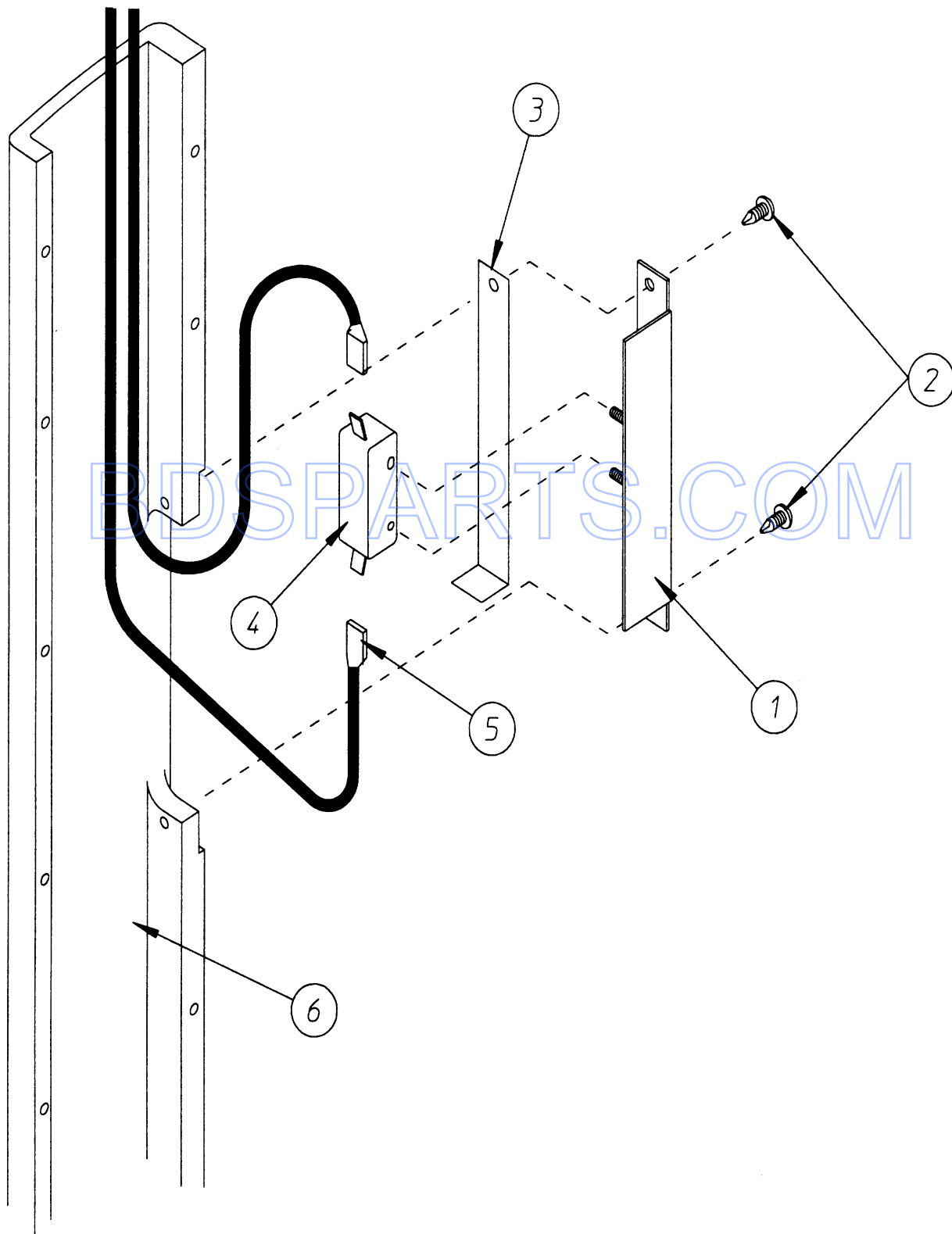

CD21-30

Section: MAIN DOOR SWITCH ASSEMBLY

No.	Part No.	Description	Series	Qty
-	-----	NOT REQUIRED PART OR SEE NOTE Note: ORDER PARTS FROM AMERICAN DRYER CORP AT 508-678-9000.		0
1	A821097	BRACKET, SWITCH ASSY. Note: BRACKET, SWITCH ASSY.		1
2	A150415	SCREW, CRIMPTITE (PH. RD.HD.) Note: SCREW, CRIMPTITE (PH.RD.HD.) (#10-16 X 1/2")		2
3	A102405	ACTUATOR, DOOR SWITCH		1
4	A137005	SWITCH, DOOR (SINGLE POLE) Note: SWITCH, DOOR (ONLY)		1
5	A121028	TERMINAL, 1/4" INSUL. (FEMALE) Note: TERMINAL, INSULATED (1/4" X .032)		2
6	A180155	BLOCK, DOOR HINGE (ONLY) Note: BLOCK, DOOR HINGE (ONLY) (35" GRAY)		1

BDSPARTS.COM

*Color Code (-)=Not Shown #=Series, Serial Prefix or Run No., N=Not Available

Section: LINT DOOR ASSEMBLY

Model: MDG170P1HW

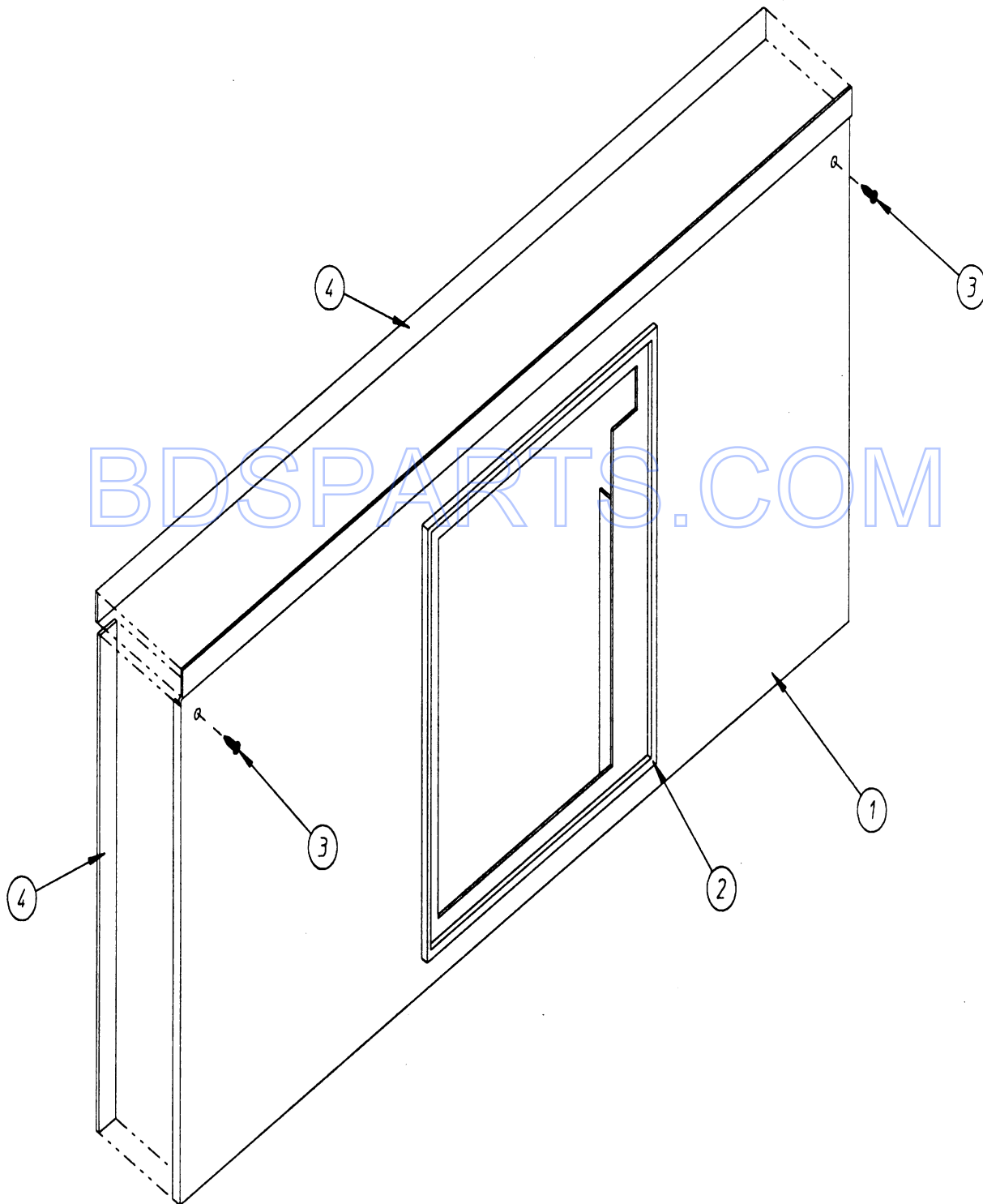

CD21-29

Section: LINT DOOR ASSEMBLY

No.	Part No.	Description	Series	Qty
-	-----	NOT REQUIRED PART OR SEE NOTE Note: ORDER PARTS FROM AMERICAN DRYER CORP AT 508-678-9000.		0
1	A820945	DOOR ASSY. (LINT) Note: (INCLUDES 1, 2 AND 4)		1
2	A117602	TAPE, NOISE SUPPRESSOR Note: GASKET (SOLD IN FEET)		5
3	A150415	SCREW, CRIMPTITE (PH. RD.HD.) Note: SCREW, CRIMPTITE (PH.RD.HD.) (#10-16 X 1/2")		5
4	A117600	GASKET, TAPE (SOLD IN FEET) Note: TAPE, NOISE SUPPRESSOR (SOLD IN FEET)		9

BDSPARTS.COM

*Color Code (-)=Not Shown #=Series, Serial Prefix or Run No., N=Not Available

Section: LINT DRAWER/SWITCH BOX ASSEMBLY

Model: MDG170P1HW

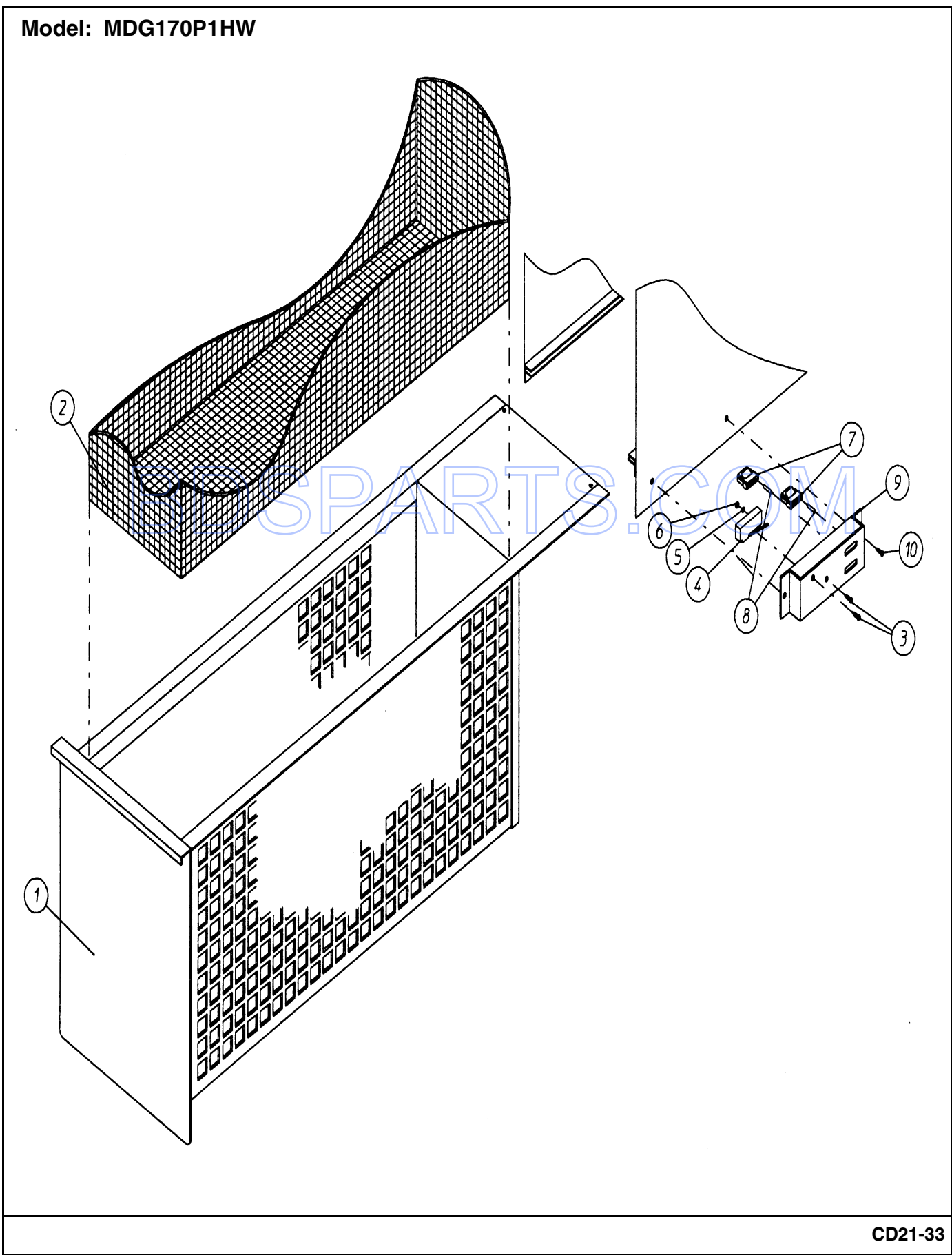

Section: LINT DRAWER/SWITCH BOX ASSEMBLY

No.	Part No.	Description	Series	Qty
-	-----	NOT REQUIRED PART OR SEE NOTE Note: ORDER PARTS FROM AMERICAN DRYER CORP AT 508-678-9000.		0
1	A821046	DRAWER ASSY., LINT Note: DRAWER ASSY., LINT (SPECIFY COLOR WHEN ORDERING)		1
2	A820925	SCREEN ASSY., LINT		1
3	A153532	STUD, CLINCH (#8-32 X 3/4") Note: STUD, CLINCH (#8-32 X 3/4")		2
-	A332348	BRACKET, SWITCH MTG. (ONLY) Note: BRACKET, SWITCH MTG. (ONLY)		1
-	A821116	BRACKET, SWITCH MTG. ASSY. Note: BRACKET, SWITCH MTG. ASSY. (INCLUDES 3 AND 4)		1
4	A821119	SWITCH ASSY. COMPLETE Note: SWITCH ASSY. COMPLETE (INLCUDES 3 - 10)		1
5	A136992	SWITCH, LINT DRAWER (ONLY) Note: SWITCH, LINT DRAWER (ONLY)		1
6	A153000	STEEL BURR (#8)		2
7	A152001	NUT, HEX (#8-32) Note: NUT, HEX (#8-32)		2
8	A122605	CONNECTOR, 4-PIN SOCKET Note: CONNECTOR, SOCKET (4-PIN ONLY)		2
9	A122801	TOOL, EXTRACTION (PIN/SOCKET) Note: TOOL, EXTRACTION (PIN/SOCKET)		1
9	A122701	TERMINAL, SOCKET (ONLY) Note: TERMINAL, SOCKET (ONLY)		4
10	A150415	SCREW, CRIMPTITE (PH. RD.HD.) Note: SCREW, CRIMPTITE (PH.RD.HD.) (#10-16 X 1/2")		2

BDSPARTS.COM

*Color Code (-)=Not Shown #=Series, Serial Prefix or Run No., N=Not Available

Section: MICROPROCESSOR TEMP. SENSOR BRKT. ASSY.

Model: MDG170P1HW

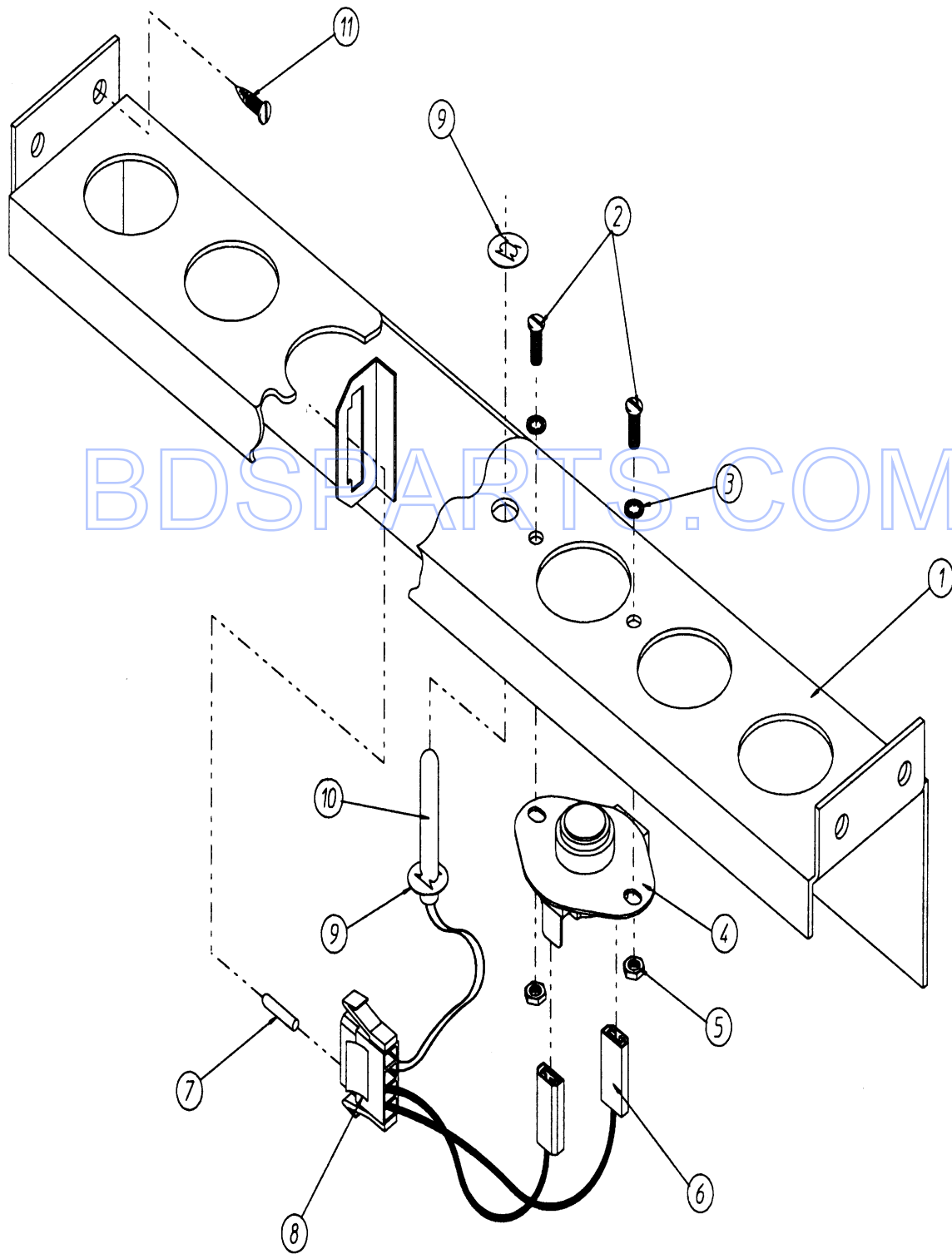

CD21-28

Section: MICROPROCESSOR TEMP. SENSOR BRKT.

No.	Part No.	Description	Series	Qty
-	-----	NOT REQUIRED PART OR SEE NOTE Note: ORDER PARTS FROM AMERICAN DRYER CORP AT 508-678-9000.		0
1	A820968	BRACKET, TEMP. SENSOR (CMPLT.) Note: BRACKET, TEMP. SENSOR (CMPLT.)(INCLUDES 1 - 10 M/PROCESSOR)		1
1	A820967	BRACKET, TEMP. SENSOR (ONLY) Note: (MICROPROCESSOR)		1
2	A150005	SCREW, PHILL (6-32 X 1/4")RND Note: SCREW, MACHINE (RD.HD.) (#6-32 X 1/4")		2
3	A153010	WASHER, STAR (#6) Note: WASHER, STAR (#6)		2
4	A130302	THERMOSTAT, AUTOMATIC (ONLY) Note: THERMOSTAT, AUTOMATIC (225 DEGREES RESET ONLY)		1
5	A152000	NUT, HEX (#6-32) Note: NUT, HEX (#6-32)		2
6	A121028	TERMINAL, 1/4" INSUL. (FEMALE) Note: TERMINAL, INSULATED (1/4" X .032)		2
7	A122701	TERMINAL, SOCKET (ONLY) Note: SOCKET, TERMINAL (ONLY)		4
8	A122605	CONNECTOR, 4-PIN SOCKET Note: CONNECTOR, SOCKET (4-PIN)		1
9	A154007	FASTENER, PUSH-ON (1/4") Note: FASTENER, PUSH-ON (1/4")		2
10	A880251	PROBE ASSY., TEMP. (1/4") Note: PROBE ASSY., TEMP. (1/4") (INCLUDES 6 - 10)		1
11	A150301	SCREW, TEK (#8-18 X 7/16 PH Note: SCREW, TEK (PH.PN.HD.) (#8-18 X 7/16")		4

BDSPARTS.COM

*Color Code (-)=Not Shown #=Series, Serial Prefix or Run No., N=Not Available

Section: BASKET (TUMBLER) SUPPORT ASSEMBLY

Model: MDG170P1HW

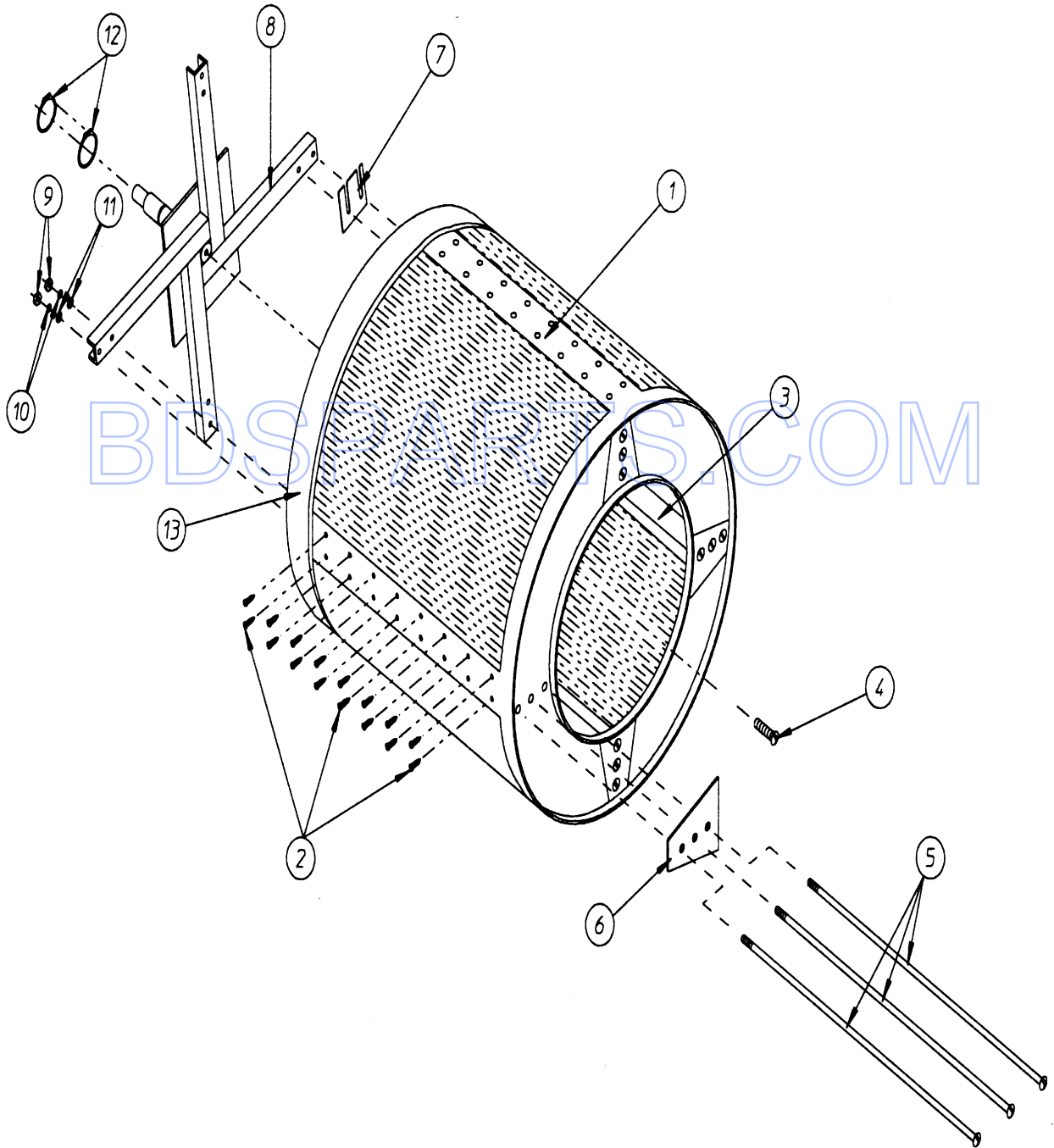

CD16-4

Section: BASKET (TUMBLER) SUPPORT ASSEMBLY

No.	Part No.	Description	Series	Qty
-	-----	NOT REQUIRED PART OR SEE NOTE Note: ORDER PARTS FROM AMERICAN DRYER CORP AT 508-678-9000.		0
1	A821001	BASKET AND SUPPORT ASSY. Note: (INCLUDES 1 - 13. MODELS MFD. WITH ROTATIONAL SENSOR OPTION)		1
1	A820927	BASKET AND SUPPORT ASSEMBLY Note: (INCLUDES 1 - 13. MODELS MFD. WITHOUT ROTATIONAL SENSOR OPTION)		1
1	A820979	BASKET (ONLY) Note: BASKET (ONLY) (FELT COLLAR NOT INCLUDED AND MUST BE ORDERED SEPERATELY)		1
2	A150309	SCREW, CRIMPTITE Note: SCREW, CRIMPTITE (PH.RD.HD.) (#10-16 X 1/2")		64
3	A332140	BASKET, RIB (ONLY) Note: BASKET, RIB (ONLY)		4
4	A150500	SCREW, SOCKET BTTN. HD. Note: SCREW, SOCKET BTTN. HD. (5/16-18" X 3/4")		1
5	A100910	ROD, TIE (1/2-13 X 44")		12
6	A332139	PLATE, REINFORCING BSKT. ONLY Note: PLATE, REINFORCING BSKT. ONLY		4
8	A821000	SUPPORT, BASKET (ONLY) Note: SUPPORT, BASKET (ONLY) (FOR MODELS MFD. WITH ROTATIONAL SENSOR OPTION)		1
8	A820909	SUPPORT, BASKET (ONLY) Note: SUPPORT, BASKET (ONLY) (FOR MODELS MFD. WITHOUT ROTATIONAL SENSOR OPTION)		1
9	A152009	NUT, HEX (#1/2-13)		12
10	A153013	LOCKWASHER (1/2")		12
11	A153014	WASHER, FLAT (9/16")		12
12	A100810	RING, RETAINING (3-1/8")		2
13	A116007	COLLAR, FELT (ONLY) Note: COLLAR, FELT (ONLY)		1

BDSPARTS.COM

*Color Code (-)=Not Shown #=Series, Serial Prefix or Run No., N=Not Available

Section: TUMBLER BEARING MOUNT ASSEMBLY

Model: MDG170P1HW

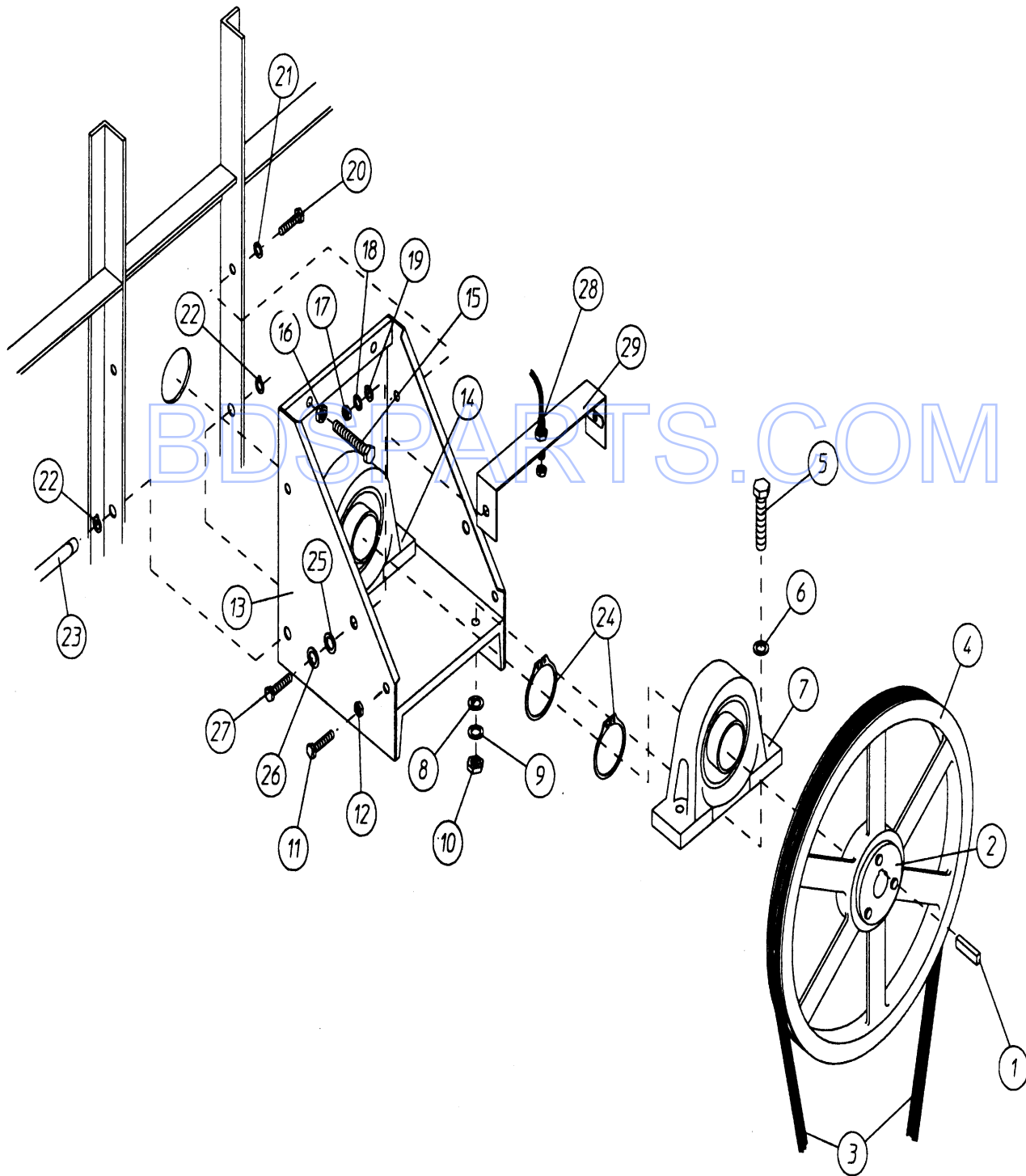

CD16-3

Section: TUMBLER BEARING MOUNT ASSEMBLY

No.	Part No.	Description	Series	Qty
-	-----	NOT REQUIRED PART OR SEE NOTE Note: ORDER PARTS FROM AMERICAN DRYER CORP AT 508-678-9000.		0
1	A100703	KEY (1/2" X 1/2" X 2")		1
2	A101137	BUSHING (2-1/4" SFX)		1
3	A100137	V-BELT Note: (REPLACE IN MATCH SETS..BOTH BELTS)		2
4	A101182	PULLEY, BASKET (25")		1
5	A150602	BOLT, MACHINE (HX.HD.) Note: (#5/8-11 X 3")		4
6	A153016	WASHER, FLAT (5/8") Note: WASHER, FLAT (5/8")		4
7	A880223	BEARING, PILLOW BLOCK Note: BEARING, PILLOW BLOCK (3-1/8" ONLY)		1
8	A153016	WASHER, FLAT (5/8") Note: WASHER, FLAT (5/8")		4
9	A153015	WASHER, LOCK (5/8")		4
10	A152010	NUT, HEX (#5/8-11) Note: NUT, HEX (#5/8-11)		4
11	A150600	BOLT, MACHINE (#16-3/8 X 11/2) Note: BOLT, MACHINE (HX.HD.) (#3/8-16 X 1 1/2")		2
12	A152005	NUT, HEX (#16-3/8") Note: NUT, HEX (#3/8-16)		2
13	A820910	MOUNT, TUMBLER BEARING (ONLY) Note: MOUNT, TUMBLER BEARING (ONLY)		1
14	A880223	BEARING, PILLOW BLOCK		1
15	A150603	BOLT, MACHINE (SQ.HD.) Note: BOLT, MACHINE (SQ.HD.) (#1/2-13 X 3")		2
16	A152011	NUT, HEX (#1/2-13) Note: NUT, HEX (#1/2-13)		2
17	A152005	NUT, HEX (#16-3/8") Note: NUT, HEX (#3/8-16)		2
18	A153005	WASHER, LOCK (3/8")		2
19	A153004	WASHER, FLAT (3/8") Note: WASHER, FLAT (3/8")		4
20	A150600	BOLT, MACHINE (#16-3/8 X 11/2) Note: BOLT, MACHINE (HX.HD.) (#3/8-16 X 1-1/2")		2
21	A153004	WASHER, FLAT (3/8") Note: WASHER, FLAT (3/8")		2
22	A100801	RING, RETAINING (5/8")		2
23	A332153	PIN, HINGE (5/8") Note: PIN, HINGE (5/8")		1
24	A100810	RING, RETAINING (3-1/8")		2
25	A153018	WASHER, FLAT (1/4")		2
26	A153007	WASHER, LOCK (1/4") Note: LOCK WASHER (1/4")		2
27	A150512	BOLT, MACHINE (HX.HD.) Note: BOLT, MACHINE (HX.HD.) (#1/4-20 X 1/2")		2
28	A824807	SENSOR ASSY. (ROTATIONAL)		1
29	A880841	BRACKET, MOUNTING (SENSOR) Note: BRACKET, MOUNTING (SENSOR)		1

*Color Code (-)=Not Shown #=Series, Serial Prefix or Run No., N=Not Available

Section: IDLER BEARING MOUNT ASSEMBLY

Model: MDG170P1HW

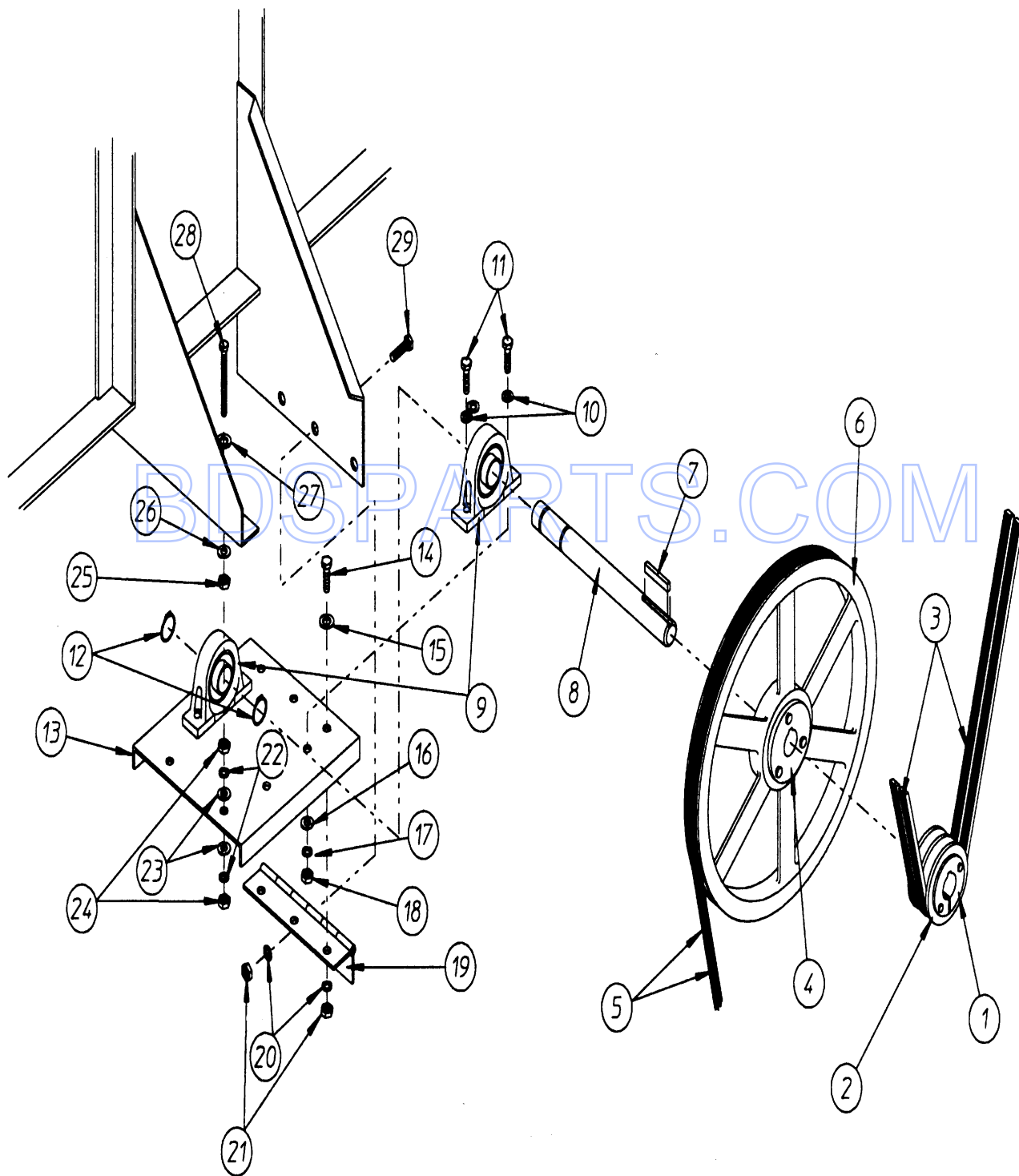

CD21-27

Section: IDLER BEARING MOUNT ASSEMBLY

No.	Part No.	Description	Series	Qty
-	-----	NOT REQUIRED PART OR SEE NOTE Note: ORDER PARTS FROM AMERICAN DRYER CORP AT 508-678-9000.		0
1	A101152	BUSHING (SH X 1-3/8")		1
2	A101143	PULLEY (2B X 3.8)		1
3	A100137	V-BELT Note: (REPLACE IN MATCHED SETS..BOTH BELTS)		2
4	A101184	BUSHING, BORE (SK X 1-3/8")		1
5	A100102	V BELT Note: (REPLACE IN MATCHED SETS..BOTH BELTS)		2
6	A101112	PULLEY, IDLER (19" ONLY) Note: PULLEY, IDLER (19" ONLY)		1
7	A100730	KEY (5/16" X 5/16" X 4")		1
8	A332152	SHAFT, IDLER (ONLY) Note: SHAFT, IDLER (ONLY)		1
9	A880879	BEARING, PILLOW BLOCK (1 3/8") Note: (WITH SET SCREWS & GREASE FITTINGS)		2
10	A153011	WASHER, FLAT (9/16")		4
11	A150606	BOLT, MACHINE (HX.HD.) Note: BOLT, MACHINE (HX.HD.) (#1/2-13 X 2")		4
12	A100802	RING, RETAINING (1-3/8")		2
13	A332151	MOUNT, IDLER BEARING (ONLY) Note: MOUNT, IDLER BEARING (ONLY)		1
13	A820932	IDLER BEARING MOUNT ASSY. Note: (INCLUDES 8 - 11 & 17 - 25)		1
14	A150501	BOLT, MACHINE (#18-5/16 X 3/4) Note: BOLT, MACHINE (HX.HD.) (#5/16-18 X 3/4")		3
15	A153001	WASHER, FLAT (5/16") Note: LOCK WASHER (5/16")		3
16	A153011	WASHER, FLAT (9/16")		4
17	A153026	WASHER, LOCK (1/2")		4
18	A152011	NUT, HEX (#1/2-13) Note: NUT, HEX (#1/2-13)		4
19	A103005	HINGE, IDLER ADJUSTMENT (ONLY) Note: HINGE, IDLER ADJUSTMENT (ONLY)		1
20	A153002	WASHER, LOCK (5/16")		6
21	A152004	NUT, HEX (#18-5/16) Note: NUT, HEX (#5/16-18)		6
22	A153005	WASHER, LOCK (3/8")		4
23	A153004	WASHER, FLAT (3/8") Note: WASHER, FLAT (3/8")		4
24	A152005	NUT, HEX (#16-3/8") Note: NUT, HEX (#3/8-16)		4
25	A152005	NUT, HEX (#16-3/8") Note: NUT, HEX (#3/8-16)		2
26	A153005	WASHER, LOCK (3/8")		2
27	A153005	WASHER, LOCK (3/8")		2
28	A152034	BOLT Note: BOLT (HX.HD. #3/18-16 X 3-1/2")		2
29	A150501	BOLT, MACHINE (#18-5/16 X 3/4) Note: BOLT, MACHINE (HX.HD.) (#5/16-18 X 3/4")		3

*Color Code (-)=Not Shown #=Series, Serial Prefix or Run No., N=Not Available

Section: FAN COOLED BASKET MOTOR MOUNT ASSEMBLY

Model: MDG170P1HW

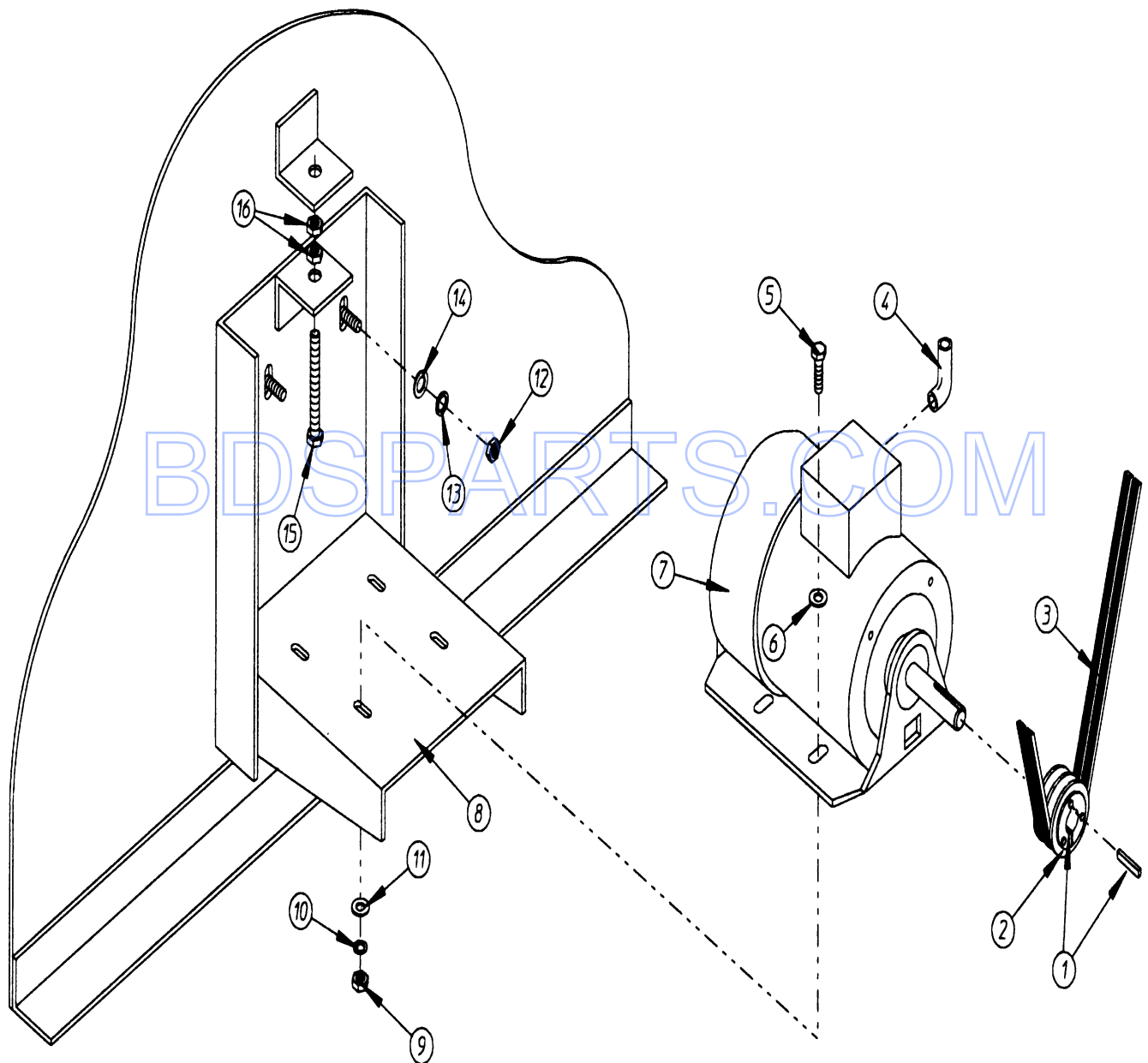

CD17-11

Section: FAN COOLED BASKET MOTOR MOUNT ASS

No.	Part No.	Description	Series Qty
-	-----	NOT REQUIRED PART OR SEE NOTE Note: ORDER PARTS FROM AMERICAN DRYER CORP AT 508-678-9000.	0
1	A101121	BUSHING (5/8" SK)	1
2	A101114	PULLEY (2.65") Note: (FOR 60HZ MODELS ONLY)	1
3	A100102	V BELT Note: (REPLACE IN MATCHED SETS..BOTH BELTS)	3
4	A120200	CONNECTOR (3/8" X 90 DEG.) Note: CONNECTOR (3/8" X 90 DEG.)	1
5	A150501	BOLT, MACHINE (#18-5/16 X 3/4) Note: BOLT, MACHINE (HX.HD.) (#5/16-18 X 3/4")	4
6	A153001	WASHER, FLAT (5/16") Note: WASHER, FLAT (5/16")	4
7	A100050	MOTOR Note: (1 HP 208/230/380/460V 50/60HZ T.E.F.C. 56Z FRAME)	1
-	A800952	MOUNT, TUMBLER MOTOR (ONLY) Note: (56Z FRAME)	1
8	A820941	MOTOR MOUNT ASSY. COMPLETE Note: (INCLUDES 1, 4 - 11, 15 AND 16 MOTOR PULLEY MUST BE ORDER SEPERATELY...SPECIFY VOLTAGE WHEN ORDERING)	1
9	A152004	NUT, HEX (#18-5/16) Note: NUT, HEX (#5/16-18)	4
10	A153002	WASHER, LOCK (5/16")	4
11	A153001	WASHER, FLAT (5/16") Note: WASHER, FLAT (5/16")	4
12	A152004	NUT, HEX (#18-5/16) Note: NUT, HEX (#5/16-18)	4
13	A153002	WASHER, LOCK (5/16")	4
14	A153001	WASHER, FLAT (5/16") Note: WASHER, FLAT (5/16")	4
15	A150619	BOLT, MACHINE (HX.HD.) Note: BOLT, MACHINE (HX.HD.) (#3/8-16 X 3")	1
16	A152005	NUT, HEX (#16-3/8") Note: NUT, HEX (#3/8-16)	2
-	-----	NOT REQUIRED PART OR SEE NOTE Note: -----NOTE----- (IMPORTANT: FOR VOLTAGES HIGHER THAN 460V, CONTACT THE FACTORY FOR CORRECT PART NUMBER OF MOTOR OR MOTOR MOUNT ASSEMBLY)	1

*Color Code (-)=Not Shown #=Series, Serial Prefix or Run No., N=Not Available

Section: BLOWER MOTOR MOUNT ASSEMBLY

Model: MDG170P1HW

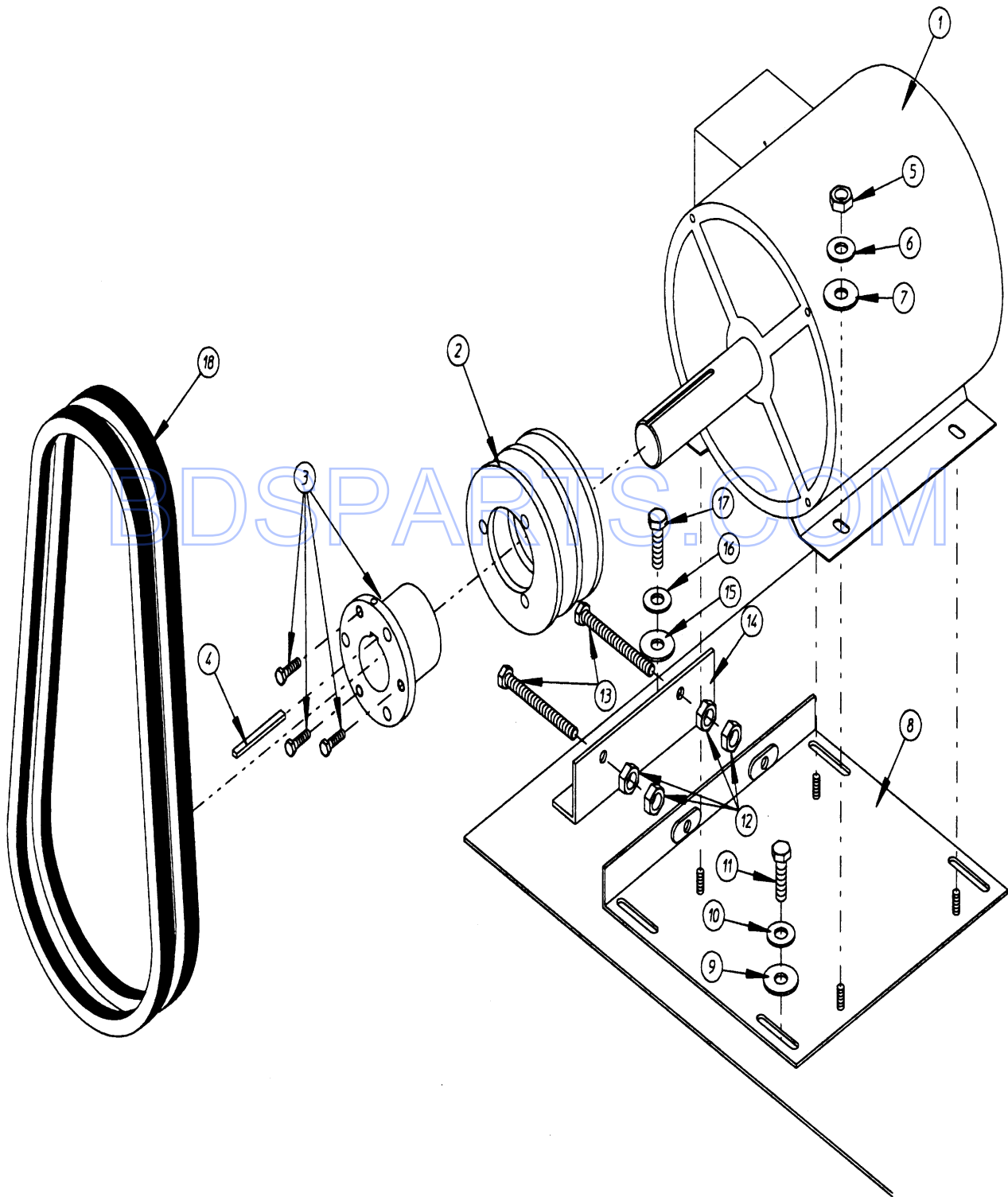

CD17-10

Section: BLOWER MOTOR MOUNT ASSEMBLY

No.	Part No.	Description	Series	Qty
-	-----	NOT REQUIRED PART OR SEE NOTE Note: ORDER PARTS FROM AMERICAN DRYER CORP AT 508-678-9000.		0
1	A100046	MOTOR Note: (7.5 HP 208-230/460 FOR 60HZ MODELS ONLY)		1
2	A101148	PULLEY, MOTOR Note: (SB X 4.0 FOR 60HZ MODELS ONLY)		1
3	A101152	BUSHING (SH X 1-3/8") Note: (FOR 60HZ MODELS ONLY)		1
4	A100706	KEY (5/16" X 5/16" X 1 3/8")		1
5	A152004	NUT, HEX (#18-5/16) Note: NUT, HEX (5/16-18)		4
6	A153002	WASHER, LOCK (5/16")		4
7	A153001	WASHER, FLAT (5/16") Note: WASHER, FLAT (5/16")		4
8	A821091	PLATE, MOTOR MOUNT ADJUSTMENT Note: PLATE, MOTOR MOUNT ADJUSTMENT (ONLY)		1
9	A153001	WASHER, FLAT (5/16") Note: WASHER, FLAT (5/16")		4
10	A153002	WASHER, LOCK (5/16")		4
11	A150501	BOLT, MACHINE (#18-5/16 X 3/4) Note: BOLT, MACHINE (#5/16-18 X 3/4" HX.HD.)		4
12	A152004	NUT, HEX (#18-5/16) Note: NUT, HEX (5/16-18)		4
13	A150503	BOLT, MACHINE (HX.HD.) Note: (#5/16-18 X 2")		2
14	A332322	ANGLE, MOTOR MOUNT ADJUSTMENT Note: (ONLY)		1
15	A153001	WASHER, FLAT (5/16") Note: WASHER, FLAT (5/16")		2
16	A153002	WASHER, LOCK (5/16")		2
17	A150501	BOLT, MACHINE (#18-5/16 X 3/4) Note: BOLT, MACHINE (#5-16-18 X 3/4" HX.HD.)		2
18	A100128	BELT, COGGED (BX-50) Note: BELT, COGGED (BX-50) (FOR 60HZ MODELS ONLY. REPLACE IN MATCHED SETS..BOTH BELTS)		2

BDSPARTS.COM

*Color Code (-)=Not Shown #=Series, Serial Prefix or Run No., N=Not Available

Section: FAN SHAFT MOUNT ASSEMBLY

Model: MDG170P1HW

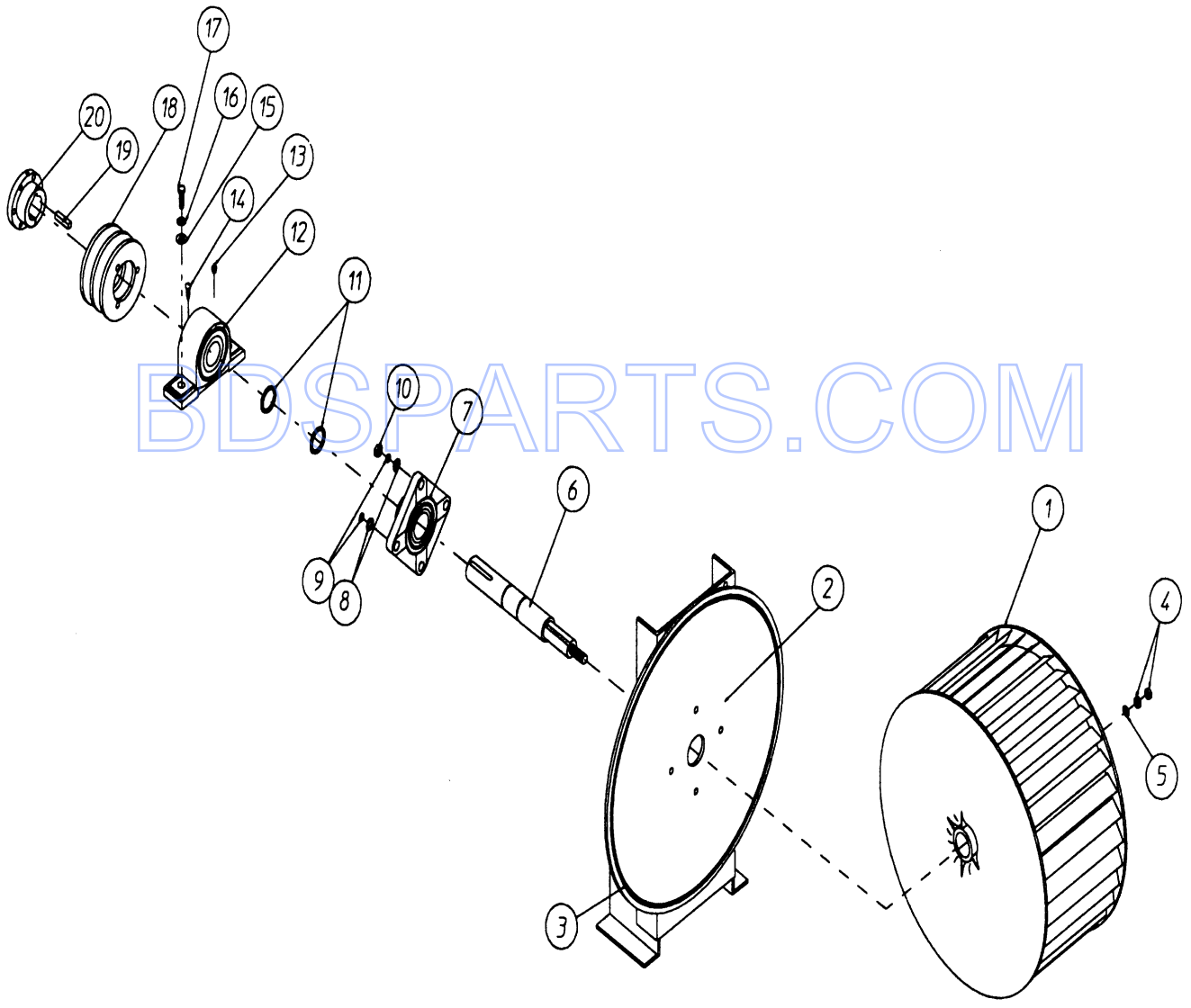

BDS PARTS.COM

Section: FAN SHAFT MOUNT ASSEMBLY

No.	Part No.	Description	Series	Qty
-	-----	NOT REQUIRED PART OR SEE NOTE Note: ORDER PARTS FROM AMERICAN DRYER CORP AT 508-678-9000.		0
1	A100612	WHEEL, BLOWER Note: (1-1/4" BORE X 15 DIAMETER X 6")		1
2	A821078	FAN SHAFT MOUNT ASSY. COMPLETE Note: (INCLUDES ITEMS 1 - 20)		1
2	A821073	MOUNT, FAN SHAFT (ONLY) Note: MOUNT, FAN SHAFT (ONLY)		1
3	A117604	TAPE, FOAM (SOLD IN FEET) Note: TAPE, NOISE SUPPRESSOR (SOLD IN FEET)		4
4	A152006	NUT, JAM (#20-1/2" LT-HAND) Note: NUT, JAM (LT. HAND #1/2-20)		2
5	A153050	WASHER, FLAT (1/2") Note: WASHER, FLAT (1/2")		1
6	A332280	SHAFT, FAN (ONLY) Note: SHAFT, FAN (ONLY)		1
7	A881061	BEARING, FLANGE (1-3/8") Note: BEARING, FLANGE (1-3/8") (W/SET SCREWS & GREASE FITTINGS)		1
8	A153004	WASHER, FLAT (3/8") Note: WASHER, FLAT (3/8")		4
9	A153005	WASHER, LOCK (3/8")		4
10	A152005	NUT, HEX (#16-3/8") Note: NUT, HEX (#3/8-16)		4
11	A100812	RING, RETAINING (1-3/8")		2
12	A880879	BEARING, PILLOW BLOCK (1 3/8") Note: BEARING, PILLOW BLOCK (1-3/8")(INCLUDES 12, 13 AND 14 ONLY)		1
13	A170511	FITTING, GREASE (ONLY) Note: FITTING, GREASE (ONLY) (#1/8-27 N.P.T. ZIRC)		2
13	A170512	FITTING, GREASE (ONLY) Note: (#1/4-28 TAPPERED ZIRC)		2
14	A154326	SCREW, CONE POINT SET Note: SCREW, CONE POINT SET (#5/16-24 X 3/8")		4
15	A153004	WASHER, FLAT (3/8") Note: WASHER, FLAT (3/8")		2
16	A153005	WASHER, LOCK (3/8")		2
17	A150617	BOLT, MACHINE (#16-3/8 X 1") Note: BOLT, HX. HD. (#3-16 X 1")		2
18	A101177	PULLEY (2B X 5.8) Note: PULLEY (2B X 5.8)		1
19	A100706	KEY (5/16" X 5/16" X 1 3/8") Note: KEY (5/16" X 5/16" X 1-3/8")		1
20	A101194	BUSHING (SDS X 1 3/8" ONLY) Note: BUSHING (SDS X 1 3/8" ONLY)		1

*Color Code (-)=Not Shown #=Series, Serial Prefix or Run No., N=Not Available

Section: D.S.I. BURNER ASSY. (NATURAL GAS)

Model: MDG170P1HW

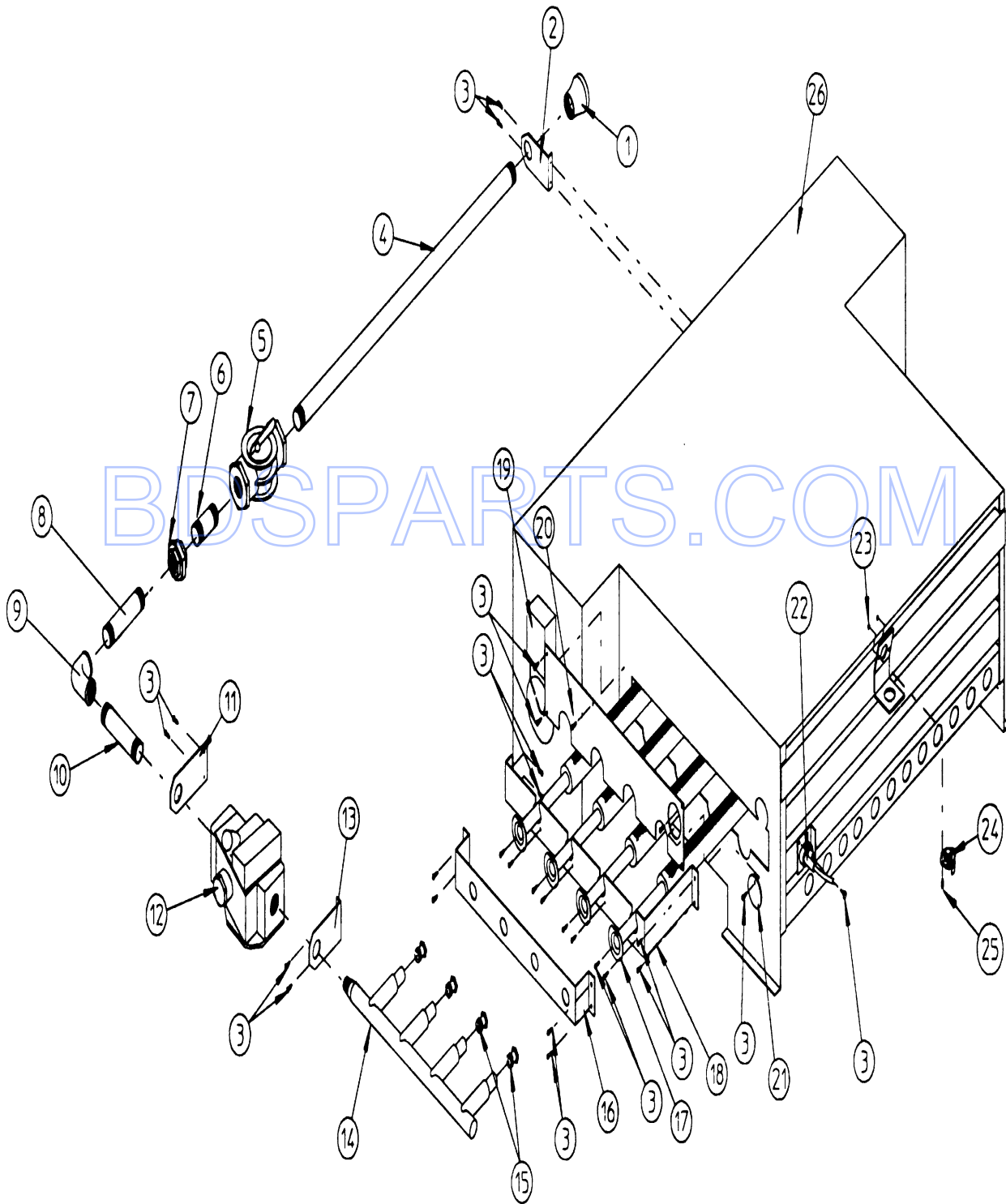

CD14-4

Section: D.S.I. BURNER ASSY. (NATURAL GAS)

No.	Part No.	Description	Series	Qty
-	-----	NOT REQUIRED PART OR SEE NOTE Note: ORDER PARTS FROM AMERICAN DRYER CORP AT 508-678-9000.		0
1	A142929	COUPLING, REDUCING Note: (1-1/2" TO 1")		1
2	A332117	BRACKET, PIPE		1
3	A150309	SCREW, CRIMPTITE Note: (#10-16 X 1/2" PH.RD.HD.)		31
4	A142817	PIPE (1" X 28-1/2")		1
5	A141302	SHUTOFF, UNION (1")		1
-	A142583	NIPPLE, 1" X 40"		1
-	A142507	STREET ELBOW, 1" X 90		1
-	A142808	NIPPLE, 1" X 3"		1
6	A142724	NIPPLE (1" X 2")		1
7	A142602	UNION (1")		1
8	A142581	NIPPLE (1" X 5")		1
9	A142548	ELBOW (1" X 90 DEG.)		1
10	A142581	NIPPLE (1" X 5")		1
11	A332334	BRACKET, GAS VALVE PIPE		1
12	A140017	VALVE, GAS (REDUNDANT ONLY) Note: VALVE, GAS (REDUNDANT ONLY)		1
13	A332119	BRACKET, GAS VALVE PIPE		1
14	A141240	MANIFOLD (4-PORT ONLY) Note: MANIFOLD (4-PORT ONLY)		1
15	A140839	ORIFICE, BURNER (#2 ONLY) Note: ORIFICE, BURNER-#2 ONLY NTLGAS(CONSULT FACTORY FOR ELEVATIONS OVER 2,000 FT)		4
16	A332114	SUPPORT, MANIFOLD (ONLY) Note: SUPPORT, MANIFOLD (ONLY)		1
17	A881492	TUBE, BURNER (ONLY)		4
18	A332121	SUPPORT, BURNER TUBE (ONLY) Note: SUPPORT, BURNER TUBE (ONLY)		1
19	-----	NOT REQUIRED PART OR SEE NOTE Note: SWITCH, SAIL (REFER TO SAIL SWITCH ASSY. SECTION)		0
20	A332113	PLATE, BRNR. BOX CVR. (ONLY) Note: PLATE, BRNR. BOX CVR. (ONLY)		1
21	A331290	DISC, IGNITOR/FLAME PROBE Note: (ONLY)		1
-	A305410	GAUGE, IGNITOR GAP FEELER Note: GAUGE, IGNITOR GAP FEELER		1
22	A880330	CONNECTOR, IGNITOR HV WIRE Note: CONNECTOR, IGNITOR HV WIRE (ONLY)		1
22	A880325	IGNITER/FLAME PROBE ASSY. KIT Note: IGNITOR/FLAME PROBE ASSY. KIT (INCLUDES HV WIRE & CONNECTOR)		1
22	A128915	DSI IGNITER & FLAME PROBE ONLY Note: PROBE, IGNITOR/FLAME ONLY		1
23	A151000	PAL NUT (#6-32)		2
24	A130403	THERMOSTAT (330 DEGREE) Note: HI-LIMIT (330 DEG. ONLY)		1
-	A130201	HI-LIMIT	14	1
25	A151001	NUT, PAL (#8-32) Note: SCREW, MACHINE (RD.HD. #6-32 X 1/2")		2
26	A820987	BOX, BURNER (ONLY) Note: BOX, BURNER (ONLY)		1
26	A821106	BURNER ASSY. (LESS ORIFICES) Note: (NAT. GAS INCLUDES ITEMS 1-14 AND 16 - 26...ORIFICES NOT INCLUDED AND MUST BE ORDERED SEPERATELY)		1

*Color Code (-)=Not Shown #=Series, Serial Prefix or Run No., N=Not Available

Section: D.S.I. BURNER ASSEMBLY (L.P.)

Model: MDG170P1HW

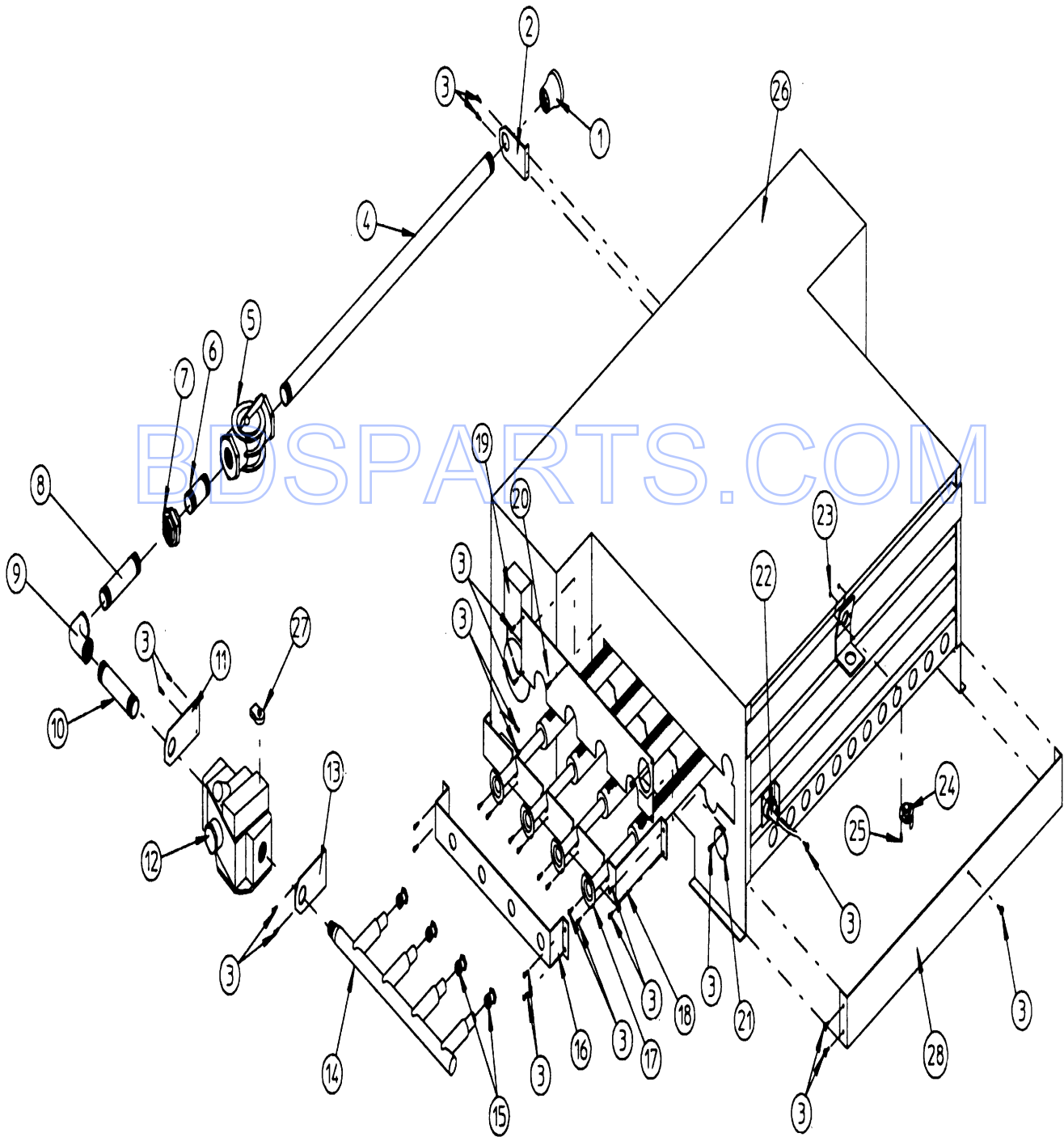

CD14-3

Section: D.S.I. BURNER ASSEMBLY (L.P.)

No.	Part No.	Description	Series	Qty
-	-----	NOT REQUIRED PART OR SEE NOTE Note: ORDER PARTS FROM AMERICAN DRYER CORP AT 508-678-9000.		0
1	A142929	COUPLING, REDUCING Note: COUPLING, REDUCING (1-1/2 - 1)		1
2	A332117	BRACKET, PIPE		1
3	A150307	SCREW, CRIMPTITE (PH. RD.HD.) Note: (#10-16 X 1/2" PH.HD.RD.)		36
4	A142817	PIPE (1" X 28-1/2")		1
5	A141302	SHUTOFF, UNION (1")		1
6	A142724	NIPPLE (1" X 2")		1
7	A142602	UNION (1")		1
8	A142581	NIPPLE (1" X 5")		1
9	A142548	ELBOW (1" X 90 DEG.)		1
10	A142581	NIPPLE (1" X 5")		1
11	A332334	BRACKET, GAS VALVE PIPE		1
12	A140017	VALVE, GAS (REDUNDANT ONLY) Note: VALVE, GAS-1" 24 VAC N.G.VALVE		1
12	A140018	CONVERSION KIT (L.P.) Note: CONVERSION KIT (L.P.) (1" 24 VAC GAS VALVE)		1
13	A332119	BRACKET, GAS VALVE PIPE		1
14	A141240	MANIFOLD (4-PORT ONLY)		1
15	A140820	ORIFICE, BURNER (NAT) Note: ORIFICE, BURNER (ONLY) (#29 LP GAS ONLY) (CONSULT FACTORY FOR ELEVATIONS OVER 2,000 FT)		4
16	A332114	SUPPORT, MANIFOLD (ONLY) Note: SUPPORT, MANIFOLD (ONLY)		1
17	A881492	TUBE, BURNER (ONLY)		4
18	A332121	SUPPORT, BURNER TUBE (ONLY) Note: SUPPORT, BURNER TUBE (ONLY)		1
19	-----	NOT REQUIRED PART OR SEE NOTE Note: SWITCH, SAIL (REFER TO SAIL SWITCH ASSY. SECTION)		0
20	A332113	PLATE, BRNR. BOX CVR. (ONLY) Note: PLATE, BURNER BOX CVR. (ONLY)		1
21	A331290	DISC, IGNITOR/FLAME PROBE		1
-	A305410	GAUGE, IGNITOR GAP FEELER Note: GAUGE, IGNITOR GAP FEELER		1
22	A880330	CONNECTOR, IGNITOR HV WIRE Note: CONNECTOR, DSI IGNITOR WIRE		1
22	A128915	DSI IGNITER & FLAME PROBE ONLY Note: PROBE, IGNITOR/FLAME (ONLY)		1
23	A151000	PAL NUT (#6-32)		2
24	A130403	THERMOSTAT (330 DEGREE) Note: HI-LIMIT (330 DEG. ONLY)		1
25	A151001	NUT, PAL (#8-32) Note: SCREW, MACHINE (#6-32 X 1/2" RD.HD.)		2
26	A820987	BOX, BURNER (ONLY) Note: BOX, BURNER (ONLY)		1
26	A821107	BURNER ASSY. COMPLETE Note: (INCLUDES 1 - 14 & 16 - 27 . . . ORIFICES NOT INCLUDED AND MUST BE ORDERED SEPERATELY)		1
27	A332256	BAFFLE, BURNER KIT (ONLY) Note: BAFFLE, BURNER KIT (ONLY)		1
-	A880978	CONVERSION KIT (L.P.) Note: CONVERSION KIT (L.P.) (ORIFICES NOT INCLUDED AND MUST BE ORDERED SEPERATELY)		1

*Color Code (-)=Not Shown #=Series, Serial Prefix or Run No., N=Not Available

Section: D.S.I. MODULE MOUNT ASSEMBLY

Model: MDG170P1HW

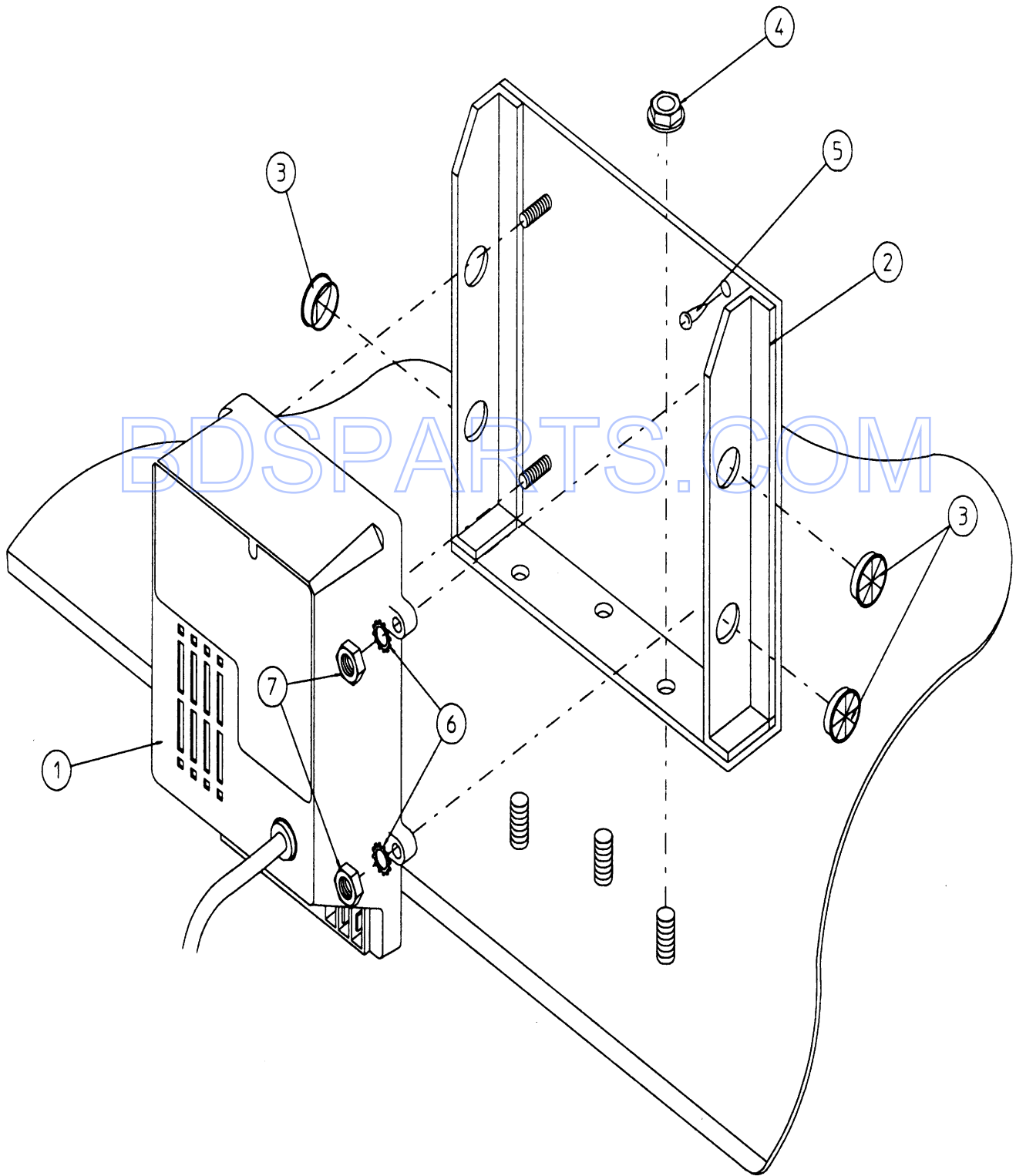

CD21-24

Section: D.S.I. MODULE MOUNT ASSEMBLY

No.	Part No.	Description	Series	Qty
-	-----	NOT REQUIRED PART OR SEE NOTE Note: ORDER PARTS FROM AMERICAN DRYER CORP AT 508-678-9000.		0
1	A880815	MODULE, DSI Note: MODULE ONLY (50/60HZ)		1
2	A820100	MODULE MOUNT ASSY. (ONLY)		1
3	A121400	BUSHING (UNIVERSAL)		3
4	A152014	NUT, FREE SPIN WASH (#20-1/4) Note: NUT, FREE SPIN WASH (1/4-20)		3
5	A150301	SCREW, TEK (#8-18 X 7/16 PH Note: SCREW (#8-18 X 7/16"PH.PN.HD.)		1
6	A153010	WASHER, STAR (#6) Note: WASHER, STAR (#6)		4
7	A152000	NUT, HEX (#6-32) Note: NUT, HEX (#6-32)		4

BDSPARTS.COM

*Color Code (-)=Not Shown #=Series, Serial Prefix or Run No., N=Not Available

Section: SAIL SWITCH ASSEMBLY

Model: MDG170P1HW

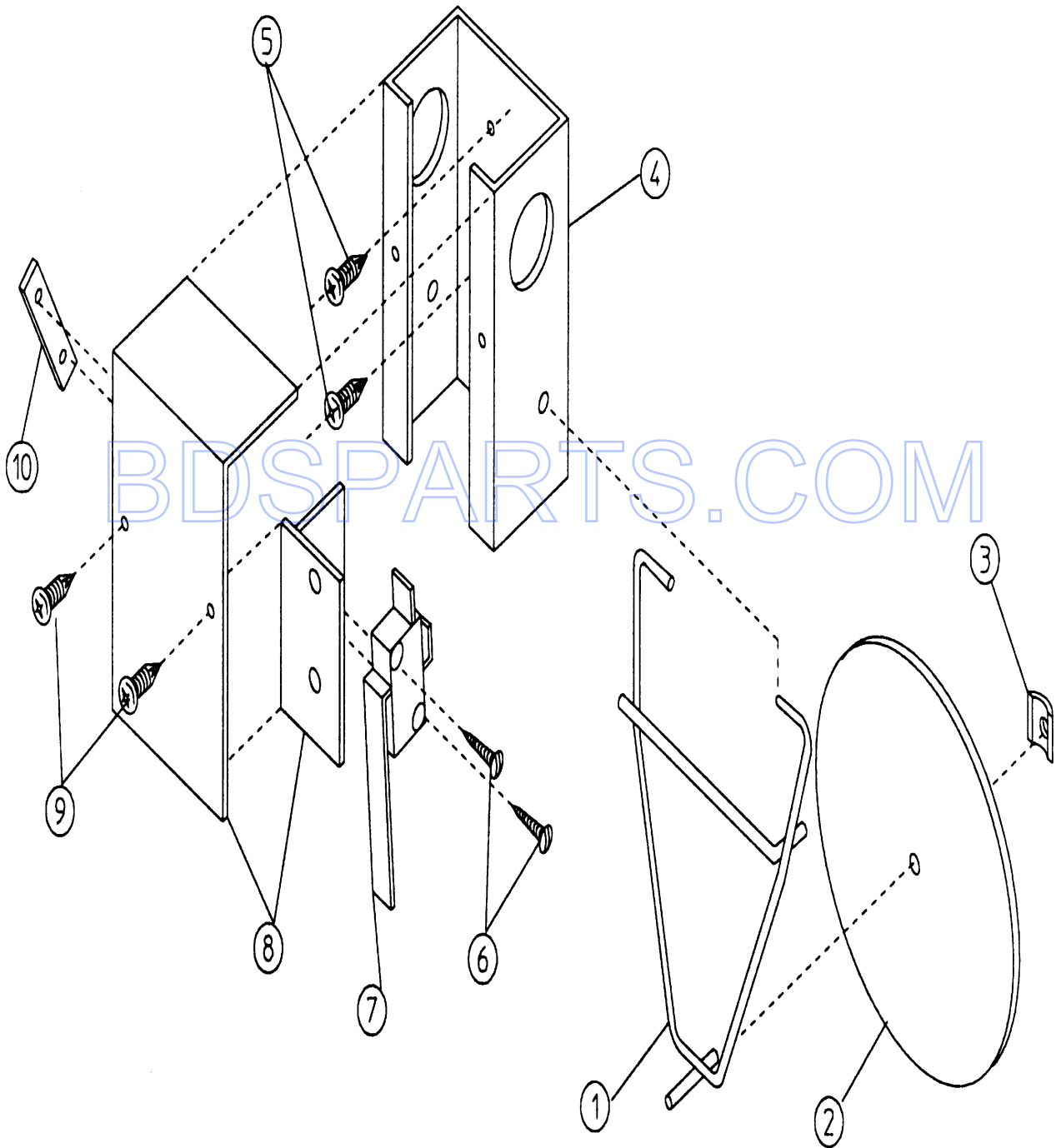

CD21-23

Section: SAIL SWITCH ASSEMBLY

No.	Part No.	Description	Series	Qty
-	-----	NOT REQUIRED PART OR SEE NOTE Note: ORDER PARTS FROM AMERICAN DRYER CORP AT 508-678-9000.		0
1	A105500	ROD, SAIL SWITCH ACTUATOR Note: ROD, SAIL SWITCH ACTUATOR		1
2	A319202	DAMPER, SAIL SWITCH (FLAT) Note: DAMPER, SAIL SWITCH (FLAT)		1
3	A154002	FASTENER, PUSH-ON (1/8")		1
4	A802801	BOX, SAIL SWITCH ASSY Note: BOX, SAIL SWITCH ASSEMBLY (INCLUDES 1 - 4 & 6 - 10)		1
4	A802800	BOX, SAIL SWITCH (ONLY) Note: BOX, SAIL SWITCH (ONLY) (WITH COVER AND BRACKET)		1
5	A150300	SCREW (#10-32 X 1/2" PH ROUND Note: SCREW, TEK (HEX WASHER #10 X 1/2")		2
6	A150303	SCREW (#4 X 3/4") Note: SCREW, MACHINE (PN.HD. "A" #4 X 3/4")		2
7	A122200	SWITCH, SAIL Note: SWITCH, SAIL (ONLY)		1
8	A802799	COVER, SAIL SWITCH BOX W/BRKT. Note: COVER, SAIL SWITCH BOX W/BRKT.(ONLY)		1
9	A150309	SCREW, CRIMPTITE Note: (PH.RD.HD. #10-16 X 1/2")		2
10	A154004	NUT, TWIN SPEED Note: NUT, TWIN SPEED		1

BDSPARTS.COM

*Color Code (-)=Not Shown #=Series, Serial Prefix or Run No., N=Not Available

Section: M/PROCESSOR REV. CNTCTR MTG. PNL. ASSY.

Model: MDG170P1HW

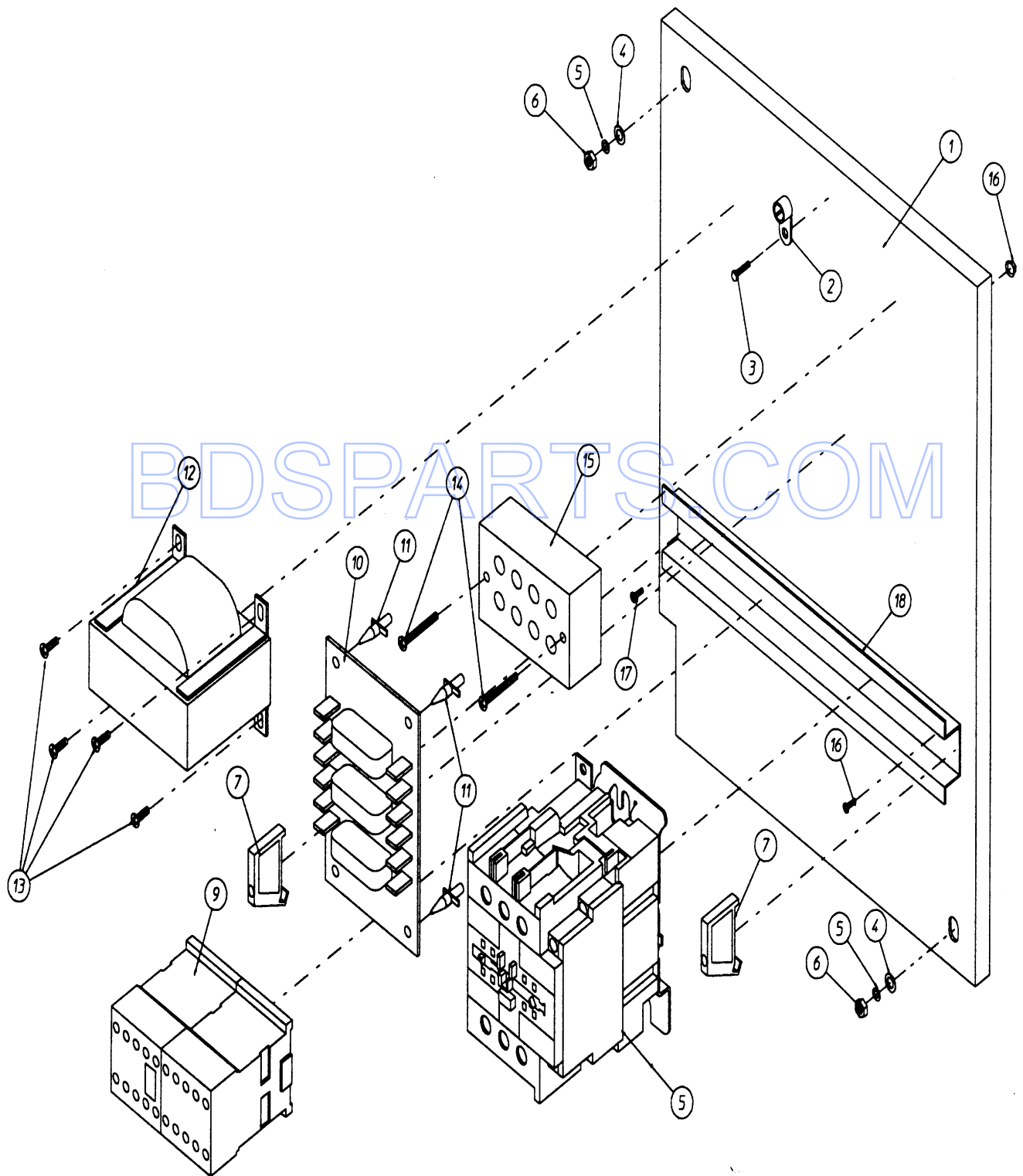

BDSPARTS.COM

Section: M/PROCESSOR REV. CNTCTR MTG. PNL. AS

No.	Part No.	Description	Series Qty
-	-----	NOT REQUIRED PART OR SEE NOTE Note: ORDER PARTS FROM AMERICAN DRYER CORP AT 508-678-9000.	0
1	A332346	PANEL, RELAY/CONTACTOR (ONLY) Note: PANEL, RELAY/CONTACTOR (ONLY)	1
2	A121010	LUG, GROUND (L-70) Note: LUG, GROUND (L-70)	1
3	A150108	SCREW, MACHINE Note: (PH.HD. #8-32 X 1/2")	1
4	A153001	WASHER, FLAT (5/16") Note: WASHER, FLAT (5/16")	2
5	A153002	WASHER, LOCK (5/16")	2
6	A152004	NUT, HEX (#18-5/16) Note: NUT, HEX (#5/16-18)	2
7	A120765	BRACKET, END STOP	2
8	A132465	CONTACTOR, REVERSING 7.5HP Note: (IMPELLOR/BLOWER/FAN 24 VAC.)	1
9	A132432	COIL, CONTACTOR REPLACEMENT Note: COIL, CONTACTOR REPLACEMENT (24VAC.)	1
10	A137060	BOARD, SUPPRESSOR (ARC)	1
11	A137013	STANDOFF, NYLON	4
12	-----	NOT REQUIRED PART OR SEE NOTE Note: TRANSFORMER, STEP-DOWN (REFER TO STEP-DOWN TRANSFORMER APPLICATION LISTING SECTION)	0
13	A150300	SCREW (#10-32 X 1/2" PH ROUND Note: SCREW, TEK (HEX WASHER #10 X 1/2")	4
14	A150008	SCREW, MACHINE Note: (RD.HD. SLOTTED 6-32 X 1 1/4")	2
15	A120701	BLOCK, POWER DISTRIBUTION Note: (4-POSITION)	1
16	A151000	PAL NUT (#6-32)	2
17	A150309	SCREW, CRIMPTITE Note: (PH.RD.HD. #10-16 X 1/2")	2
18	A120768	RAIL, DIN MOUNTING Note: (SOLD IN INCHES)	9

BDSPARTS.COM

*Color Code (-)=Not Shown #=Series, Serial Prefix or Run No., N=Not Available

Section: TOP CONSOLE ASSEMBLY

Model: MDG170P1HW

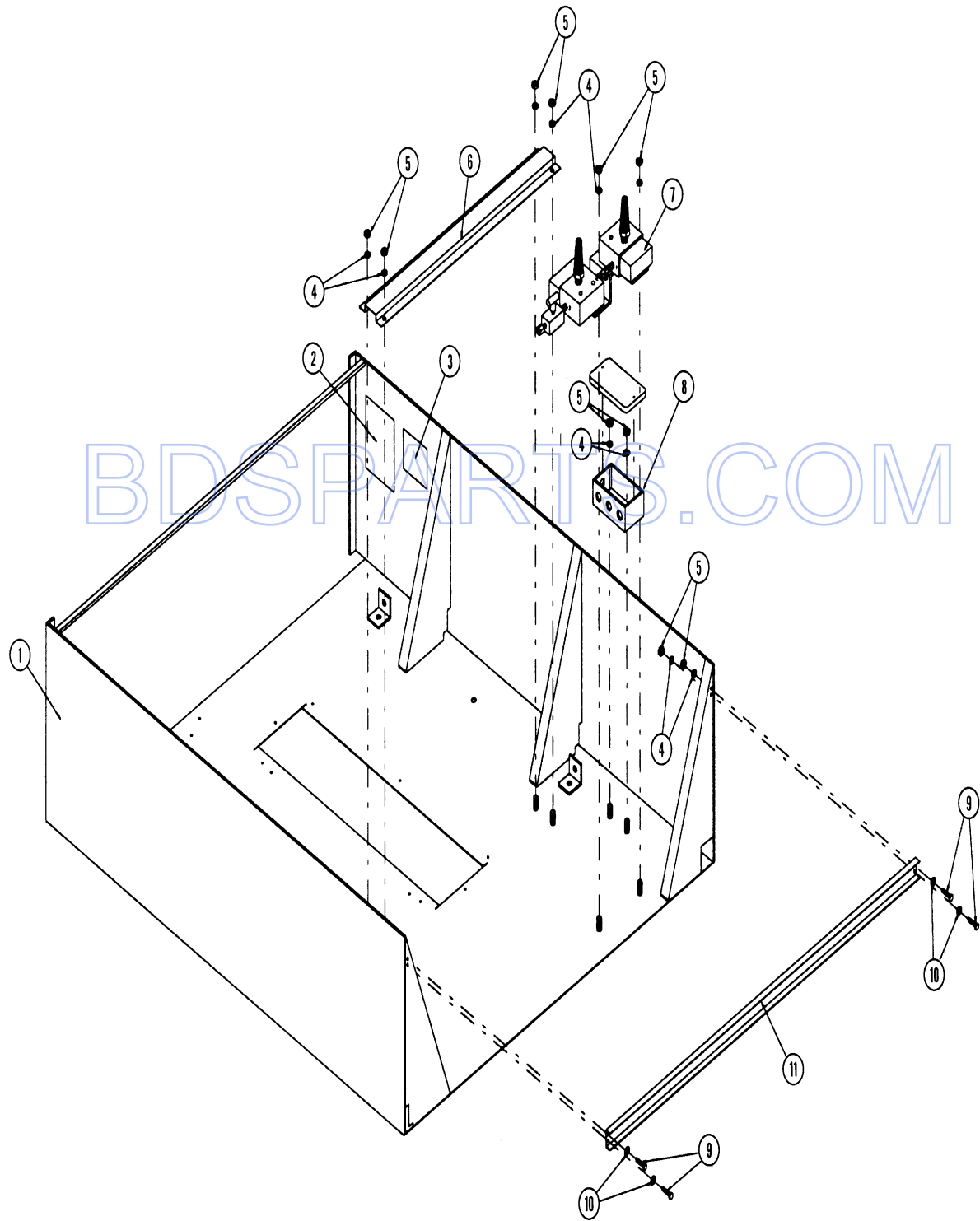

CD21-21

Section: TOP CONSOLE ASSEMBLY

No.	Part No.	Description	Series Qty
-	-----	NOT REQUIRED PART OR SEE NOTE Note: ORDER PARTS FROM AMERICAN DRYER CORP AT 508-678-9000.	0
1	A821085	TOP CONSOLE ASSEMBLY (ONLY) Note: TOP CONSOLE ASSEMBLY (ONLY) (SPECIFY COLOR WHEN ORDERING)	1
2	A112554	LABEL, PHASE 5 Note: (OPL PROGRAM LOCATION SUMMARY)	1
3	-----	NOT REQUIRED PART OR SEE NOTE Note: LABEL, DRYER DATA	0
4	A153007	WASHER, LOCK (1/4") Note: LOCK WASHER (1/4")	12
5	A152005	NUT, HEX (#16-3/8") Note: NUT, HEX (#1/4-20)	12
6	A332323	CHANNEL, WIRE (33")	1
7	A821105	VALVE ASSY. (ONLY) Note: (REFER TO PNEUMATIC VALVE ASSEMBLY SECTION)	1
8	A121105	COVER, JUNCTION BOX (ONLY)	1
8	A121104	BOX, JUNCTION (2" X 4") Note: (ONLY)	1
9	A150615	BOLT (#1/4-20 X 3/4")	4
10	A153018	WASHER, FLAT (1/4")	4
11	A332186	CHANNEL, CONTROL DOOR HINGE Note: (SPECIFY COLOR WHEN ORDERING)	1

BDSPARTS.COM

*Color Code (-)=Not Shown #=Series, Serial Prefix or Run No., N=Not Available

Section: PNEUMATIC VALVE ASSEMBLY

Model: MDG170P1HW

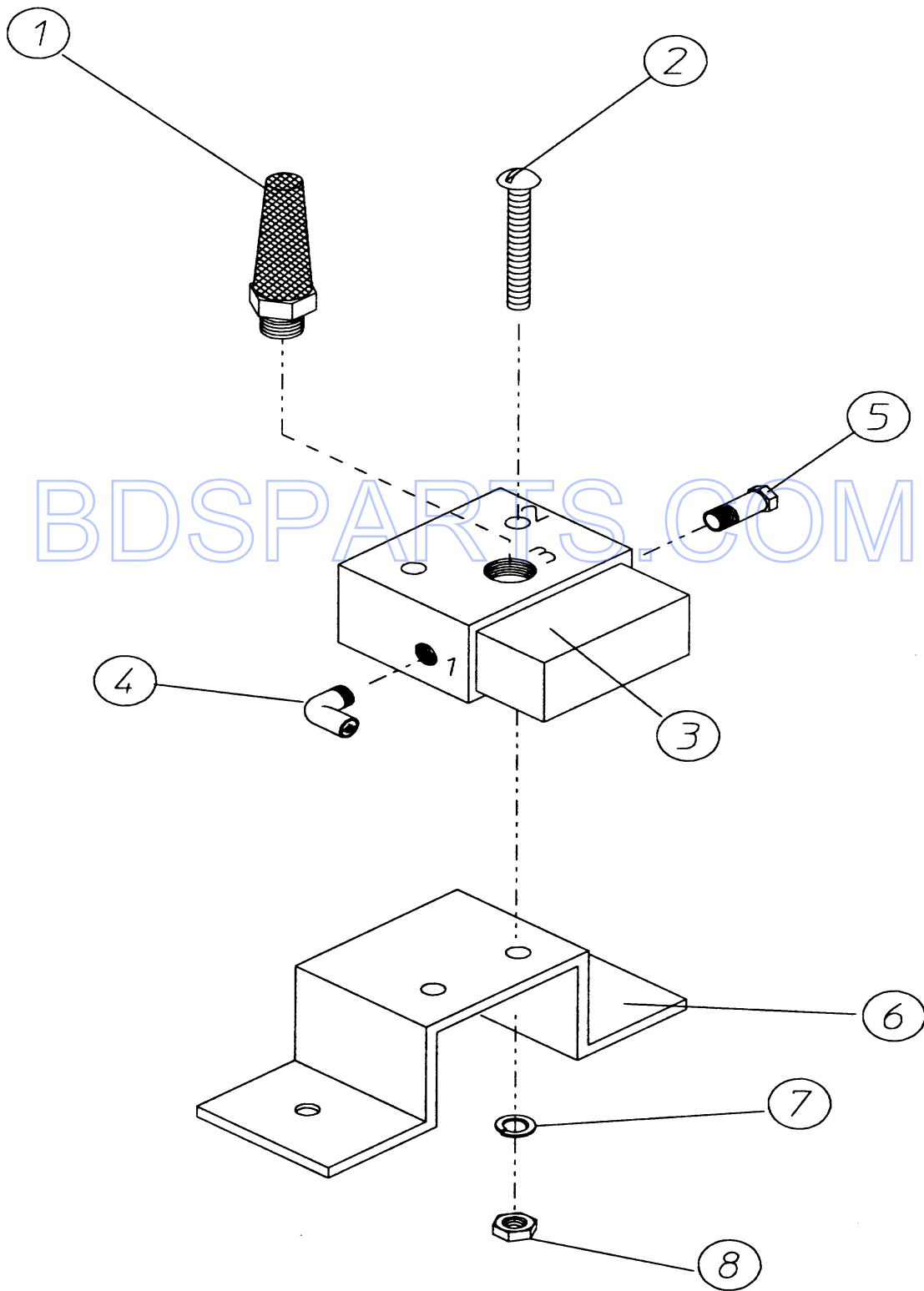

CD14-2

Section: PNEUMATIC VALVE ASSEMBLY

No.	Part No.	Description	Series	Qty
-	-----	NOT REQUIRED PART OR SEE NOTE Note: ORDER PARTS FROM AMERICAN DRYER CORP AT 508-678-9000.		0
1	A100520	SILENCER N.P.T. (1/8") ONLY		1
2	A150002	SCREW, MACHINE (RD.HD.) Note: SCREW, MACHINE (SLOTTED #6-32 X 1")		1
3	A100498	VALVE, MICRO (ONLY-3WAY) Note: VALVE, MICRO (ONLY-3WAY)		1
3	A821105	VALVE ASSY. (ONLY) Note: VALVE ASSEMBLY COMPLETE (INCLUDES 1 - 8)		1
4	A143268	ELBOW, STREET (1/8")		1
5	A100472	CONNECTOR (1/4" X 1/8")		1
6	A330987	BRACKET, MICRO VALVE SUPPORT Note: (ONLY)		1
7	A153010	WASHER, STAR (#6) Note: WASHER, STAR (#6)		1
8	A152000	NUT, HEX (#6-32) Note: NUT, HEX (#6-32)		1

BDSPARTS.COM

*Color Code (-)=Not Shown #=Series, Serial Prefix or Run No., N=Not Available

Section: BACKGUARD ASSEMBLY

Model: MDG170P1HW

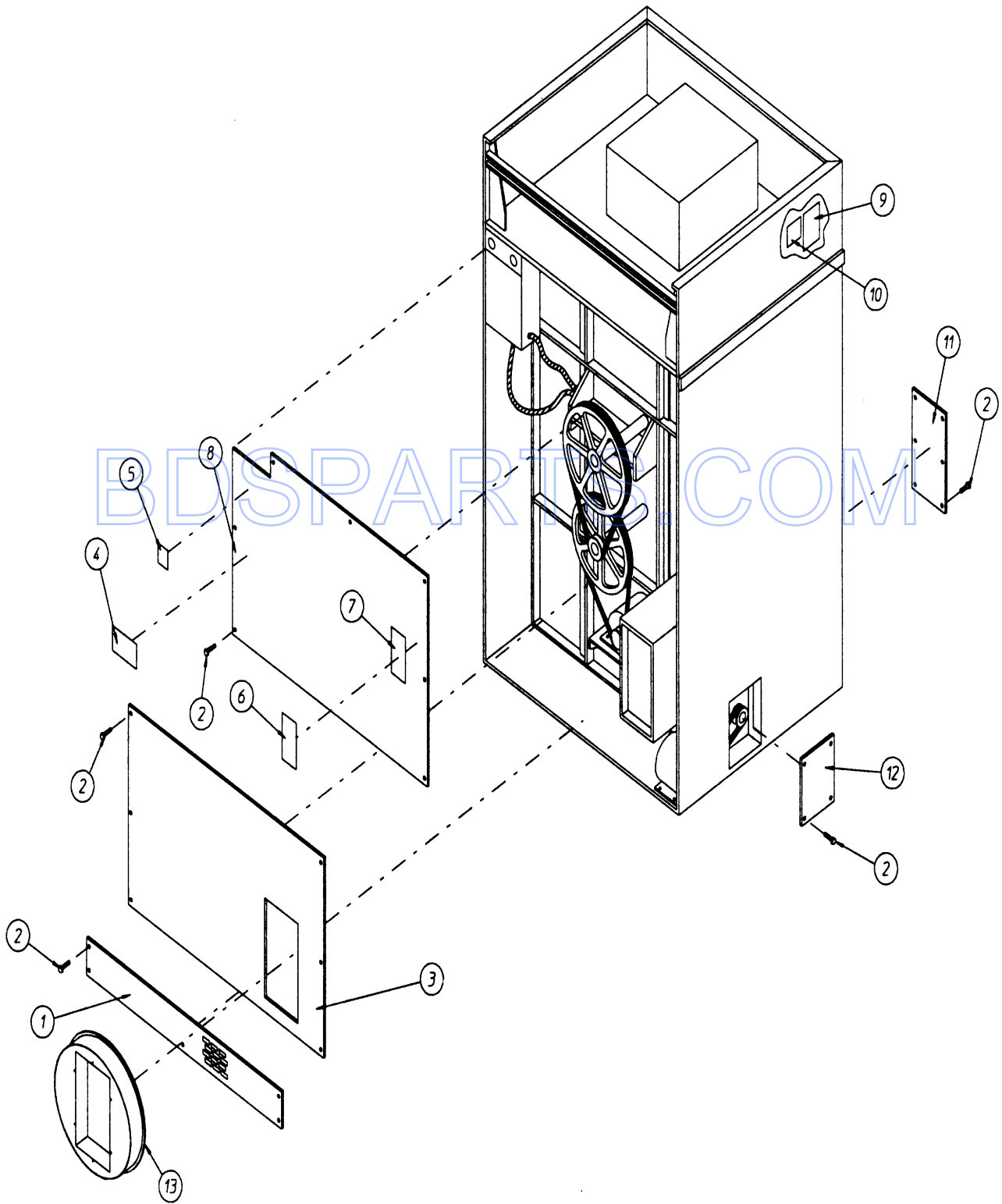

CD11-24

Section: BACKGUARD ASSEMBLY

No.	Part No.	Description	Series	Qty
-	-----	NOT REQUIRED PART OR SEE NOTE Note: ORDER PARTS FROM AMERICAN DRYER CORP AT 508-678-9000.		0
1	A332328	BOTTOM, BACKGUARD (ONLY) Note: BOTTOM, BACKGUARD (ONLY)		1
2	A150301	SCREW, TEK (#8-18 X 7/16 PH Note: SCREW, TEK (PH.PN.HD. #8-18 X 7/16")		28
3	A821096	MIDDLE, BACKGUARD (ONLY) Note: MIDDLE, BACKGUARD (ONLY)		1
4	A112014	LABEL, HIGH VOLTAGE (ONLY)		1
5	A112017	LABEL, NAME/ADDRESS/TELEPHONE Note: LABEL, NAME/ADDRESS/TELEPHONE (ONLY)		1
6	A112230	LABEL, INSTALLATION INSTRUCT. Note: (ONLY)		1
7	A112519	LABEL, ROUTINE MAINTENANCE Note: (ONLY)		1
8	A821095	TOP, BACKGUARD (ONLY)		1
9	A112554	LABEL, PHASE 5 Note: (OPL PROGRAM LOCATION SUMMARY)		1
10	-----	NOT REQUIRED PART OR SEE NOTE Note: LABEL, DRYER DATA		0
11	A332295	PANEL, ACCESS BLOWER HSG. FRT. Note: (SPECIFY COLOR WHEN ORDERING)		1
12	A332309	PANEL, ACCESS (SIDE) Note: (SPECIFY COLOR WHEN ORDERING)		1
13	A821092	TRANSITION PIECE ASSEMBLY Note: (SQUARE DUCT TO ROUND DUCT)		1

BDSPARTS.COM

*Color Code (-)=Not Shown #=Series, Serial Prefix or Run No., N=Not Available

Section: ADDITIONAL PARTS AVAILABLE

Model: MDG170P1HW

No image available

BDSPARTS.COM

NOIMAGE

Section: ADDITIONAL PARTS AVAILABLE

No.	Part No.	Description	Series	Qty
-	-----	NOT REQUIRED PART OR SEE NOTE Note: ORDER PARTS FROM AMERICAN DRYER CORP AT 508-678-9000.		0
1	A112027	LABEL "WATER WASHED FABRICS"		1
2	A112098	LABEL "ROTATION"		1
3	A112040	LABEL "LINT COMPARTMENT"		1
4	A112041	LABEL "CAUTION-EXHAUSTED" Note: LABEL "CAUTION-EXHAUSTED"		1
6	A121012	CONNECTOR, STRAIGHT (3/8")		1
7	A120111	CONNECTOR, LIQUIDTITE (1/2")		1
8	A120400	INSULATOR, RED JACKET (3/8")		1
9	A120500	CLIP, JIFFY (3/8")		1
10	A120600	GREENFIELD (3/8")		1
11	A120800	CONNECTOR, IN-LINE (1/4") Note: CONNECTOR, IN-LINE (1/4")		1
12	A120802	CONNECTOR, RED BUTT		1
13	A120902	NUT, WIRE (#74B)		1
14	A120903	NUT, WIRE (CRIMP-ON)		1
15	A120904	NUT, RED WIRE		1
16	A121014	TERMINAL, INSULATED (1/4 FEM.)		1
17	A121499	TIE, HARNESS (4")		1
18	A121500	TIE, HARNESS (7")		1
19	A122804	MANOMETER (15") Note: (WATER COLUMN TEST GAUGE)		1
20	A404500	PAINT, TOUCH-UP (ALM. AEROSOL) Note: PAINT, TOUCH-UP (ALM.) (BRUSH-IN-CAP BOTTLE)		1
21	A404502	PAINT, TOUCH-UP (WHT. AEROSOL) Note: PAINT, TOUCH-UP (WHT.) (BRUCH-IN-CAP BOTTLE)		1
22	A404506	PAINT, TOUCH-UP (ALM.) Note: PAINT, TOUCH-UP (ALM.) ("B" BRUSH-IN-CAP BOTTLE)		1
23	A404507	PAINT, TOUCH-UP (CRNFLWR BLUE) Note: PAINT, TOUCH-UP (CRNFLWR BLUE)(BRUSH-IN-CAP BOTTLE)		1
24	A880200	TERMINAL KIT (ELECTRICAL) Note: (ASSORTMENT)		1

*Color Code (-)=Not Shown #=Series, Serial Prefix or Run No., N=Not Available

Section: STEP-DOWN TRANSFORMER APPL. LISTING

Model: MDG170P1HW

No image available

BDSPARTS.COM

NOIMAGE

Section: STEP-DOWN TRANSFORMER APPL. LISTING

No.	Part No.	Description	Series	Qty
-	-----	NOT REQUIRED PART OR SEE NOTE Note: ORDER PARTS FROM AMERICAN DRYER CORP AT 508-678-9000.		0
1	A132059	TRANSFORMER Note: TRANSFORMER (380V, WIRE SVC. 3 OR 4)		1
2	A132062	TRANSFORMER Note: (416V, WIRE SVC. 3 OR 4)		1
3	A132056	TRANSFORMER Note: (440V, WIRE SVC. 3 OR 4)		1
4	A132053	TRANSFORMER Note: (460/480V, WIRE SVC. 3 OR 4)		1
5	A132050	TRANSFORMER Note: (575V, WIRE SVC. 3)		1

BDSPARTS.COM

*Color Code (-)=Not Shown #=Series, Serial Prefix or Run No., N=Not Available

