

DRYER

Repair Parts List

MODEL NUMBER
MDG50PNHWQ

When requesting service or ordering parts, always provide the following information:

- Product Type
- Part Number
- Model Number
- Part Description

MAYTAG®

©2005 Maytag Services

Section: CONTROL DOOR

Model: MDG50PNHWQ

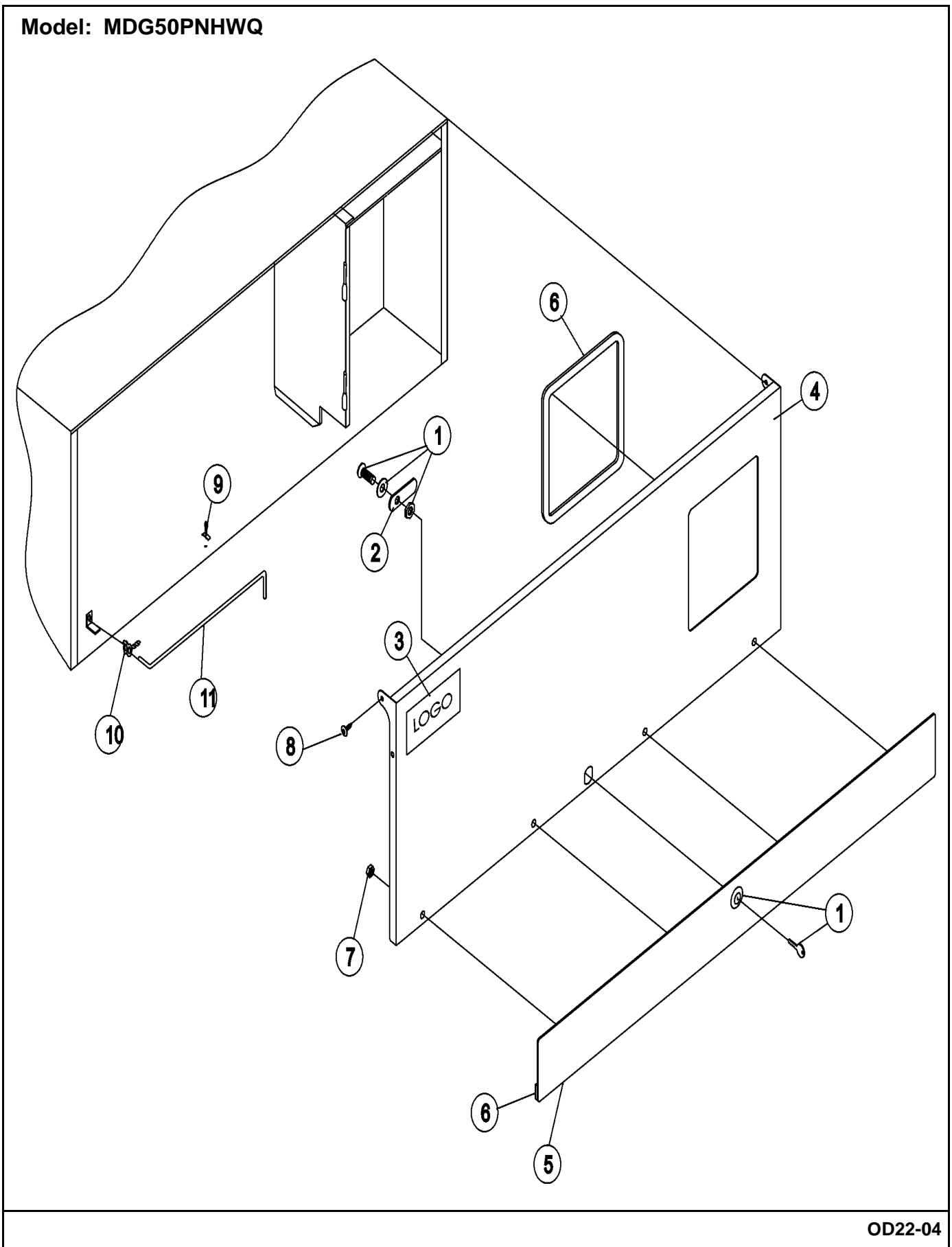

OD22-04

Section: CONTROL DOOR

No.	Part No.	Description	Series	Qty
-	A000000	ORDER PART FROM AMERICAN DRYER Note: #508-678-9000	10	1
1	A160017	LOCK, SPECIAL DUMMY	10	1
2	A160016	CAM, LOCK	10	1
3	A112353	LOGO	10	1
4	A883713	CONTROL DOOR BSQ	10	1
5	A883476	STRIP, TRIM BLK	10	1
6	A117604	TAPE, FOAM (SOLD IN FEET)	10	6
7	A152014	NUT, FREE SPIN WASH (#20-1/4)	10	4
8	A150317	3/4" TORX SCREW	10	2
9	A102603	CATCH, ROD SUPPORT-CTRL. DOOR	10	1
10	A102601	CLIP, ROD RETAINER-CTRL. DOOR	10	1
11	A102502	ROD, SUPPORT (CONTROL DOOR)	10	1

*Color Code (-)=Not Shown #=Series, Serial Prefix or Run No., N=Not Available

Section: CONTROL PANEL (MICROPROCESSOR)

Model: MDG50PNHWQ

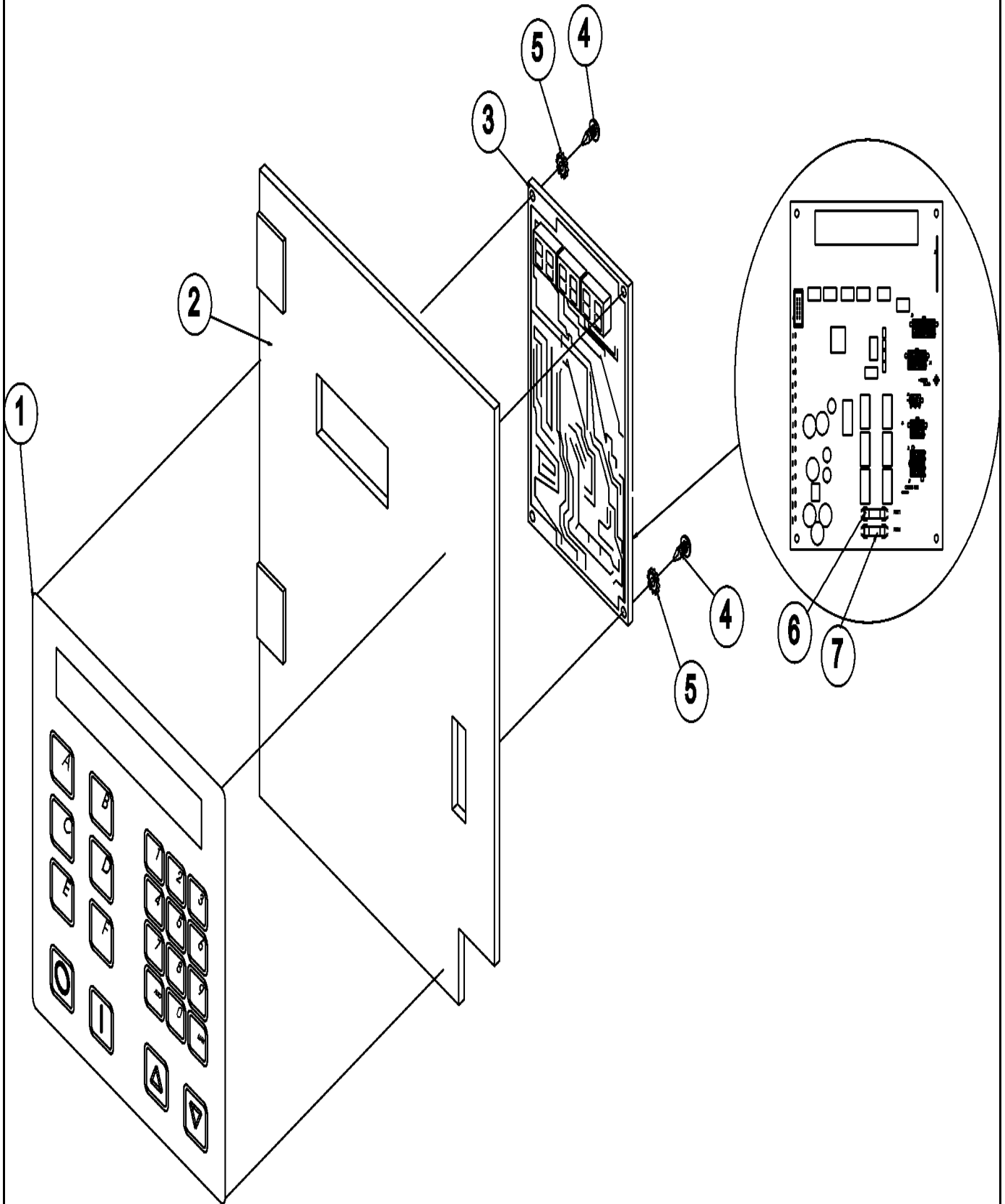

OD11-02

Section: CONTROL PANEL (MICROPROCESSOR)

No.	Part No.	Description	Series	Qty
-	A000000	ORDER PART FROM AMERICAN DRYER Note: #508-678-9000	10	1
1	A112571	KEYBOARD, PHASE 7 OPL	10	1
1	A112577	KEYBOARD, PHASE 7 OPL	26	1
2	A850984	PANEL, MICROPRO PHASE 7 ONLY	10	1
-	A822767	CONTROL PANEL, COMPLETE	10	1
3	A137247	MICROPROCESSOR, PHASE 7 OPL	10	1
3	A137243	MICROPROCESSOR, PHASE 7 OPL	12	1
4	A150005	SCREW, PHILL (6-32 X 1/4")RND	10	2
5	A153010	WASHER, STAR (#6)	10	2
6	A136016	FUSE, 5 AMP	10	1
7	A136097	FUSE, 500MA FUSE	10	1

*Color Code (-)=Not Shown #=Series, Serial Prefix or Run No., N=Not Available

Section: CONTROL BOX (MICROPROCESSOR)

Model: MDG50PNHWQ

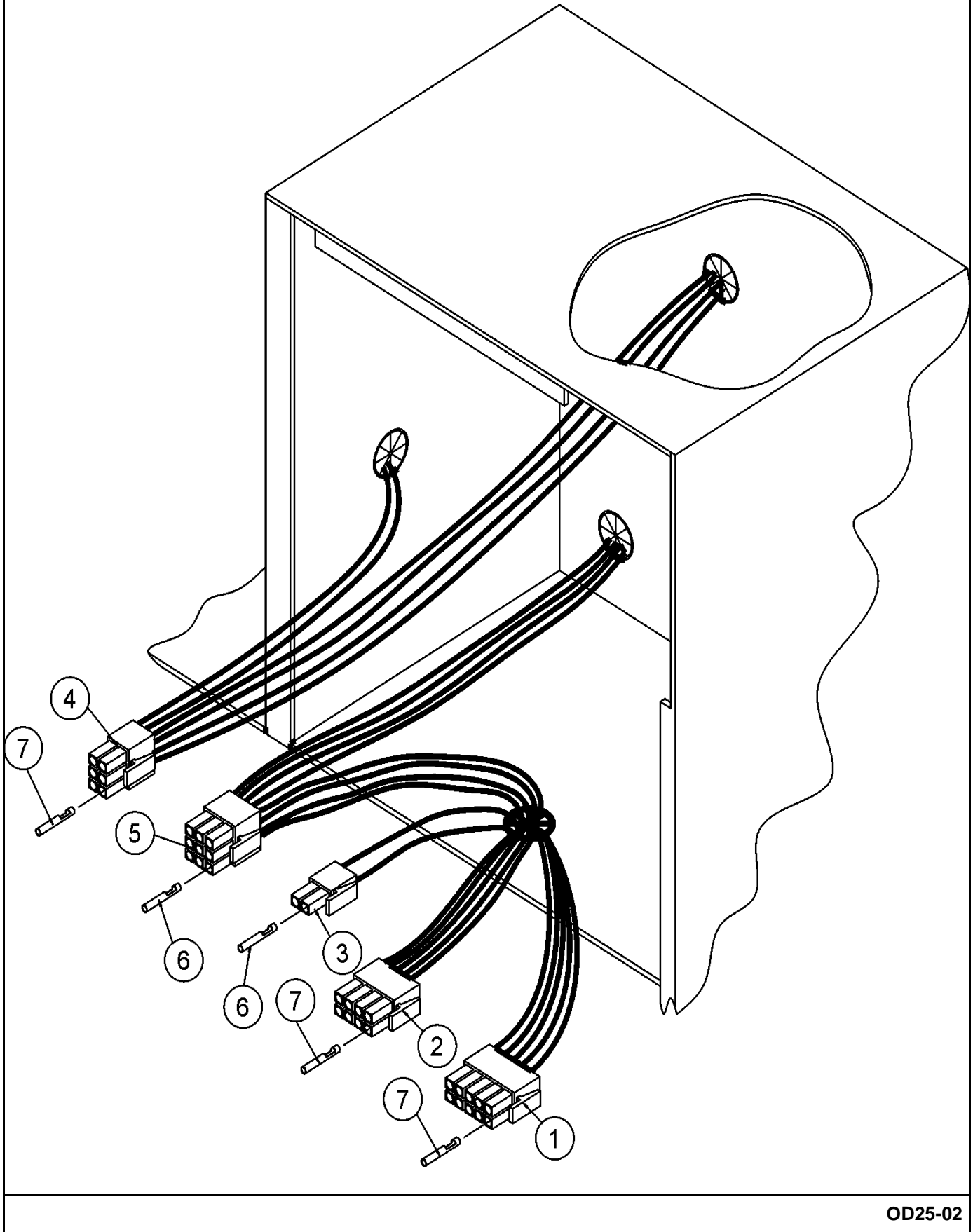

OD25-02

Section: CONTROL BOX (MICROPROCESSOR)

No.	Part No.	Description	Series	Qty
-	A000000	ORDER PART FROM AMERICAN DRYER Note: #508-678-9000	10	1
1	A122681	CONNECTOR, 10 PIN	10	1
2	A122676	CONNECTOR, 8 PIN	10	1
3	A122646	CONNECTOR, 2 PIN	10	1
4	A122683	CONNECTOR, 6 PIN	10	1
5	A122640	CONNECTOR, 9 PIN	10	1
6	A122706	SOCKETS	10	11
7	A122669	TERMINAL, FEMALE CRIMP	10	24

*Color Code (-)=Not Shown #=Series, Serial Prefix or Run No., N=Not Available

Section: FRONT PANEL

Model: MDG50PNHWQ

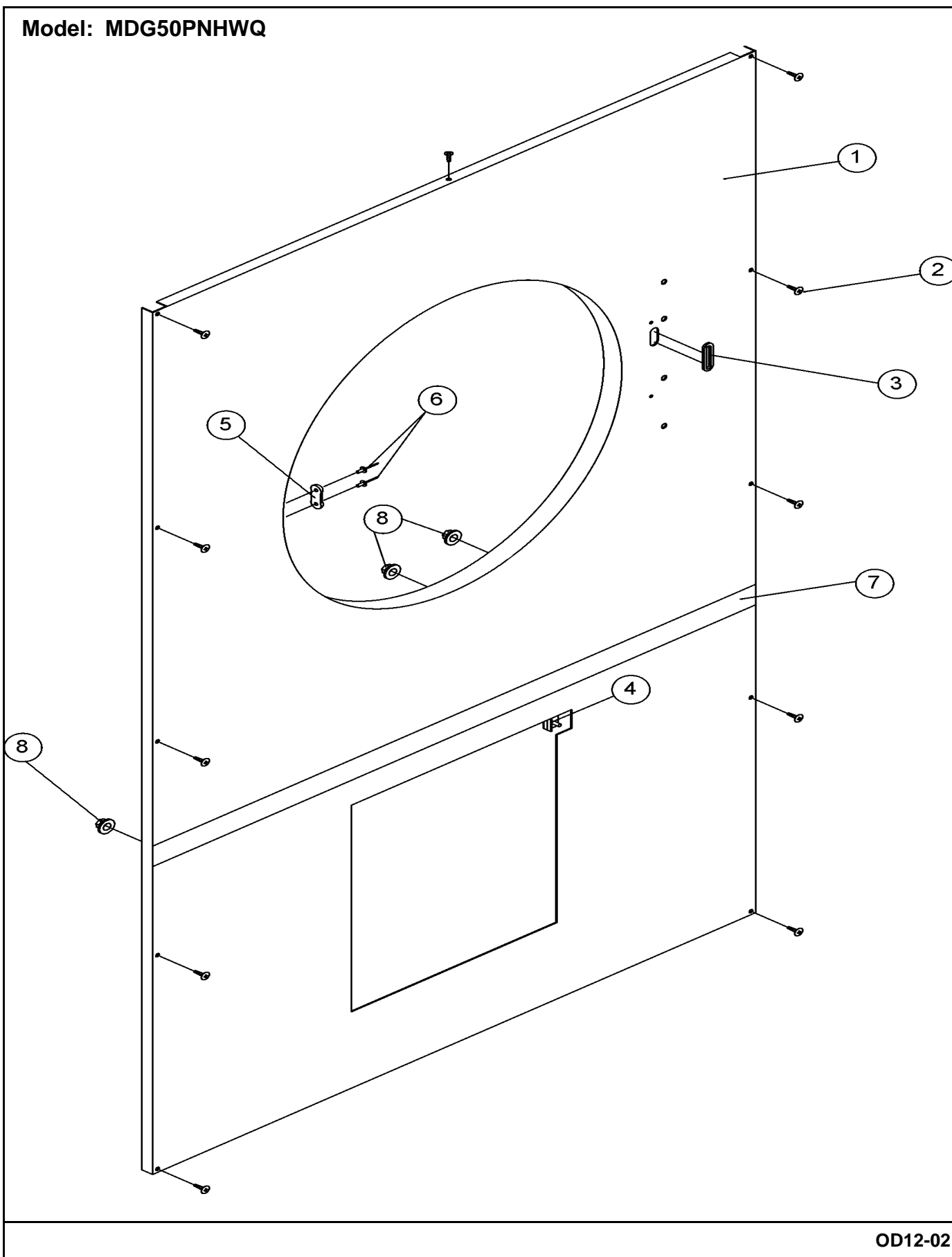

OD12-02

Section: FRONT PANEL

No.	Part No.	Description	Series	Qty
-	A000000	ORDER PART FROM AMERICAN DRYER Note: #508-678-9000	10	1
1	A883516	PANEL, FRONT RIGHT HAND BSQ	10	1
2	A150309	SCREW, CRIMPTITE	10	11
3	A121405	GROMMET, RUBBER	10	1
4	A122116	SWITCH, LINT BASKET	10	1
5	A170330	LATCH, DOOR (FRICTION)	10	1
6	A154215	RIVET, POP (5/32")	10	2
7	A883715	TRIM, FRONT PANEL BLK	10	1
8	A152014	NUT, FREE SPIN WASH (#20-1/4)	10	5

*Color Code (-)=Not Shown #=Series, Serial Prefix or Run No., N=Not Available

Section: DOOR SWITCH

Model: MDG50PNHWQ

UPPER MAIN DOOR SWITCH

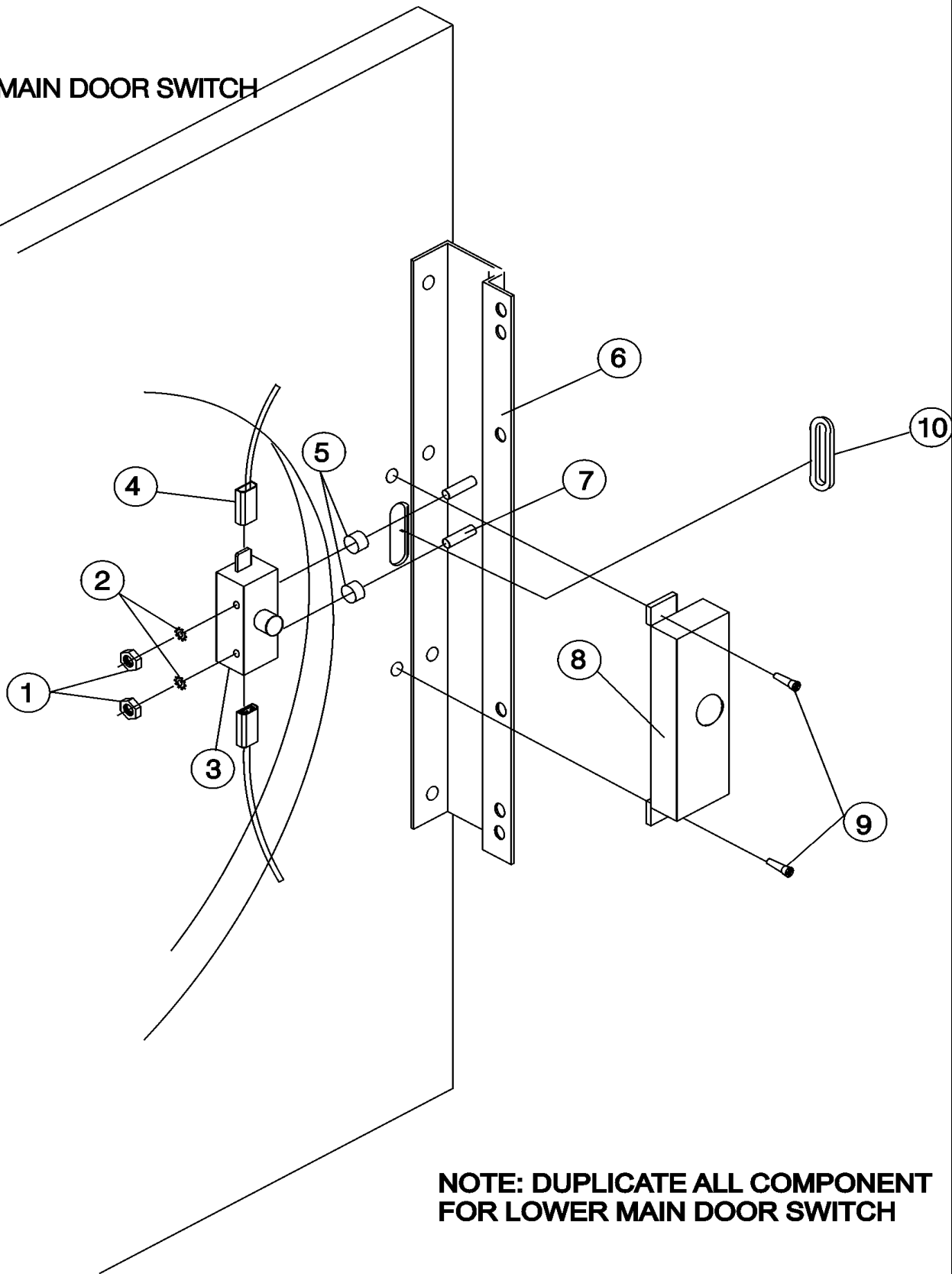

NOTE: DUPLICATE ALL COMPONENT FOR LOWER MAIN DOOR SWITCH

Section: DOOR SWITCH

No.	Part No.	Description	Series	Qty
-	A000000	ORDER PART FROM AMERICAN DRYER Note: #508-678-9000	10	1
1	A152013	NUT, HEX (#6-32)	10	1
2	A153008	WASHER, SPLIT LOCK (#6)	10	2
3	A137005	SWITCH, DOOR (SINGLE POLE)	10	1
4	A121028	TERMINAL, 1/4" INSUL. (FEMALE)	10	2
5	A154281	SPACER, NYLON (3/8")	10	2
6	A801524	BLACK DOOR HINGE	10	1
7	A153576	SELF-CLINCHING STUD #6 32X1	10	2
8	A313218	HOUSING, MAIN DOOR SWITCH	10	1
9	A150201	SCREW, MACHINE (#10-32 X 1/4")	10	2
10	A121405	GROMMET, RUBBER	10	1

*Color Code (-)=Not Shown #=Series, Serial Prefix or Run No., N=Not Available

Section: MAIN DOOR

Model: MDG50PNHWQ

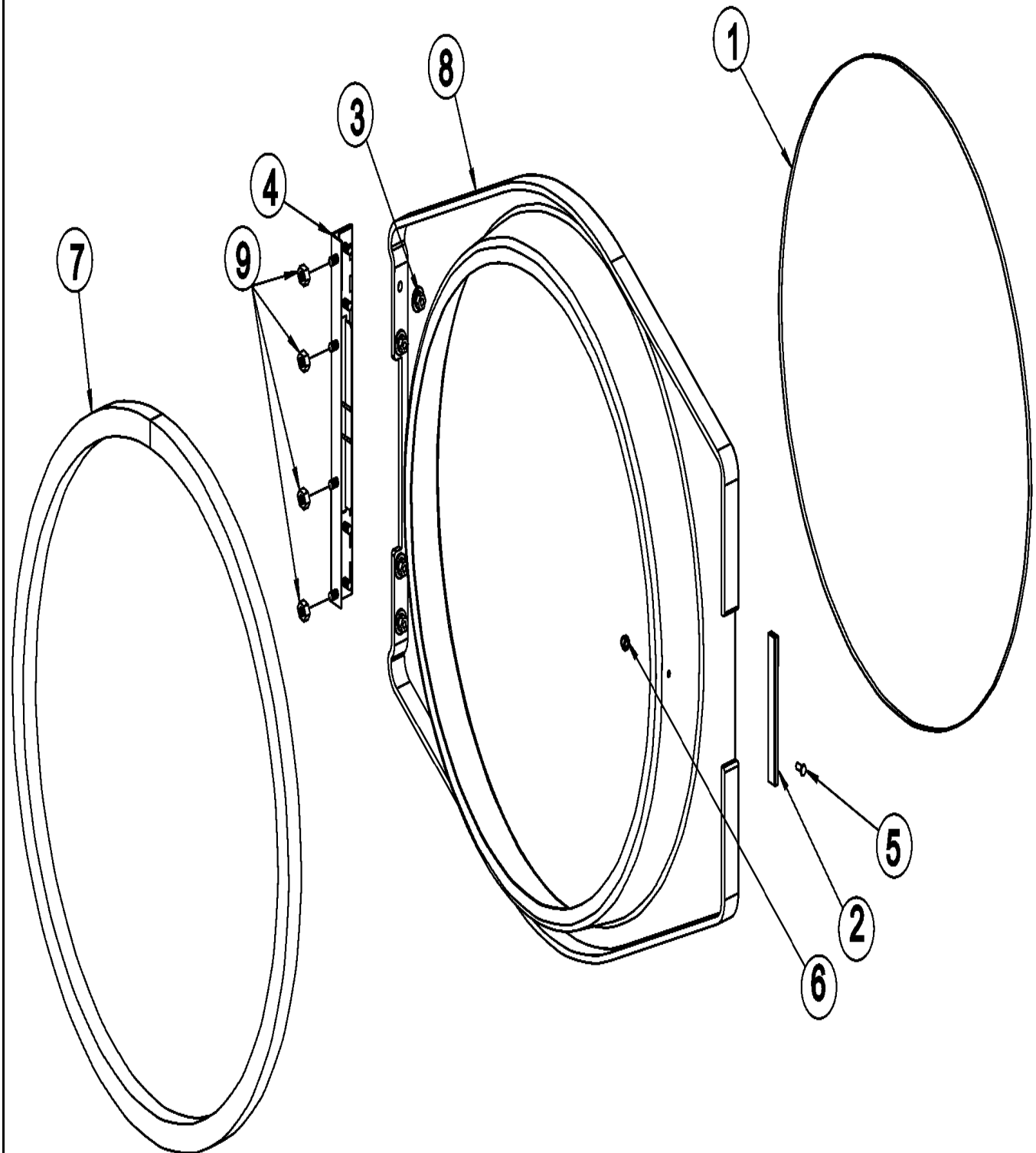

OD10-01

Section: MAIN DOOR

No.	Part No.	Description	Series	Qty
-	A000000	ORDER PART FROM AMERICAN DRYER Note: #508-678-9000	10	1
-	A170731	BLACK GLASS ADHESIVE (10.3 OZ)	10	1
1	A102210	GLASS, DOOR (20-7/16" ONLY)	10	1
2	A102328	HANDLE EDGE	10	1
3	A152014	NUT, FREE SPIN WASH (#20-1/4)	10	4
4	A801524	BLACK DOOR HINGE	10	1
5	A150120	LATCH SCREW	10	1
6	A151010	BLACK ACORN NUT	10	1
7	A102349	GASKET, DOOR	10	1
8	A882991	BLACK MAIN DOOR ASSY.	10	1
9	A152014	NUT, FREE SPIN WASH (#20-1/4)	10	4

*Color Code (-)=Not Shown #=Series, Serial Prefix or Run No., N=Not Available

Section: LINT DRAWER/SWITCH

Model: MDG50PNHWQ

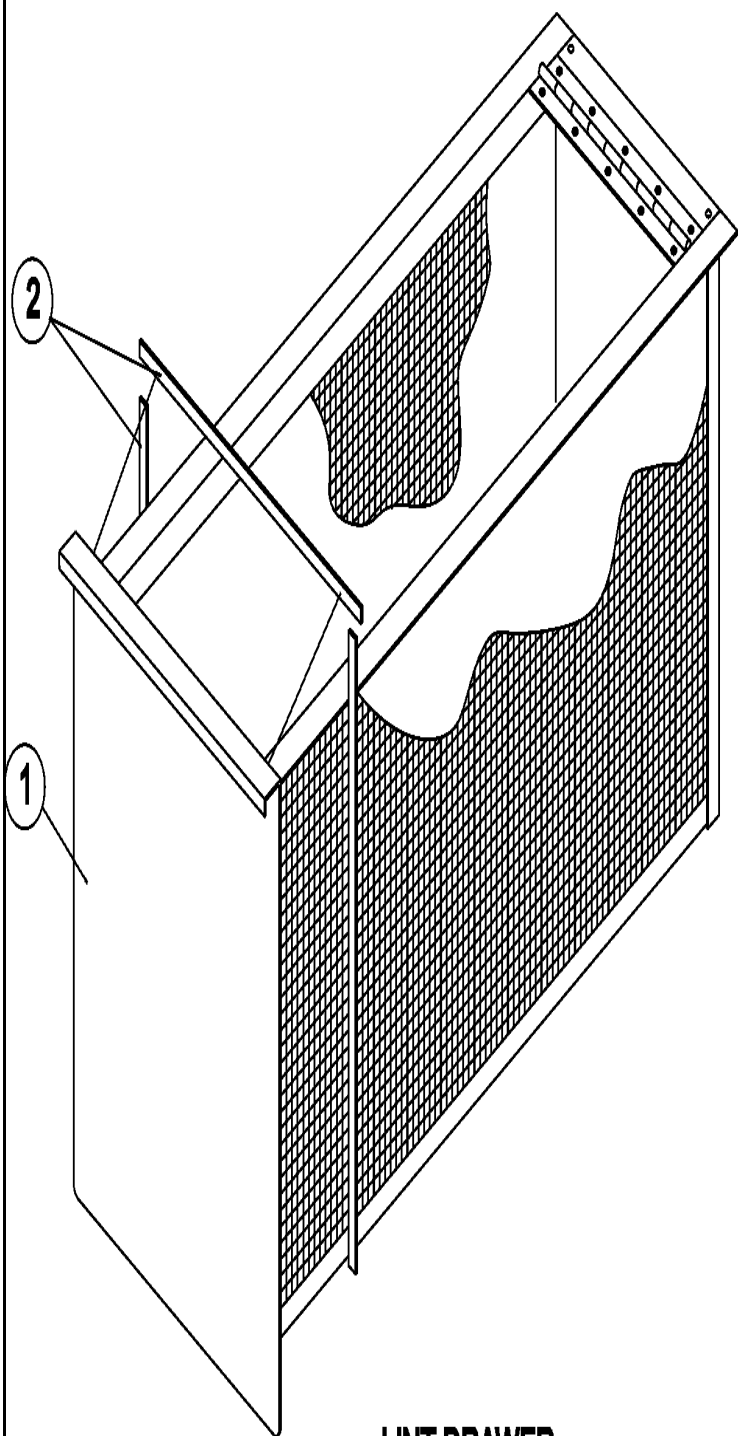

LINT DRAWER

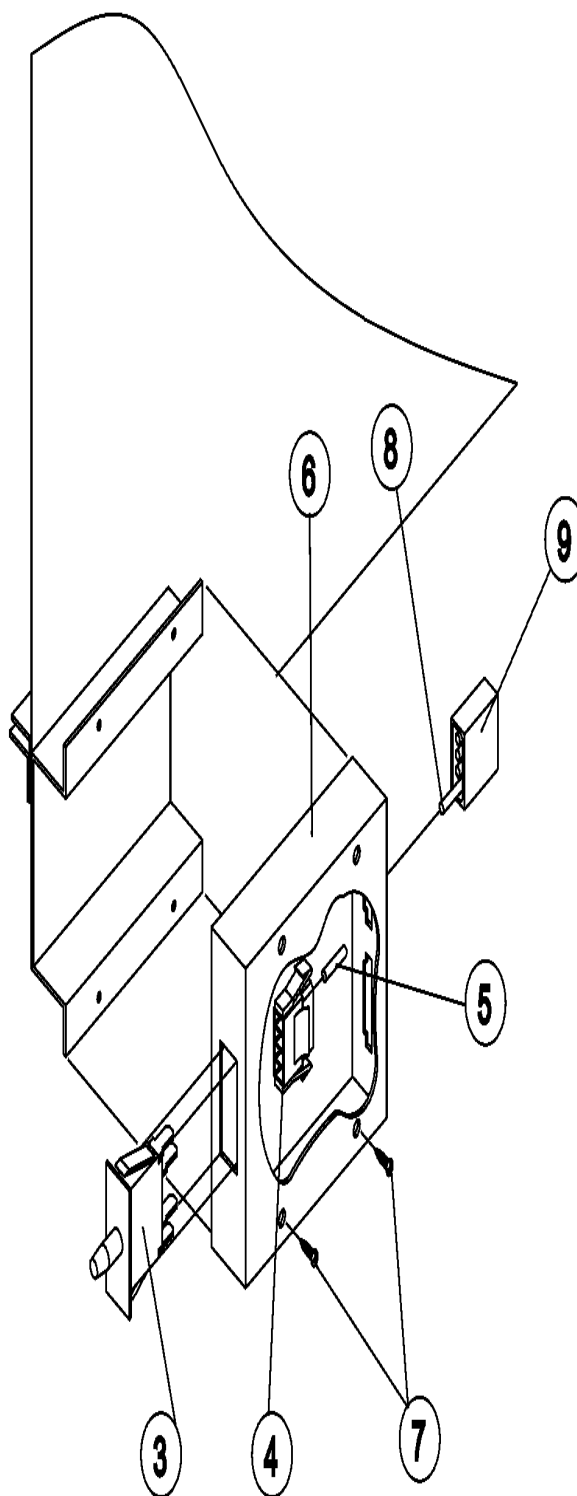

LINT DRAWER SWITCH ASSY

OD16-05

Section: LINT DRAWER/SWITCH

No.	Part No.	Description	Series	Qty
-	A000000	ORDER PART FROM AMERICAN DRYER Note: #508-678-9000	10	1
1	A883717	LINT DRAWER BSQ	10	1
2	A117604	TAPE, FOAM (SOLD IN FEET)	10	7
3	A122116	SWITCH, LINT BASKET	10	1
4	A122605	CONNECTOR, 4-PIN SOCKET	10	1
-	A122801	TOOL, EXTRACTION (PIN/SOCKET)	10	1
5	A122701	TERMINAL, SOCKET (ONLY)	10	2
-	A818087	SWITCH BOX, LINT DRAWER ASSY	10	1
6	A304136	SWITCH BOX, COVER ONLY	10	1
7	A150301	SCREW, TEK (#8-18 X 7/16 PH)	10	2
8	A122700	TERMINAL, PIN	10	2
9	A122604	CONNECTOR (4 PIN)	10	1

*Color Code (-)=Not Shown #=Series, Serial Prefix or Run No., N=Not Available

Section: TUMBLER SUPPORT

Model: MDG50PNHWQ

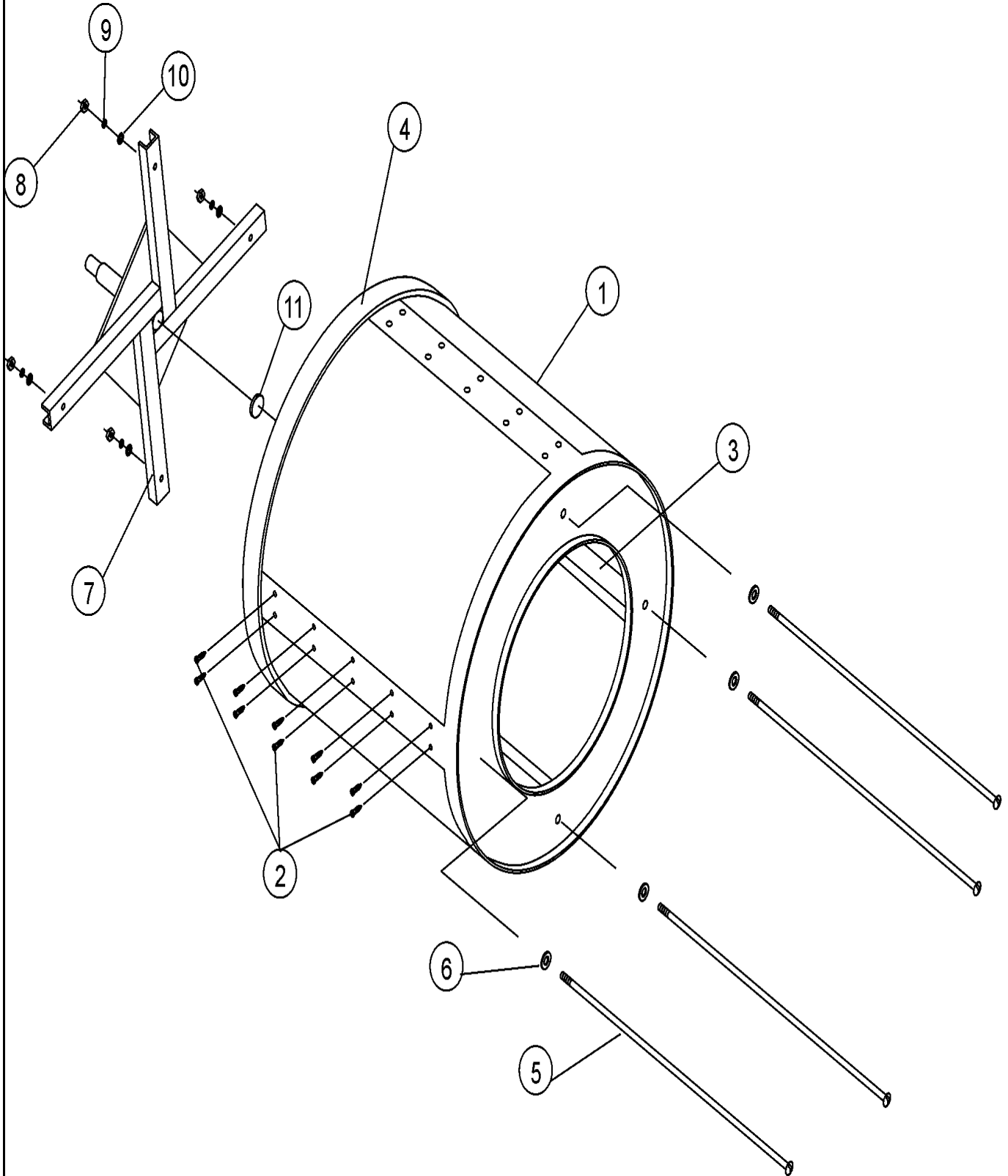

OD27-05

Section: TUMBLER SUPPORT

No.	Part No.	Description	Series	Qty
-	A000000	ORDER PART FROM AMERICAN DRYER Note: #508-678-9000	10	1
1	A880837	TUMBLER, GALVANIZED	10	1
-	A880838	TUMBLER, GALVANIZED COMPLETE	10	1
2	A150313	SCREW	10	40
-	A150429	TROX HAND DRIVER	10	1
3	A301302	TUMBLER RIB ONLY(LOW RIB)	10	2
3	A301311	TAPERED TUMBLER BAFFLE RIB(HI)	10	2
-	A401010	ADHESIVE, FELT COLLAR #847	10	1
4	A116001	FELT COLLAR	10	1
5	A100903	TIE ROD	10	4
6	A153004	WASHER, FLAT (3/8")	10	4
7	A800616	SUPPORT, TUMBLER	10	1
8	A152005	NUT, HEX (#16-3/8")	10	4
9	A153005	WASHER, LOCK (3/8")	10	4
10	A153004	WASHER, FLAT (3/8")	10	4
11	A115986	PAD, FELT TUMBLER 1/4X2	10	1

*Color Code (-)=Not Shown #=Series, Serial Prefix or Run No., N=Not Available

Section: SENSOR BRACKET

Model: MDG50PNHWQ

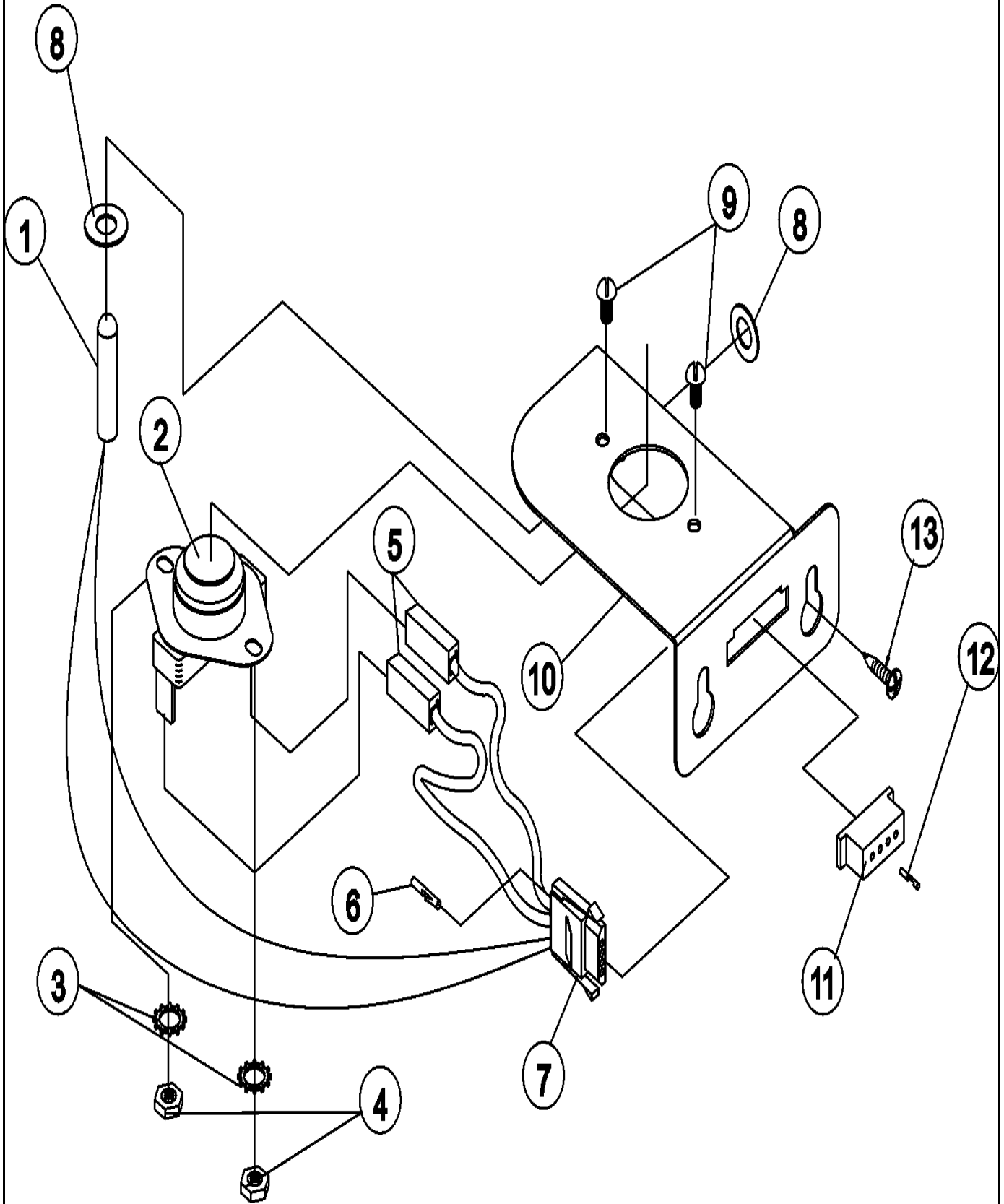

OD28-01

Section: SENSOR BRACKET

No.	Part No.	Description	Series	Qty
-	A000000	ORDER PART FROM AMERICAN DRYER Note: #508-678-9000	10	1
1	A880251	PROBE ASSY., TEMP. (1/4")	10	1
2	A130103	THERMOSTAT (225 DEGREE)	10	1
3	A153010	WASHER, STAR (#6)	10	2
4	A152000	NUT, HEX (#6-32)	10	2
5	A121028	TERMINAL, 1/4" INSUL. (FEMALE)	10	2
6	A122701	TERMINAL, SOCKET (ONLY)	10	4
7	A122605	CONNECTOR, 4-PIN SOCKET	10	1
8	A154007	FASTENER, PUSH-ON (1/4")	10	2
9	A150005	SCREW, PHILL (6-32 X 1/4")RND	10	2
10	A322214	BRACKET, SENSOR	10	1
-	A817046	SENSOR BRACKET ASSY.	10	1
11	A122604	CONNECTOR (4 PIN)	10	1
12	A122700	TERMINAL, PIN	10	4
13	A150301	SCREW, TEK (#8-18 X 7/16 PH	10	2

*Color Code (-)=Not Shown #=Series, Serial Prefix or Run No., N=Not Available

Section: TUMBLER BEARING

Model: MDG50PNHWQ

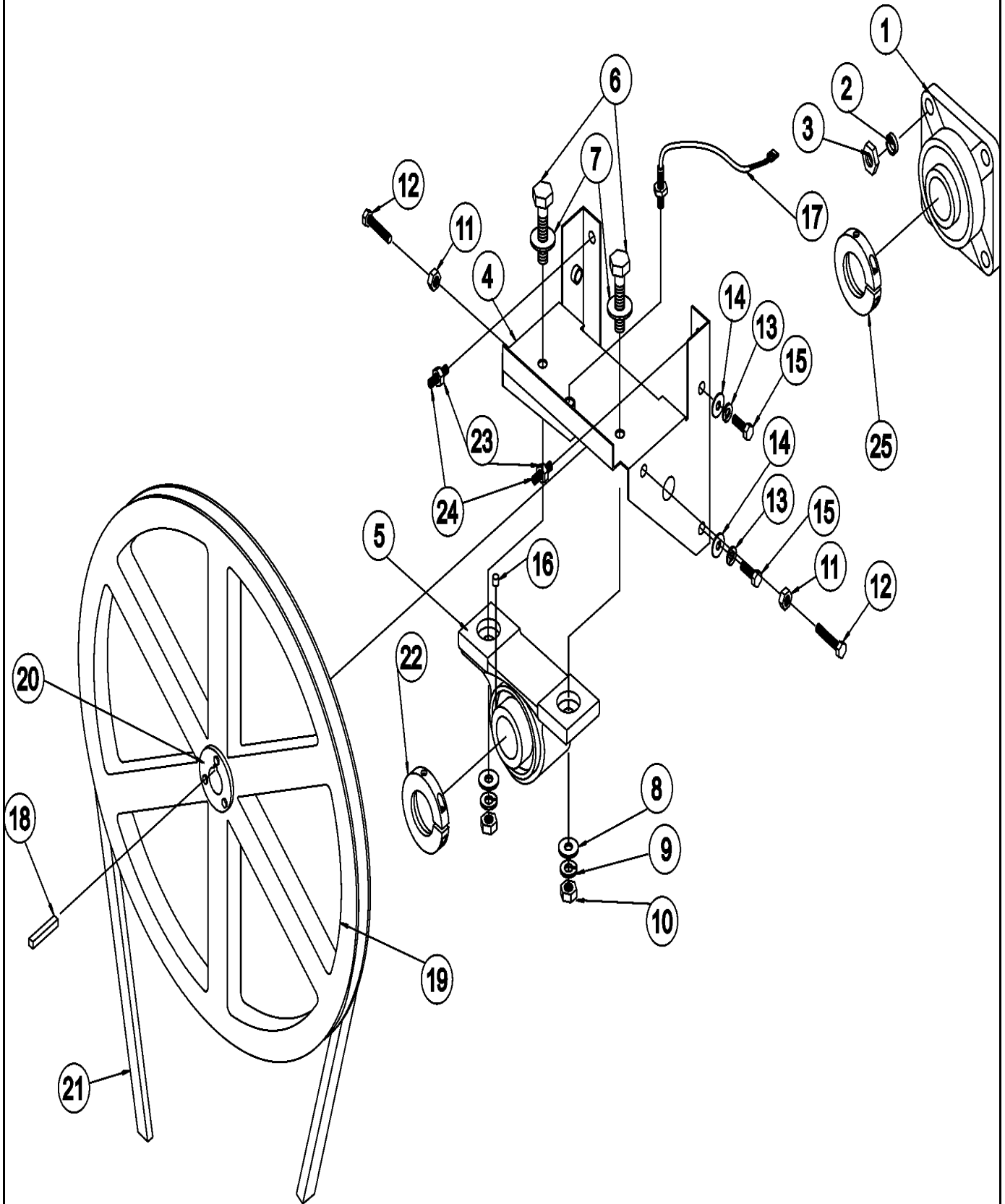

OD27-03

Section: TUMBLER BEARING

No.	Part No.	Description	Series	Qty
-	A000000	ORDER PART FROM AMERICAN DRYER Note: #508-678-9000	10	1
1	A883735	BEARING, FLANGE	10	1
2	A153025	LOCK WASHER (9/16")	10	4
3	A152050	HEX NUT (#9/16-12)	10	4
4	A882543	BEARING SUPPORT ONLY	10	1
-	A883736	BEARING, PILLOW BLOCK, COMPLETE	10	1
5	A883710	BEARING, PILLOW BLOCK	10	1
6	A150601	BOLT, MACHINE	10	2
7	A153004	WASHER, FLAT (3/8")	10	2
8	A153004	WASHER, FLAT (3/8")	10	2
9	A153005	WASHER, LOCK (3/8")	10	2
10	A153005	WASHER, LOCK (3/8")	10	2
11	A152004	NUT, HEX (#18-5/16)	10	2
12	A150621	BOLT, MACHINE (#18-5/16X1 1/2)	10	2
13	A153002	WASHER, LOCK (5/16")	10	4
14	A153004	WASHER, FLAT (3/8")	10	6
15	A150501	BOLT, MACHINE (#18-5/16 X 3/4)	10	1
16	A102120	SINTERED 8 MAGNET	10	1
17	A883386	SENSOR, ROTATIONAL	10	1
18	A100735	SHAFT KEY (FOR TAPER LOCK HUB)	10	1
19	A101100	PULLEY (18")	10	1
20	A101110	BUSHING	10	1
21	A100100	V-BELT	10	1
22	A100270	COLLAR, GRIPLOCK	10	1
23	A150610	SCREW, SET (#18-5/16" X 1 1/2)	10	2
24	A152004	NUT, HEX (#18-5/16)	10	2
25	A100272	COLLAR, GRIPLOCK	10	1

*Color Code (-)=Not Shown #=Series, Serial Prefix or Run No., N=Not Available

Section: IDLER BEARING

Model: MDG50PNHWQ

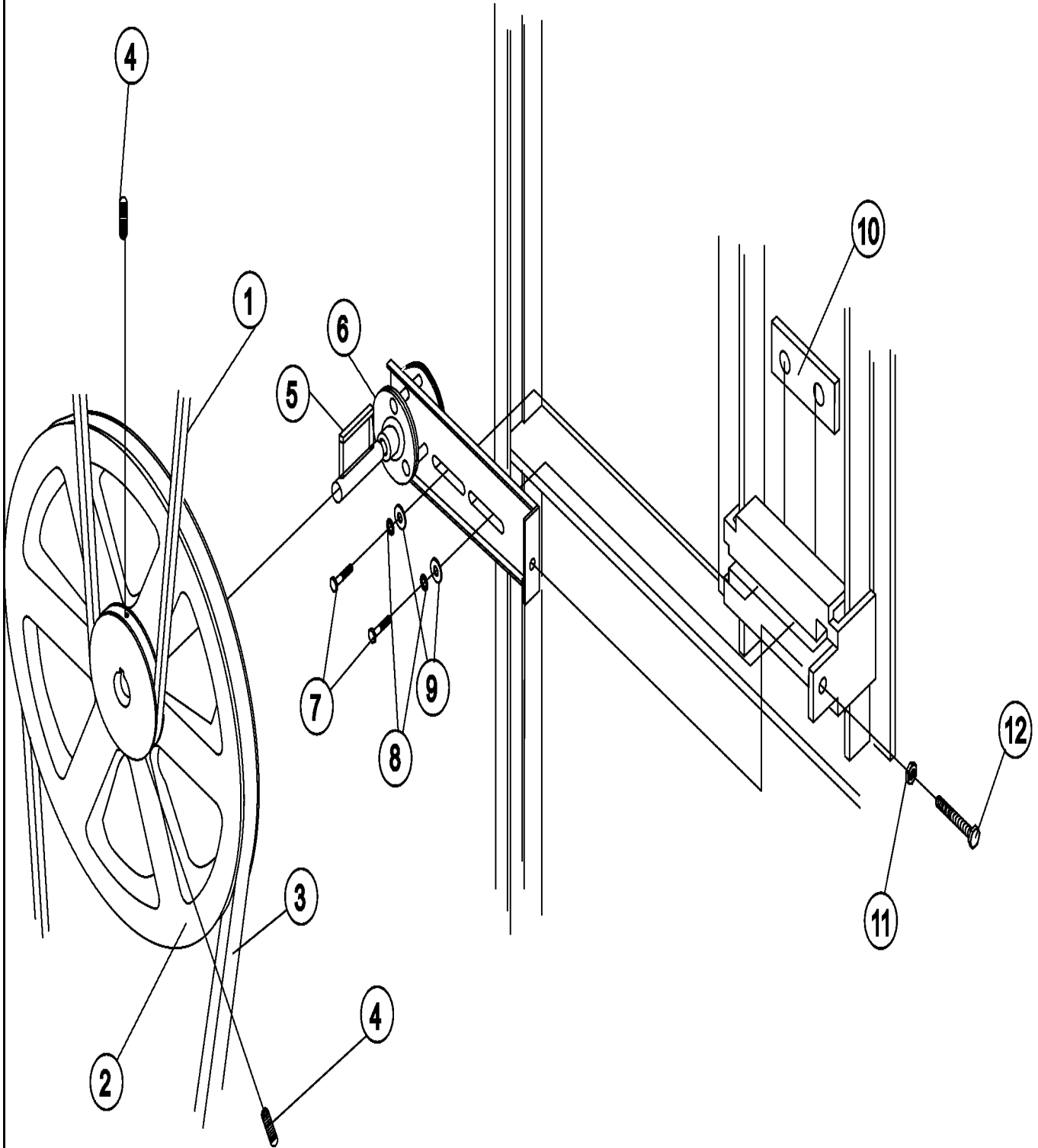

OD27-04

Section: IDLER BEARING

No.	Part No.	Description	Series	Qty
-	A000000	ORDER PART FROM AMERICAN DRYER Note: #508-678-9000	10	1
1	A100100	V-BELT	10	1
2	A101129	PULLEY W/KEY(9" X 2 1/2")	10	1
3	A100105	V-BELT	10	1
4	A154301	SCREW, ALLEN (#18-5/16 X 5/16)	10	1
5	A100705	KEY (3/16" X 3/16" X 1-3/8")	10	1
6	A882576	BEARING, IDLER COMPLETE	10	1
7	A150617	BOLT, MACHINE (#16-3/8 X 1")	10	2
8	A153005	WASHER, LOCK (3/8")	10	2
9	A153004	WASHER, FLAT (3/8")	10	2
10	A801009	WASHER, IDLER (SQ)	10	1
11	A152004	NUT, HEX (#18-5/16)	10	1
12	A150509	BOLT, MACHINE (5/16-18 X 3")	10	1

*Color Code (-)=Not Shown #=Series, Serial Prefix or Run No., N=Not Available

Section: GAS BURNER

Model: MDG50PNHWQ

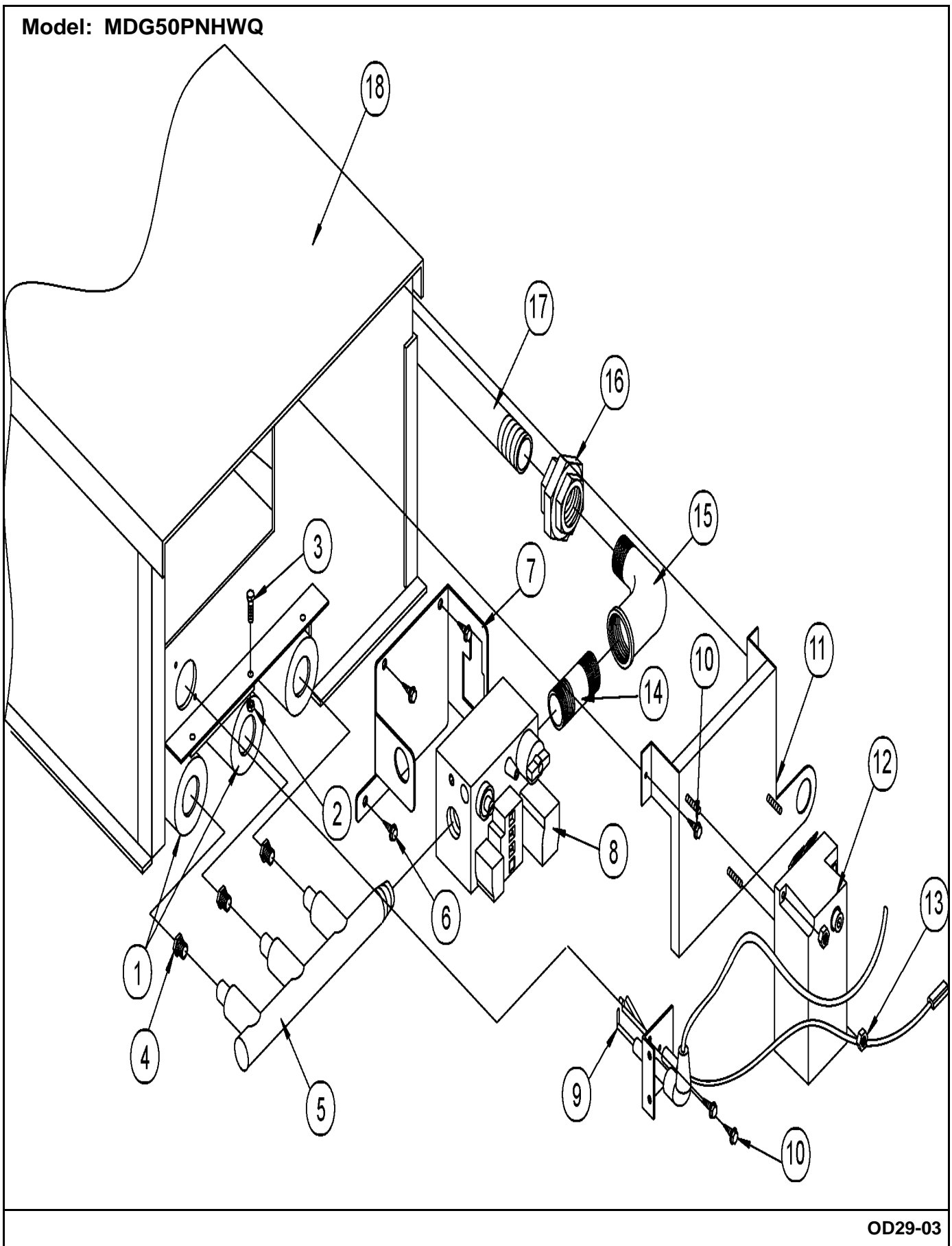

OD29-03

Section: GAS BURNER

No.	Part No.	Description	Series	Qty
-	A000000	ORDER PART FROM AMERICAN DRYER Note: #508-678-9000	10	1
1	A141105	BURNER, TUBE (LARGE)	10	3
2	A151001	NUT, PAL (#8-32)	10	3
3	A150108	SCREW, MACHINE	10	3
4	A140820	ORIFICE, BURNER (NAT)	10	3
4	A140806	BURNER ORIFICE (LP)	10	3
5	A141232	MANIFOLD, DSI (3-PORT 1/2")	10	1
6	A150309	SCREW, CRIMPTITE	10	3
7	A318714	BRACKET, HORIZONTAL GAS VALVE	10	1
8	A128927	VALVE, REDUNDANT (1/2" 24VAC)	10	1
8	A880960	VALVE,GAS 1/2" 24 VAC,(LP)	10	1
9	A880134	IGNITER/FLAME PROBE KIT ASSY.	10	1
-	A882537	WIRE, FLAME PROBE	10	1
10	A150300	SCREW (#10-32 X 1/2" PH ROUND)	10	1
11	A817027	MOUNTING BRACKET, DSI ASSY	10	1
-	A815724	ASSY, BRACKET	25	1
12	A128937	MODULE (DSI)	25	1
12	A128935	MODULE (DSI)	10	9
13	A152013	NUT, HEX (#6-32)	10	2
14	A142707	NIPPLE (1/2" X 1-1/2")	10	1
15	A142506	ELBOW, STREET (1/2" X 1/2")	10	1
16	A142600	UNION (1/2")	10	1
17	A142809	PIPE (1/2" X 29 1/8")	10	1
-	A817062	BURNER BOX COMPLETE (NAT)	10	1
-	A883325	CONVERION KIT (NAT TO LP)	10	1
18	A850899	BURNER BOX ONLY	10	1
-	A817063	BURNER BOX COMPLETE (LP)	10	1

*Color Code (-)=Not Shown #=Series, Serial Prefix or Run No., N=Not Available

Section: SAIL SWITCH/HI LIMIT

Model: MDG50PNHWQ

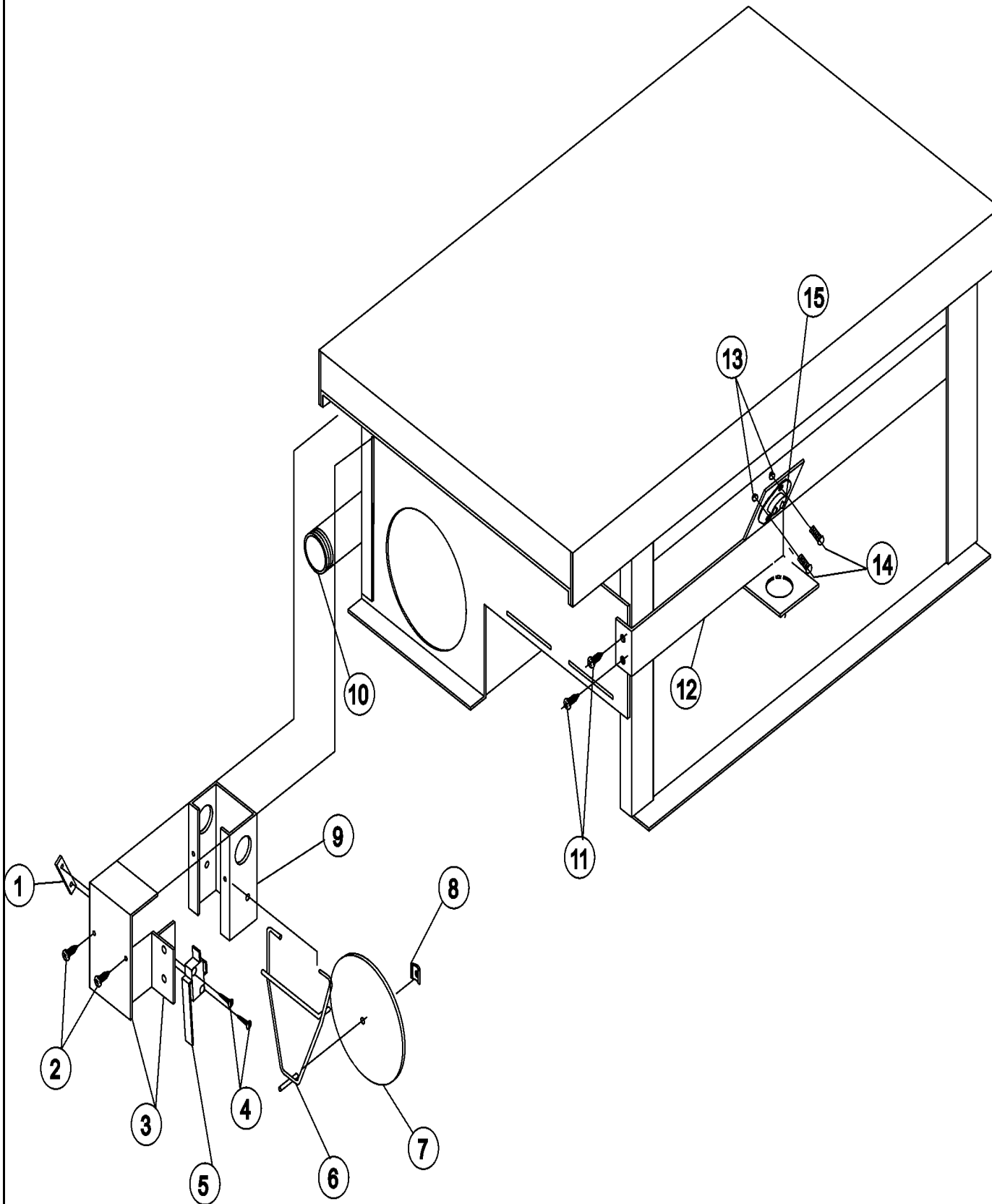

OD31-01

Section: SAIL SWITCH/HI LIMIT

No.	Part No.	Description	Series	Qty
-	A000000	ORDER PART FROM AMERICAN DRYER Note: #508-678-9000	10	1
1	A154004	NUT, TWIN SPEED	10	1
2	A150300	SCREW (#10-32 X 1/2" PH ROUND	10	2
3	A802799	COVER, SAIL SWITCH BOX W/BRKT.	10	1
4	A150303	SCREW (#4 X 3/4")	10	2
5	A122200	SWITCH, SAIL	10	1
6	A105500	ROD, SAIL SWITCH ACTUATOR	10	1
7	A319202	DAMPER, SAIL SWITCH (FLAT)	10	1
8	A154002	FASTENER, PUSH-ON (1/8")	10	1
9	A802800	BOX, SAIL SWITCH (ONLY)	10	1
-	A802801	BOX, SAIL SWITCH ASSY	10	1
10	A142809	PIPE (1/2" X 29 1/8")	10	1
11	A150300	SCREW (#10-32 X 1/2" PH ROUND	10	2
12	A319704	BRACKET, HI-LIMIT MOUNTING	10	1
13	A151000	PAL NUT (#6-32)	10	2
14	A150001	SCREW, MACHINE (#6-32 X 1/2")	10	2
15	A130201	HI-LIMIT	10	1

*Color Code (-)=Not Shown #=Series, Serial Prefix or Run No., N=Not Available

Section: MOTOR MOUNT

Model: MDG50PNHWQ

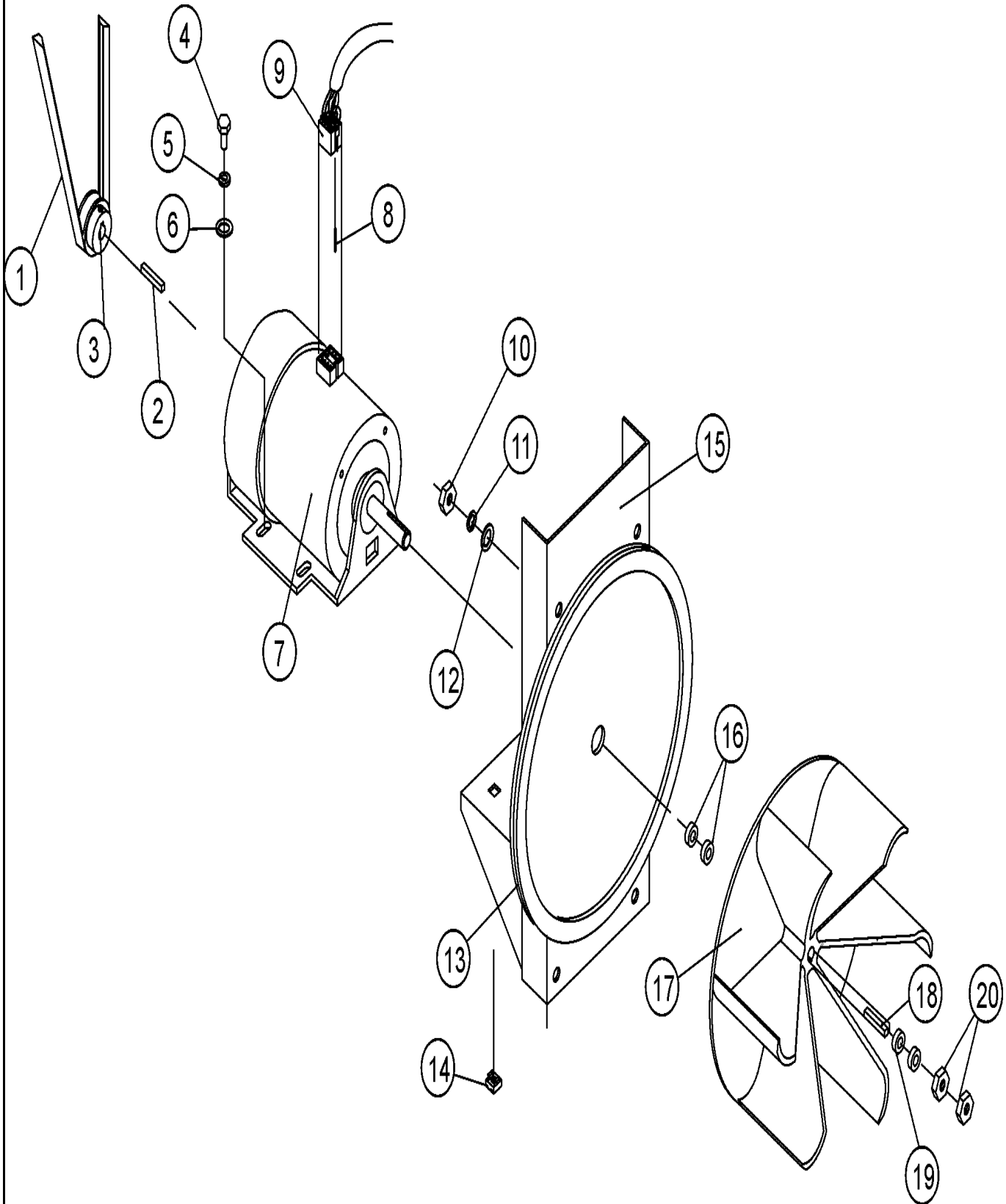

OD17-02

Section: MOTOR MOUNT

No.	Part No.	Description	Series	Qty
-	A000000	ORDER PART FROM AMERICAN DRYER Note: #508-678-9000	10	1
1	A100105	V-BELT	10	1
2	A100701	KEY (3/16" X 3/16")	10	1
3	A101132	PULLEY, MOTOR (5/8" X 2")	10	1
4	A150501	BOLT, MACHINE (#18-5/16 X 3/4)	10	4
5	A153002	WASHER, LOCK (5/16")	10	4
6	A153001	WASHER, FLAT (5/16")	10	4
7	A100069	3/4 HP 115V 10 MOTOR W/PLUG 56	10	1
-	A122801	TOOL, EXTRACTION (PIN/SOCKET)	10	1
8	A122701	TERMINAL, SOCKET (ONLY)	10	8
9	A137030	HOUSING (8 PIN)	10	1
10	A152004	NUT, HEX (#18-5/16)	10	4
11	A153002	WASHER, LOCK (5/16")	10	4
12	A153001	WASHER, FLAT (5/16")	10	4
13	A117604	TAPE, FOAM (SOLD IN FEET)	10	4
14	A154000	NUT (#18-5/16")	10	4
15	A850017	MOTOR, MOUNT	10	1
-	A817029	MOTOR, 3/4HP 60HZ COMPLETE	10	1
16	A153050	WASHER, FLAT (1/2")	10	2
17	A100604	IMPELLOR (12 1/2" W/ 1/2 BORE)	10	1
18	A100702	KEY (1/8" X 1/8" X 1 1/2")	10	1
19	A153050	WASHER, FLAT (1/2")	10	2
20	A152006	NUT, JAM (#20-1/2" LT-HAND)	10	2

*Color Code (-)=Not Shown #=Series, Serial Prefix or Run No., N=Not Available

Section: REAR ELECTRIC PANEL

Model: MDG50PNHWQ

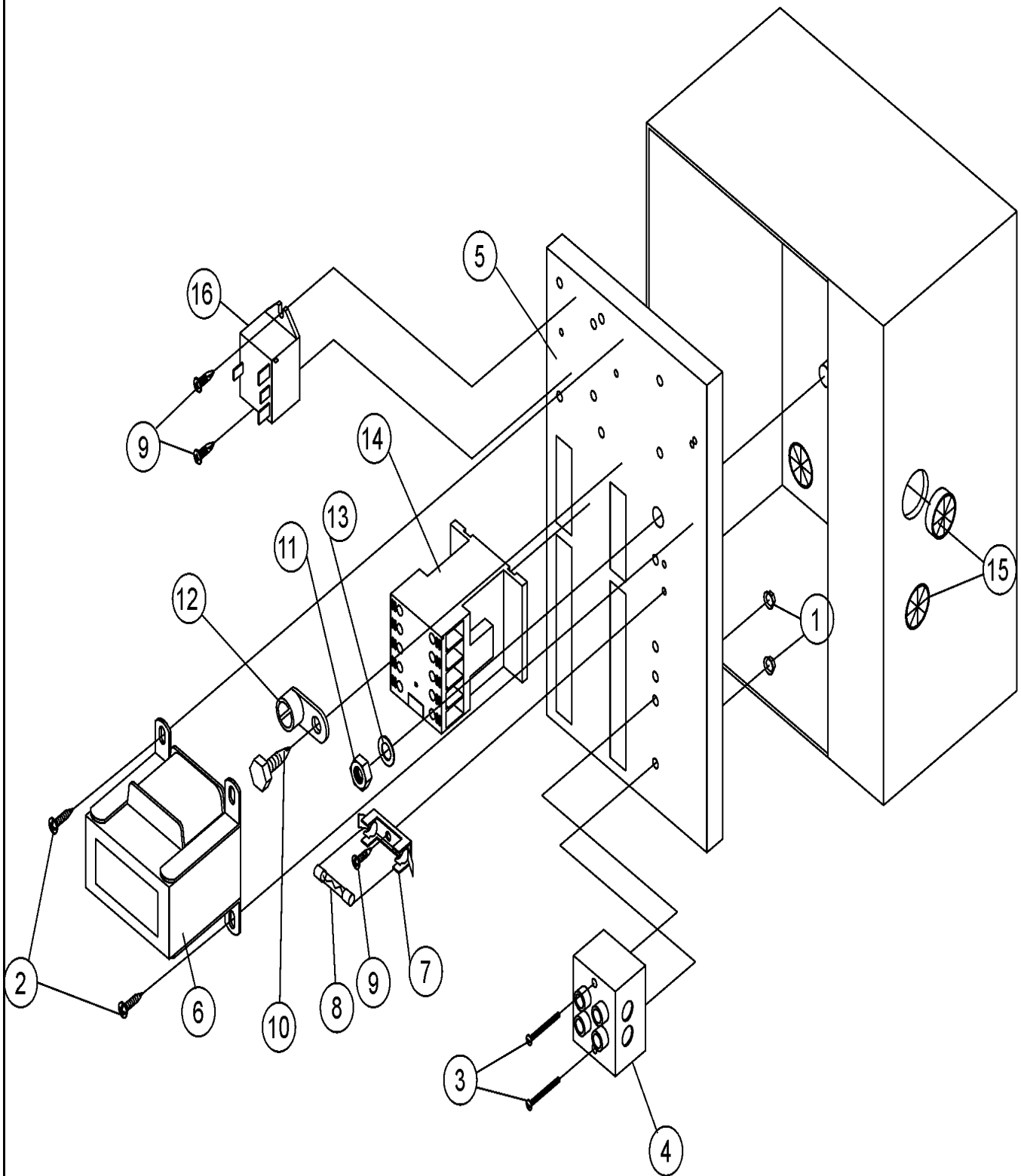

OD21-02

Section: REAR ELECTRIC PANEL

No.	Part No.	Description	Series	Qty
-	A000000	ORDER PART FROM AMERICAN DRYER Note: #508-678-9000	10	1
1	A151000	PAL NUT (#6-32)	10	2
2	A150300	SCREW (#10-32 X 1/2" PH ROUND)	10	2
3	A150008	SCREW, MACHINE	10	2
4	A120716	TERMINAL BLOCK, 2-POSTION	10	1
5	A322812	PLATE, BACK	10	1
-	A822796	PANEL, REAR ELEC. COMPLETE	10	1
6	A830151	TRANSFORMER 115V	10	1
7	A136008	STRIP, FUSE BLOCK (ONLY)	10	1
8	A136057	FUSE, 1/2-AMP SLO-BLO	10	1
9	A150301	SCREW, TEK (#8-18 X 7/16 PH)	10	4
10	A150297	WASHER, TEK SCREW	10	1
11	A152004	NUT, HEX (#18-5/16)	10	1
12	A121010	LUG, GROUND (L-70)	10	1
13	A153002	WASHER, LOCK (5/16")	10	1
14	A132495	CONTACTOR, 3-POLE	10	1
15	A121300	BUSHING, OPEN/CLOSED	10	3
16	A131932	RELAY, SPST 24V	10	1

*Color Code (-)=Not Shown #=Series, Serial Prefix or Run No., N=Not Available

Section: OUTER TOP/BACK GUARD

Model: MDG50PNHWQ

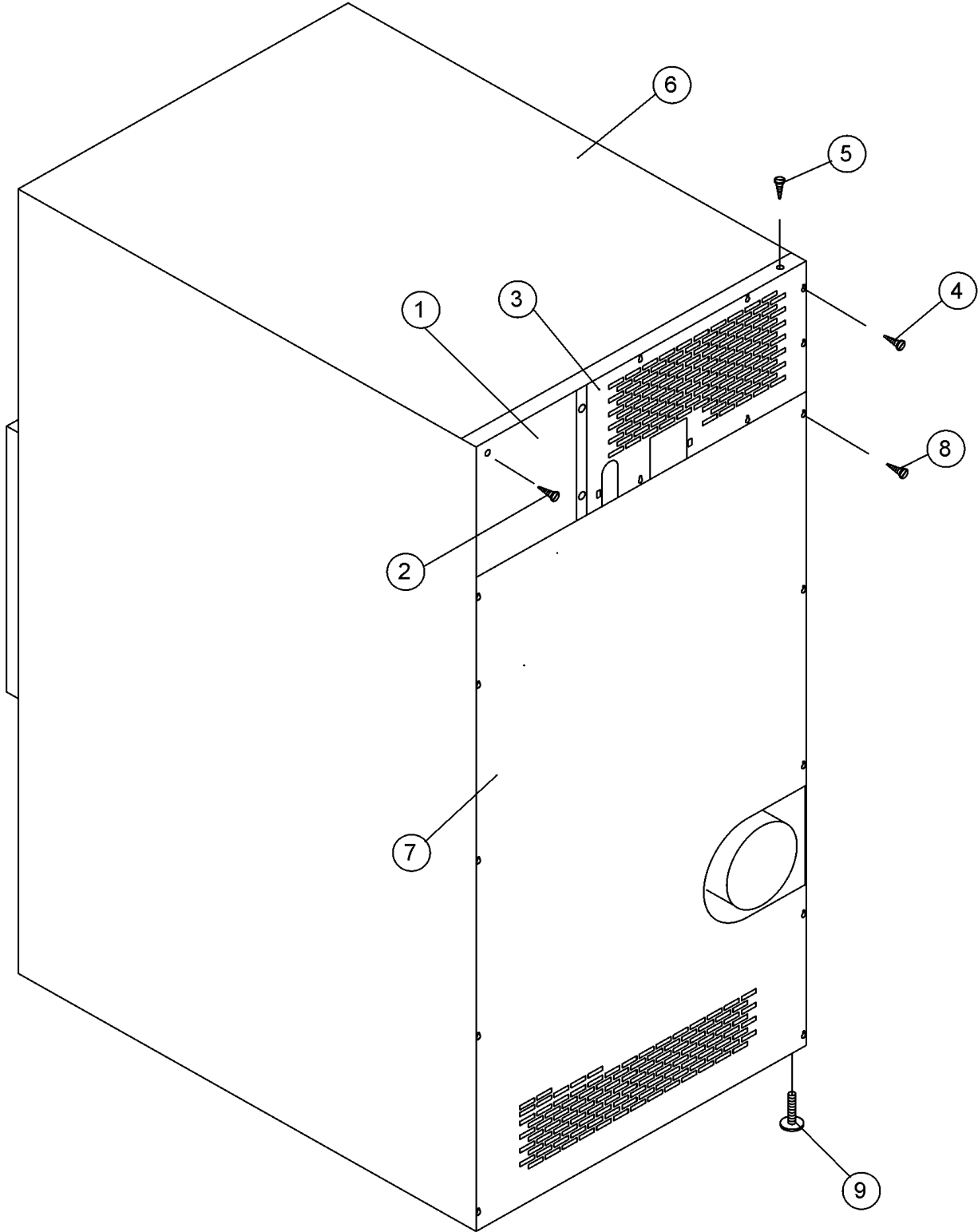

OD18-02

Section: OUTER TOP/BACK GUARD

No.	Part No.	Description	Series	Qty
-	A000000	ORDER PART FROM AMERICAN DRYER Note: #508-678-9000	10	1
1	A322809	COVER, ELECTRICAL BOX (REAR)	10	1
2	A150301	SCREW, TEK (#8-18 X 7/16 PH)	10	4
3	A314424	GUARD, TOP BACK	10	1
4	A150301	SCREW, TEK (#8-18 X 7/16 PH)	10	7
5	A150300	SCREW (#10-32 X 1/2" PH ROUND)	10	10
6	A312533	GUARD, TOP (OUTER)	10	1
7	A322082	GUARD, BOTTOM BACK	10	1
8	A150301	SCREW, TEK (#8-18 X 7/16 PH)	10	13
9	A103500	LEG, LEVELING (ADJUSTABLE)	10	4

*Color Code (-)=Not Shown #=Series, Serial Prefix or Run No., N=Not Available

Section: TEMPERATURE PROBE (SAFE)

Model: MDG50PNHWQ

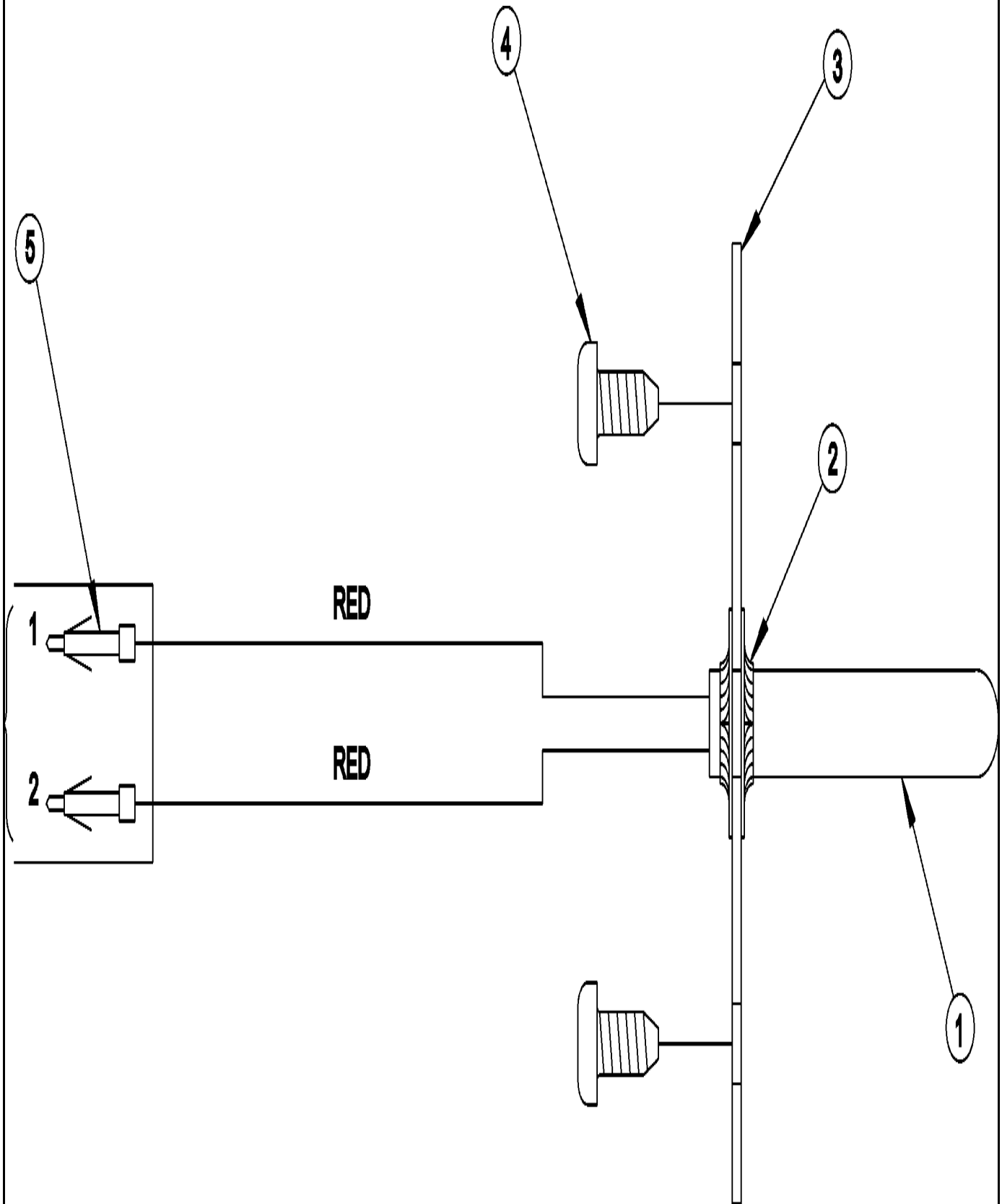

OD21-03

Section: TEMPERATURE PROBE (SAFE)

No.	Part No.	Description	Series	Qty
-	A000000	ORDER PART FROM AMERICAN DRYER Note: #508-678-9000	10	1
1	A822752	PROBE, TEMP (COMPLETE)	10	1
2	A154007	FASTENER, PUSH-ON (1/4")	10	2
3	A390390	BRACKET, SENSOR	10	1
4	A150301	SCREW, TEK (#8-18 X 7/16 PH	10	2
5	A122647	CONNECTOR (NO TERMINALS)	10	1

*Color Code (-)=Not Shown #=Series, Serial Prefix or Run No., N=Not Available

Section: SOLENOID AND PIPING (SAFE)

Model: MDG50PNHWQ

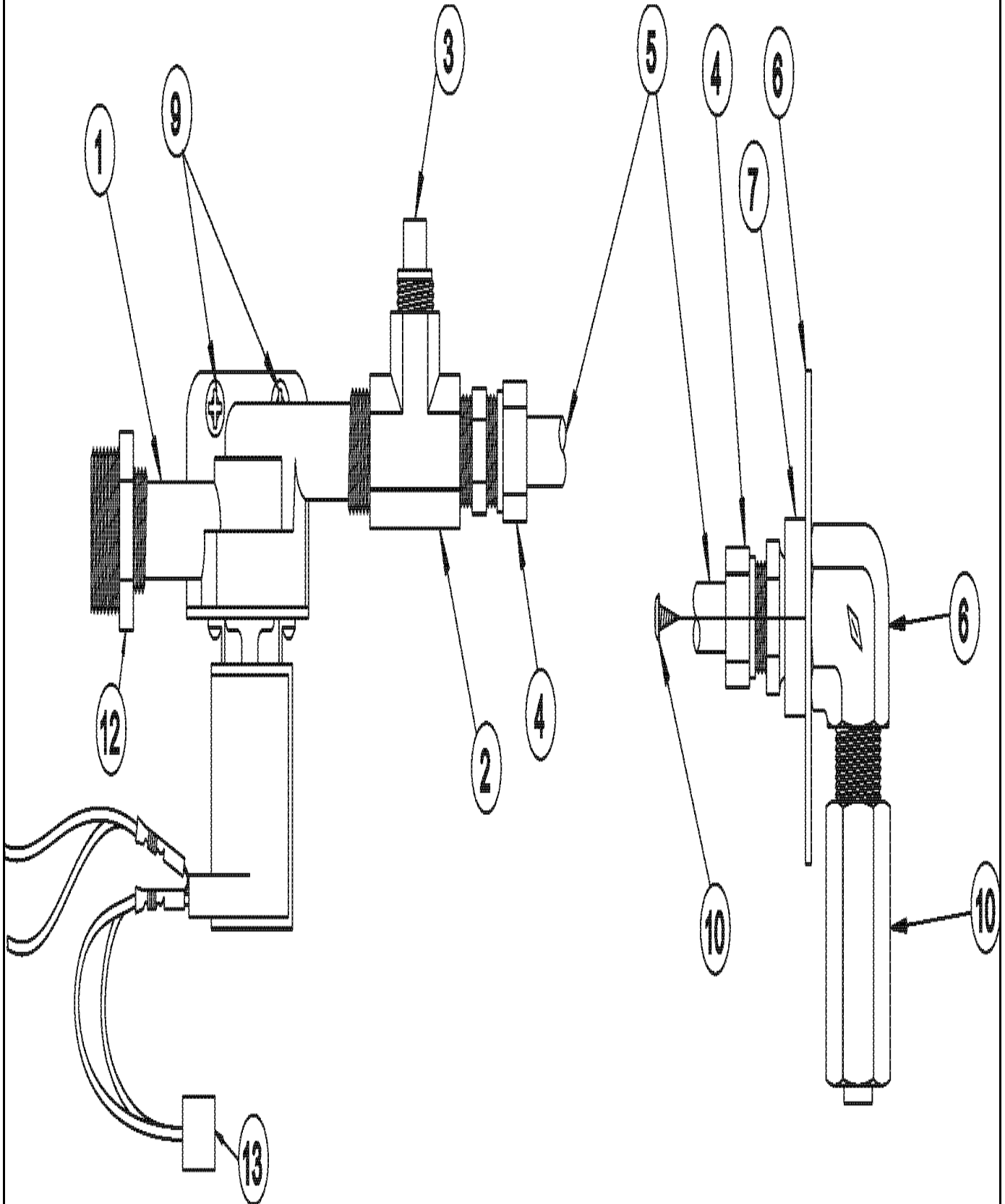

OD21-04

Section: SOLENOID AND PIPING (SAFE)

No.	Part No.	Description	Series	Qty
-	A000000	ORDER PART FROM AMERICAN DRYER Note: #508-678-9000	10	1
1	A165114	VALVE, SOLENOID (SAFE)	10	1
2	A143220	TEE, BRASS 3/8	10	1
3	A143251	PLUG, BRASS 3/8	10	1
4	A143208	CONNECTOR, BRASS 3/8	10	2
5	A143099	TUBING, WALL COPPER (FOOT)	10	6
6	A311588	MOUNTING PLATE, SPRINKLER	10	6
7	A143303	LOCKNUT, BRASS	10	1
8	A143155	ELBOW, BRASS 90 DEG	10	1
9	A150430	SCREW, SELF DRILLING (PH)	10	2
10	A150301	SCREW, TEK (#8-18 X 7/16 PH)	10	2
11	A143581	NOZZLE, SPRAY	10	1
12	A142888	BUSSING, 1/2 X 3/8	10	1
13	A824081	NETWORK, R.C.	10	1

*Color Code (-)=Not Shown #=Series, Serial Prefix or Run No., N=Not Available

Section: SUPPLEMENTAL INFORMATION

No.	Part No.	Description	Series	Qty
-	A000000	ORDER PART FROM AMERICAN DRYER Note: #508-678-9000	10	1
1	A120800	CONNECTOR, IN-LINE (1/4")	10	1
2	A120903	NUT, WIRE (CRIMP-ON)	10	1
3	A120802	CONNECTOR, RED BUTT	10	1
4	A120902	NUT, WIRE (#74B)	10	1
5	A121500	TIE, HARNESS (7")	10	1

*Color Code (-)=Not Shown #=Series, Serial Prefix or Run No., N=Not Available

Section: LINT DRAWER/SWITCH SERIES 11

Model: MDG50PNHWQ

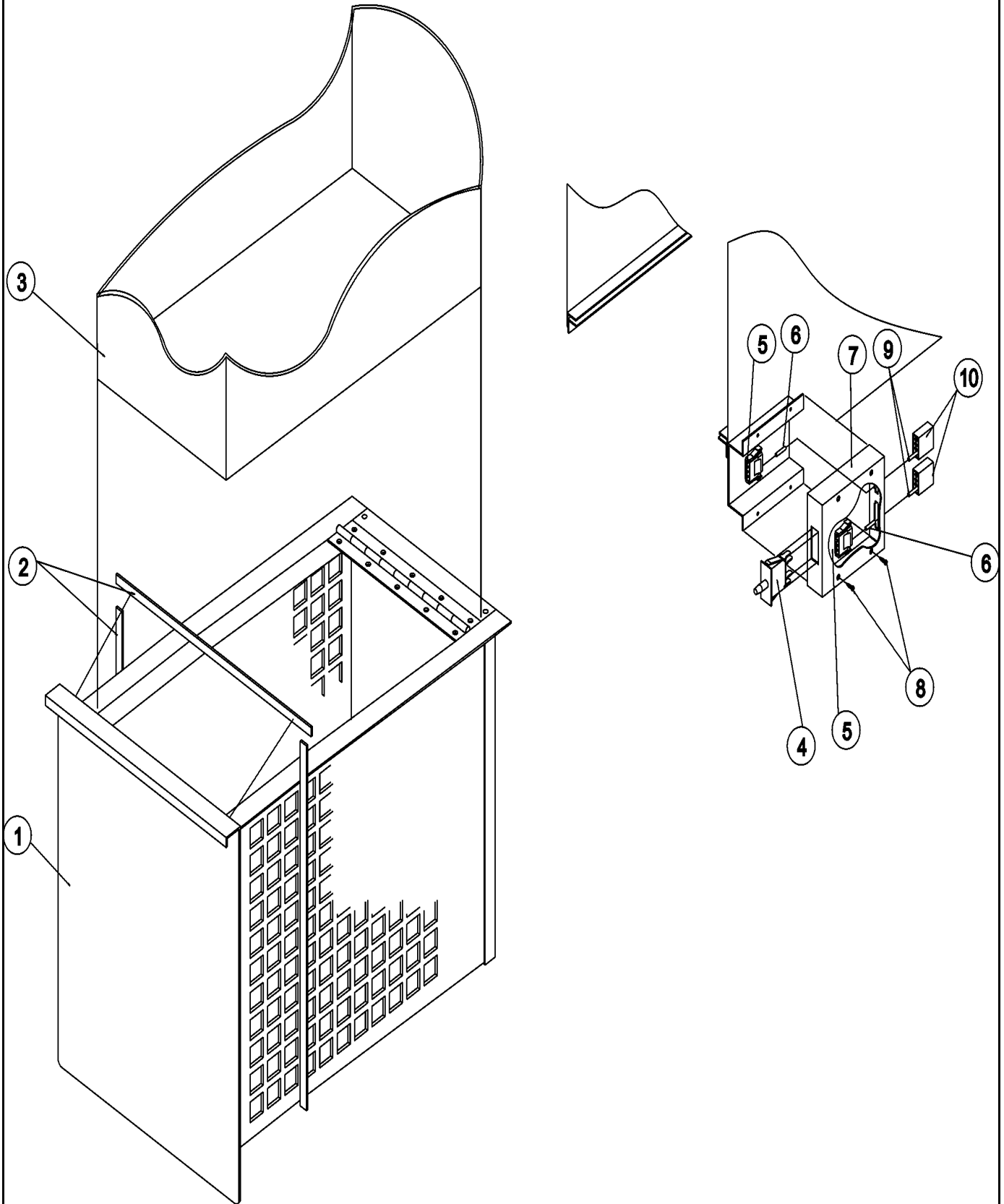

OD16-08

Section: LINT DRAWER/SWITCH SERIES 11

No.	Part No.	Description	Series	Qty
-	A000000	ORDER PART FROM AMERICAN DRYER Note: PHONE #508-678-9000	11	1
1	A850962	ASSY, LINT DRAWER Note: INCLUDES 1 THRU 3, SPECIFY COLOR	11	1
1	A850963	ASSY, LINT DRAWER (SS) Note: INCLUDES 1 THRU 3	11	1
2	A117604	TAPE, FOAM (SOLD IN FEET)	11	4
3	A108225	ASSY, LINT SCREEN	11	1
4	A122116	SWITCH, LINT BASKET	11	1
5	A122605	CONNECTOR, 4-PIN SOCKET	11	2
6	A122701	TERMINAL, SOCKET (ONLY)	11	4
-	A122801	TOOL, EXTRACTION (PIN/SOCKET)	11	1
-	A800478	SWITCH BOX, LINT DRAWER ASSY	11	1
7	A304136	SWITCH BOX, COVER ONLY	11	1
8	A150301	SCREW, TEK (#8-18 X 7/16 PH	11	2
9	A122700	TERMINAL, PIN	11	4
10	A122604	CONNECTOR (4 PIN)	11	2

*Color Code (-)=Not Shown #=Series, Serial Prefix or Run No., N=Not Available

