



ML-170 Parts Manual
Phase 6 Microprocessor Models
Dual Timer Models
1996 thru 2000

American Dryer Corporation
88 Currant Road
Fall River, MA 02720-4781
Telephone: (508) 678-9000 / Fax: (508) 678-9447
e-mail: techsupport@amdry.com

Retain This Manual In A Safe Place For Future Reference

American Dryer Corporation products embody advanced concepts in engineering, design, and safety. If this product is properly maintained, it will provide many years of safe, efficient, and trouble-free operation.

ONLY qualified technicians should service this equipment.

OBSERVE ALL SAFETY PRECAUTIONS displayed on the equipment or specified in the installation/operator's manual included with the dryer.

The following “**FOR YOUR SAFETY**” caution **must be** posted near the dryer in a prominent location.

FOR YOUR SAFETY

Do not store or use gasoline or other flammable vapors or liquids in the vicinity of this or any other appliance.

POUR VOTRE SÉCURITÉ

Ne pas entreposer ni utiliser d'essence ni d'autres vapeurs ou liquides inflammables dans le voisinage de cet appareil ou de tout autre appareil.

We have tried to make this manual as complete as possible and hope you will find it useful. **ADC** reserves the right to make changes from time to time, without notice or obligation, in prices, specifications, colors, and material, and to change or discontinue models.

Important

For your convenience, log the following information:

DATE OF PURCHASE _____ **MODEL NO.** **ML-170** _____

DISTRIBUTORS NAME _____

Serial Number(s) _____

Replacement parts can be obtained from your distributor or the **ADC** factory. When ordering replacement parts from the factory, you can FAX your order to **ADC** at (508) 678-9447 or telephone your orders directly to the **ADC** Parts Department at (508) 678-9000. Please specify the dryer **model number** and **serial number** in addition to the **description** and **part number**, so that your order is processed accurately and promptly.

The illustrations on the following pages may not depict your particular dryer exactly. The illustrations are a composite of the various dryer models. Be sure to check the descriptions of the parts thoroughly before ordering.

“IMPORTANT NOTE TO PURCHASER”

Information must be obtained from your local gas supplier on the instructions to be followed if the user smells gas. These instructions must be posted in a prominent location near the dryer.

Table of Contents

Control Door Assembly	3
Microprocessor Control Panel Assembly	4
Dual Timer Control Panel Assembly	5
Front Panel/Main Door Assemblies for models mfd. as of October 22, 1997	6, 7
Front Panel/Main Door Assemblies for models mfd. prior to October 22, 1997	8, 9
Main Door Switch Assembly for models mfd. as of October 22, 1997	10
Main Door Switch Assembly for models mfd. prior to October 22, 1997	11
Basket (Tumbler)/Support Assemblies	12
Lint Door Assembly	13
Lint Drawer/Lint Drawer Switch Box Assemblies for models mfd. as of September 1999	14
Lint Drawer/Lint Drawer Switch Box Assemblies for models mfd. prior to September 1999	15
Tumbler Bearing Mount Assembly	16, 17
Idler Bearing Mount Assembly	18, 19
Totally Enclosed, Fan-Cooled (T.E.F.C.) Basket/Tumbler Motor Mount Assembly	20, 21
Fan (Impellor/Blower) Shaft Assembly	22, 23
Blower Motor Mount Assembly	24, 25
Microprocessor Temperature Sensor Bracket Assembly	26
Dual Timer Temperature Sensor Bracket Assembly	27

Hot Surface Ignition (HSI) Burner Assembly for Gas Models ONLY	28, 29
Sail Switch Assembly	30
Air Jet Assembly	31
Steam Damper Assembly for Steam Models ONLY	32, 33
Microprocessor Reversing Contactor Mounting Panel Assembly	34, 35
Dual Timer Reversing Relay Mounting Panel Assembly	36, 37
Pneumatic (Air) Valve Assembly for Gas Models ONLY	38
Pneumatic (Air) Valve Assembly for Steam Models ONLY	39
Top Console Assembly	40, 41
Back Guard Assemblies	42, 43
Step Down Transformer Usage Listing	44
Additional Parts Available	45

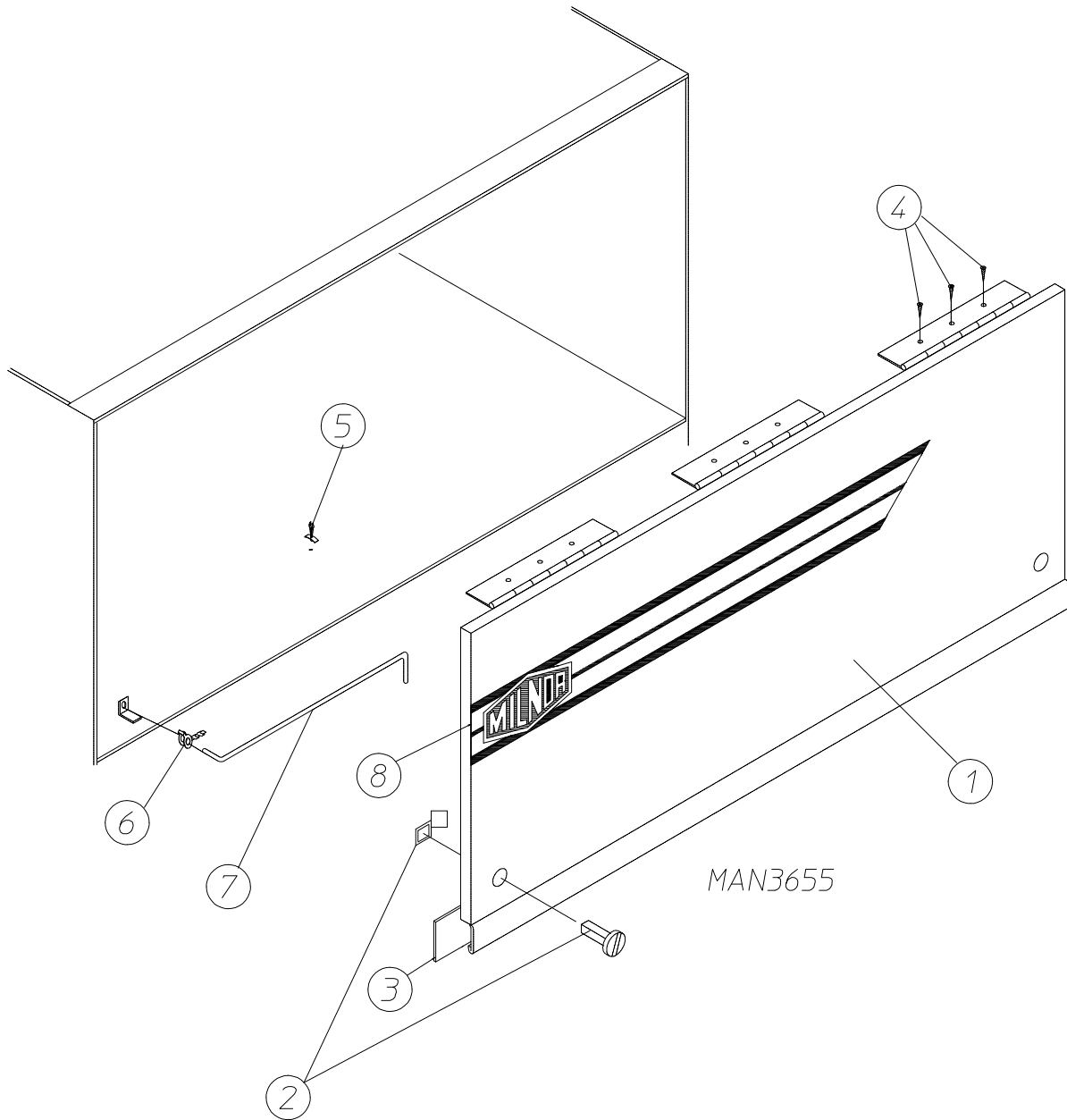

<u>Illus. No.</u>	<u>Part No.</u>	<u>Qty.</u>	<u>Description</u>
1	882495	1	White Control Door Assembly (includes illus. nos. 1 and 2)
	882496	1	Wrinkle Coral Blue Control Door Assembly (includes illus. nos. 1 and 2)
	881602	1	Control Door ONLY
2	160005	2	Spring Turn Latch (2-piece)
3	117603	5	Gasket (sold by the foot)
4	150309	9	#10-16 x 1/2" Hex Head TEK Crimptite Screw
5	102600	1	Control Door Support Rod Catch
6	102601	1	Control Door Rod Retainer Clip
7	102505	1	Control Door Support Rod
8	112368	1	Logo ONLY

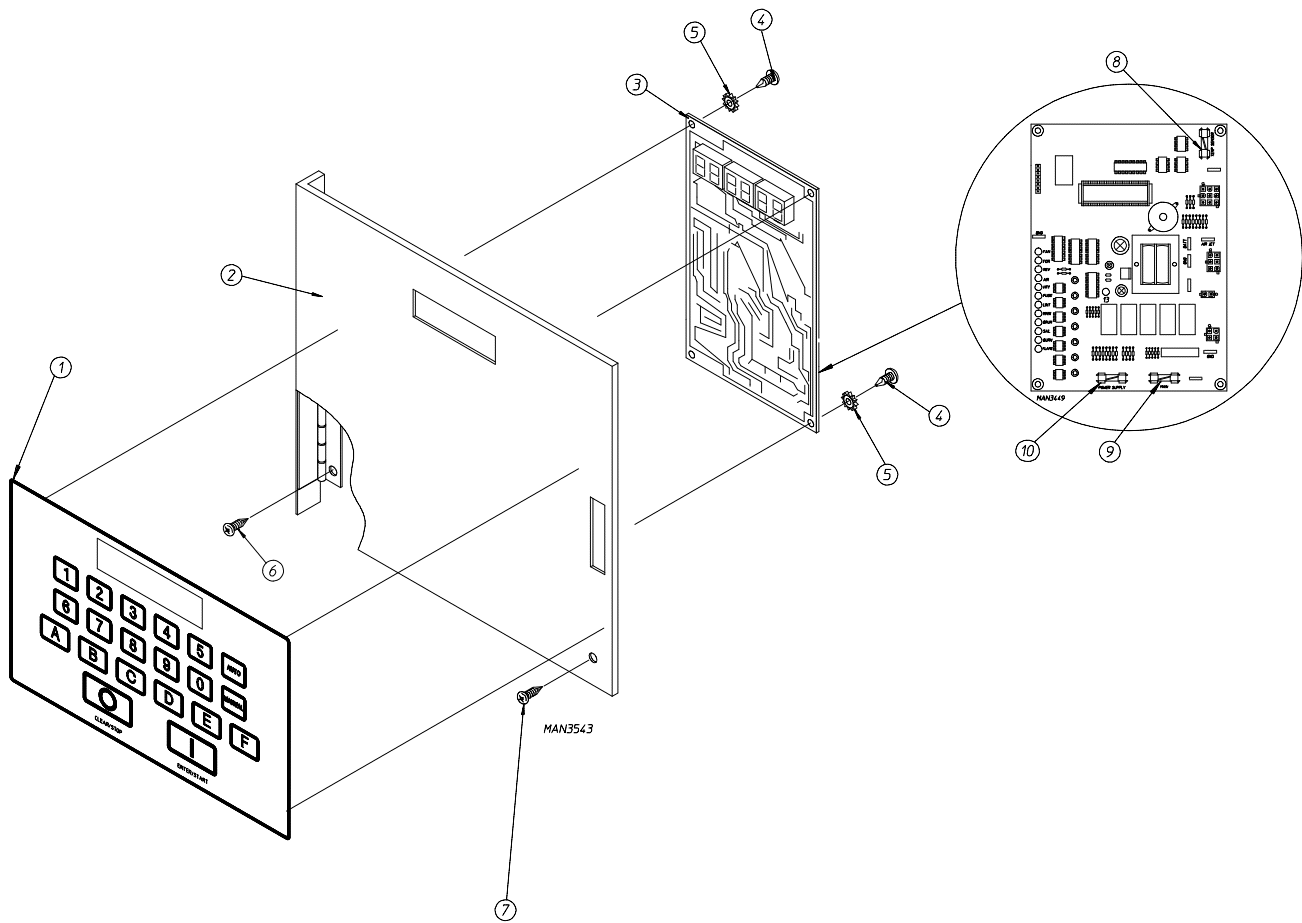

<u>Illus. No.</u>	<u>Part No.</u>	<u>Qty.</u>	<u>Description</u>
1	112537	1	Phase 6 OPL Keypad
	112276	1	OPL Stick-on Labels (English ONLY) ... Not Illustrated
	112275	1	OPL Stick-on Labels (Spanish, Italian, and Hebrew) ... Not Illustrated
	112277	1	3-Language OPL Stick-on Labels (English, Spanish, and Hebrew) ... Not Illustrated
	112278	1	5-Language OPL Stick-on Labels (Italian, Dutch, French, German, and Chinese) ... Not Illustrated
2*	881635	1	Computer Door Complete (includes illus. nos. 1 through 10)
	881633	1	Computer Door ONLY
3	137124	1	Phase 6 OPL Reversing Microprocessor Controller (with Air Jet) ONLY
4	150005	2	6-32 x 1/4" Phillips Round Head Screw
5	153010	2	#6 Star Washer
6	150000	3	6-32 x 1/4" Slotted Round Head Machine Screw
7	150000	1	6-32 x 1/4" Slotted Round Head Machine Screw
8	136048	1	1/8-Amp (Slo-Blo) Fuse ONLY
9	136017	1	3.15-Amp Fuse
10	136019	1	1-Amp Fuse

* Specify color when ordering.

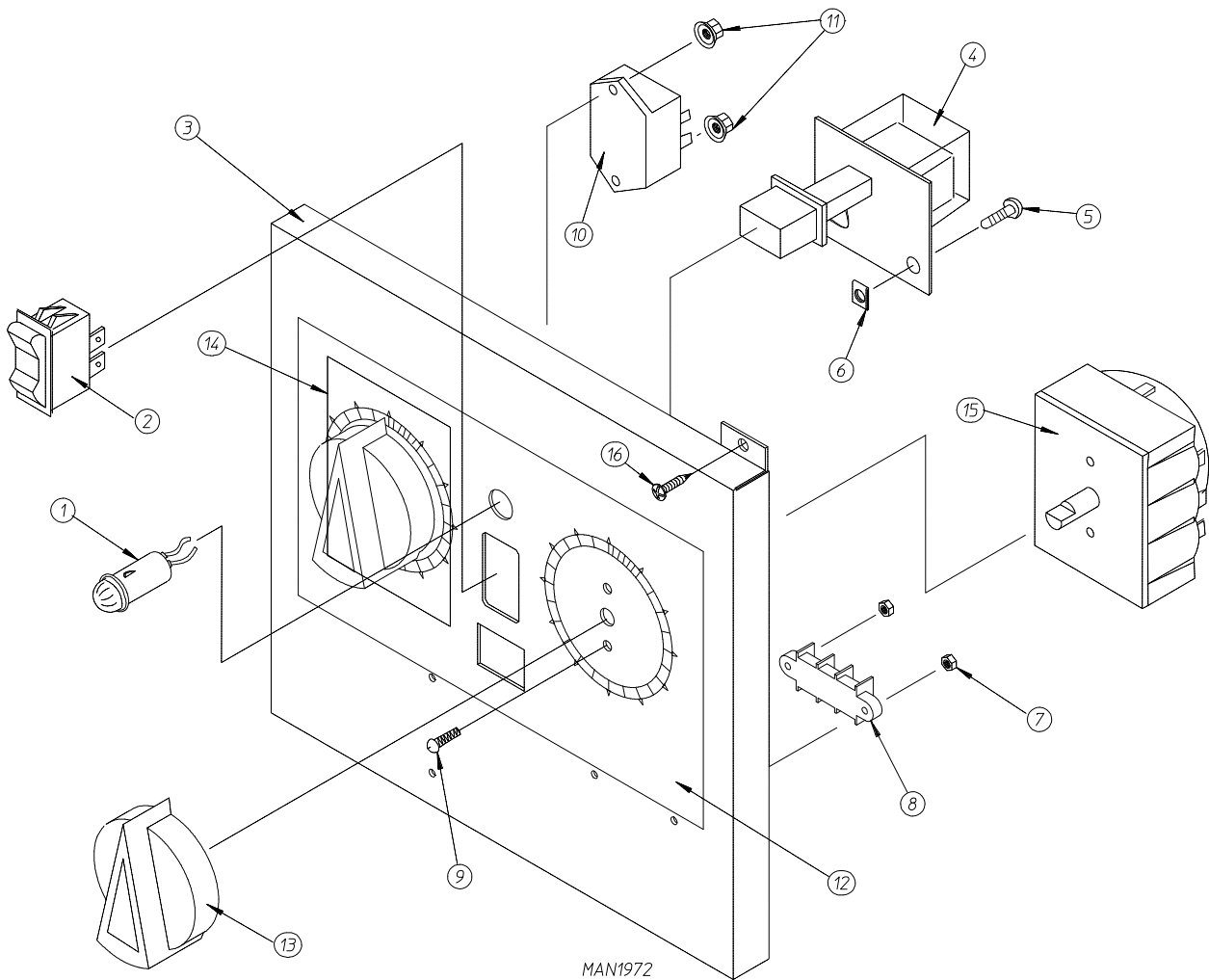

<u>Illus. No.</u>	<u>Part No.</u>	<u>Qty.</u>	<u>Description</u>
1	123005	1	Red Light Indicator - 24 VAC
2	122400	1	Rocker Heat Selector Switch
3*	881056	1	Dual Timer Control Panel Assembly Complete (includes illus. nos. 1 through 15)
	821118	1	Dual Timer Control Panel
4	131917	1	Push-to-Start Relay - 24 VAC
5	150207	2	#10-24 x 1/2" Round Head Machine Screw
6	154001	2	#10-24 Speed Nut
7	152000	2	#6-32 Hex Nut
8	120708	1	Terminal Strip
9	150110	2	#8-32 x 1/4" Phillips Round Head Screw
10	131931	1	Dual Timer Relay - 24 VAC
11	151000	2	#6-32 Pal Nut
12	112050	1	Dual Timer Label ONLY
13	124103	2	Arrow Timer Knob
14	124025	1	60-Minute Timer - 24 VAC
15	124030	1	15-Minute Timer - 24 VAC
16	150301	1	#8-18 x 7/16" Phillips Pan Head TEK Screw

* Specify color when ordering.

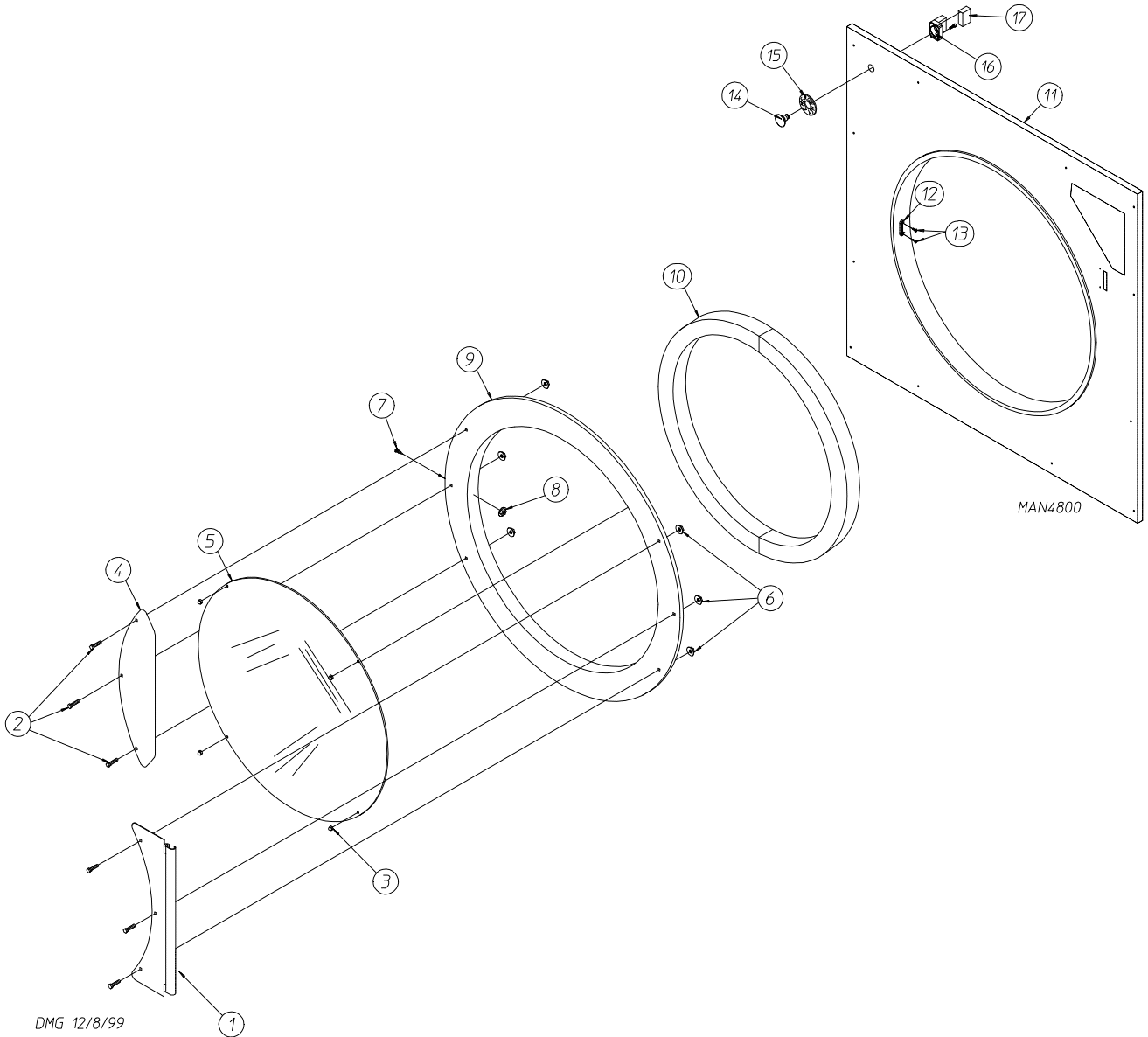

 for models mfd. as of October 22, 1997

<u>Illus. No.</u>	<u>Part No.</u>	<u>Qty.</u>	<u>Description</u>
1	881685	1	White Main Door Hinge
	882296	1	Coral Wrinkle Blue Main Door Hinge
2	881740	6	White 1/4-20 x 5/8" Carriage Bolt
	881739	6	Coral Wrinkle Blue 1/4-20 x 5/8" Carriage Bolt
3	151012	1	#10-32 Acorn Nut (White)
4	881688	1	White Main Door Handle
	881737	1	Blue Main Door Handle
5	102214	1	30" Door Glass
	170730	1	Door Glass Adhesive (10.3 oz. cartridge)
6	881806	6	1/4-20 Free Spin Wash Nut (White)
	882293	6	1/4-20 Free Spin Wash Nut (Coral Wrinkle Blue)
7	150120	1	Main Door Latch Screw (#10-32 Dome Hex Head Screw)
8	151010	1	#10-32 Acorn Nut
9	881689	1	White Main Door Assembly Complete (includes illus. nos. 2 through 10)
	881761	1	Coral Wrinkle Blue Main Door Assembly Complete (includes illus. nos. 2 through 10)
	881966	1	White Main Door Ring
	882305	1	Coral Wrinkle Blue CRS Large Main Door Ring
10	882411	1	Extruded Steel Door Gasket
11	882503	1	White Front Panel Assembly (includes illus. nos. 1, 15, and 16)
	882504	1	Coral Wrinkle Blue Front Panel Assembly (includes illus. nos. 1, 15, and 16)
12	170330	1	Friction Door Latch
13	154215	2	5/32" Pop Rivet
14	122351	1	"EMERGENCY STOP" (E-Stop) Push-Pull Button
15	122419	1	"EMERGENCY STOP" (E-Stop) Nameplate
16	132387	1	Normally Closed (N.C.) Contact Block
17	132395	1	Normally Closed (N.C.) Contact Block with Base

for models mfd. prior to October 22, 1997

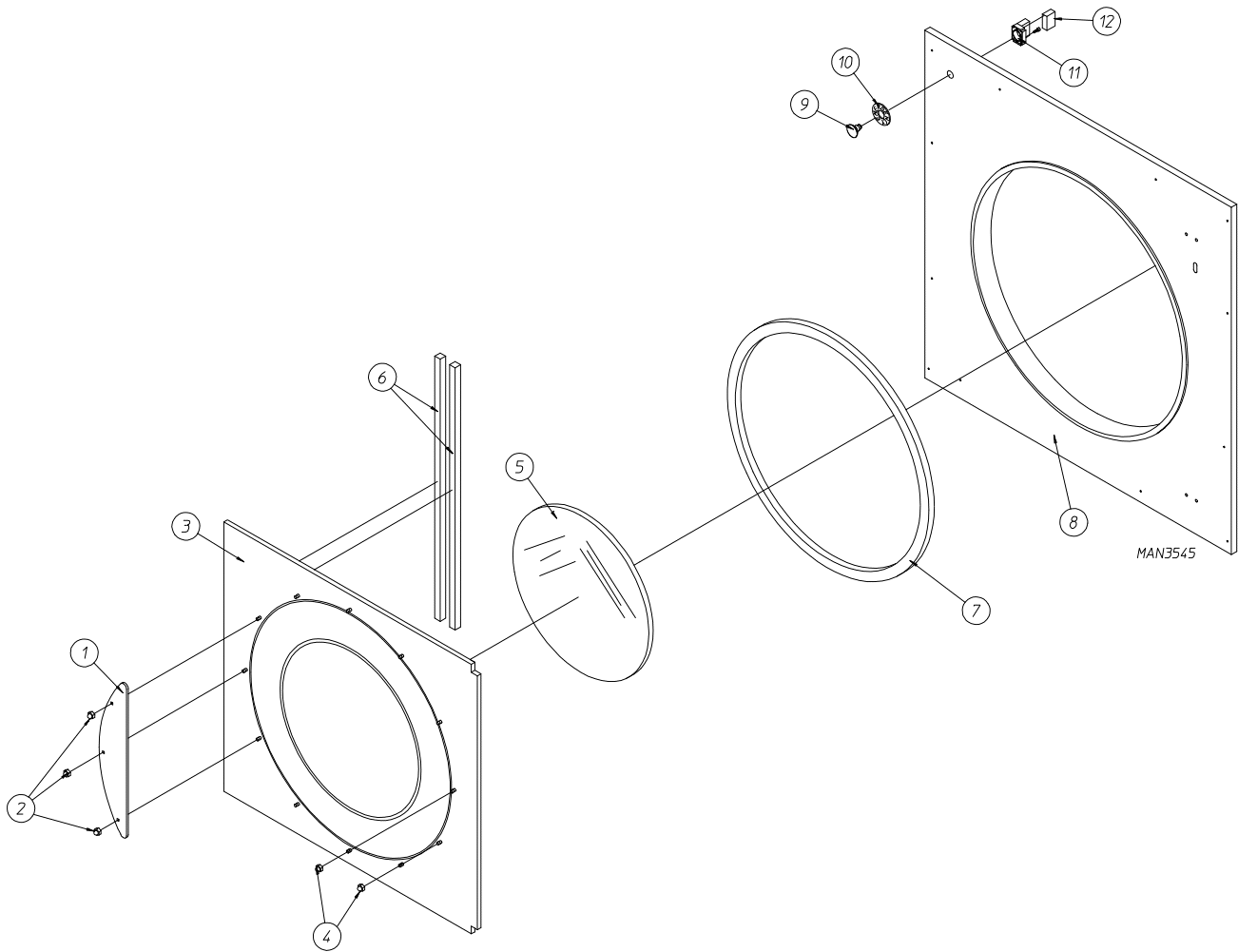

for models mfd. prior to October 22, 1997

<u>Illus. No.</u>	<u>Part No.</u>	<u>Qty.</u>	<u>Description</u>
1	881741	1	White Main Door Handle
	881760	1	Blue Main Door Handle
2	151011	3	5/16-18 (Nickel Plated) Acorn Nut
3	881816	1	White Main Door Assembly Complete (includes illus. nos. 1 through 7)
	881820	1	Blue Main Door Assembly Complete (includes illus. nos. 1 through 7)
	881552	1	White Main Door ONLY
	881550	1	Blue Main Door ONLY
4	151011	9	5/16-18 (Nickel Plated) Acorn Nut
5	102210	1	20-7/16" Door Glass
	170730	1	Door Glass Adhesive (10.3 oz. cartridge)
6	102112	2	Door Magnet (5/16" x 1/4" x 34-3/4")
7	102356	1	Main Door Gasket (13-1/6" x 1-3/8" x 97-1/2")
8*	881551	1	Front Panel Assembly
9	122351	1	"EMERGENCY STOP" Push-Pull Button
10	122419	1	"EMERGENCY STOP" Nameplate
11	132395	1	Normally Closed (N.C.) Contact Block with Base
12	132387	1	Normally Closed (N.C.) Contact Block

* Specify color when ordering.

for models mfd. as of October 22, 1997

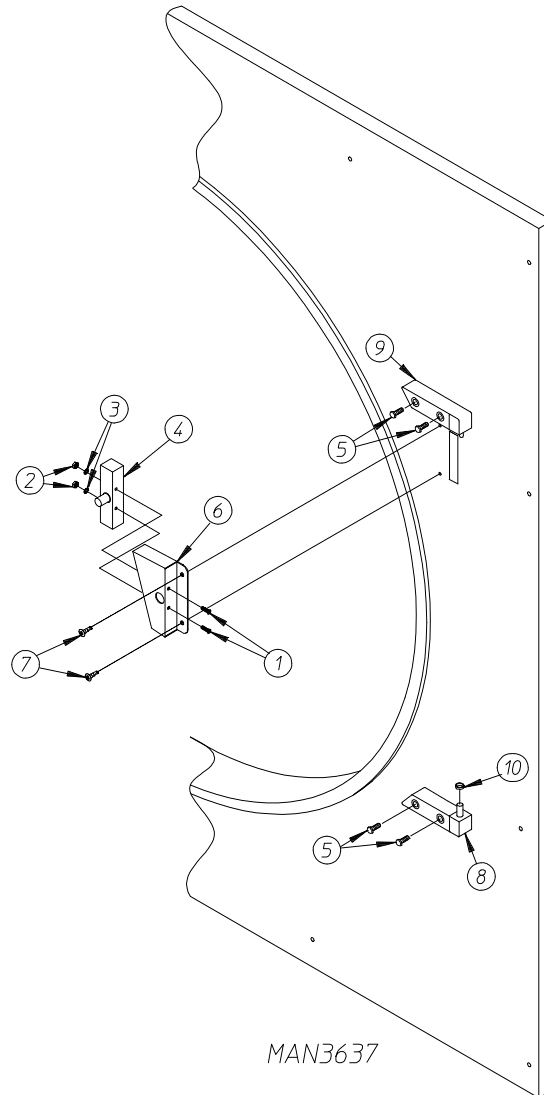

<u>Illus. No.</u>	<u>Part No.</u>	<u>Qty.</u>	<u>Description</u>
1	150006	2	#6-32 x 7/8" Phillips Pan Head Machine Screw
2	152013	2	#6-32 Hex Nut
3	153010	2	#6 Star Washer
4	137005	1	Single Pole Door Switch
5	150443	4	1/4-20 x 3/4" Stainless Steel Cap Screw
6	881687	1	White Main Door Switch Housing ONLY
	881695	1	Blue Main Door Switch Housing ONLY
	881702	1	White Main Door Switch with Housing Assembly (includes illus. nos. 1 through 4 and 6)
	881700	1	Blue Main Door Switch with Housing Assembly (includes illus. nos. 1 through 4 and 6)
7	150443	2	1/4-20 x 3/4" Stainless Steel Cap Screw
8	881441	1	White Bottom Hinge Block
	881735	1	Blue Bottom Hinge Block
9	881440	1	White Top Hinge Block
	881736	1	Blue Top Hinge Block
10	153031	1	Nylon Washer

for models mfd. prior to October 22, 1997

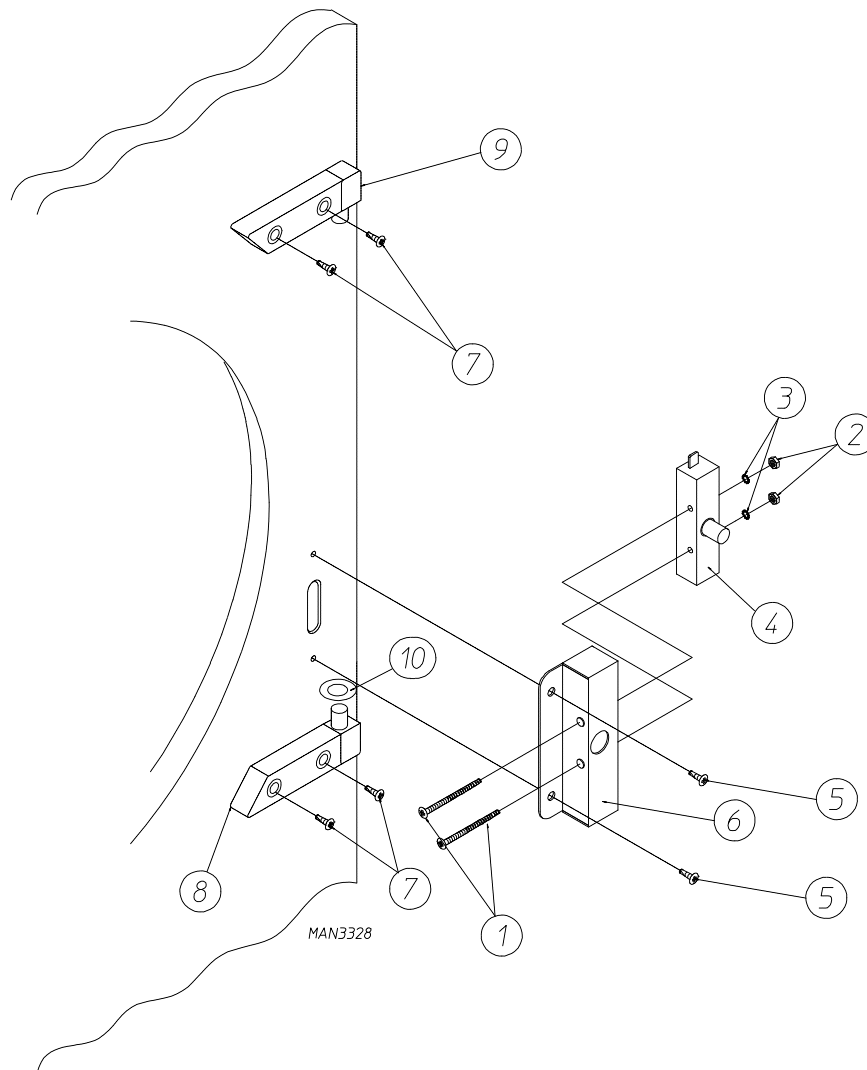

<u>Illus. No.</u>	<u>Part No.</u>	<u>Qty.</u>	<u>Description</u>
1	150006	2	#6-32 x 7/8" Phillips Pan Head Machine Screw
2	152013	2	#6-32 Hex Nut
3	153010	2	#6 Star Washer
4	137005	1	Single Pole Door Switch
5	150301	2	#8 x 7/16" Phillips Head TEK Screw
6	881698	1	White Main Door Switch with Housing Assembly (includes illus. nos. 1 through 4 and 6)
	881699	1	Blue Main Door Switch with Housing Assembly (includes illus. nos. 1 through 4 and 6)
	881726	1	White Main Door Switch Housing ONLY
	881727	1	Blue Main Door Switch Housing ONLY
7	150443	4	Socket Cap Screw
8	881441	1	White Bottom Hinge Block
	881735	1	Blue Bottom Hinge Block
9	881440	1	White Top Hinge Block
	881736	1	Blue Top Hinge Block
10	153031	1	Nylon Washer

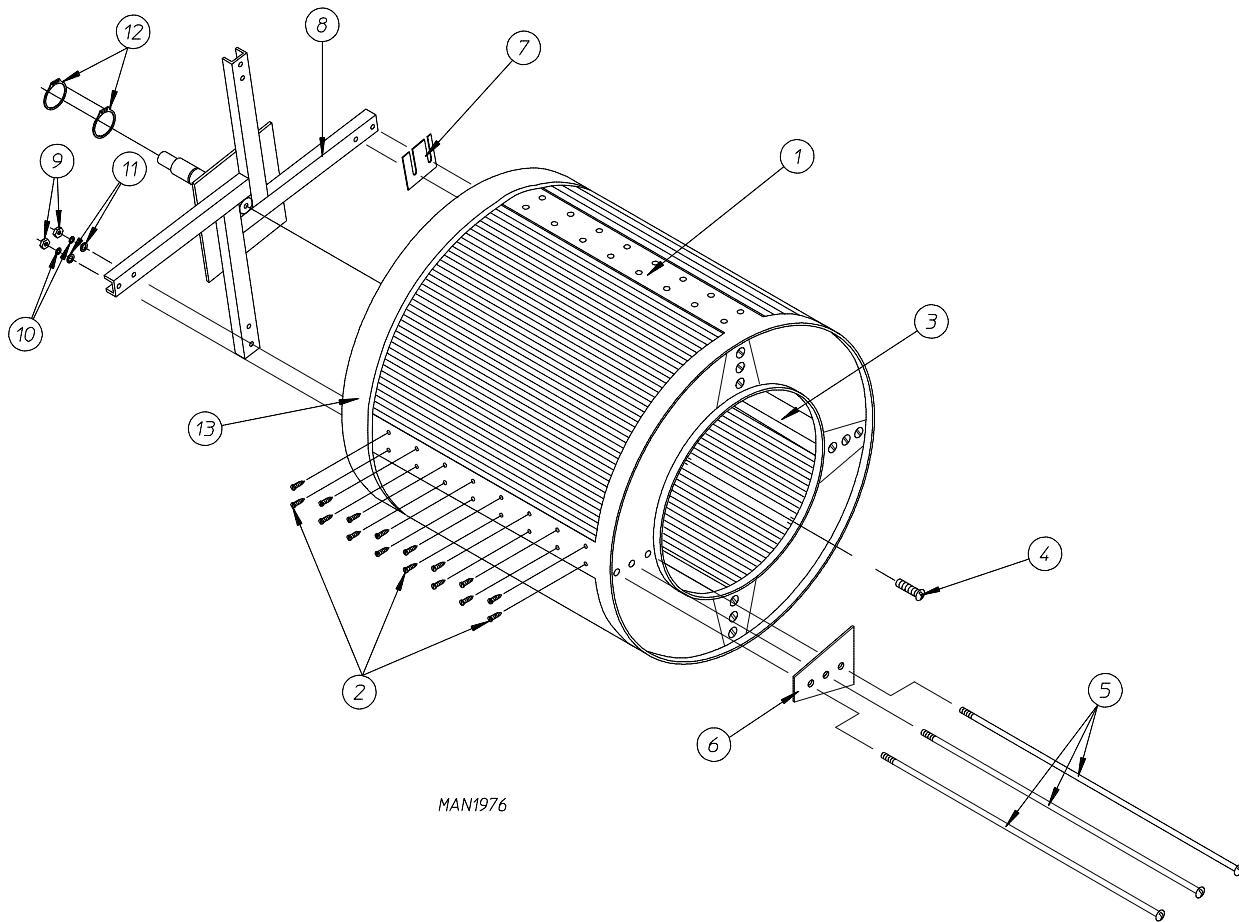

<u>Illus. No.</u>	<u>Part No.</u>	<u>Qty.</u>	<u>Description</u>
1	820979*	1	Basket (Tumbler) ONLY without Felt Collar
	821795	1	Basket (Tumbler) and Support Assembly Complete (includes illus. nos. 1 through 13) For models mfd. as of August 27, 1997
	821001	1	Basket (Tumbler) and Support Assembly Complete (includes illus. nos. 1 through 13) For models mfd. prior to August 27, 1997
2	150309	64	#10-16 x 1/2" Hex Head TEK Crimptite Screw
3	332140	4	Basket (Tumbler) Rib ONLY
4	150500	1	5/16-18 x 3/4" Socket Button Head Screw
5	100910	12	1/2-13 x 44" Tie Rod
6	332139	4	Basket (Tumbler) Reinforcing Plate ONLY
7	332177	**	Basket (Tumbler) Shim ONLY
8	821191	1	Basket (Tumbler) Support ONLY (for models mfd. as of August 27, 1997)
	821000	1	Basket (Tumbler) Support ONLY (for models mfd. prior to August 27, 1997)
9	152009	12	7/16-14 Hex Nut
10	153013	12	7/16" Lock Washer
11	153011	12	9/16" Flat Washer
12	100810	2	3-1/8" Retaining Ring
13	116007	1	Felt Collar ONLY

* Felt collar *is not included* and **must be** ordered separately.

** As required.

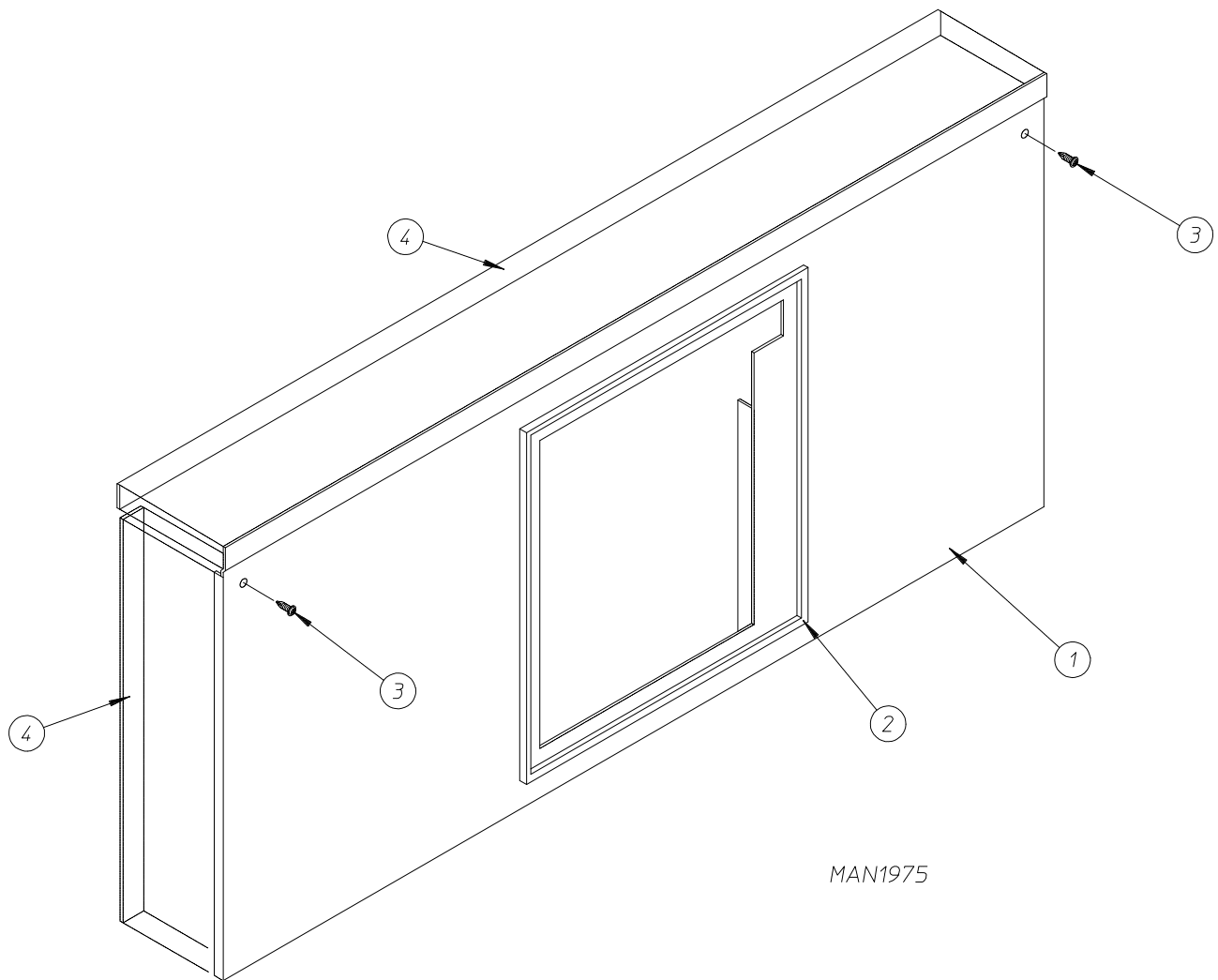

<u>Illus. No.</u>	<u>Part No.</u>	<u>Qty.</u>	<u>Description</u>
1	882497	1	White Lint Door Assembly (includes illus. nos. 1, 2, and 4)
	882497	1	Coral Wrinkle Blue Lint Door Assembly (includes illus. nos. 1, 2, and 4)
2	117605	5	Neoprene Sponge Tape (sold by the foot) (for models mfd. as of July 13, 1998)
	117602	5	Noise Suppressor Tape (sold by the foot) (for models mfd. prior to July 13, 1998)
3	150309	5	#10-16 x 1/2" Hex Head TEK Crimptite Screw
4	117604	5	Neoprene Sponge Tape (sold by the foot) (for models mfd. as of July 13, 1998)
	117600	9	Noise Suppressor Tape (sold by the foot) (for models mfd. prior to July 13, 1998)

for models mfd. as of September 1999

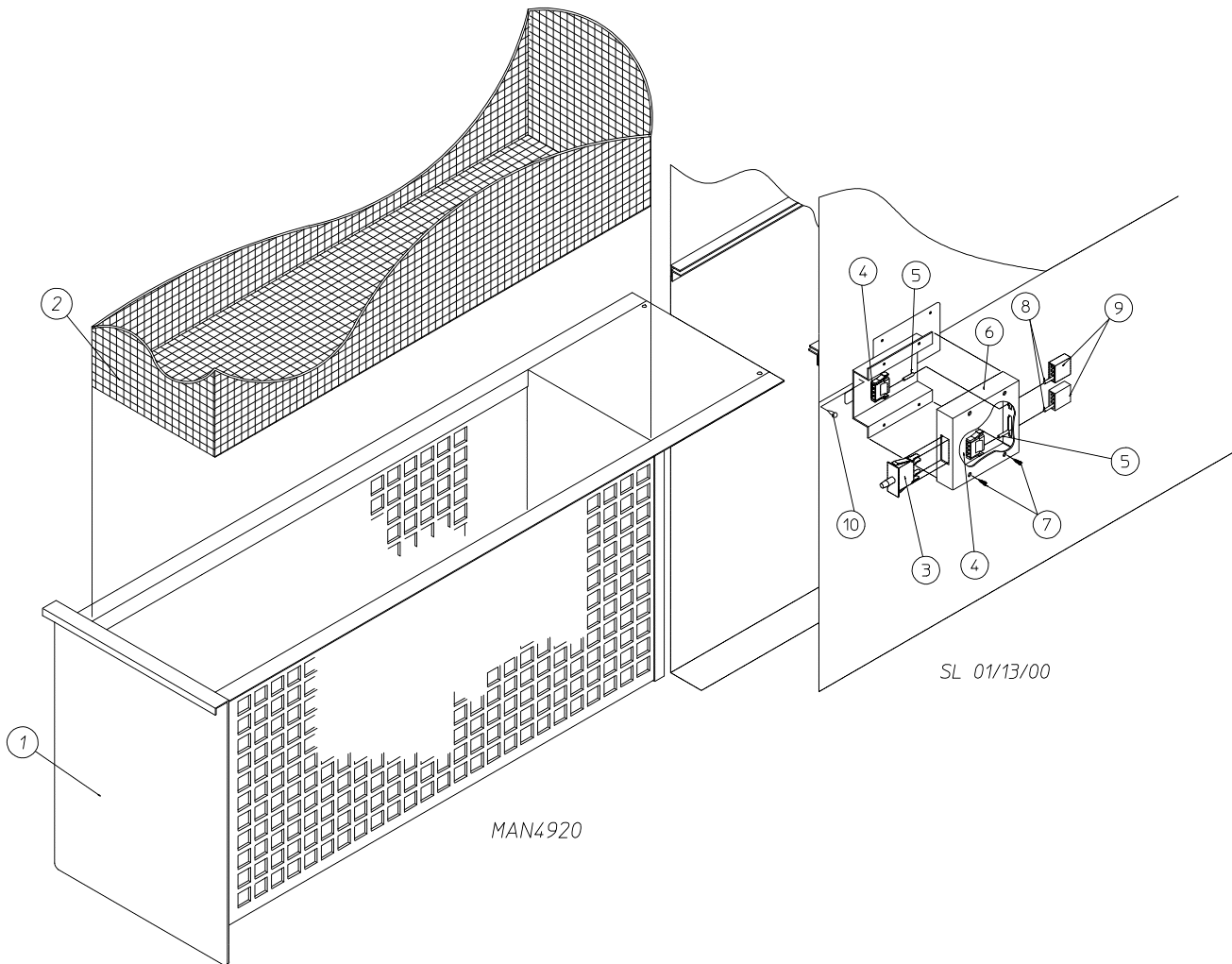

<u>Illus. No.</u>	<u>Part No.</u>	<u>Qty.</u>	<u>Description</u>
1	882449	1	White Lint Drawer Assembly Complete (includes illus. nos. 1 and 2)
	882450	1	Coral Wrinkle Blue Lint Drawer Assembly Complete (includes illus. nos. 1 and 2)
2	820925	1	Lint Screen Assembly ONLY
3	122116	1	Lint Drawer Switch ONLY
4	122605	2	4-Pin Socket Connector
5	122701	8	Socket Terminal ONLY
	122801	1	Pin/Socket Extraction Tool
6	800264	1	Lint Drawer Switch Box Assembly Complete (includes illus. nos. 3 through 6)
7	150301	4	#8-18 x 7/16" Phillips Pan Head TEK Screw
8	122700	8	Pin Terminal ONLY
9	122604	2	4-Pin Connector
10	150301	2	#8-18 x 7/16" Phillips Pan Head TEK Screw

for models mfd. prior to September 1999

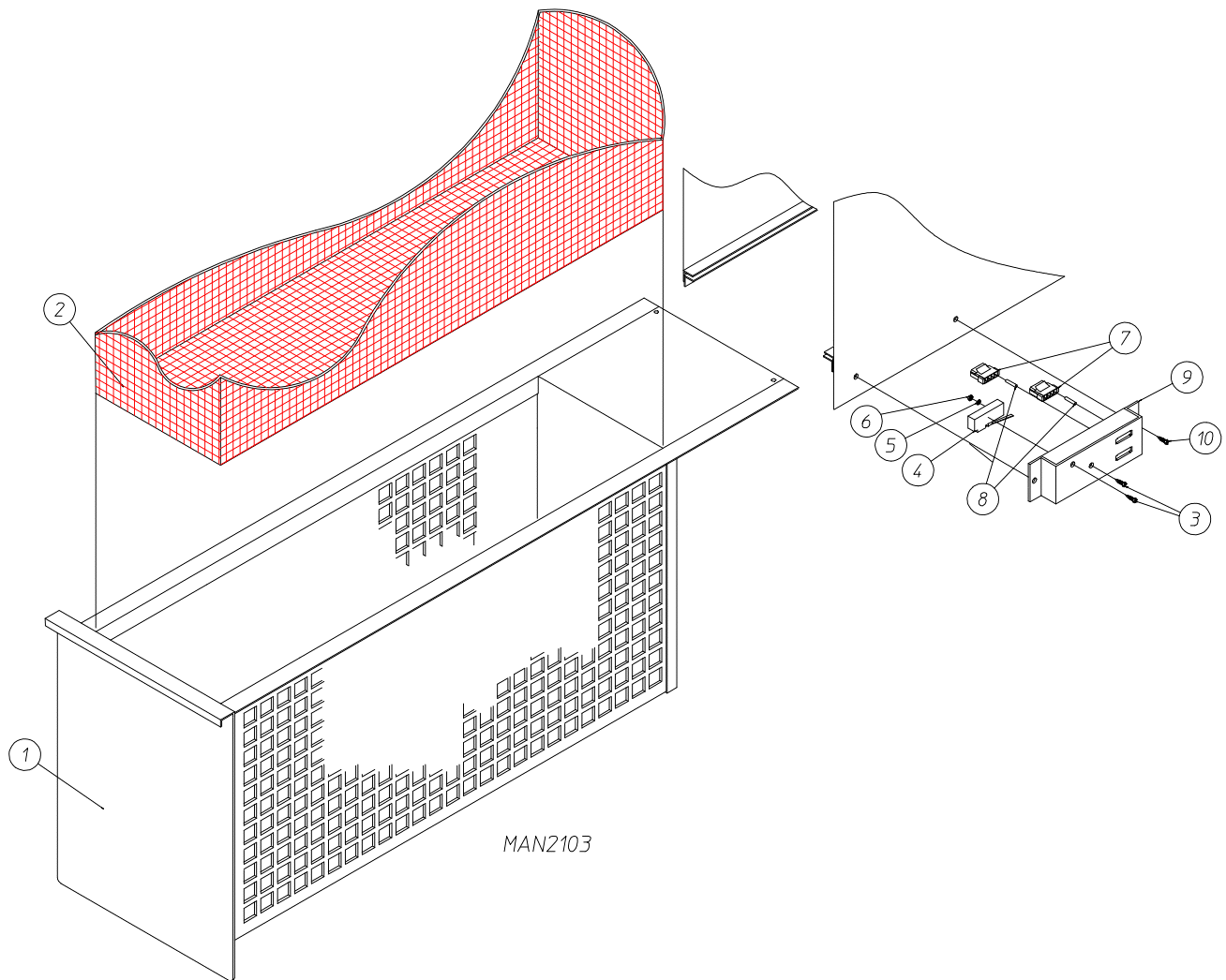

<u>Illus. No.</u>	<u>Part No.</u>	<u>Qty.</u>	<u>Description</u>
1*	821046	1	Lint Drawer Assembly
2	820925	1	Lint Screen Assembly ONLY
3	150002	2	#6-32 x 1" Phillips Round Head Machine Screw
4	136992	1	Lint Drawer Switch ONLY
5	153010	2	#6 Star Washer
6	152000	2	#6-32 Hex Nut
7	122605	2	4-Pin Socket Connector ONLY
8	122701	4	Socket Terminal ONLY
	122801	1	Pin/Socket Extraction Tool
9	821119	1	Lint Drawer Switch Assembly Complete (includes illus. nos. 3 through 10)
	821116	1	Lint Drawer Switch Mounting Bracket Assembly ONLY (includes illus. nos. 3 and 4)
	332348	1	Lint Drawer Switch Mounting Bracket ONLY
10	150309	2	#10-16 x 1/2" Hex Head TEK Crimptite Screw

* Specify color when ordering.

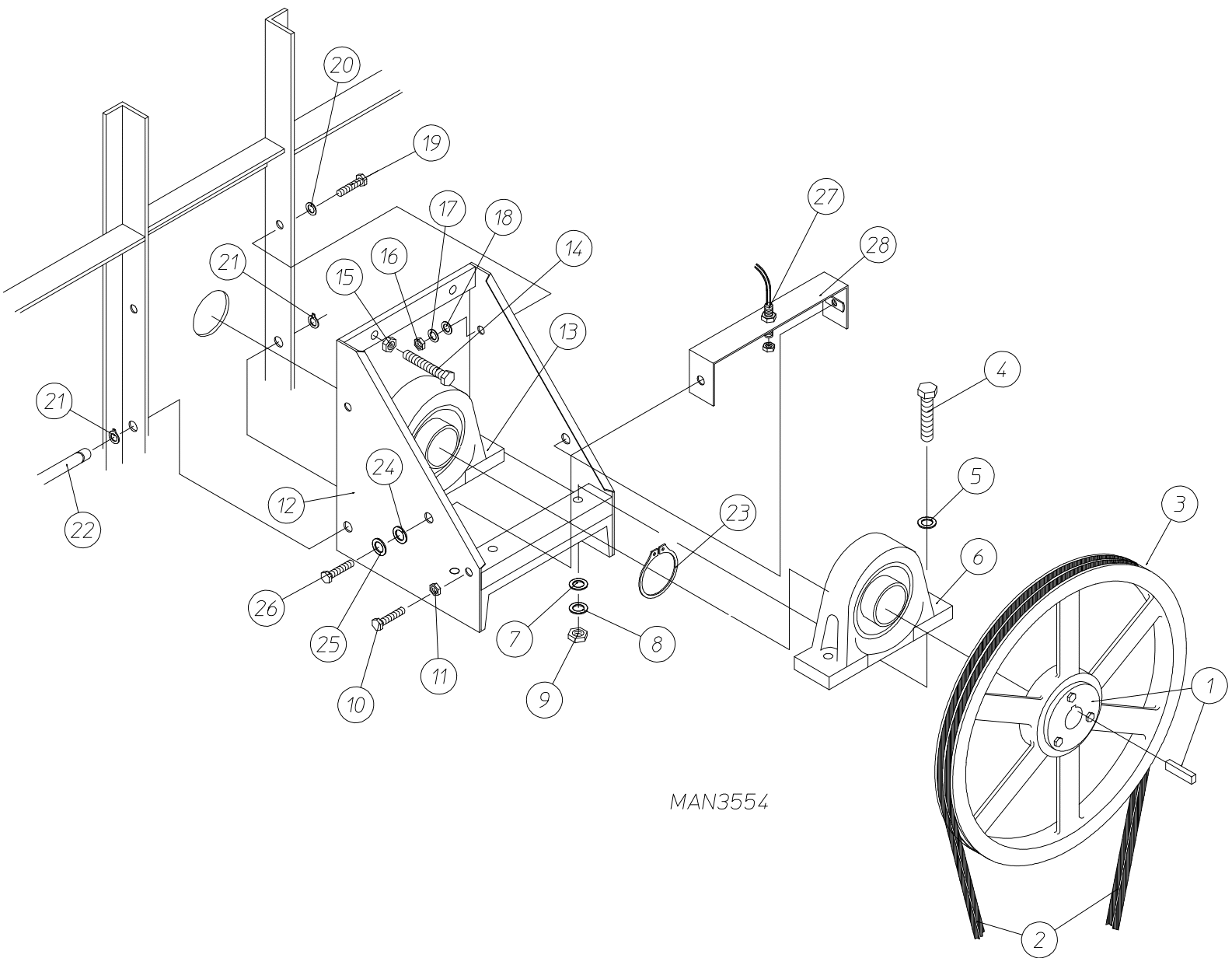

MAN3554

<u>Illus. No.</u>	<u>Part No.</u>	<u>Qty.</u>	<u>Description</u>
1	101217	1	2-1/2" SF Bushing with Key
2*	100137	2	AB-91 V-Belt
3	101182	1	25" Basket (Tumbler) Pulley ONLY
4	150602	4	5/8-11 x 3" Hex Head Machine Bolt
5	153016	4	5/8" Flat Washer
6	881775	1	2-1/2" Pillow Blocking Bearing with Nylock Set Screws (for models mfd. as of August 27, 1997)
	880883	1	3-1/8" Pillow Blocking Bearing with Nylock Set Screws (for models mfd. prior to August 27, 1997)
7	153016	4	5/8" Flat Washer
8	153015	4	5/8" Lock Washer
9	152010	4	5/8-11 Hex Nut
10	150600	2	3/8-16 x 1-1/2" Hex Head Machine Bolt
11	152005	2	3/8-16 Hex Nut
12	821175	1	Tumbler Bearing Mount ONLY (for models mfd. as of August 27, 1997)
	820910	1	Tumbler Bearing Mount ONLY (for models mfd. prior to August 27, 1997)
13	880883	1	3-1/8" Pillow Block Bearing with Nylock Set Screws
14	150604	2	1/2-20 x 3" Square Head Machine Bolt
15	152012	2	1/2-20 Hex Nut
16	152005	2	3/8-16 Hex Nut
17	153005	2	3/8" Lock Washer
18	153004	4	3/8" Flat Washer
19	150600	2	3/8-16 x 1-1/2" Hex Head Machine Bolt
20	153004	2	3/8" Flat Washer
21	100801	2	5/8" Retaining Ring
22	332153	1	5/8" Hinge Pin
23	100810	2	3-1/8" Retaining Ring
24	153018	2	1/4" Flat Washer
25	153007	2	1/4" Lock Washer
26	150512	2	1/4-20 x 1/2" Hex Head Machine Bolt
27	824807	1	Rotational Sensor Assembly
28	880841	1	Rotational Sensor Mounting Bracket

* Replace in match sets (both belts).

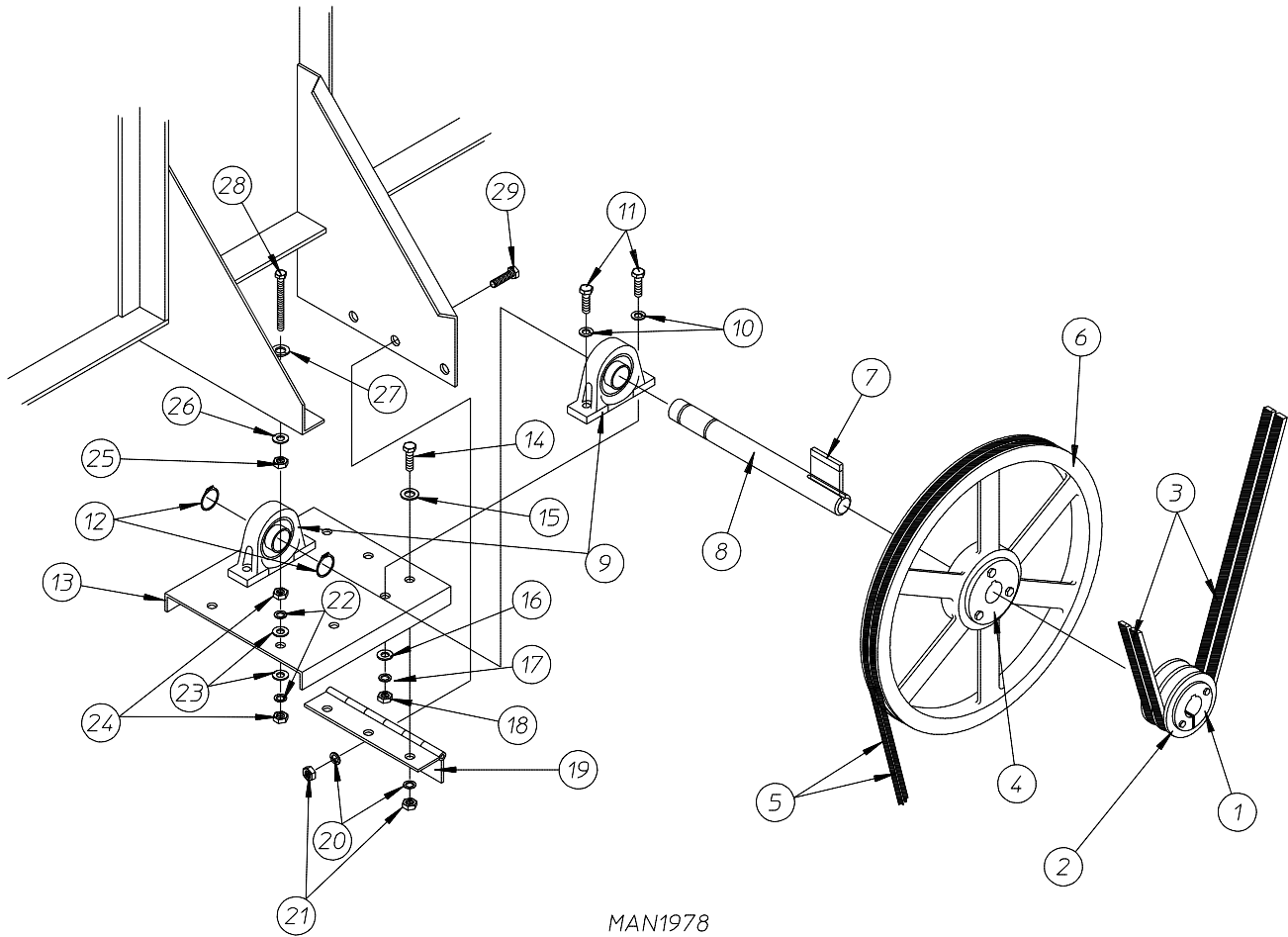

<u>Illus. No.</u>	<u>Part No.</u>	<u>Qty.</u>	<u>Description</u>
1	101152	1	SH x 1-3/8" Bushing
2	101143	1	2B x 3.8 Pulley
3*	100137	2	AB-91 "V" Belt
4	101184	1	SK x 1-3/8" Bore Bushing
5*	100102	2	3V-740 "V" Belt
6	101112	1	19" Idler Pulley ONLY
7	100730	1	5/16" X 5/16" x 4" Key
8	332152	1	Idler Shaft ONLY
9	881644	2	1-3/8" Pillow Block Bearing with Set Screws
10	153011	4	9/16" Flat Washer
11	150606	4	1/2-13 x 2" Hex Head Machine Bolt
12	100802	2	1-3/8" Retaining Ring
13	820932	1	Idler Bearing Mount Assembly Complete (includes illus. nos. 8 through 11 and 17 through 25)
	332151	1	Idler Bearing Mount ONLY
14	150501	3	5/16-18 x 3/4" Hex Head Machine Bolt
15	153001	3	5/16" Flat Washer
16	153011	4	9/16" Flat Washer
17	153026	4	1/2" Lock Washer
18	152011	4	1/2-13 Hex Nut
19	103005	1	Idler Adjustment Hinge ONLY
20	153002	6	5/16" Lock Washer
21	152004	6	5/16-18 Hex Nut
22	153005	4	3/8" Lock Washer
23	153004	4	3/8" Flat Washer
24	152005	4	3/8-16 Hex Nut
25	152005	2	3/8-16 Hex Nut
26	153005	2	3/8" Lock Washer
27	153005	2	3/8" Lock Washer
28	152034	2	3/8-16 x 3-1/2" Hex Head Bolt
29	150501	3	5/16-18 x 3/4" Hex Head Machine Bolt

* Replace in matched sets (both belts).

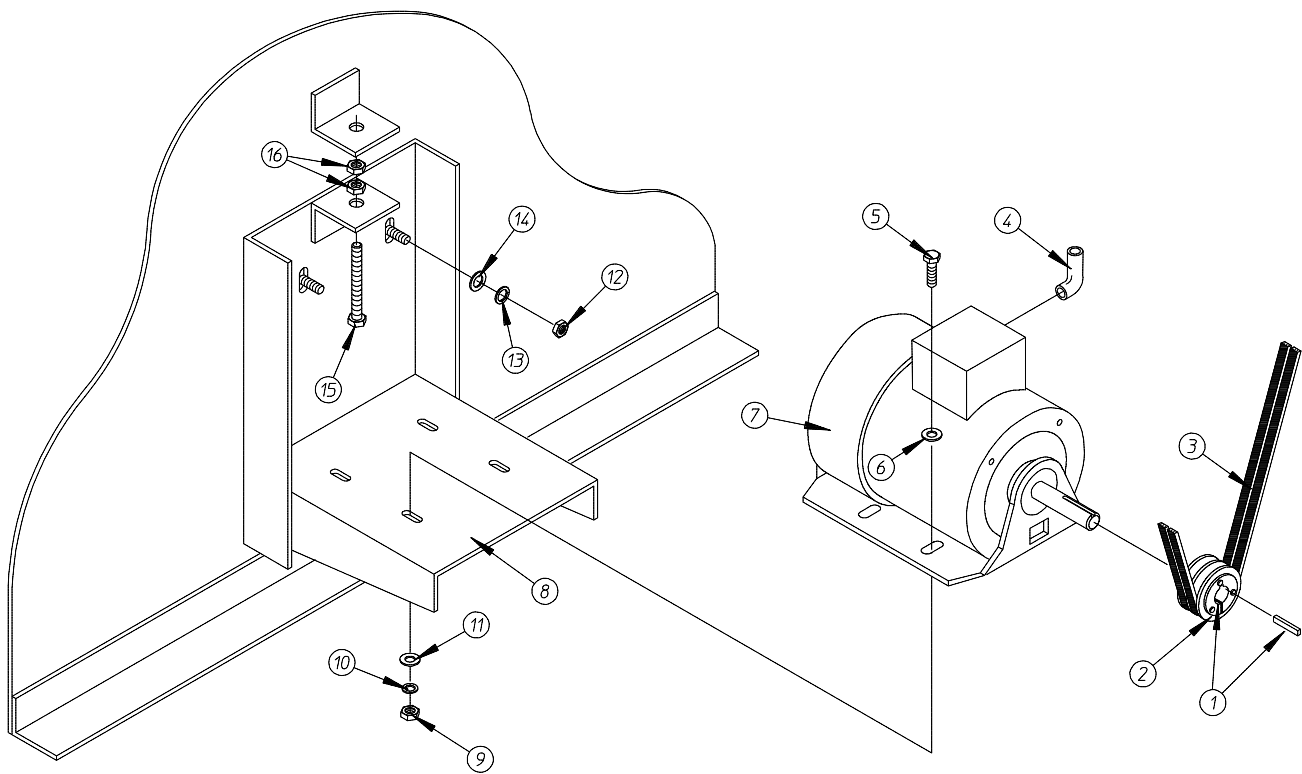

MAN0329

<u>Illus. No.</u>	<u>Part No.</u>	<u>Qty.</u>	<u>Description</u>
1	101121	1	5/8" SK Bushing
2	101114	1	2.65" Pulley (for <u>60 Hz Models ONLY</u>)
	101120	1	3.15" Pulley (for <u>50 Hz Models ONLY</u>)
3*	100102	2	3V-740 V-Belt
4	120200	1	3/8" x 90° Connector
5	150501	4	5/16-18 x 3/4" Hex Head Machine Bolt
6	153001	4	5/16" Flat Washer
7	100050	1	1 HP 208/230/380/460v 3ø 50/60 Hz T.E.F.C. Motor (56Z frame)
8	800952	1	Basket (Tumbler) Motor Mount (56Z frame)
	820941**	1	(50/60 Hz) T.E.F.C. Basket (Tumbler) Motor Mount Assembly Complete (includes illus. nos. 1,4 through 11, 15 and 16)
			<u>NOTE: MOTOR PULLEY MUST BE ORDERED SEPARATELY</u>
9	152004	4	5/16-18 Hex Nut
10	153002	4	5/16" Lock Washer
11	153001	4	5/16" Flat Washer
12	152004	4	5/16-18 Hex Nut
13	153002	4	5/16" Lock Washer
14	153001	4	5/16" Flat Washer
15	150619	1	3/8-16 x 3" Hex Head Machine Bolt
16	152005	2	3/8-16 Hex Nut

* Replace in matched sets (both belts).

** Specify color when ordering.

IMPORTANT: For voltages higher than 460v, contact the factory for correct part number of motor or motor mount assembly.

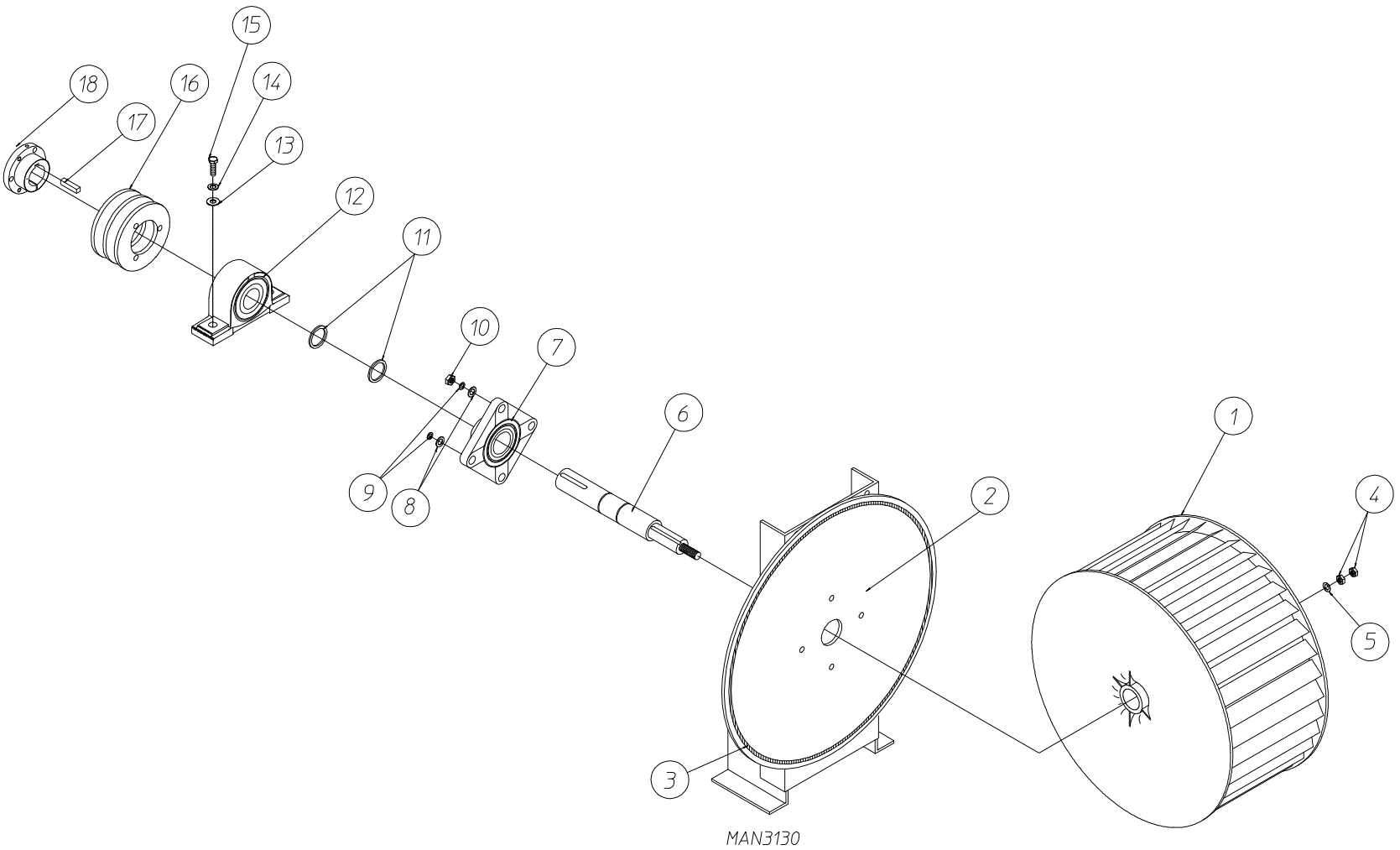

<u>Illus. No.</u>	<u>Part No.</u>	<u>Qty.</u>	<u>Description</u>
1	100612	1	1-1/4" Bore x 15" Diameter x 6" Blower/Fan (Squirrel Cage)
2	821078	1	Fan Shaft Mount Assembly Complete (includes illus. nos. 1 through 18)
	821073	1	Fan Shaft Mount ONLY
3	117604	5	Neoprene Sponge Tape (sold in feet) (for models mfd. as of July 13, 1998)
	117600	9	Noise Suppressor Tape (sold in feet) (for models mfd. prior to July 13, 1998)
4	152006	2	1/2-20 Left Hand Jam Nut
5	153065	1	1/2" Flat Washer
6	332280	1	Fan Shaft ONLY
7	881061	1	1-3/8" Flange Bearing with Set Screws and Grease Fitting
8	153004	4	3/8" Flat Washer
9	153005	4	3/8" Lock Washer
10	152005	4	3/8-16 Hex Nut
11	100812	2	1-3/8" Retaining Ring
12	880879	1	1-3/8" Pillow Block Bearing ONLY
13	153004	2	3/8" Flat Washer
14	153005	2	3/8" Lock Washer
15	150617	2	#3-16 x 1" Hex Head Bolt
16	101177	1	2B x 5.8 Pulley (for Gas Models Only)
	101135	1	2B x 5.4 Pulley (for Steam Models Only)
17	100706	1	5/16" x 5/16" x 1-3/8" Key
18	101194	1	SDS x 1-3/8" Bushing ONLY

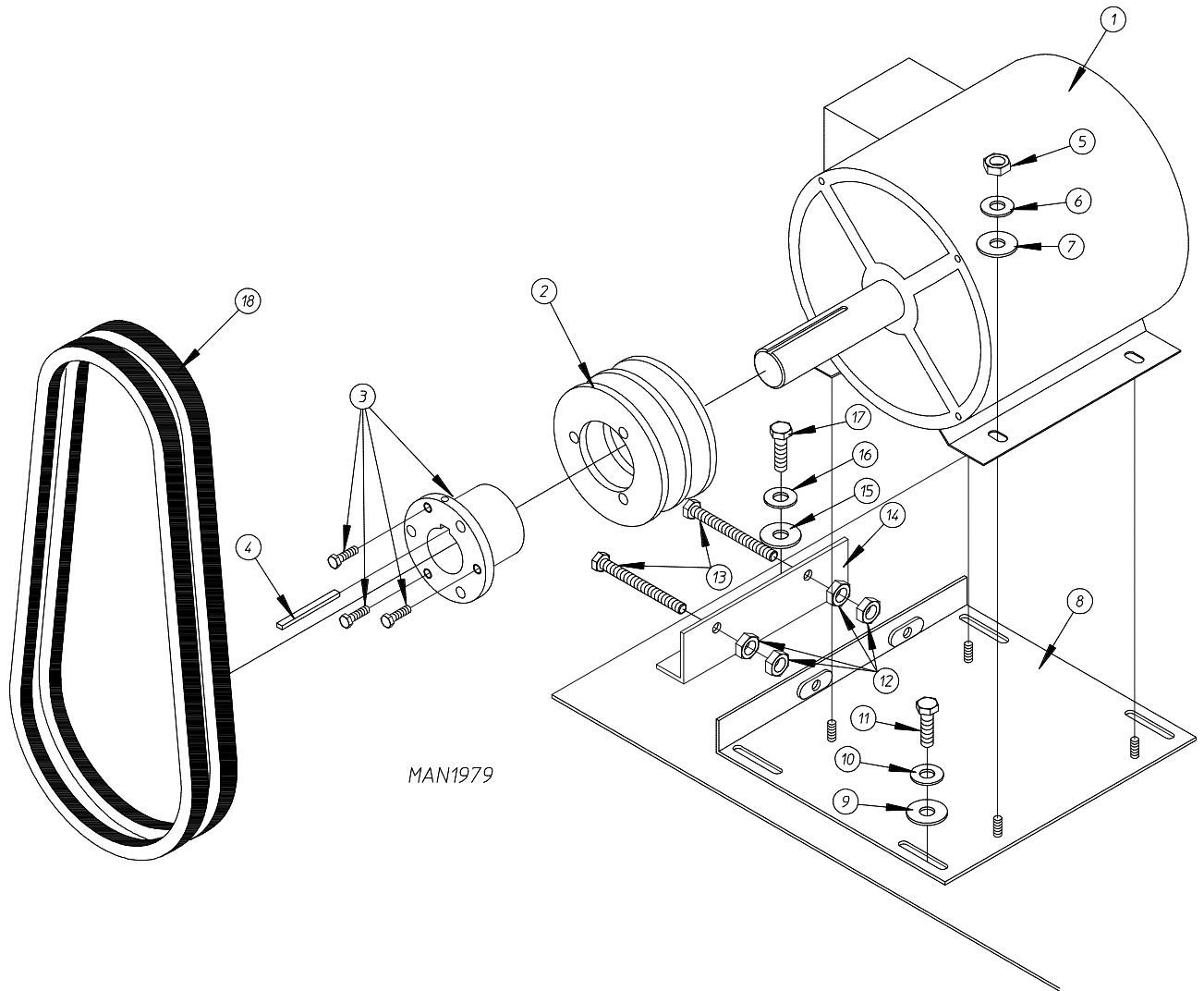

MAN1979

<u>Illus. No.</u>	<u>Part No.</u>	<u>Qty.</u>	<u>Description</u>
1	100046	1	7.5 HP 208-230/460v 3 ϕ Motor (for 60 Hz Models Only)
	100092	1	7.5 HP 230/460v 3 ϕ Motor (for 50 Hz Models Only)
2	101148	1	SB x 4.0 Motor Pulley (for 60 Hz Models Only)
	101147	1	SB x 4.8 Motor Pulley (for 50 Hz Models Only))
3	101152	1	SH x 1-3/8" Bushing (for 60 Hz Models Only)
	101194	1	SDS x 1-3/8" Bushing (for 50 Hz Models Only)
4	100706	1	5/16" x 5/16" x 1-3/8" Key
5	152004	4	5/16-18 Hex Nut
6	153002	4	5/16" Lock Washer
7	153001	4	5/16" Flat Washer
8	821091	1	Motor Mount Adjustment Plate ONLY
9	153001	4	5/16" Flat Washer
10	153002	4	5/16" Lock Washer
11	150501	4	5/16-18 x 3/4" Hex Head Machine Bolt
12	152004	4	5/16-18 Hex Nut
13	150503	2	5/16-18 x 2" Hex Head Machine Bolt
14	332322	1	Motor Mount Adjustment Angle ONLY
15	153001	2	5/16" Flat Washer
16	153002	2	5/16" Lock Washer
17	150501	2	5/16-18 x 3/4" Hex Head Machine Bolt
18*	100128	2	BX-50 Cogged Belt (for 60 Hz Models Only)
	100164	2	BX-51 Cogged Belt (for 50 Hz Models Only)

* Replace in matched sets (both belts).

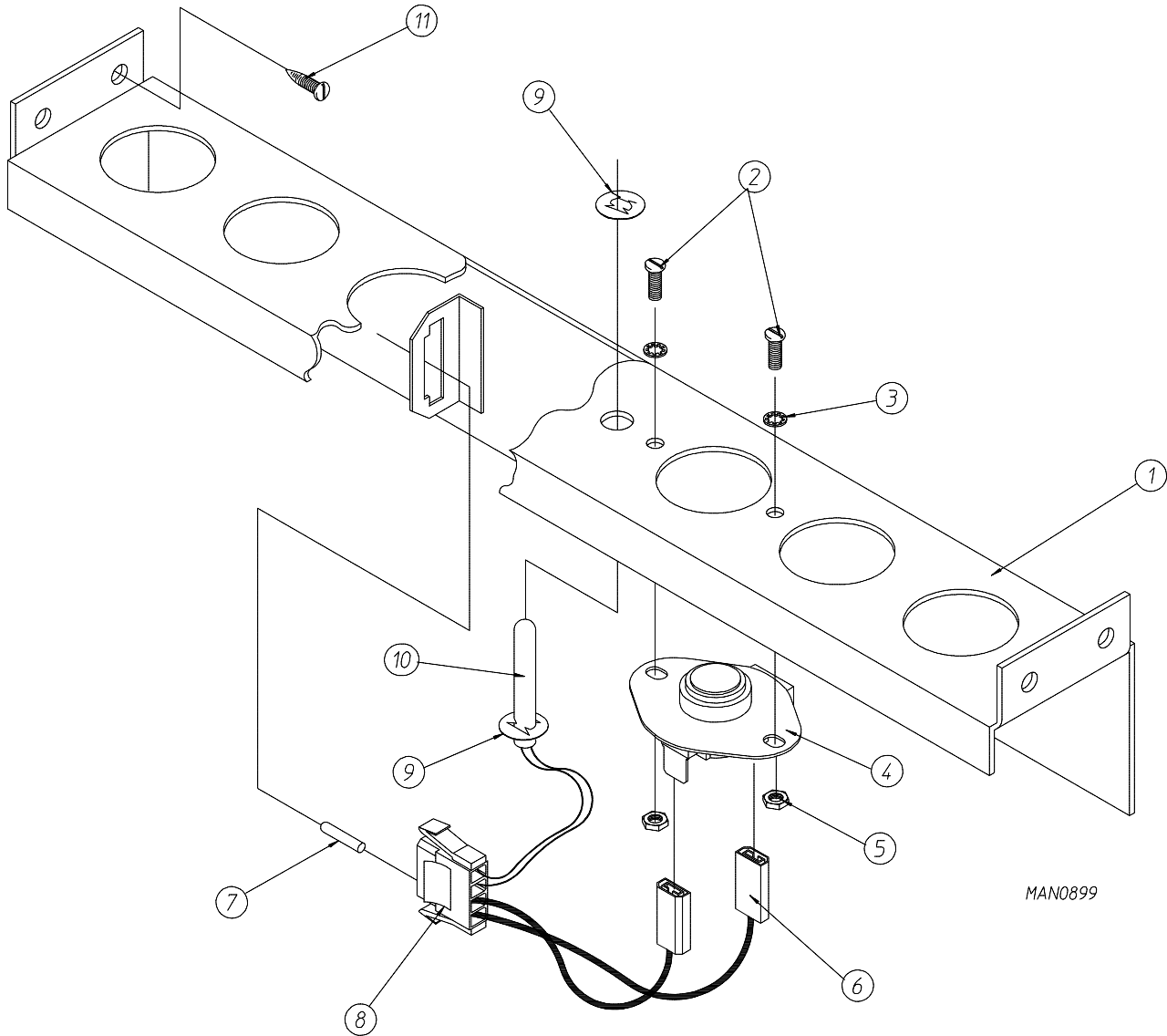

MAN0899

<u>Illus. No.</u>	<u>Part No.</u>	<u>Qty.</u>	<u>Description</u>
1	820968	1	Microprocessor Temperature Sensor Bracket Complete (includes illus. nos. 1 through 10)
	820967	1	Microprocessor Temperature Sensor Bracket ONLY
2	150005	2	#6-32 x 1/4" Round Head Machine Screw
3	153010	2	#6 Star Washer
4	130301	1	225° Manual Reset Thermostat ONLY
5	152000	2	#6-32 Hex Nut
6	121028	2	1/4" x .032 Insulated Terminal
7	122701	4	Socket Terminal ONLY
8	122605	1	4-Pin Socket Connector
9	154007	2	1/4" Push-On Fastener
10	880251	1	1/4" Temperature Sensor Probe Assembly (includes illus. nos. 6 through 10)
11	150301	4	#8-18 x 7/16" Phillips Pan Head TEK Screw

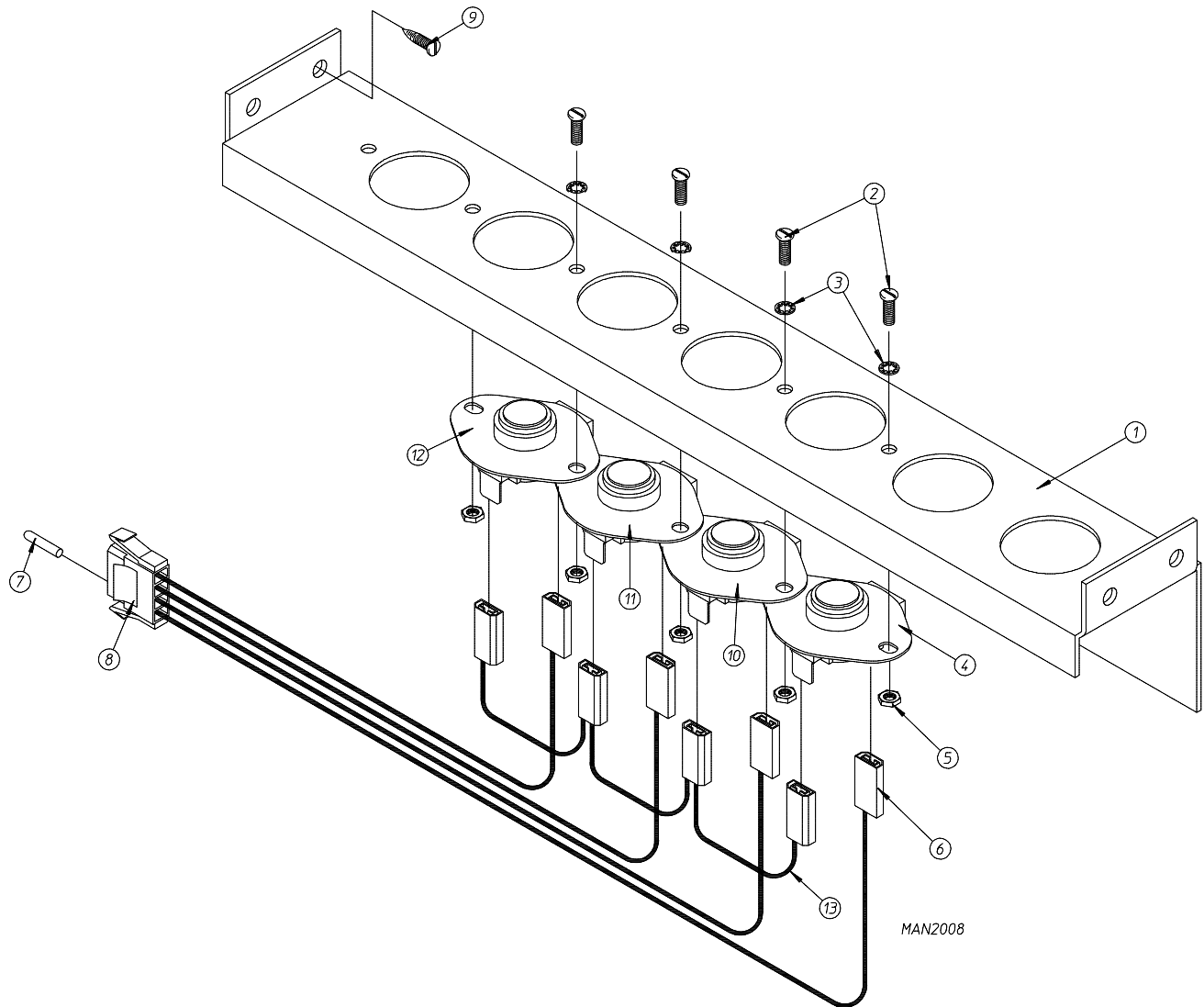

<u>Illus. No.</u>	<u>Part No.</u>	<u>Qty.</u>	<u>Description</u>
1	821016	1	Timer Temperature Sensor Bracket Complete (includes illus. nos. 1 through 13)
	820999	1	Timer Temperature Sensor Bracket ONLY
2	150005	5	#6-32 x 1/4" Round Head Machine Screw
3	153010	5	#6 Star Washer
4	130101	1	180° Thermostat ONLY
5	152000	2	#6-32 Hex Nut
6	121028	4	1/4" x .032 Insulated Terminal
7	122701	4	Socket Terminal ONLY
8	122605	1	4-Pin Socket Connector
9	150301	4	#8-18 x 7/16" Phillips Pan Head TEK Screw
10	130109	1	140° Thermostat ONLY
11	130107	1	160° Thermostat ONLY
12	130103	1	225° Manual Reset Thermostat ONLY
13	831701	1	Sensor Jumper (4) ONLY

for Gas Models ONLY

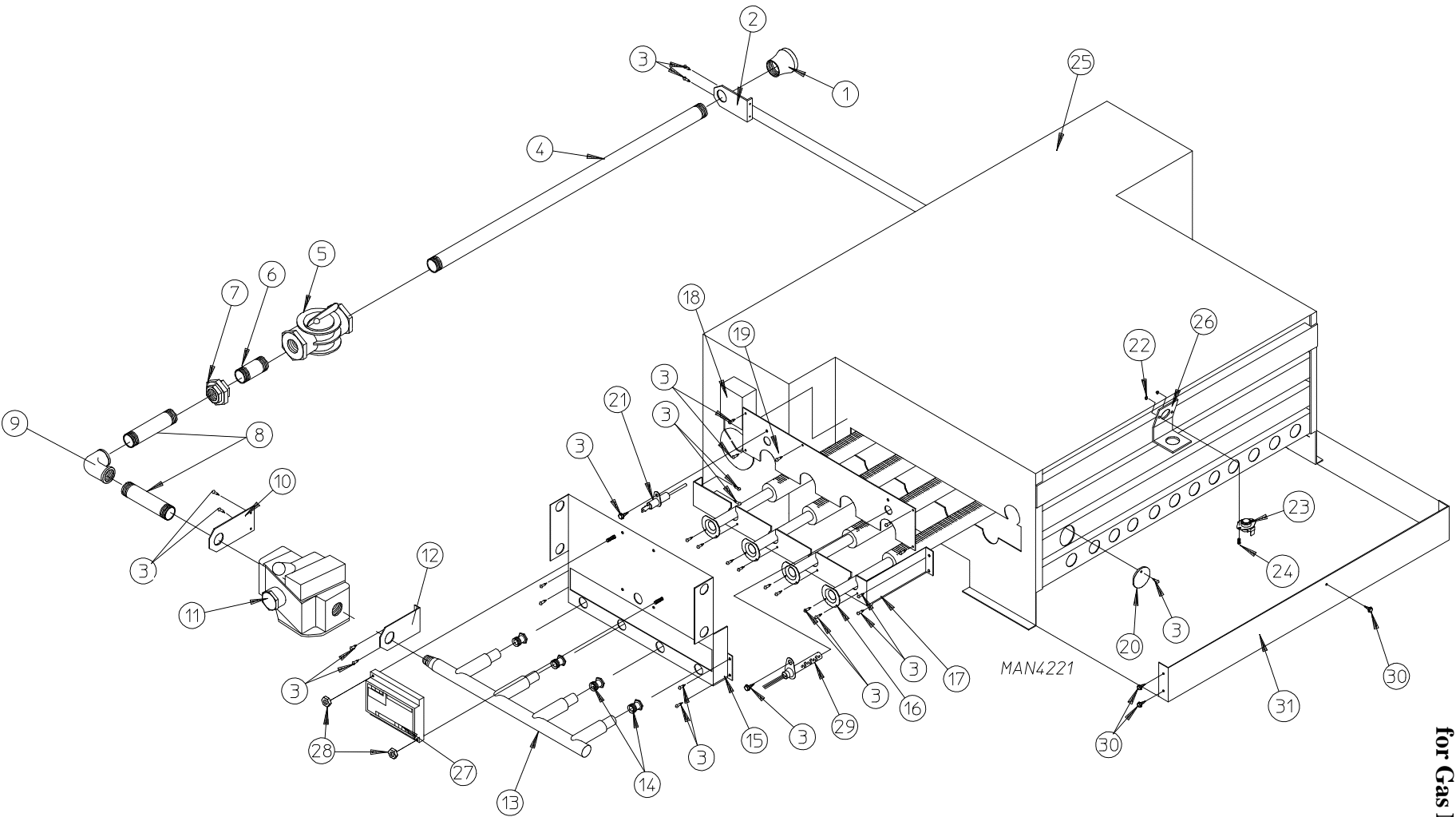

for Gas Models ONLY

<u>Illus. No.</u>	<u>Part No.</u>	<u>Qty.</u>	<u>Description</u>
1	142929	1	1-1/2" to 1" Reducing Coupling
2	332117	1	Pipe Bracket
3	150309	33	#10-16 x 1/2" Hex Head TEK Crimptite Screw
4	142817	1	1" x 28-1/2" Pipe
5	141302	1	1" Union Shutoff
6	142724	1	1" x 2" Nipple
7	142602	1	1" Union
8	142581	2	1" x 5" Nipple
9	142548	1	1" x 90° Elbow
10	332487	1	Gas Valve Pipe Bracket
11	140017	1	1" x 1" 24 VAC Redundant (natural gas) Gas Valve ONLY
	140018	1	1" 24 VAC Gas Valve L.P. Conversion Kit
12	332486	1	Gas Valve Pipe Bracket
13	141240	1	4-Port Manifold ONLY
14*	140839	4	#2 Burner Orifice (natural gas) ONLY
	140820	4	#29 Burner Orifice (liquid propane [L.P.]) ONLY
15	390169	1	Hot Surface Ignition (HSI) Module Mounting Bracket/Manifold Rest
16	141110	4	Burner Tube ONLY
17	332121	1	Burner Tube Support ONLY
18	-----	1	Sail Switch (refer to Sail Switch Assembly on page 30)
19	390170	1	HSI (Hot Surface Ignition) Burner Box Cover Plate ONLY
20	331290	1	Sight Hole Disc ONLY
21	128921	1	HSI (Hot Surface Ignition) Flame Sensor
22	151000	2	#6-32 Pal Nut
23	130201	1	330° Manual Reset Hi-Limit Thermostat ONLY
24	150001	2	#6-32 x 1/2" Round Head Machine Screw
25	881801**	1	Natural Gas Burner Assembly Complete Less Orifices (includes illus. nos. 1 through 13 and 15 through 28) For models mfd. with Natural Gas ONLY
	881802**	1	Liquid Propane (L.P.) Gas Burner Assembly Complete less Orifices (includes illus. nos 1 through 13 and 15 through 28) For models mfd. with Liquid Propane (L.P.) Gas ONLY
	820904	1	Burner Box ONLY
	880978*	1	Hot Surface Ignition (HSI) L.P. Conversion Kit
26	821457	1	Hi-Limit Mounting Bracket ONLY
27	881797	1	HSI (Hot Surface Ignition) Module II
28	151001	2	#8-32 Pal Nut
29	881597	1	Hot Surface Ignitor - 24 VAC
30	150309	1	#10-16 x 1/2" Hex Head TEK Crimptite Screw
31	332256	1	Liquid Propane (L.P.) Burner Baffle

* Consult factory for elevations over 2,000 feet.

** Orifices *are not included* and **must be** ordered separately.

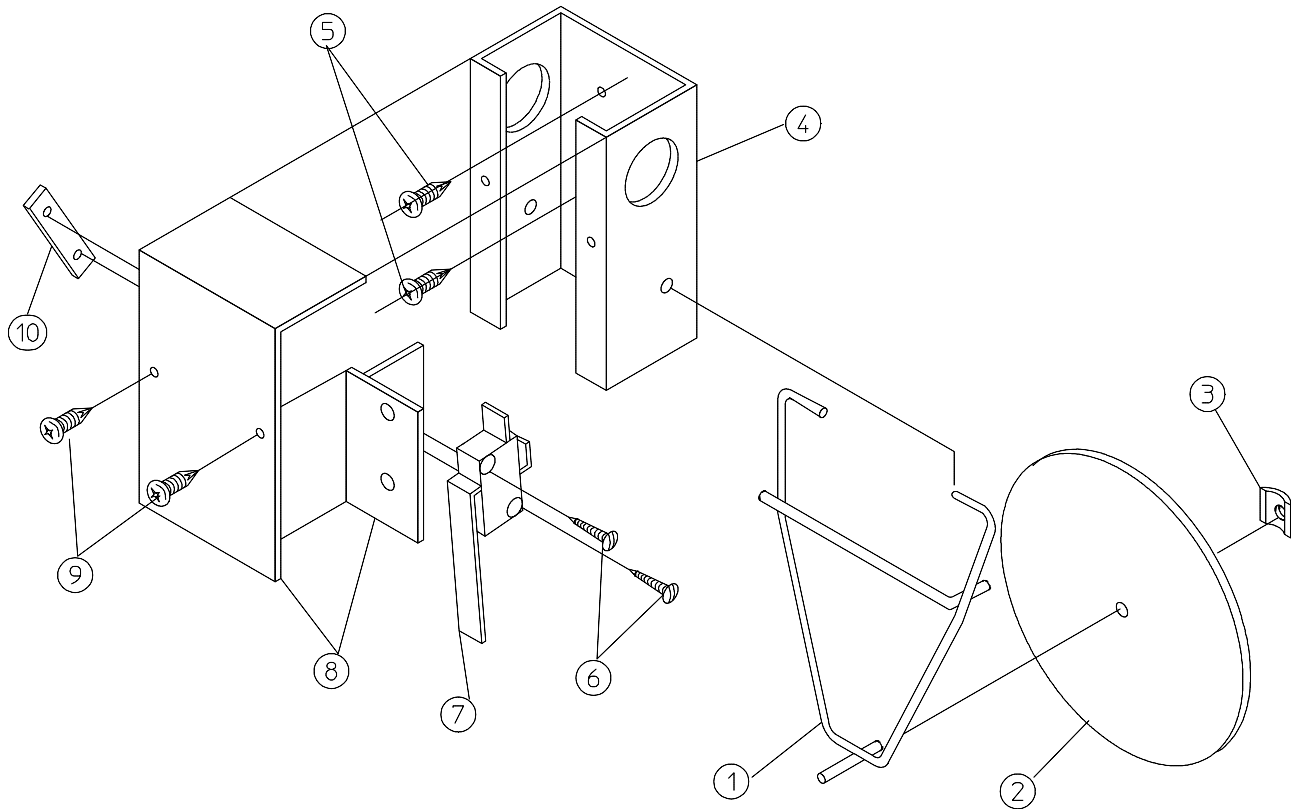

MAN0440

<u>Illus. No.</u>	<u>Part No.</u>	<u>Qty.</u>	<u>Description</u>
1	105500	1	Sail Switch Actuator Rod
2	319202	1	Sail Switch Damper (flat)
3	154002	1	1/8" Push-On Fastener
4	802800	1	Sail Switch Box with Cover and Bracket ONLY
	802801	1	Sail Switch Box Assembly Complete (includes illus. nos. 1 through 4 and 6 through 10) For Microprocessor (computer) Models ONLY
	882010	1	Sail Switch Box Assembly Complete (includes illus. nos. 1 through 4 and 6 through 10) For Dual Timer Models ONLY
5	150300	2	#10 x 1/2" Hex Washer TEK Screw
6	150303	2	#4 x 3/4" Pan Head "A" Machine Screw
7	122200	1	Sail Switch ONLY (for Microprocessor [computer] Models Only)
	122404	1	Sail Switch ONLY (for Dual Timer Models Only)
8	802799	1	Sail Switch Box Cover and Bracket ONLY
9	150309	2	#10-16 x 1/2" Hex Head TEK Crimptite Screw
10	154004	1	Twin Speed Nut

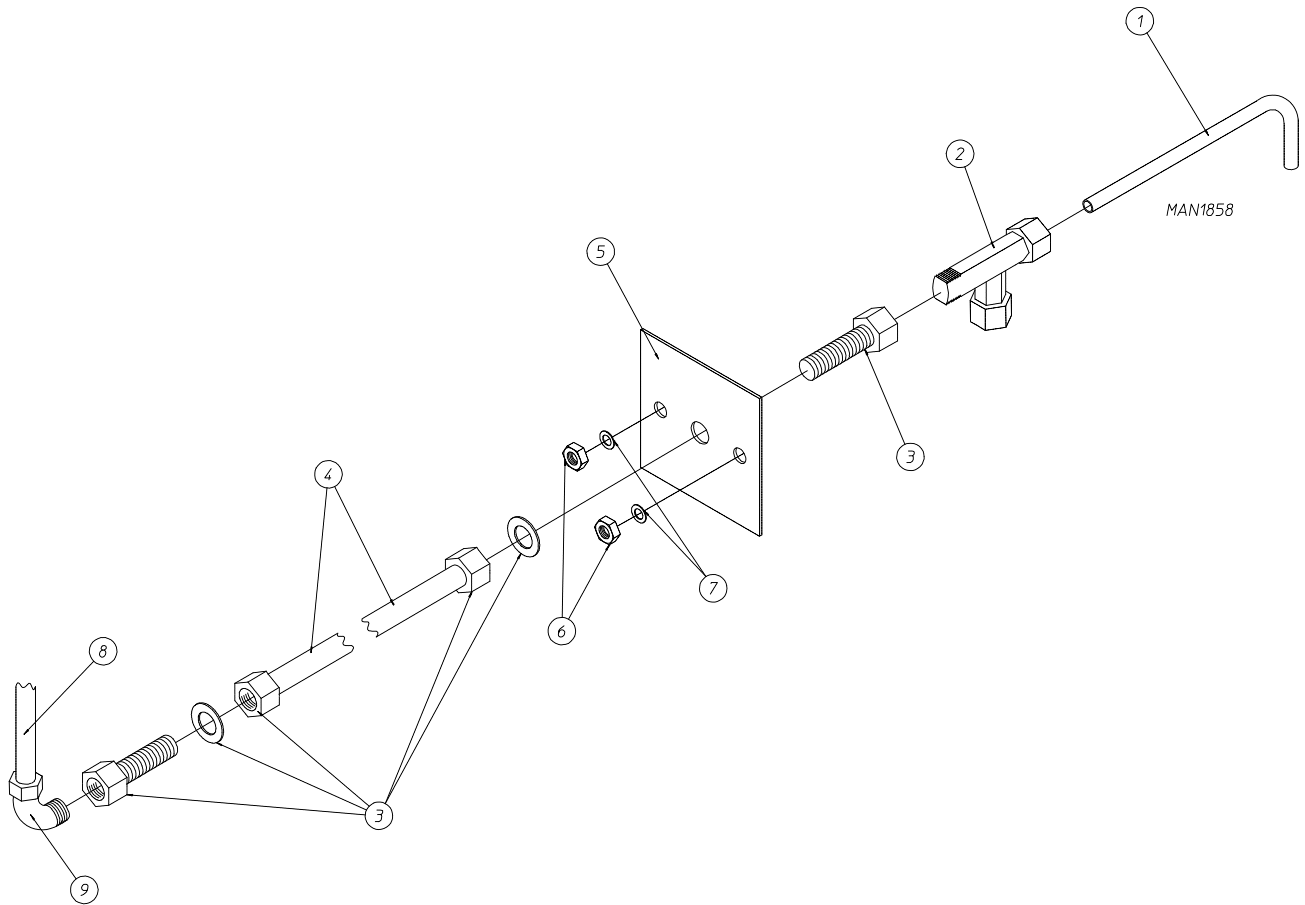

<u>Illus. No.</u>	<u>Part No.</u>	<u>Qty.</u>	<u>Description</u>
1	332700	1	Air Jet Tube ONLY
2	143287	1	1/4" x 1/8" M.P.T. Male Run Tee
3	143259	2	1/4" x 1/8" F.P.T. Bulkhead Fitting
4	143100	3	1/4" Aluminum Tube (sold in feet)
5	821081	1	Air Jet Mounting Plate ONLY (includes illus. nos. 1 through 9)
	332531	1	Air Jet Mounting Plate ONLY
6	152002	2	1/4-20 Hex Nut
7	153007	2	1/4" Lock Washer
8	143110	5	1/4" Poly Flow Tubing (sold in feet)
9	143149	1	1/4" x 1/8" M.P.T. 90° Elbow

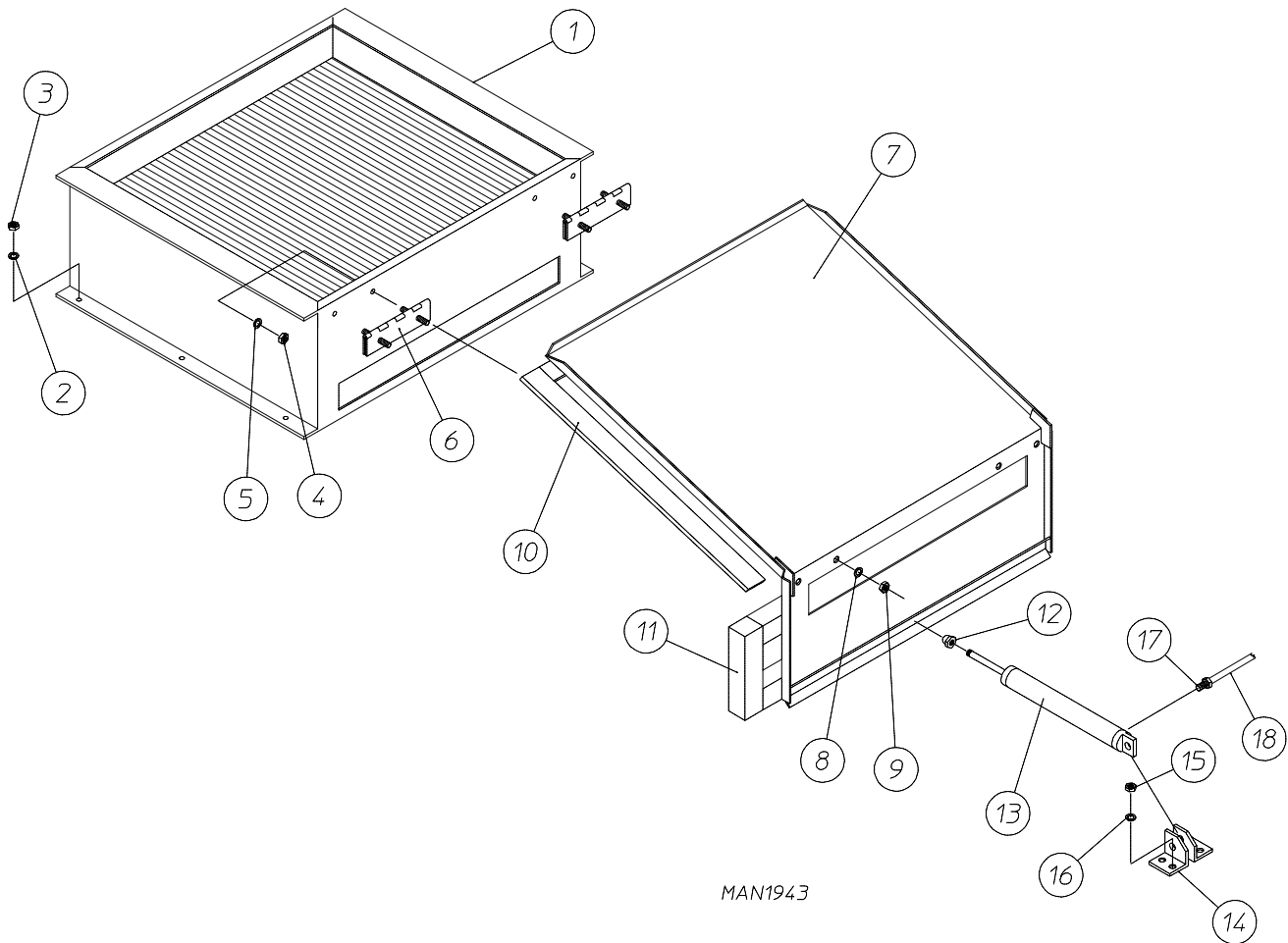

for Steam Models ONLY

<u>Illus. No.</u>	<u>Part No.</u>	<u>Qty.</u>	<u>Description</u>
1	165017	1	Steam Coil ONLY
2	153002	6	5/16" Lock Washer
3	152004	6	5/16-18 Hex Nut
4	152002	4	1/4-20 Hex Nut
5	153007	4	1/4" Lock Washer
6	820321	2	Steam Damper Hinge Assembly
7	820994	1	Steam Damper Assembly (includes illus. nos. 7, 10, and 11)
8	153007	4	1/4" Lock Washer
9	152002	4	1/4-20 Hex Nut
10	115995	96	Steam Damper Gasket (sold by the inch)
11	102350	2	Steam Damper Foam (68-1/2" length)
12	151007	1	7/16-20 Stainless Steel Acorn Nut
13	100499	1	1-1/2" Bore x 3" Stroke Piston
14	100500	1	Piston Support Bracket
15	152002	4	1/4-20 Hex Nut
16	153007	4	1/4" Lock Washer
17	100472	1	1/4" x 1/8" Connector
18	143110	1	1/4" Tubing (sold by the foot) (refer to Top Console Assembly on <u>page 40</u> and <u>page 41</u>)

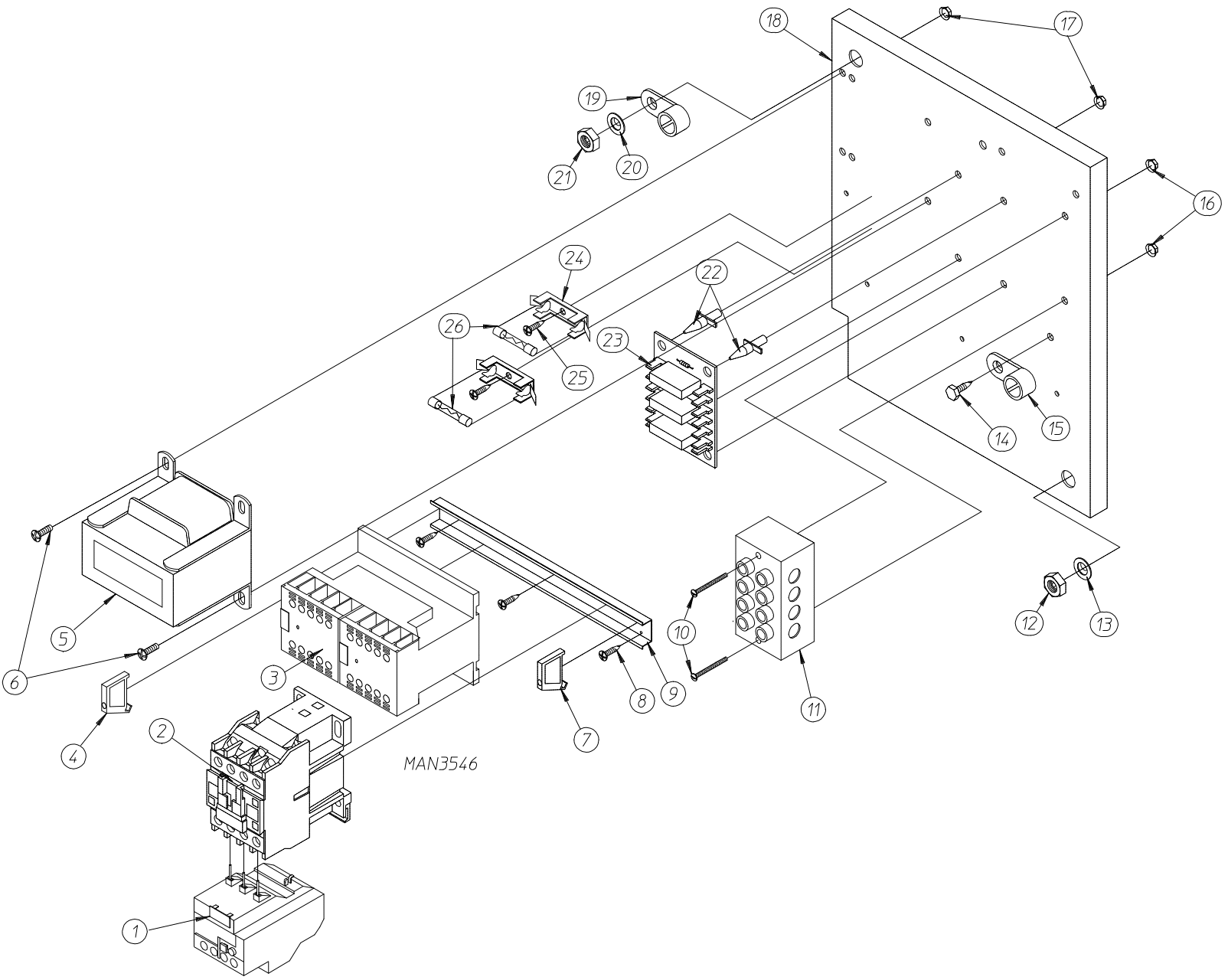

<u>Illus. No.</u>	<u>Part No.</u>	<u>Qty.</u>	<u>Description</u>
1	132439	1	17 - 25 Amp Blower (Impellor/Fan) Overload
2	132465	1	Reversing (Impellor/Blower/Fan) Contactor - 24 VAC
3	132448	1	Reversing Contactor - 24 VAC
4	120765	1	End Stop/Bracket
5*	842894	1	Phase 6 Hot Surface Ignition (HSI) Transformer (208 - 240 Volt / 3 ϕ)
6	150108	2	#8-32 x 1/2" Pan Head Machine Screw
7	120765	1	End Stop/Bracket
8	150301	3	#8-18 x 7/16" Phillips Pan Head TEK Screw
9	120768	8	Din Mounting Rail (sold by the inch)
10	150008	2	#6-32 x 1-1/4" Slotted Round Head Machine Screw
11	120701	1	4-Position Power Distribution Block
12	152004	1	#5/16-18 Hex Nut
13	153002	1	5/16" Lock Washer
14	150297	1	#10 x 1/2" Hex Washer TEK Screw
15	121010	1	L-70 Ground Lug
16	151000	2	#6-32 Pal Nut
17	151001	2	#8-32 Pal Nut
18	332346	1	Contactor/Relay Mounting Panel ONLY
19	121012	1	Terminal/Ground Lug
20	153002	1	5/16" Lock Washer
21	152004	1	5/16-18 Hex Nut
22	137013	4	Nylon Standoff
23	137060	1	Arc Suppressor Board (3)
24	136008	2	Fuse Block/Holder
25	150301	2	#8-18 x 7/16" Phillips Pan Head TEK Screw
26	136057	2	1/2-Amp (Slo-Blo) Fuse

* For 380 Volts or above, refer to the **Step Down Transformer Usage Listing** on **page 44**.

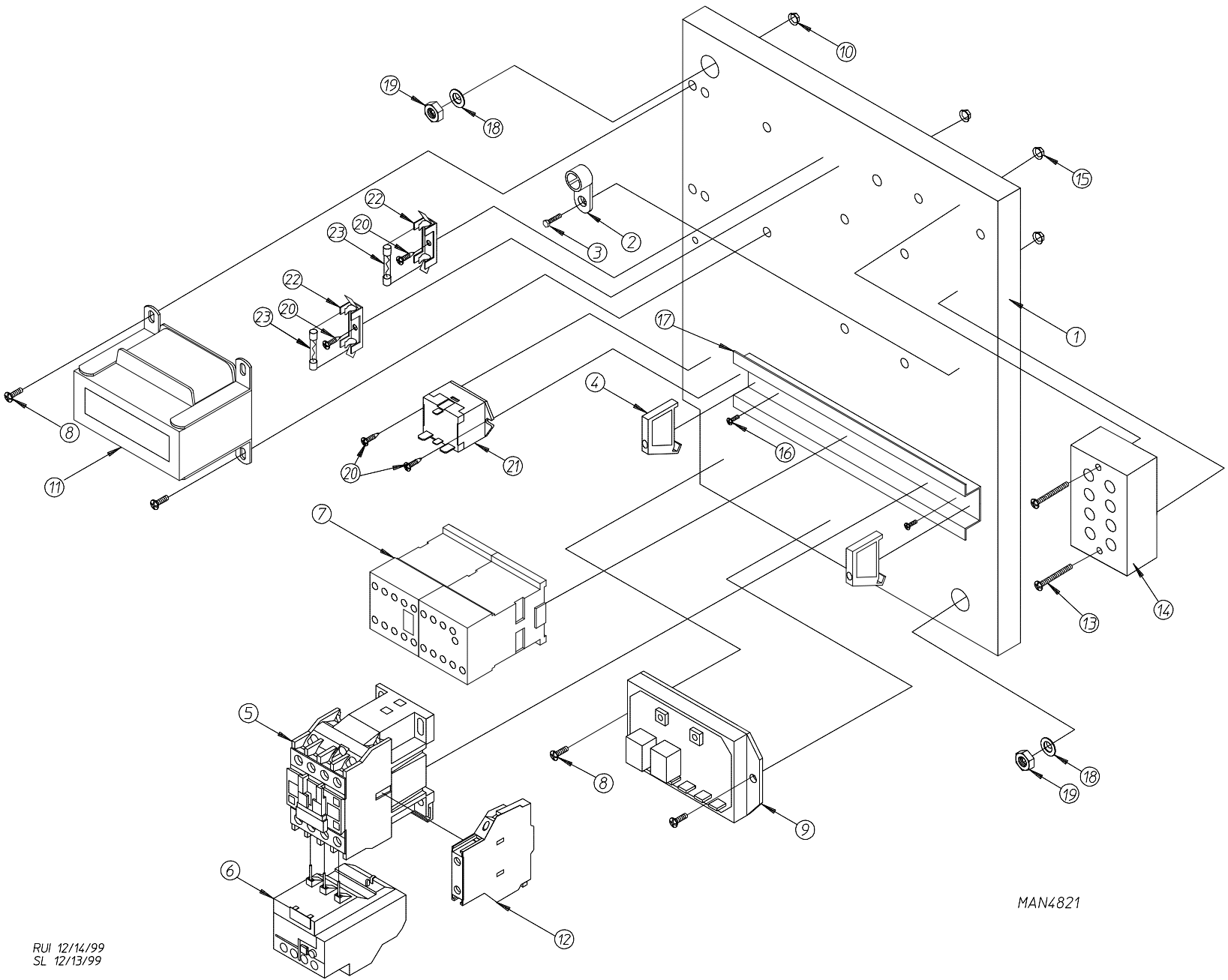

MAN4821

RUI 12/14/99
SL 12/13/99

<u>Illus. No.</u>	<u>Part No.</u>	<u>Qty.</u>	<u>Description</u>
1	332346	1	Contactor/Relay Mounting Panel ONLY
2	121010	1	L-70 Ground Lug
3	150297	1	#10 x 1/2" Hex Washer TEK Screw
4	120765	1	End Stop/Bracket
5	132465	1	3 HP Impellor (Blower/Fan) Contactor - 24 VAC
6	132467	1	Blower (Impellor/Fan) Overload (208 - 240 Volt)
7	132448	1	Reversing Contactor - 24 VAC
8	150108	2	#8-32 x 1/2" Pan Head Machine Screw
9	132198	1	Reversing Timer (50/60 Hz) - 24 VAC
10	151001	4	#8-32 Pal Nut
11*	835148	1	Phase 6 Transformer (208 - 240 Volt / 3 ϕ)
12	132383	1	2 N.O. (Normally Open) Auxiliary Contactor Block
13	150008	2	#6-32 x 1-1/4" Slotted Round Head Machine Screw
14	120701	1	4-Position Power Distribution Block
15	151000	2	#6-32 Pal Nut
16	150309	2	#10-16 x 1/2" Hex Head TEK Crimptite Screw
17	120768	9	Din Mounting Rail (sold by the inch)
18	153002	1	5/16" Lock Washer
19	152004	1	5/16-18 Hex Nut
20	150301	2	#8-18 x 7/16" Phillips Pan Head TEK Screw
21	131932	1	SPST (Single-Pole-Single-Throw) Panel Mount Relay - 24 VAC
22	136008	2	Fuse Block/Holder
23	136057	2	1/2-Amp (Slo-Blo) Fuse

* For 380 Volts or above, refer to the **Step Down Transformer Usage Listing** on page 44.

for Gas Models ONLY

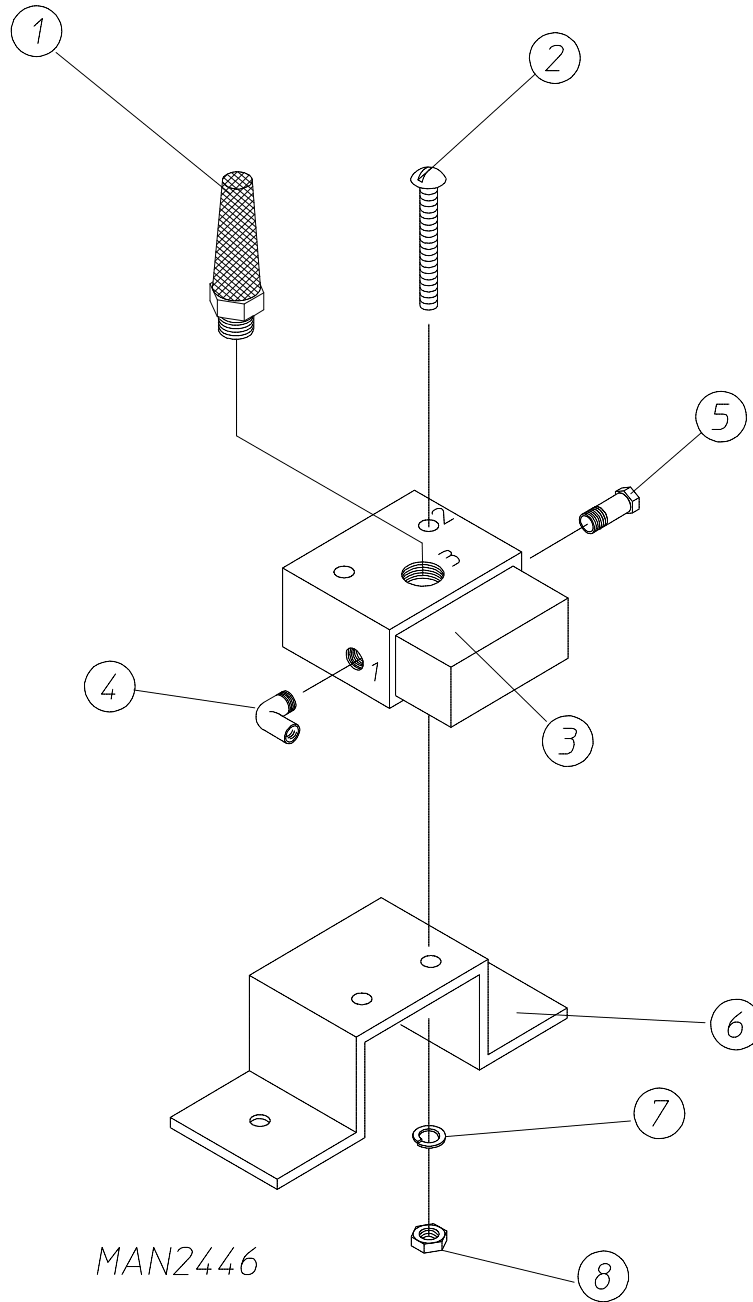

<u>Illus. No.</u>	<u>Part No.</u>	<u>Qty.</u>	<u>Description</u>
1	100520	1	1/8" N.P.T. Silencer (muffler) ONLY
2	150002	1	#6-32 x 1" Slotted Machine Screw
3	100498	1	3-Way Micro Valve ONLY - 24 VAC
	821105	1	Pneumatic Valve Assembly Complete (includes illus. nos. 1 through 8)
4	143268	1	1/8" Street Elbow
5	100472	1	1/4" x 1/8" Connector
6	330987	1	Micro Valve Support Bracket ONLY
7	153010	1	#6 Star Washer
8	152000	1	#6-32 Hex Nut

for Steam Models ONLY

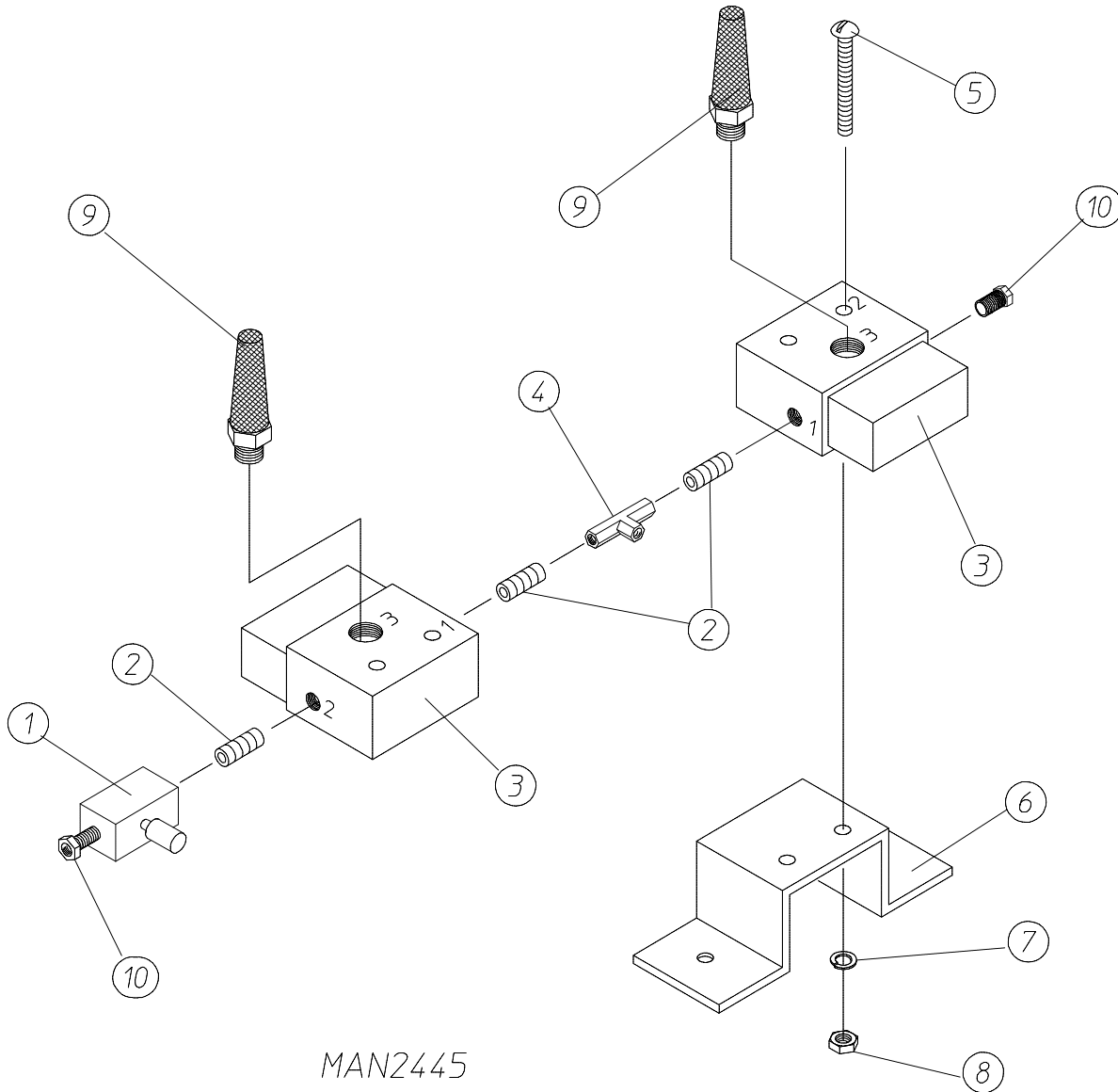

MAN2445

<u>Illus. No.</u>	<u>Part No.</u>	<u>Qty.</u>	<u>Description</u>
1	100496	1	1/8" Needle Valve
2	143238	3	1/8" Close Nipple
3	100498	2	3-Way Micro Valve ONLY - 24 VAC
	821104	1	Pneumatic Valve Assembly Complete (includes illus. nos. 1 through 8)
4	143223	1	1/8" F.P.T. Brass Tee
5	150002	2	#6-32 x 1" Slotted Machine Screw
6	330987	1	Micro Valve Support Bracket ONLY
7	153010	2	#6 Star Washer
8	152000	2	#6-32 Hex Nut
9	100520	2	1/8" N.P.T. Silencer (muffler) ONLY
10	100472	2	1/4" x 1/8" Connector

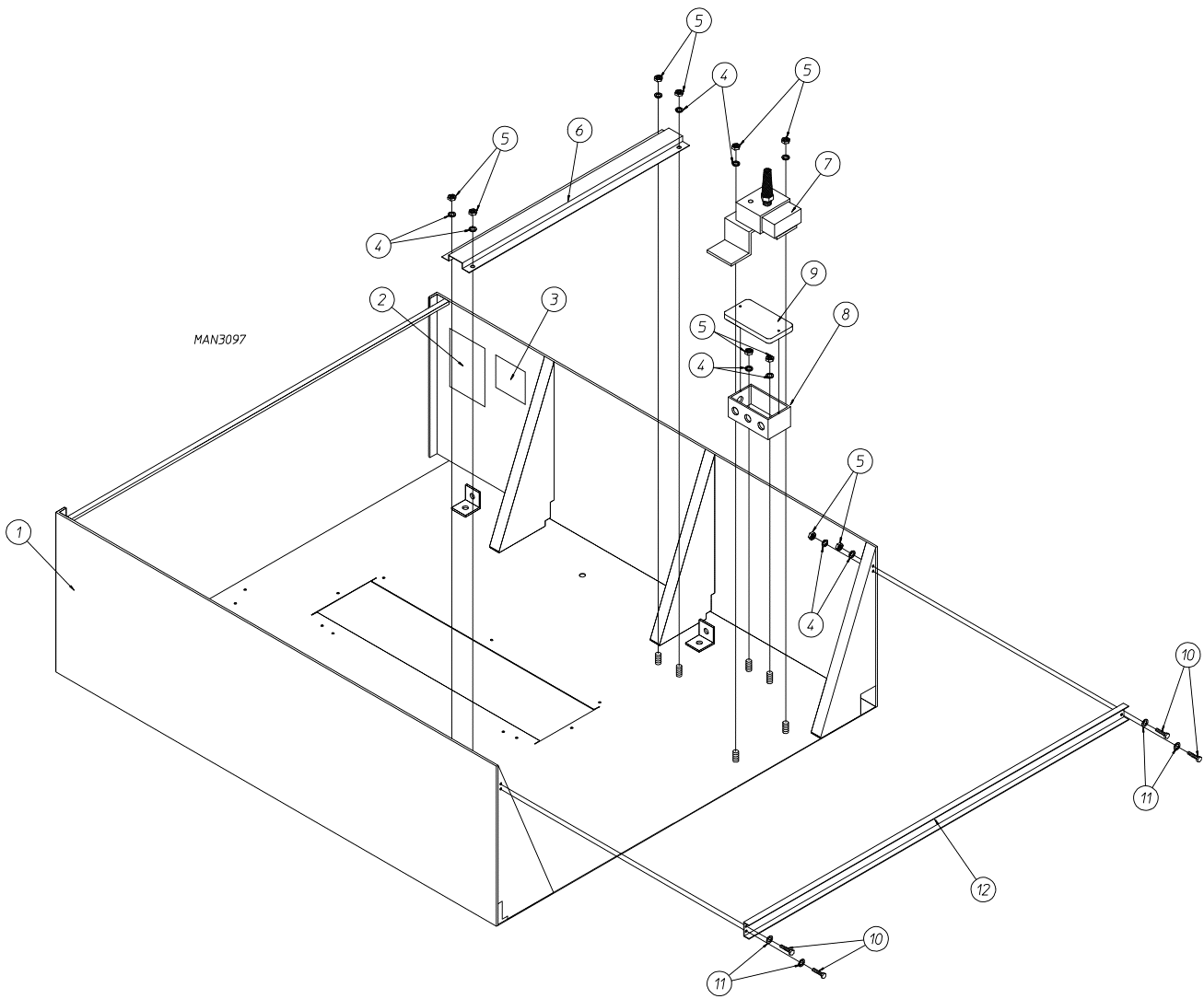

<u>Illus. No.</u>	<u>Part No.</u>	<u>Qty.</u>	<u>Description</u>
1	821085*	1	Top Console Assembly ONLY <i>(for Gas Models ONLY)</i>
	821086*	1	Top Console Assembly ONLY <i>(for Steam Models ONLY)</i>
2	112284	1	“Phase 6 OPL Program Location Summary” Label (for <i>Microprocessor Models ONLY</i>)
3	-----	1	Dryer Data Label (not for resale by ADC)
4	153007	12	1/4” Lock Washer
5	152002	12	1/4-20 Hex Nut
6	332323	1	32” Wire Channel
7	821105	1	Pneumatic Valve Assembly ONLY <i>(for Gas Models ONLY)</i> Refer to Pneumatic Valve Assembly on <u>page 38</u>
	821104	1	Pneumatic Valve Assembly ONLY <i>(for Steam Models ONLY)</i> Refer to Pneumatic Valve Assembly on <u>page 39</u>
8	121104	1	2” x 4” Junction Box ONLY
9	121105	1	Junction Box Cover ONLY
10	150615	1	1/4-20 x 3/4” Bolt
11	153018	4	1/4” Flat Washer
12	332186	1	Control Door Hinge Channel

* Specify color when ordering.

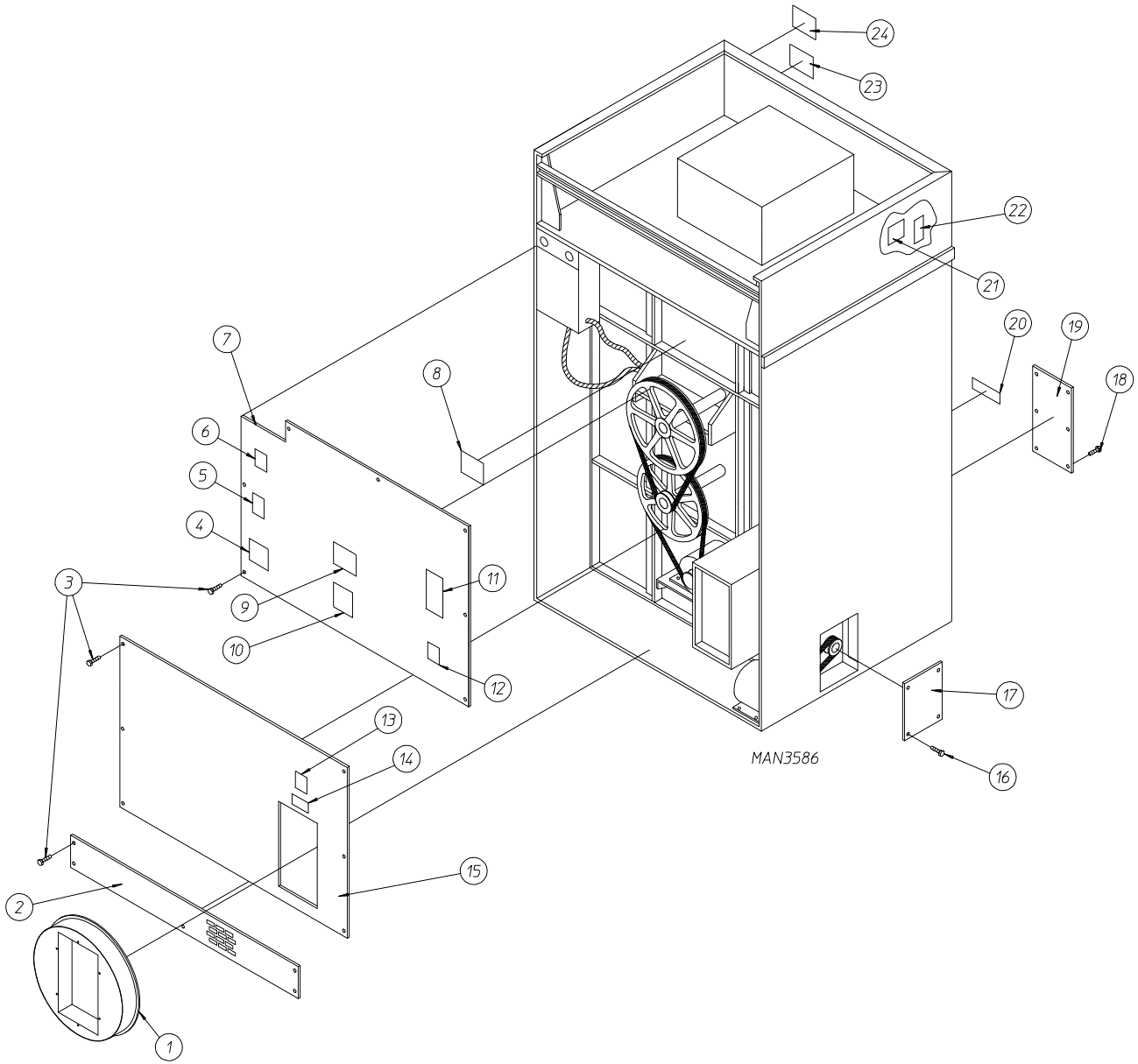

<u>Illus. No.</u>	<u>Part No.</u>	<u>Qty.</u>	<u>Description</u>
1	821092	1	Square Duct to 18" Round Duct Transition Piece Assembly (for Gas Models Only)
	821793	1	Square Duct to 20" Round Duct Transition Piece with Optional Damper (for Steam Models Only)
	821956	1	20" Exhaust Transition Piece Assembly (for Steam Models Only)
	821720	1	Square Duct to 18" Round Duct Transition Piece with Optional Damper (for Gas Models Only)
	117505	*	Aluminum Duct Tape (sold by the foot)
2	332328	1	Bottom Back Guard ONLY
3	150301	17	#8-18 x 7/16" Phillips Pan Head TEK Screw
4	112046	1	" IMPORTANT For Computer Ground" Label
5	112014	1	" HIGH VOLTAGE " Label
6	114007	1	" DANGER - High Voltage" Label
7	821095	1	Top Back Guard ONLY
8	112029	1	"Reversing Tumbler Drive" Label
9	112519	1	"Routine Maintenance Schedule" Label
10	114004	1	" CAUTION - Rotating Parts" Label
11	112230	1	"Installation Instructions" Label
12	112017	1	ADC Name, Address, Telephone Number Label
13	114008	1	" WARNING - Fumes" Label
14	114001	1	" CAUTION - Exhaust/Lint Screen" Label
15	821096	1	Middle Back Guard ONLY
16	150301	4	#8-18 x 7/16" Phillips Pan Head TEK Screw
17**	332309	1	Side Access Panel
18	150301	6	#8-18 x 7/16" Phillips Pan Head TEK Screw
19**	332295	1	Blower Housing Front Access Panel
20	112280	1	"Clean Lint Screen" Label
21	-----	1	Dryer Data Label <i>(not for resale by ADC)</i>
22	112284	1	"Phase 6 OPL Program Location Summary" Label (for Microprocessor Models ONLY)
23	114006	1	" WARNING - Fire Hazards" Label
24	114051	1	Phase 6 Computer "A and B Factor" Label

* As required.

** Specify color when ordering.

NOTE: FOR 380 VOLTS AND ABOVE

STEP DOWN TRANSFORMER APPLICATION LISTING (REVERSING RELAY)				
HEAT	VOLTAGE	WIRE SERVICE	TRANSFORMER PART NUMBER	
			MICROPROCESSOR MODELS	TIMER MODELS
GAS / STEAM	380	3 or 4	132059	132059
	416	3 or 4	132062	132062
	440	3 or 4	132056	132056
	460/480	3 or 4	132053	132053
	575	3	132050	132050

<u>Part No.</u>	<u>Description</u>
120102	3/8" Straight (BX) Connector
120111	1/2" Liquidtite 45° Connector
120400	3/8" Red Jacket (BX) Insulator
120500	3/8" Jiffy Clip (BX Retainer Clip)
120600	3/8" Greenfield (BX)
120800	1/4" In-Line Connector
120802	Red Butt Connector
120902	#74B Wire Nut
120903	Crimp-on Wire Nut
120904	Red Wire Nut
121014	1/4" Insulated (female) Terminal
121499	5-1/2" Harness Tie
121500	7" Harness Tie
122804	Manometer (water column test gauge)
404500	Almond Brush-In-Cap Bottle Touch-Up Paint
404502	White Brush-In-Cap Bottle Touch-Up Paint
404506	Beige Brush-In-Cap Bottle Touch-Up Paint
404507	Cornflower Blue Brush-In-Cap Bottle Touch-Up Paint
880200	Electrical Terminal (assortment) Kit

ADC450176

1 - 01/29/98-50
4 * 12/18/02-25

2 * 01/18/00-50

3 - 06/05/00-25

