

# **ML-202**

# **Parts Manual**

## **Phase 7**

---

**American Dryer Corporation**  
88 Currant Road  
Fall River MA 02720-4781 USA  
Telephone: +1 (508) 678-9000 / Fax: +1 (508) 678-9447  
e-mail: [techsupport@amdry.com](mailto:techsupport@amdry.com)

[www.adclaundry.com](http://www.adclaundry.com)

# Retain This Manual In A Safe Place For Future Reference

American Dryer Corporation products embody advanced concepts in engineering, design, and safety. If this product is properly maintained, it will provide many years of safe, efficient, and trouble free operation.

**ONLY qualified technicians should service this equipment.**

**OBSERVE ALL SAFETY PRECAUTIONS** displayed on the equipment or specified in the installation manual included with the dryer.

The following “**FOR YOUR SAFETY**” caution must be posted near the dryer in a prominent location.

## FOR YOUR SAFETY

Do not store or use gasoline or other flammable vapors and liquids in the vicinity of this or any other appliance.

## POUR VOTRE SÉCURITÉ

Ne pas entreposer ni utiliser d'essence ni d'autres vapeurs ou liquides inflammables à proximité de cet appareil ou de tout autre appareil.

We have tried to make this manual as complete as possible and hope you will find it useful. ADC reserves the right to make changes from time to time, without notice or obligation, in prices, specifications, colors, and material, and to change or discontinue models.

## Important

For your convenience, log the following information:

DATE OF PURCHASE \_\_\_\_\_ MODEL NO. **ML-202**  
RESELLER'S NAME \_\_\_\_\_  
Serial Number(s) \_\_\_\_\_  
\_\_\_\_\_  
\_\_\_\_\_

Replacement parts can be obtained from your reseller or the ADC factory. When ordering replacement parts from the factory, you can FAX your order to ADC at (508) 678-9447 or telephone your order directly to the ADC Parts Department at (508) 678-9000. Please specify the dryer model number and serial number in addition to the description and part number, so that your order is processed accurately and promptly.

The illustrations on the following pages may not depict your particular dryer exactly. The illustrations are a composite of the various dryer models. Be sure to check the descriptions of the parts thoroughly before ordering.

### **“IMPORTANT NOTE TO PURCHASER”**

Information must be obtained from your local gas supplier on the instructions to be followed if the user smells gas. These instructions must be posted in a prominent location near the dryer.

# Table of Contents

Control Door Assembly .....	4
Phase 7 Non-Coin Microprocessor Control Panel Assembly .....	5
Main Door .....	6
Main Door Pulleys and Cables .....	7
Front Panel .....	8
Tumbler Assembly .....	9
Lint Door Assembly .....	10
Lint Drawer / Lint Drawer Switch Box Assemblies .....	11
Lint Switch Assembly .....	12
Rotational Sensor Assembly .....	13
Idler Shaft Assembly .....	14
Drive Shaft Assembly .....	15
Speed Reducer Shaft Assembly .....	16
Microprocessor Temperature Sensor Bracket Assembly .....	17
Totally Enclosed, Non-Venting Drive Motor Assembly .....	18
Blower Motor Mount Assembly .....	19
Fan (Squirrel Cage) Shaft Mount Assembly .....	20
Direct Spark Ignition Burner Assembly .....	22
Sail Switch Assembly .....	24
Steam Damper Assembly .....	25
Top Console Assembly .....	26
Pneumatic Valve Assembly for Gas Models Only .....	27
Pneumatic Valve Assembly for Steam Models Only .....	28
Air Jet Assembly .....	29
Reversing Relay Panel Assembly for 208-240 Volts .....	30
Reversing Relay Panel Assembly for 460-480 Volts .....	32
Fire Suppression System Temperature Probe Assembly .....	34
Fire Suppression System Solenoid Assembly .....	35
Back Guard Assemblies .....	36

# Control Door Assembly

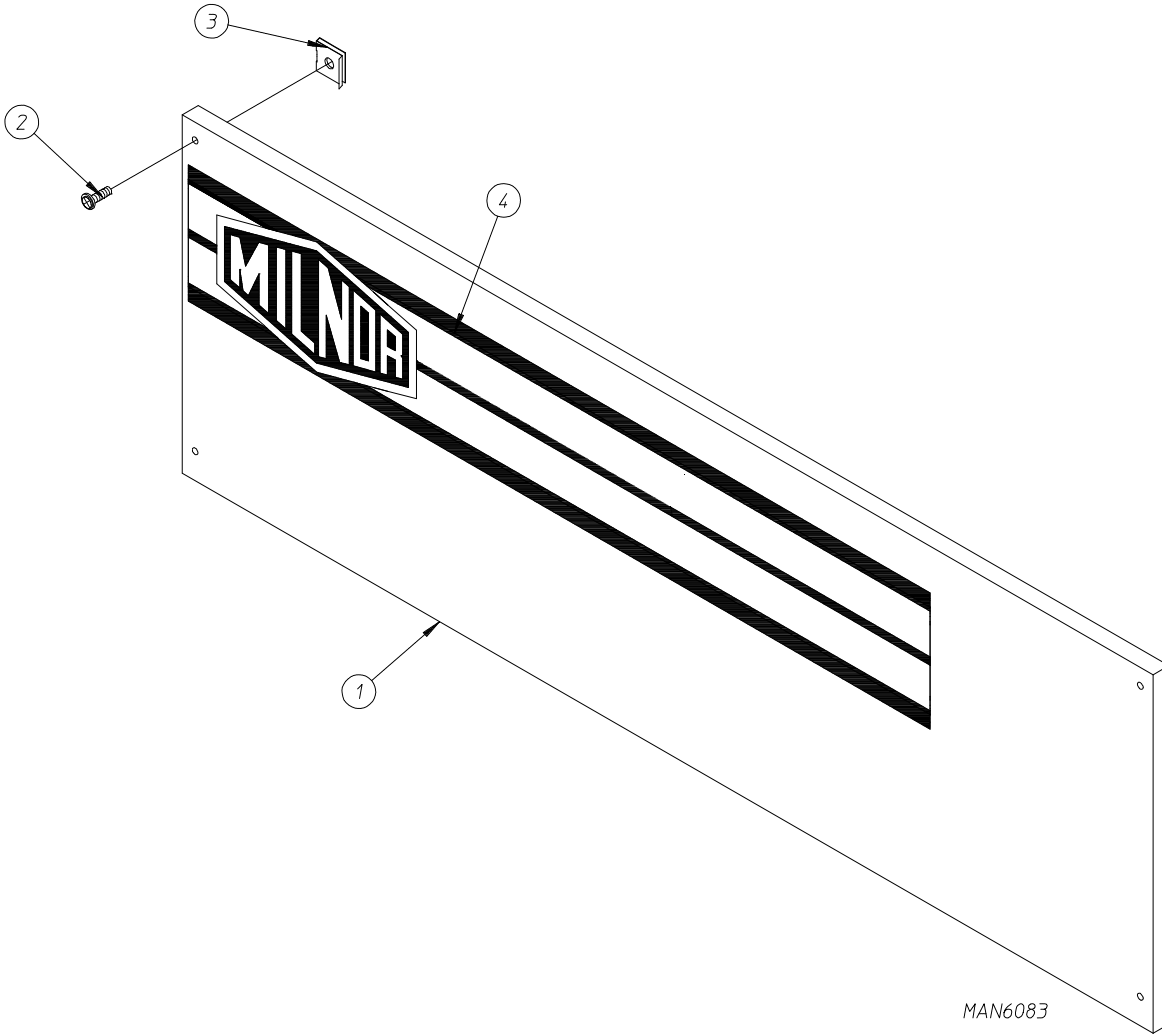

MAN6083

BYORK 2/14/02

<u>Illus. No.</u>	<u>Part No.</u>	<u>Qty.</u>	<u>Description</u>
1*	882364	1	Phase 7 Control Door
2	150321	4	#10-32 x 1/2" Phillips Machine Screw
3	154011	4	#10-32 Multi-Thread U-Nut
4	112372	1	Milnor Logo

\* Specify color when ordering.

# Phase 7 Non-Coin Microprocessor Control Panel Assembly

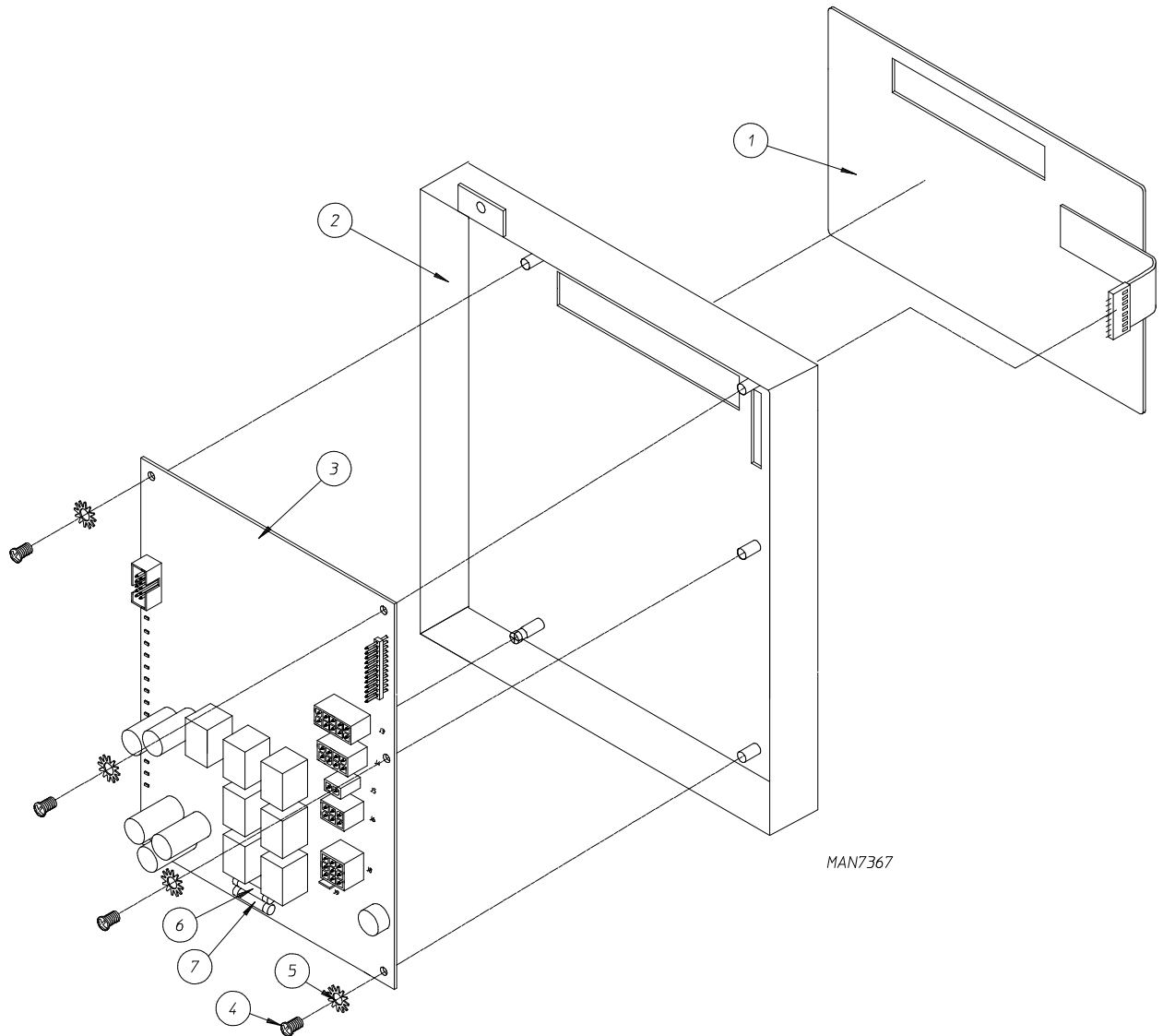

<u>Illus. No.</u>	<u>Part No.</u>	<u>Qty.</u>	<u>Description</u>
1	112577	1	Phase 7 Non-Coin Keypad
2	828533	1	Phase 7 Microprocessor Computer Panel
3	887003	1	Phase 7 Microprocessor Computer with F.S.S.
	887024	1	Phase 7 Microprocessor Computer for Models Mfd. without F.S.S.
4	150005	4	#6-32 x 3/4" Phillips Round Head Machine Screw
5	153010	4	#6 Star Washer
6	136016	1	5-Amp Fuse

# Main Door

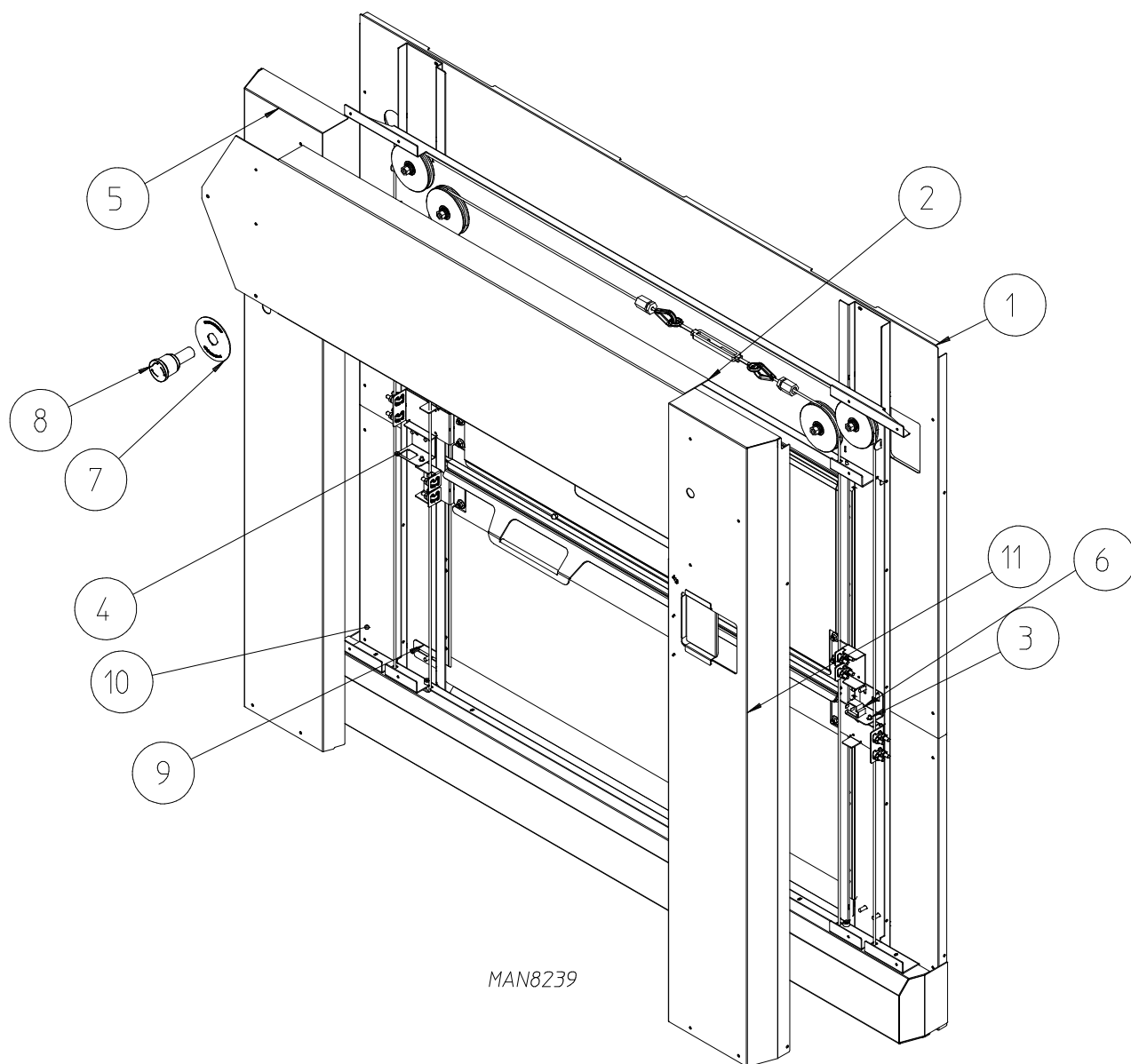

<u>Illus. No.</u>	<u>Part No.</u>	<u>Qty.</u>	<u>Description</u>
1	828519	1	Vertical Door Insulated Front Panel Assembly <b>(refer to page 8 for additional information)</b>
2	328732	1	Vertical Door Top Cable Cover
3	828524	1	Switch Magnet Bracket Assembly
4	828525	1	Magnet Bracket Assembly (includes illus. nos. 4 and 6)
5	328731	1	Vertical Door Left-Hand Cable Cover
6	122002	1	Door Switch
7	112599	1	Emergency Stop Label
8	123583	1	E-Stop 1 NO 1 NC
9	328747	*	Vertical Door Frame Spacer
10	828538	1	Vertical Door Bumper
11	828528	1	Vertical Door Right-Hand Cable Cover

\* As needed.

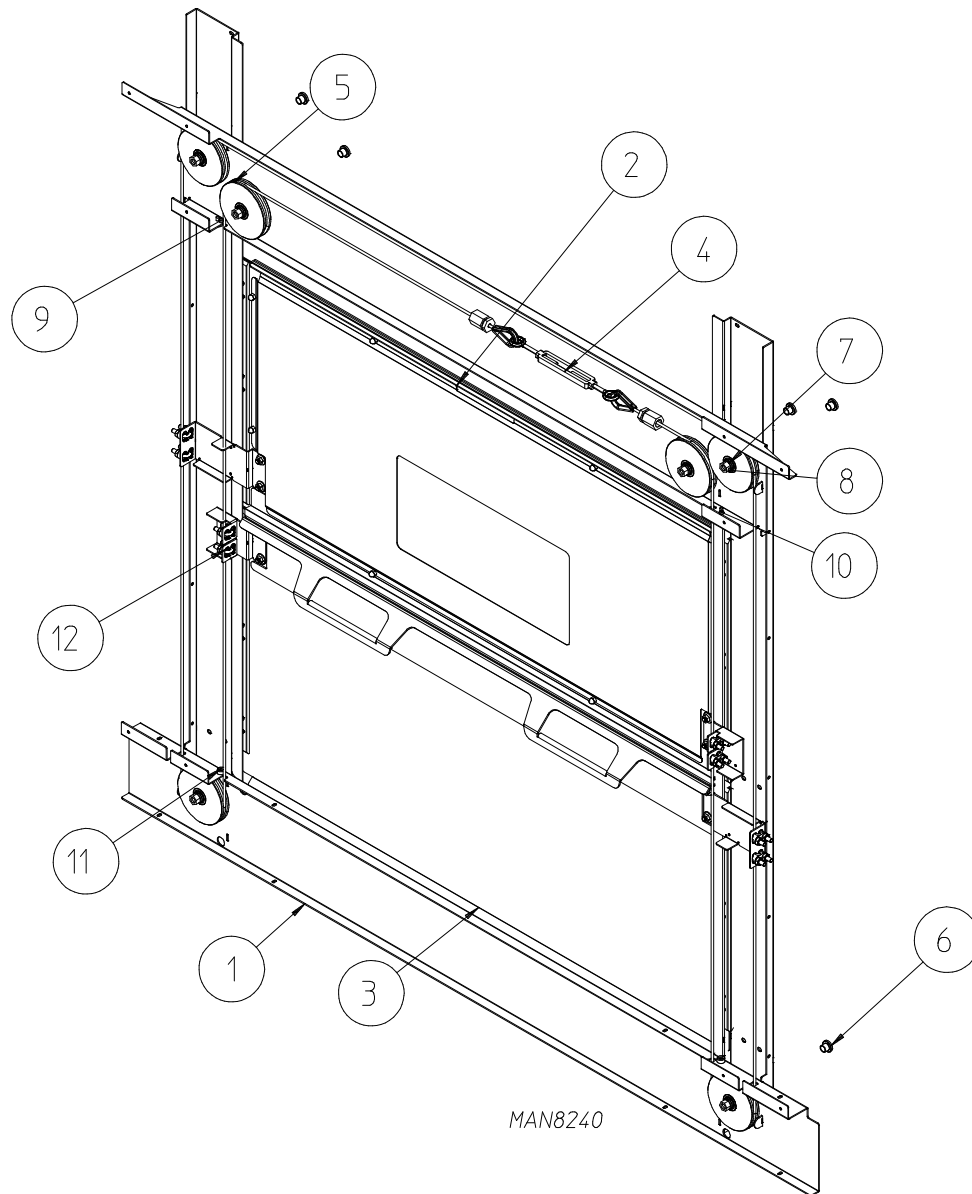

<u>Illus. No.</u>	<u>Part No.</u>	<u>Qty.</u>	<u>Description</u>
1	828527	1	Door Assembly (includes illus. nos. 1 through 12)
	828522	1	Vertical Door Frame
2	828513	1	Upper Door Assembly
3	828511	1	Lower Door Assembly
4	828526	1	Vertical Door Cable Assembly
5	101190	6	4" x 5/8" x 1/2" Cable Pulley
6	328718	12	Vertical Door Cable Pulley Spacer
7	152005	6	3/8-16 Hex Nut
8	153005	6	3/8" Lock Washer
9	102004	2	Magnet
10	152223	2	#10-32 x 1/2" TORX® Screw
11	102369	2	Rubber Bumper
12	125719	8	1/8" Cable Clamp

# Front Panel

---

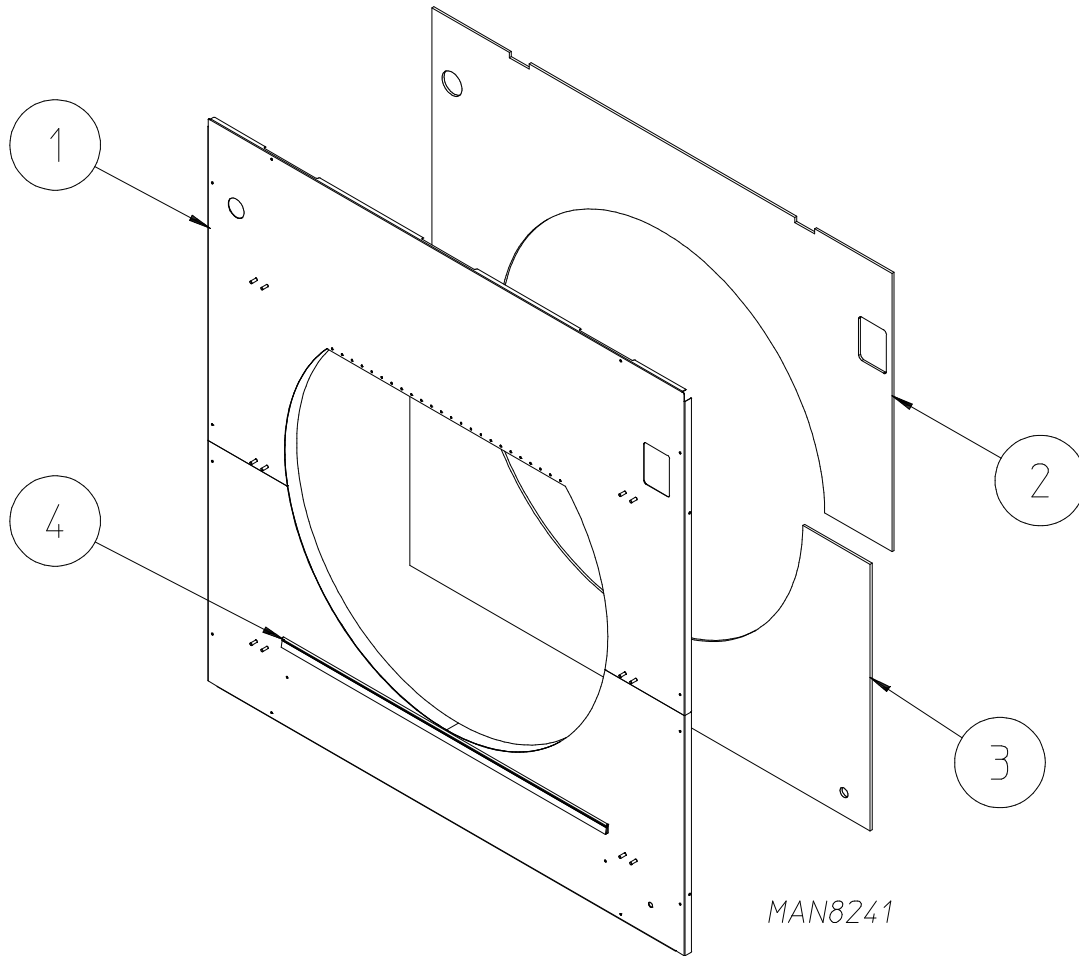

---

<u>Illus. No.</u>	<u>Part No.</u>	<u>Qty.</u>	<u>Description</u>
1	828518	1	Vertical Door Front Panel
2	115937	1	Vertical Door Upper Front Panel Insulation
3	115936	1	Vertical Door Lower Front Panel Insulation
4	115935	1	Main Door Felt

---



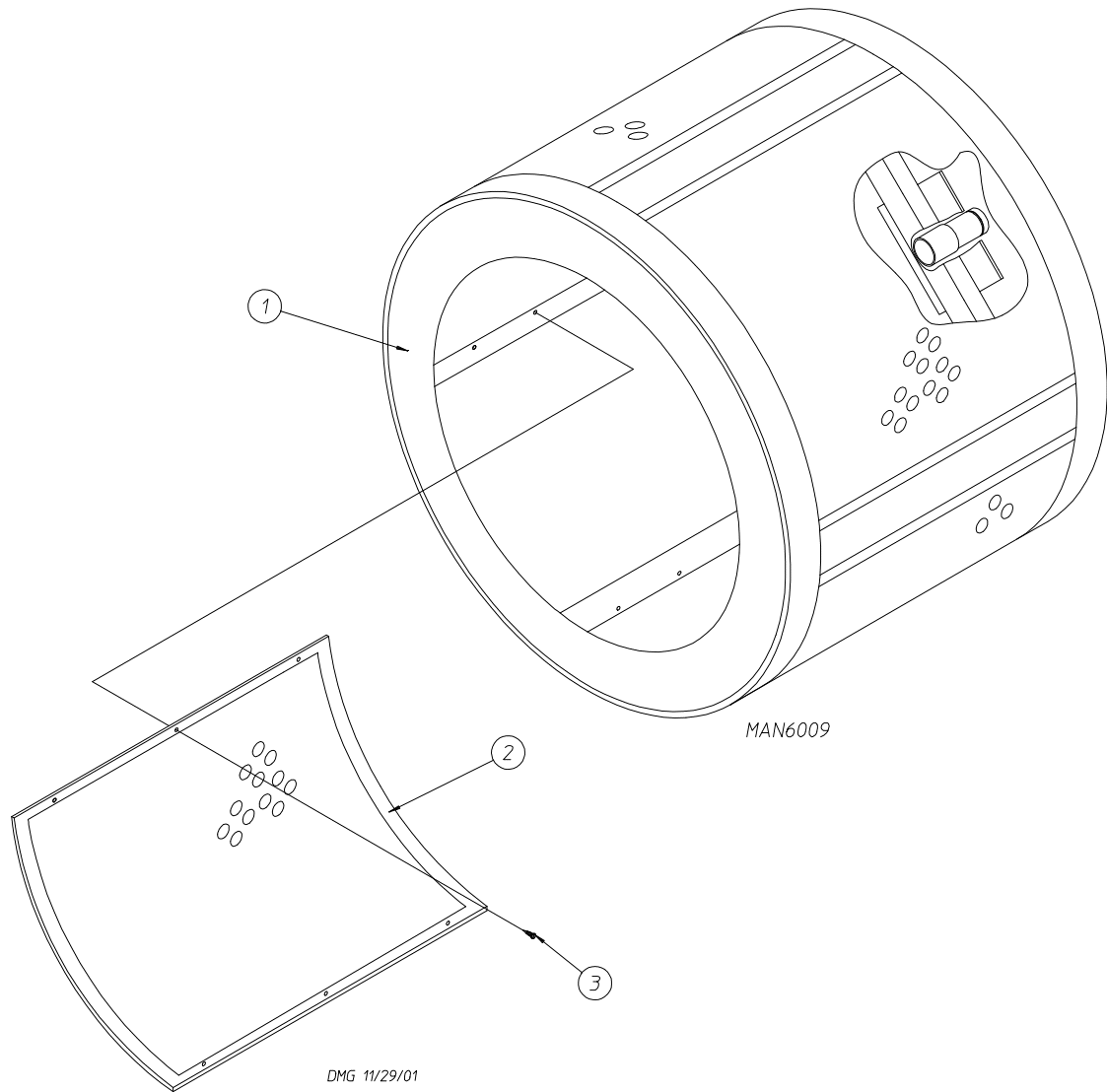

<u>Illus. No.</u>	<u>Part No.</u>	<u>Qty.</u>	<u>Description</u>
1	828515	1	Stainless Steel Tumbler Assembly
2	333667	4	Perforated Stainless Steel Tumbler Panel
3	150118	40	1/4-20 x 1/4" Phillips Pan Head Screw
	881619	1	Rotational Sensor Magnet ... Not Illustrated

# Lint Door Assembly

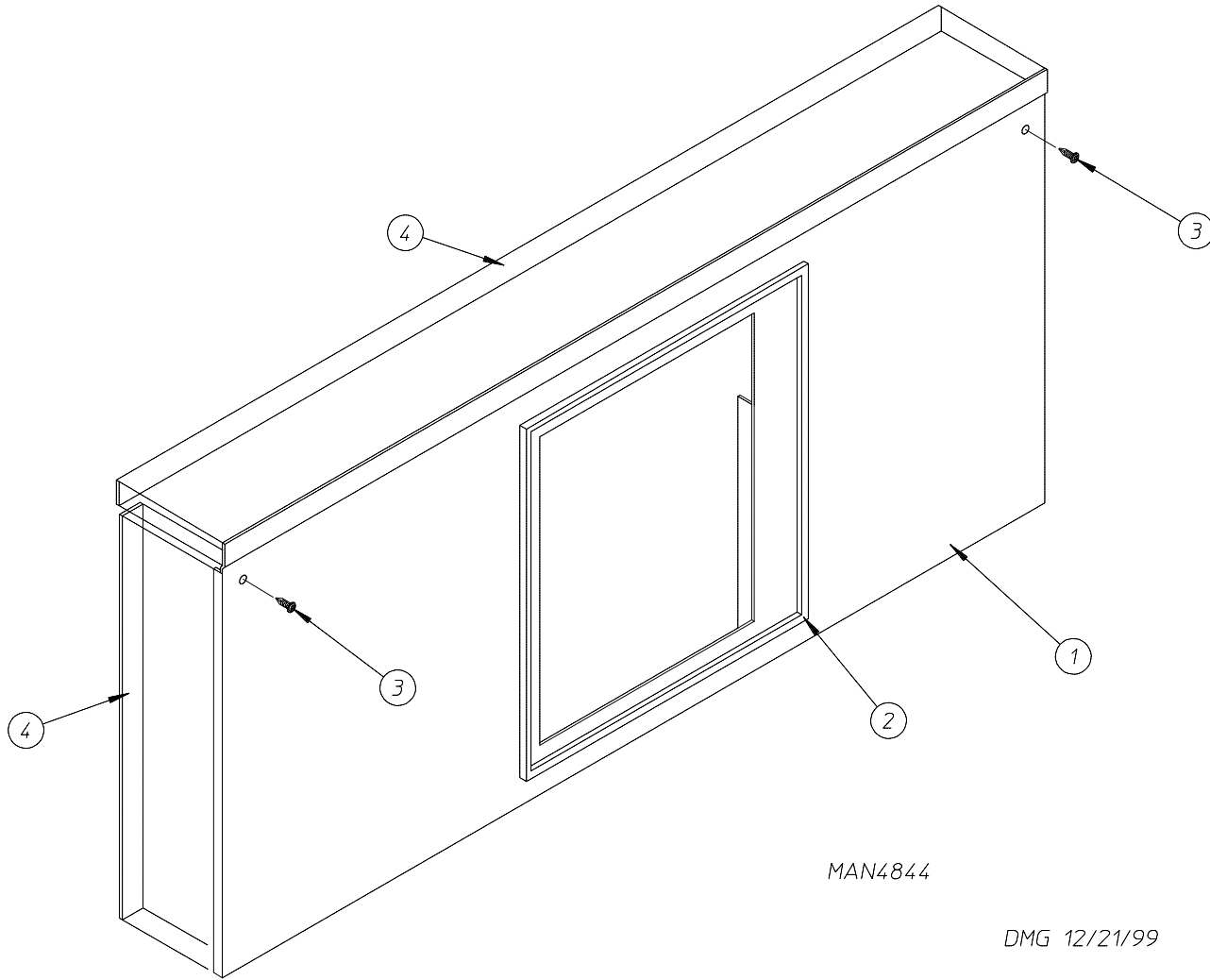

MAN4844

DMG 12/21/99

<u>Illus. No.</u>	<u>Part No.</u>	<u>Qty.</u>	<u>Description</u>
1	828502*	1	Lint Door Assembly (includes illus. nos. 1 through 4)
2	117617	6'	Neoprene Sponge Tape (sold by the foot)
3	150313	5	#10-16 x 1/2" TORX® Screw
4	117617	10'	Neoprene Sponge Tape (sold by the foot)

\* Specify color.

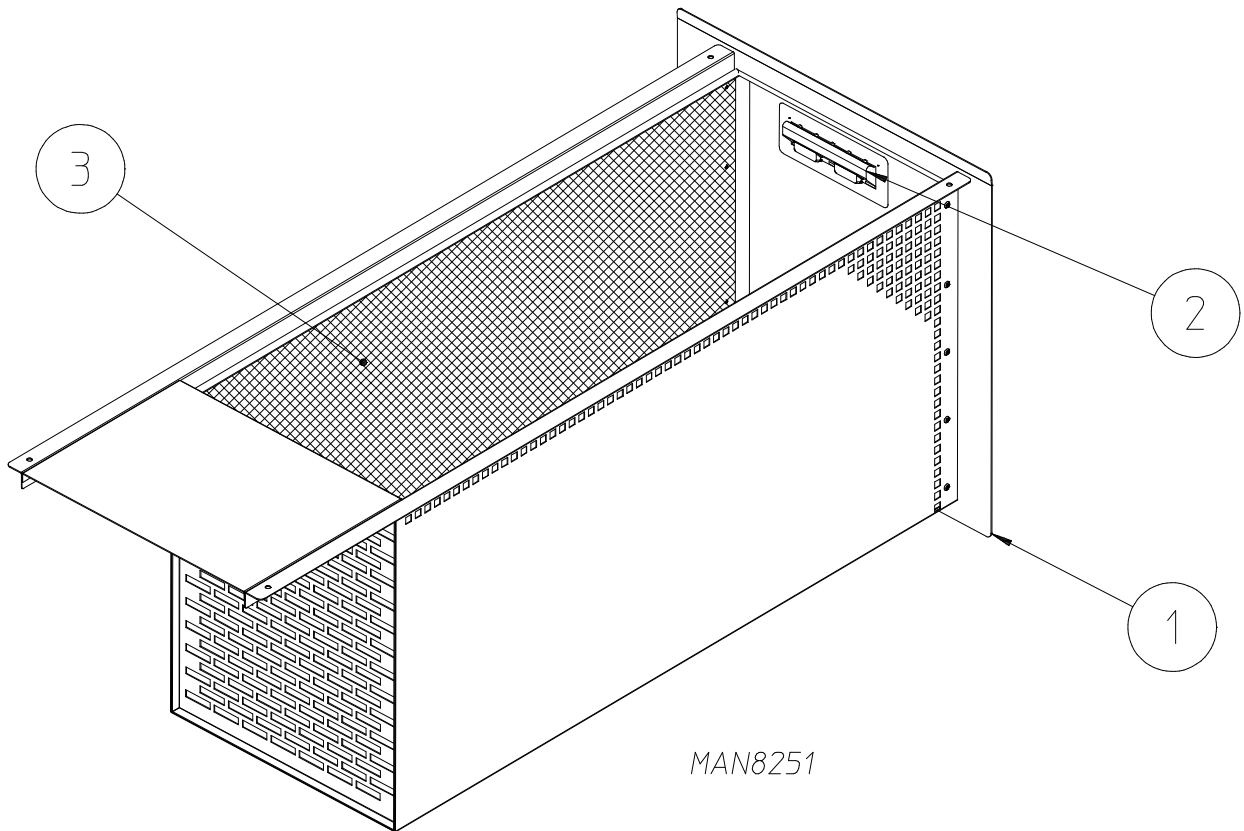

<u>Illus. No.</u>	<u>Part No.</u>	<u>Qty.</u>	<u>Description</u>
1	828532*	1	Lint Drawer Assembly (includes illus. nos. 1 through 3)
2	170224	1	Lint Drawer Handle
3	108220	1	Lint Screen Assembly

\* Specify color when ordering.

# Lint Switch Assembly

---

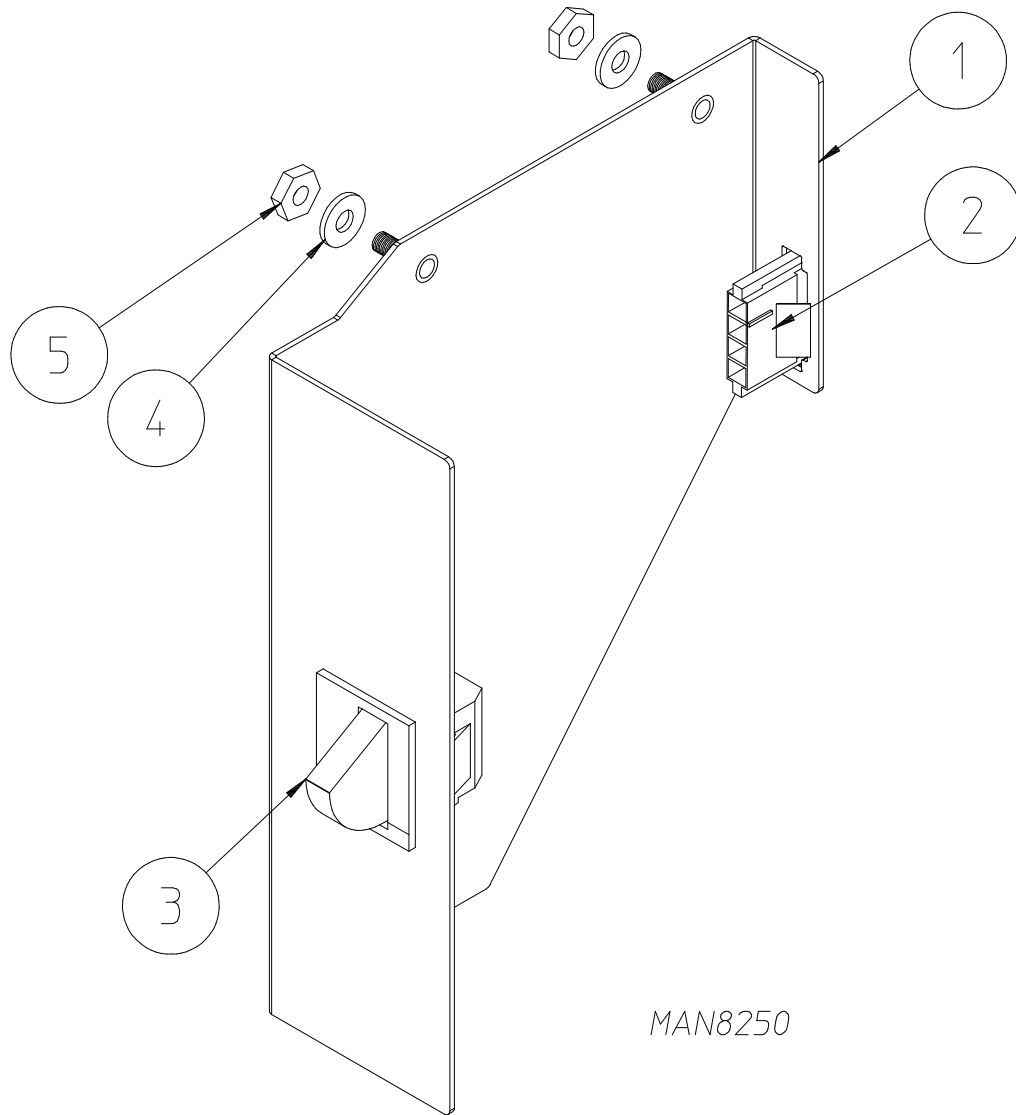

---

<u>Illus. No.</u>	<u>Part No.</u>	<u>Qty.</u>	<u>Description</u>
1	828537	1	Lint Switch Assembly (includes illus. nos. 1 through 5)
	828536	1	Lint Switch Bracket Only
2	828498	1	Lint Door Switch Harness
3	122002	1	Lint Door Switch
4	153000	2	#8 Flat Washer
5	152001	2	#8-32 Hex Nut

---

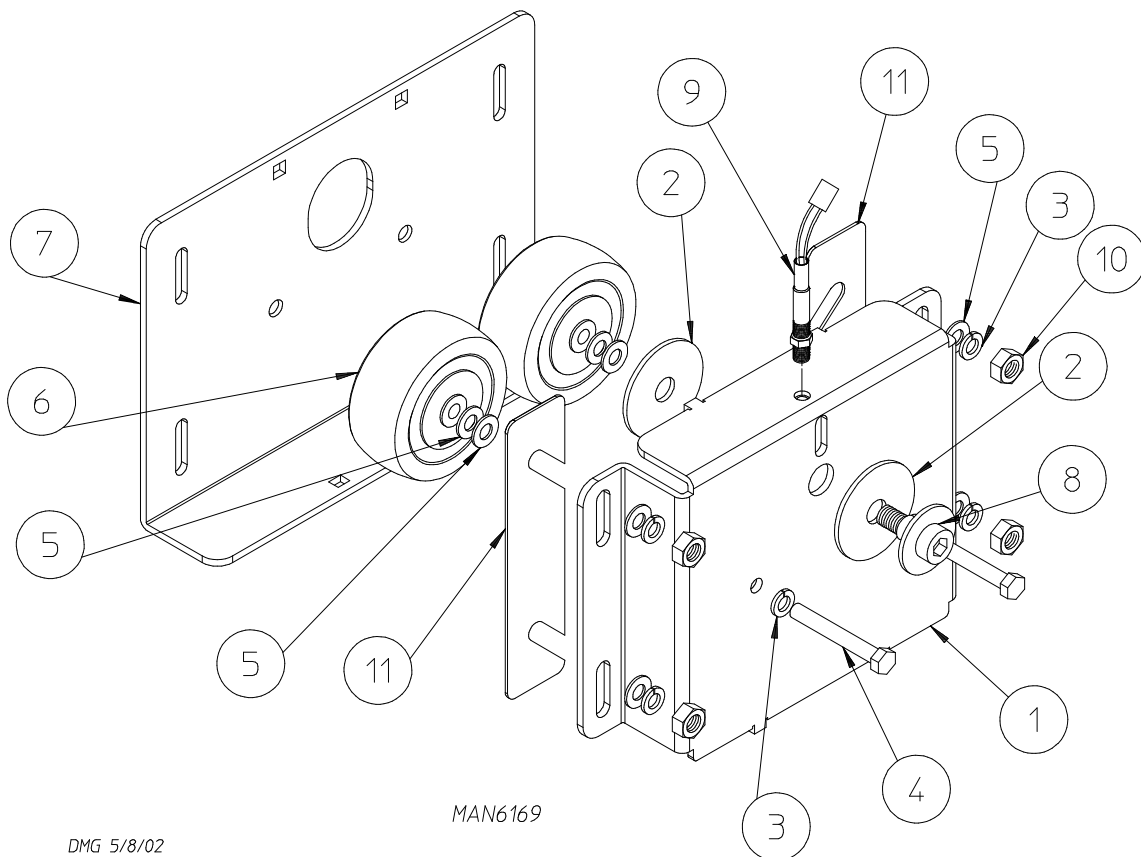

MAN6169

DMG 5/8/02

<u>Illus. No.</u>	<u>Part No.</u>	<u>Qty.</u>	<u>Description</u>
1	815495	1	Tumbler Shaft Support Assembly Complete (includes illus. nos. 1 through 8 and 11)
	315826	1	Tumbler Shaft Support Bracket Only
2	102394	2	Tumbler Friction Pad
3	153005	6	3/8" Lock Washer
4	150634	2	3/8-16 x 1" Tap Bolt
5	153004	8	3/8" Flat Washer
6	180018	2	4" x 1-1/2" Hi-Impact Wheel
	315816	2	Wheel Spacer ... Not Illustrated
7	815494	1	Tumbler Adjustment Plate
8	819065	1	Tumbler Shoulder Screw
9	822735	1	Phase 7 Rotational Sensor Assembly
10	152005	4	3/8-16 Hex Nut
11	323433	2	Rear Wheel Shim

# Idler Shaft Assembly

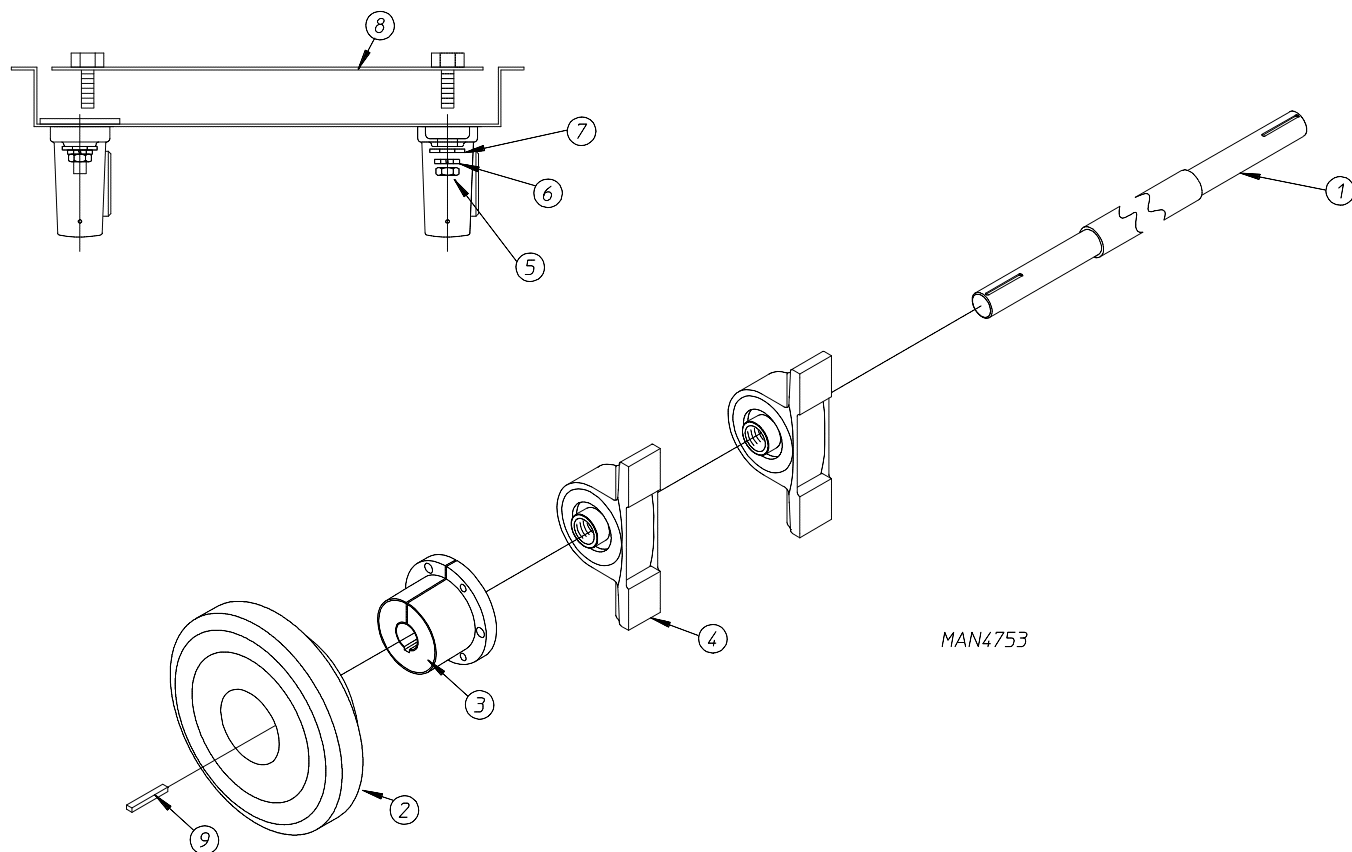

MAN4753

<u>Illus. No.</u>	<u>Part No.</u>	<u>Qty.</u>	<u>Description</u>
1	319062	1	Idler Shaft
2	821465	1	11" Drive Wheel
3	101227	1	1-1/2" Taper Lock Bushing
4	880880	2	1-1/2" Pillow Block Bearing
5	152011	4	1/2-13 Hex Nut
	152002	4	3/8-18 Hex Nut
6	153026	4	1/2" Lock Washer
7	153050	4	1/2" Flat Washer
8	819015	1	Bearing Backing Plate Assembly
9	100710	1	3/8" x 3/8" x 3" Key

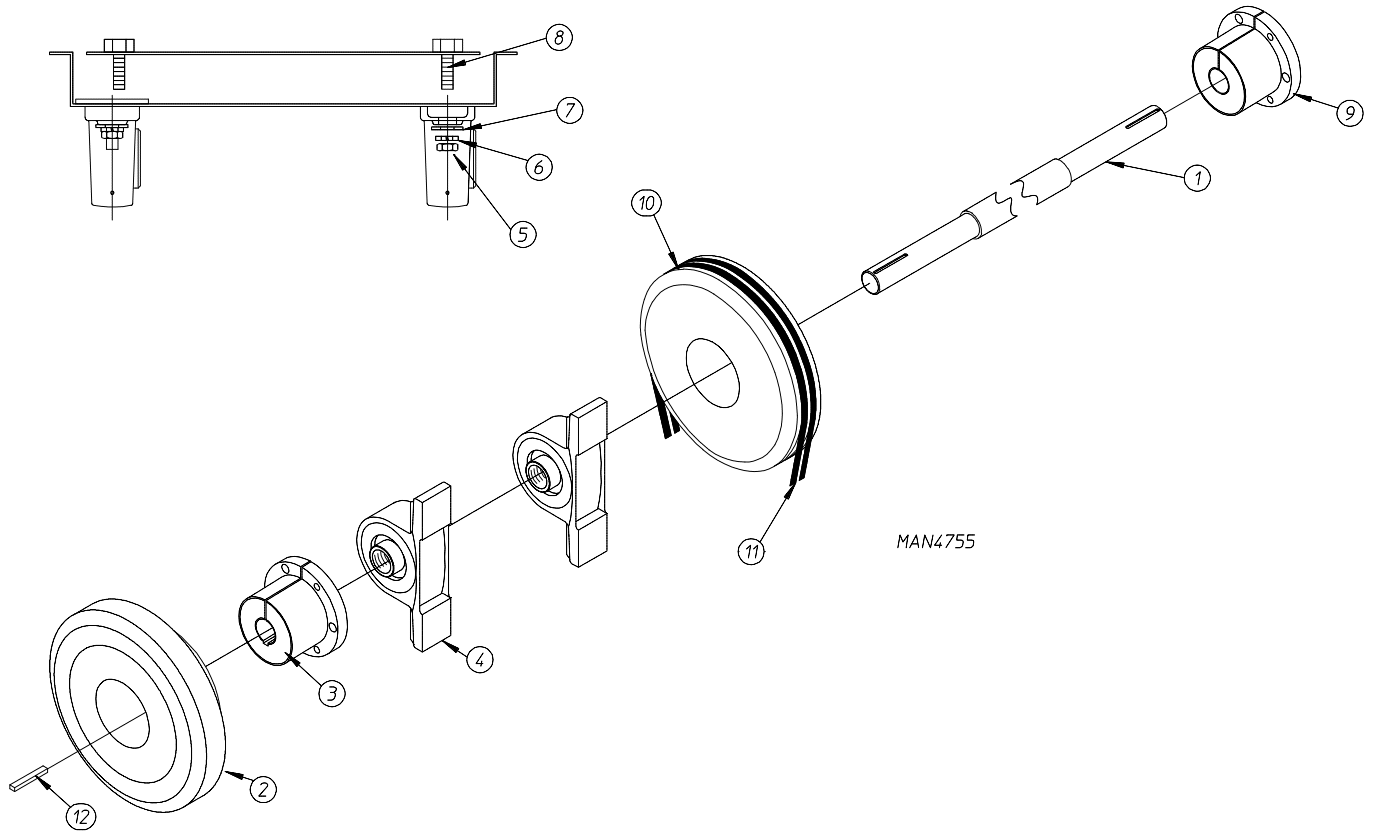

<u>Illus. No.</u>	<u>Part No.</u>	<u>Qty.</u>	<u>Description</u>
1	319062	1	Drive Shaft
2	821465	1	11" Drive Wheel
3	101227	1	1-1/2" Taper Lock Bushing
4	880880	2	1-1/2" Pillow Block Bearing
5	152011	4	1/2-13 Hex Nut
6	153026	4	1/2" Lock Washer
7	153050	4	1/2" Flat Washer
8	819015	1	Bearing Backing Plate Assembly
9	101150	1	1-1/2" Bushing with Setscrew
10	101189	1	2B x 8.0 Pulley
11*	100149	2	BX-44 Cogged Belt
12	100717	1	5/16" x 5/16" x 2-3/4" Key

\* Replace in matched sets (both belts).

# Speed Reducer Shaft Assembly

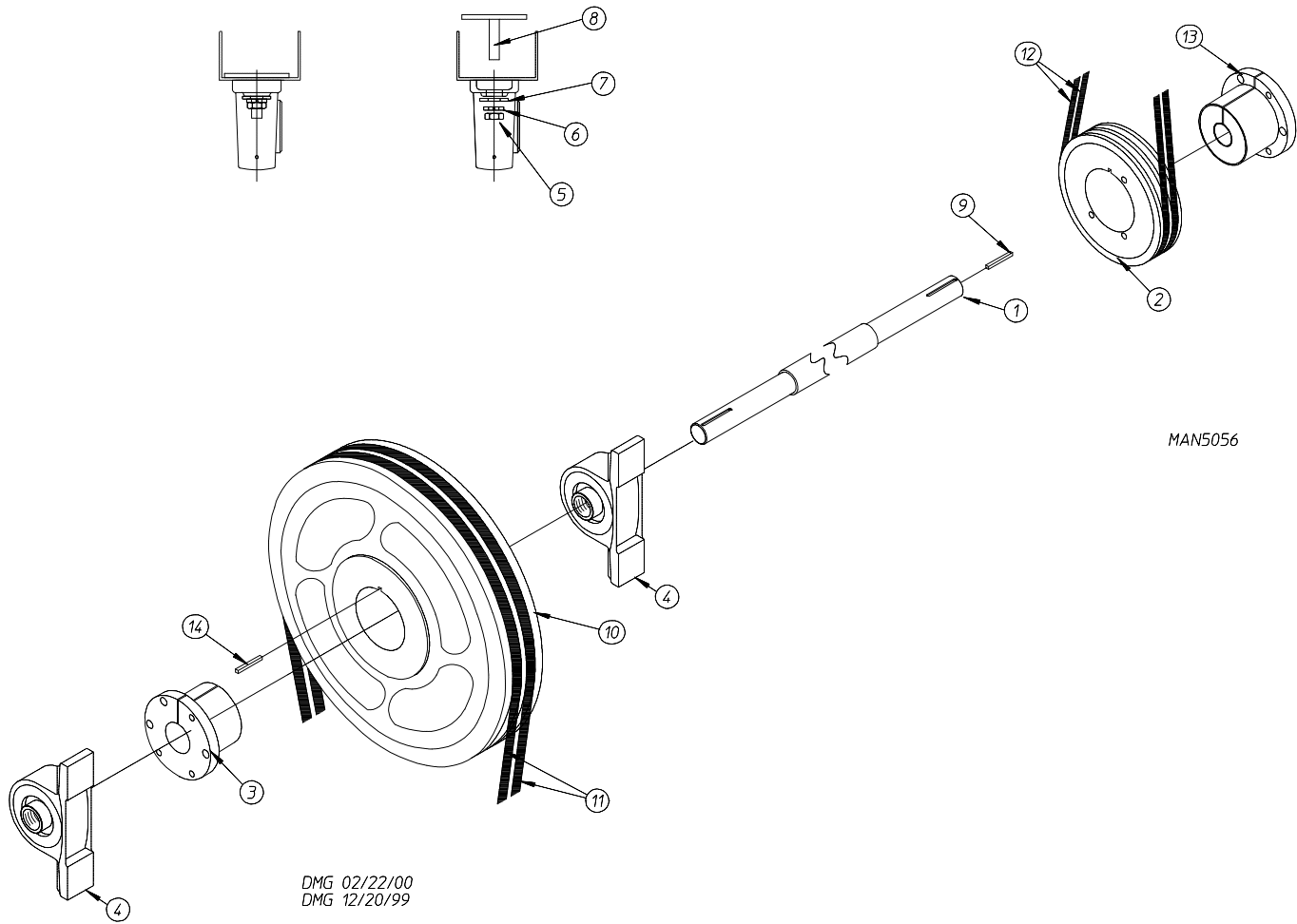

<u>Illus. No.</u>	<u>Part No.</u>	<u>Qty.</u>	<u>Description</u>
1	319062	1	Speed Reducing Shaft
2	101160	1	2B x 3.4 SH Sheave
3	101150	1	1-1/2" Bushing with Setscrew
4	880880	2	1-1/2" Pillow Block Bearing
5	152011	4	1/2-13 Hex Nut
6	153026	4	1/2" Lock Washer
7	153050	4	1/2" Flat Washer
8	819015	1	Bearing Back Up Plate
9	—	1	Bushing Key (includes illus. no. 13)
10	101193	1	2B x 13.6" SK Sheave
11*	100164	2	BX-51 Belt
12*	100149	2	BX-44 Cogged Belt
13	101230	1	SH x 1-1/2" Bushing with Setscrew (includes illus. no. 9)
14	100710	1	3/8" x 3/8" x 3" Key

\* Replace in matched sets (both belts).



# Microprocessor Temperature Sensor Bracket Assembly

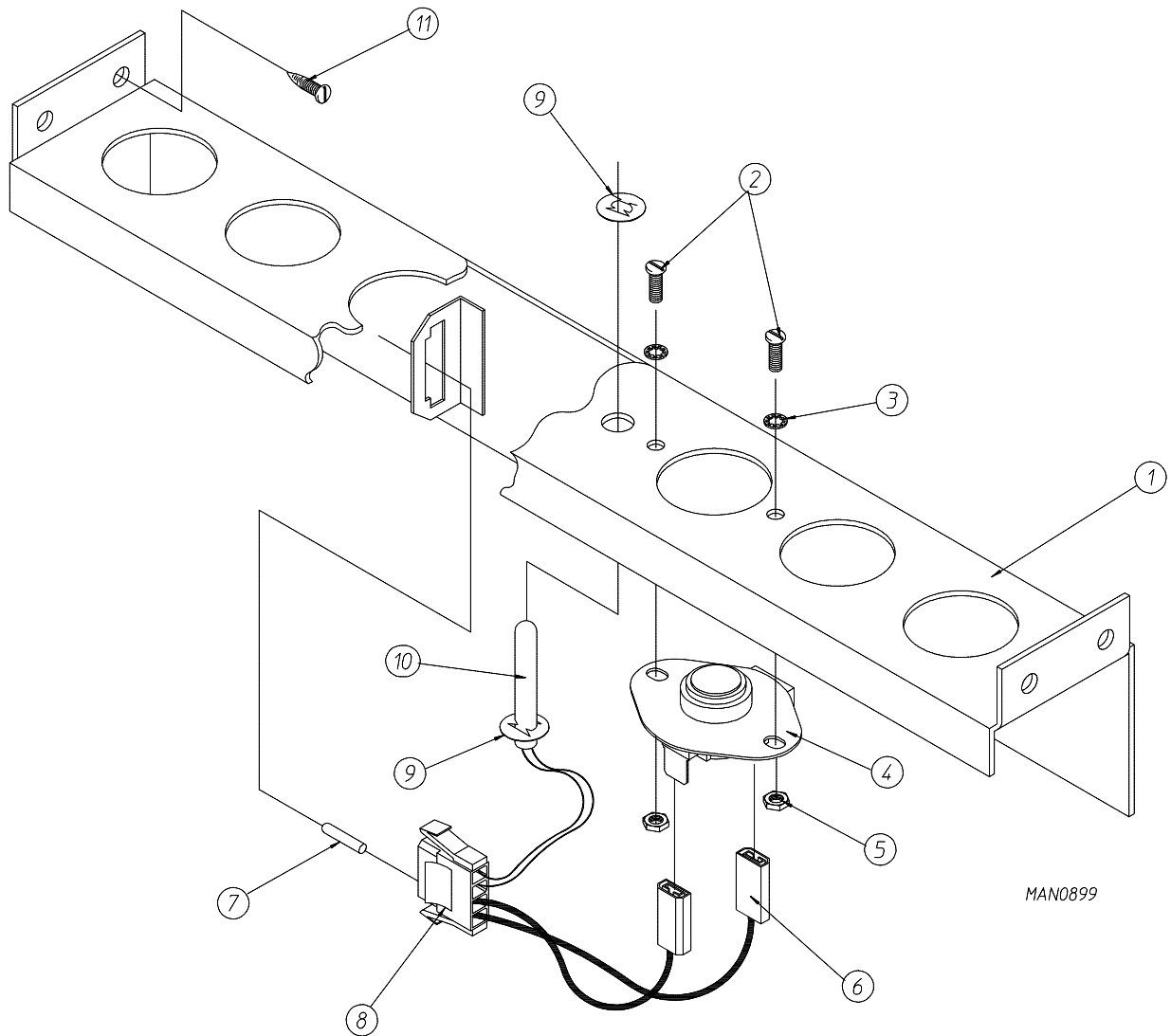

<u>Illus. No.</u>	<u>Part No.</u>	<u>Qty.</u>	<u>Description</u>
1	815931	1	Microprocessor Temperature Sensor Bracket Complete (includes illus. nos. 1 through 10)
	820967	1	Microprocessor Temperature Sensor Bracket Only
2	150005	2	#6-32 x 1/4" Round Head Machine Screw
3	153010	2	#6 Star Washer
4	130103	1	225° Auto Reset Thermostat Only
5	152000	2	#6-32 Hex Nut
6	121028	2	1/4" x .032 Insulated Terminal
7	122701	4	Socket Terminal Only
8	122605	1	4-Pin Socket Connector
9	154007	2	1/4" Push-On Fastener
10	815961	1	1/4" Temperature Sensor Probe Assembly (includes illus. nos. 6 through 10)
11	150301	4	#8-18 x 7/16" Phillips Pan Head TEK Screw

# Totally Enclosed, Non-Venting Drive Motor Assembly

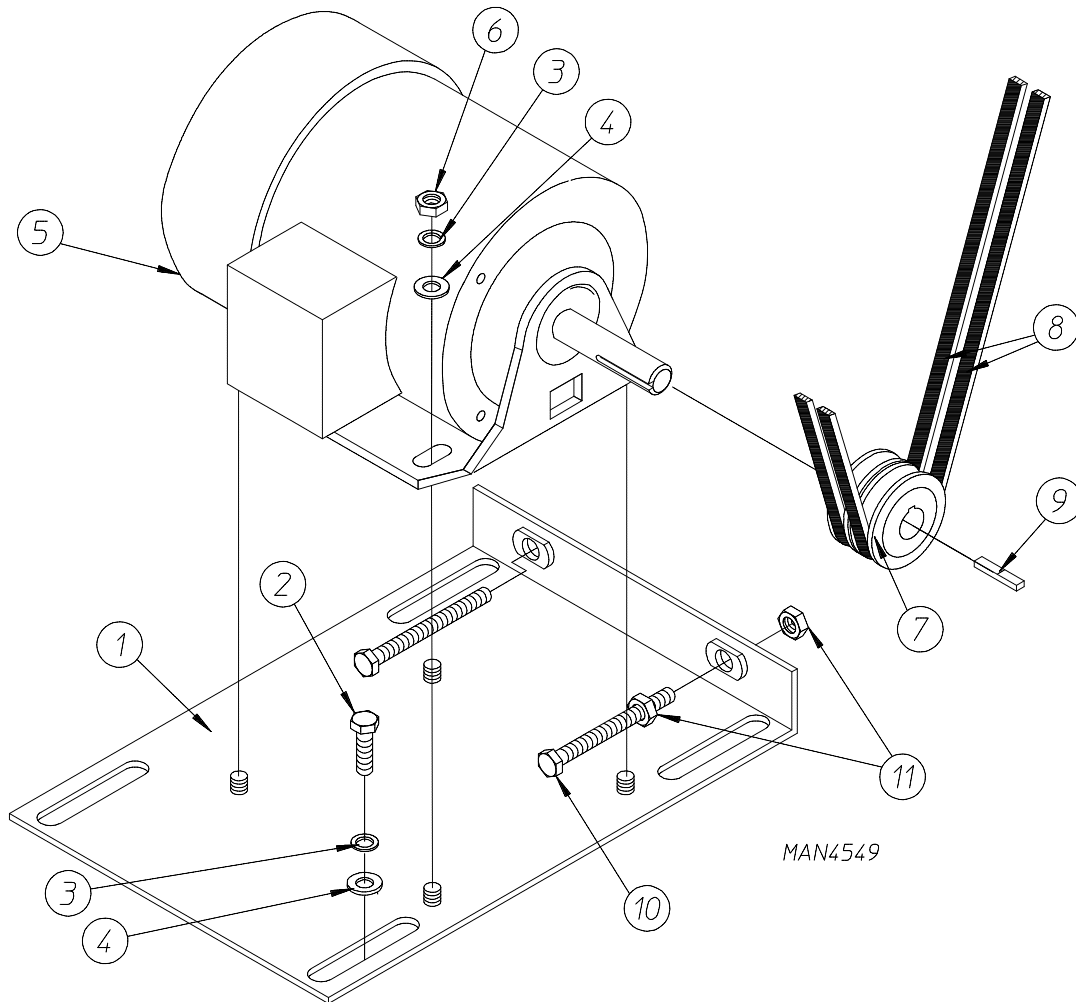

<u>Illus. No.</u>	<u>Part No.</u>	<u>Qty.</u>	<u>Description</u>
1	802253	1	Motor Adjustment Plate
2	150501	4	5/16-18 x 3/4" Hex Head Tap Bolt
3	153002	8	5/16" Lock Washer
4	153001	8	5/16" Flat Washer
5	100043	1	3 hp 208-230 / 460v 3ø 60 Hz Totally Enclosed, Non-Venting Motor 380-416v 3ø 50 Hz Totally Enclosed, Non-Venting Motor
	181019	1	3 hp 575v 3ø 60 Hz Totally Enclosed, Non-Venting Motor
6	152004	4	5/16" Hex Nut
7	101235	1	2MB35 x 1-1/8" Pulley
8*	100164	2	BX-51 V-Belt
9**	—	1	5/16" Key
10	150619	2	3/8-16 x 3" Tap Bolt
11	152005	4	3/8-16 Hex Nut

\* Replace in matched sets (both belts).

\*\* Consult factory.

# Blower Motor Mount Assembly

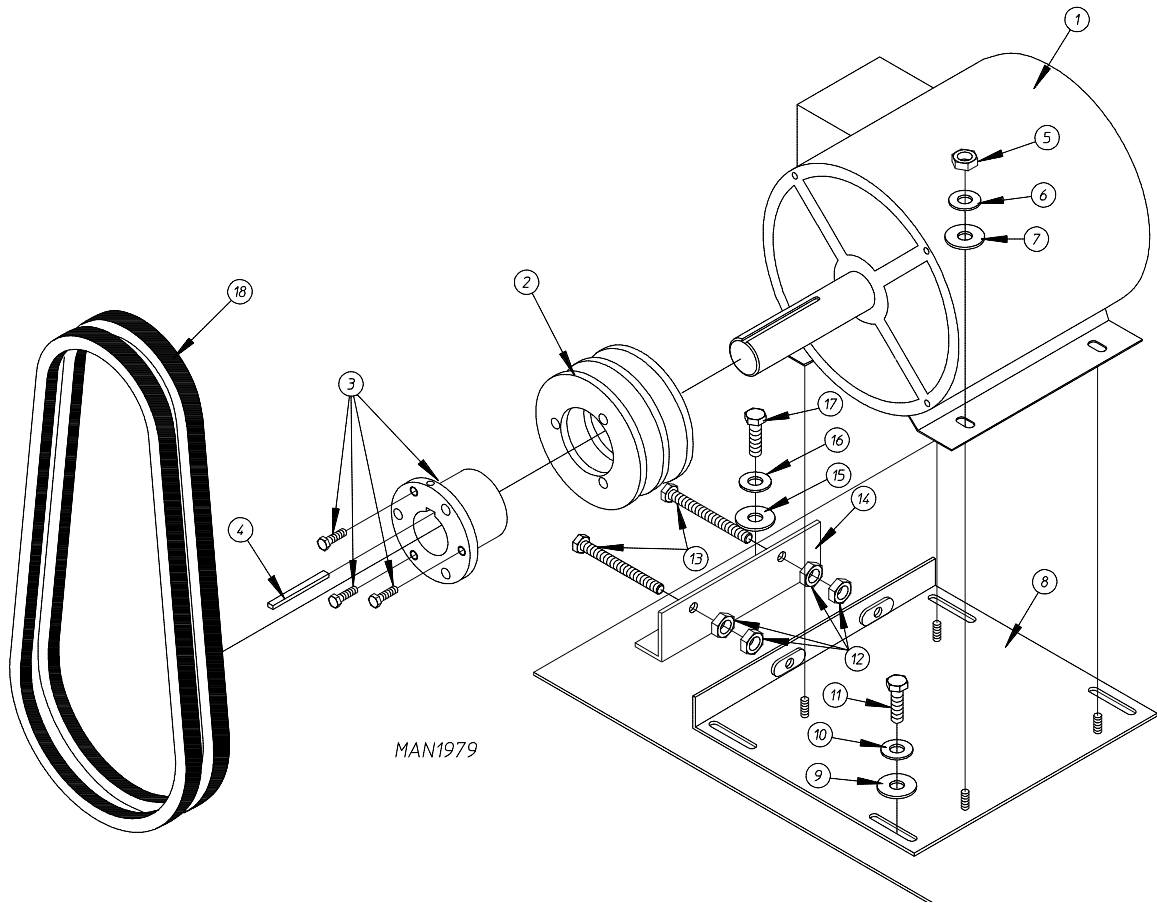

MAN1979

Illus. No.	Part No.	Qty.	Description
1	181030*	1	7.5 hp 208-230/460v 3ø 60 Hz Motor
	181031*	1	7.5 hp 200-230/380-410v 3ø 50 Hz Motor
	100021	1	7.5 hp 575v 3ø 60 Hz Motor
2	101148	1	SB x 4.0 Motor Pulley (60 Hz)
	101187	1	SB x 3.6 Motor Pulley (50 Hz)
3	101152	1	SH x 1-3/8" Bushing (60 Hz)
	101194	1	SDS x 1-3/8" Bushing (50 Hz)
4	100706	1	5/16" x 5/16" x 1-3/8" Key
5	152004	4	5/16-18 Hex Nut
6	153002	4	5/16" Lock Washer
7	153001	4	5/16" Flat Washer
8	821091	1	Motor Mount Adjustment Plate
9	153001	4	5/16" Flat Washer
10	153002	4	5/16" Lock Washer
11	150501	4	5/16-18 x 3/4" Hex Head Machine Bolt
12	152004	4	5/16-18 Hex Nut
13	150503	2	5/16-18 x 2" Hex Head Machine Bolt
14	332322	1	Motor Mount Adjustment Angle
15	153001	2	5/16" Flat Washer
16	153002	2	5/16" Lock Washer
17	150501	2	5/16-18 x 3/4" Hex Head Machine Bolt
18**	100184	2	BX-63 Cogged Belt (matched sets) 208-480 Volts 50/60 Hz

\* Specify voltage when ordering.

\*\* Replace in matched sets (both belts).

# Fan (Squirrel Cage) Shaft Mount Assembly

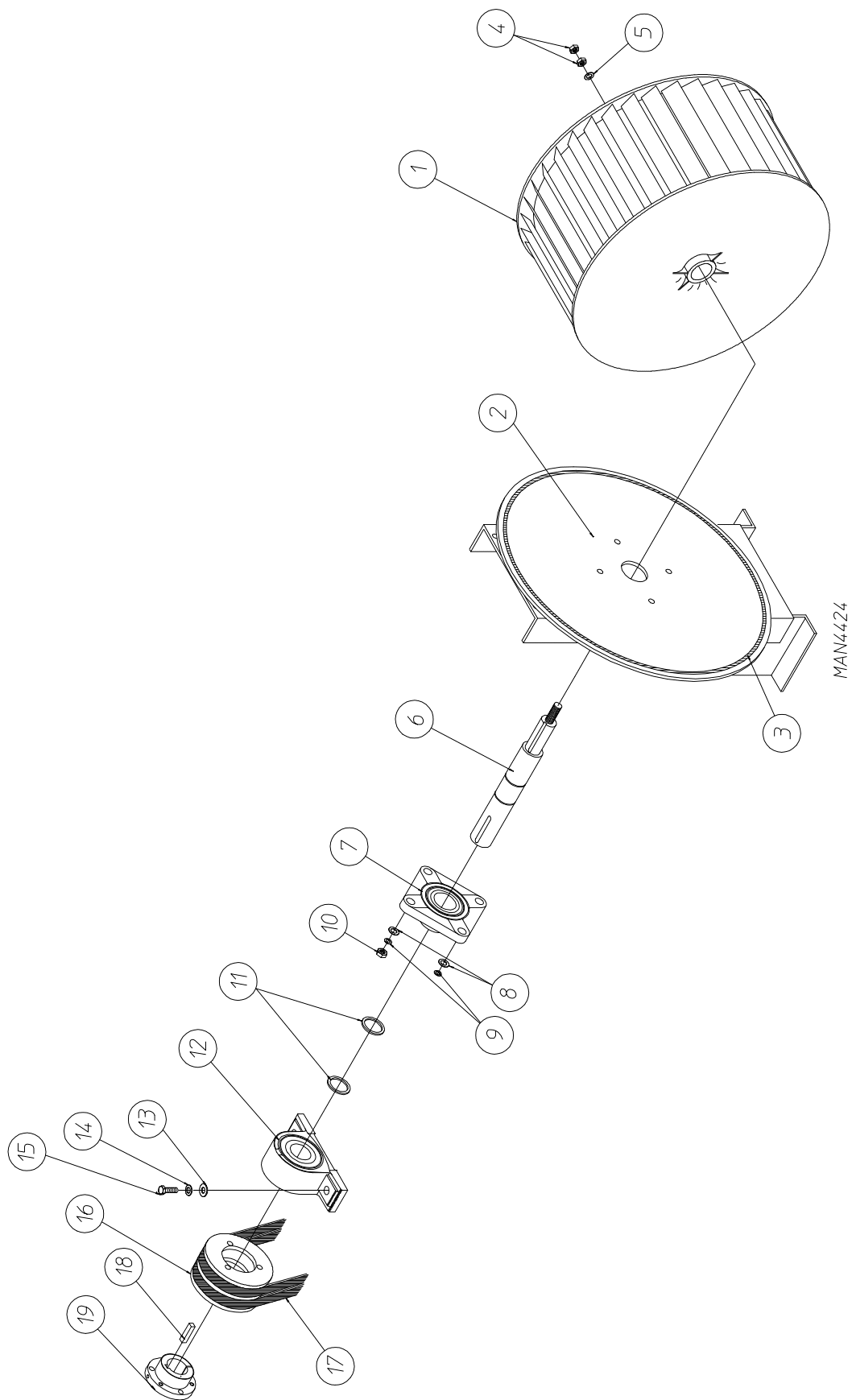

MAN4424

## Fan (Squirrel Cage) Shaft Mount Assembly

---

<u>Illus. No.</u>	<u>Part No.</u>	<u>Qty.</u>	<u>Description</u>
1	100612	1	1-1/4" Bore x 15" Diameter x 6" Blower / Fan (squirrel cage)
2	819053	1	Fan Shaft Mount Assembly Complete (includes illus. nos. 1 through 16, 18, and 19)
	821073	1	Fan Shaft Mount Only
3	117604	4	Neoprene Sponge Tape (sold by the foot)
4	152006	2	1/2-20 Left-Hand Jam Nut
5	153065	1	1/2" Flat Washer
6	332280	1	Fan Shaft
7	881061	1	1-3/8" Flange Bearing with Setscrews and Grease Fitting
8	153004	4	3/8" Flat Washer
9	153005	4	3/8" Lock Washer
10	152005	4	3/8-16 Hex Nut
11	100812	2	1-3/8" Retaining Ring
12	880879	1	1-3/8" Pillow Block Bearing
13	153004	2	3/8" Flat Washer
14	153005	2	3/8" Lock Washer
15	150617	2	3/8-16 x 1" Hex Head Bolt
16	101135	1	2B x 5.4 Pulley (for gas models Only)
17*	100184	2	BX-63 Cogged Belt (fan shaft to blower motor) 208-480 Volts 50/60 Hz
18	100706	1	5/16" x 5/16" x 1-3/8" Key
19	101194	1	SDS x 1-3/8" Bushing

\* Replace in matched sets (both belts).

# Direct Spark Ignition Burner Assembly

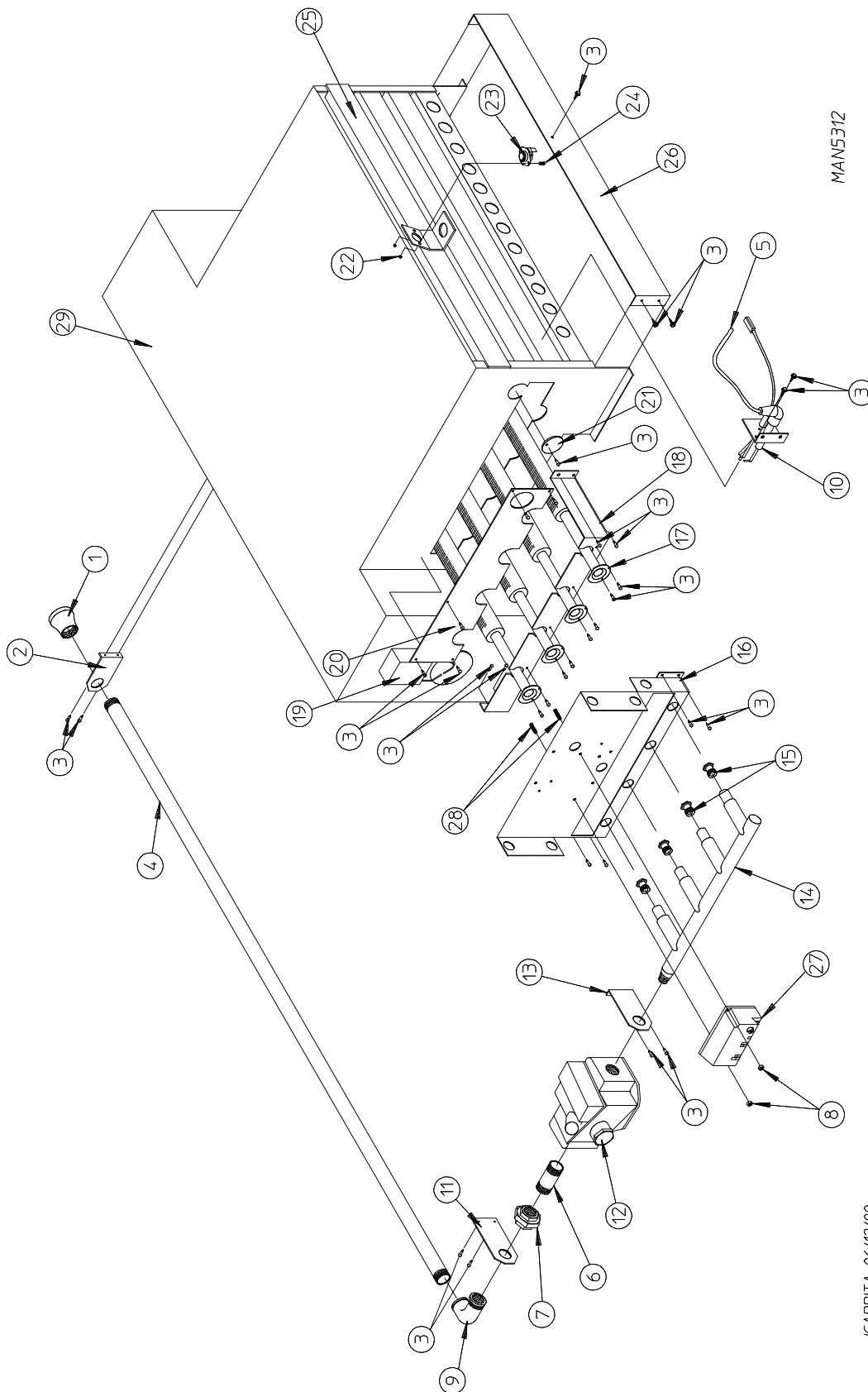

MAN5312

JCARRITA 06/12/00

## Direct Spark Ignition Burner Assembly

<u>Illus. No.</u>	<u>Part No.</u>	<u>Qty.</u>	<u>Description</u>
1	142929	1	1-1/2" to 1" Reducing Coupling
2	332117	1	Pipe Bracket
3	150309	33	#10-16 x 1/2" Hex Head TEK Crimptite Screw
4	142583	1	1" x 40" Nipple
5	829999	1	High Voltage Ignition Cable
6	142808	1	1" x 3" Nipple
7	142602	1	1" Union
8	152013	2	#6-32 Hex Nut
9	142507	1	1" x 90° Street Elbow
10	884265	1	Direct Spark Ignition Ignitor
11	332487	1	Gas Pipe Bracket Straight Extended
12	140017	1	1" 24 VAC Redundant Gas Valve (natural gas)
	882945	1	1" 24 VAC Gas Valve Liquid Propane
13	332486	1	Gas Pipe Bracket Bent Extended
14	141239	1	4-Port Manifold
15	140840*	4	#1 Burner Orifice (natural gas)
	140821*	4	#28 Burner Orifice (liquid propane gas)
16	390169	1	Direct Spark Ignition Mount Manifold Rest
17	881492	4	Burner Tube
18	332121	1	Burner Tube Support
19	————	1	Sail Switch <b>(refer to Sail Switch Assembly on page 24)</b>
20	332113	1	Burner Box Cover Plate
21	331290	1	Ignitor / Flame-Probe Sight Hole Disc
22	151000	2	#6-32 Pal Nut
23	130201	1	330° Manual Reset Hi-Limit
24	150005	2	#6-32 x 1/4" Phillips Round Head Machine Screw
25	821457	1	Burner Hi-Limit Bracket
26	332256	1	Large Dryer Liquid Propane Burner Baffle (liquid propane models Only)
27	887133	1	Direct Spark Ignition Module (3 tries) with High Voltage Wire
28	153562	2	#6-32 x 3/4" Clinch Stud
29	819066**	1	Burner Assembly (natural gas Only) Complete (less orifice)
	819067**	1	Burner Assembly (liquid propane gas Only) Complete (less orifice)
	820904	1	Burner Box Only
	882222*	1	ML-202 Liquid Propane Conversion Kit

\* Consult factory for elevations over 2,000 feet.

\*\* Orifices are not included and must be ordered separately.

# Sail Switch Assembly

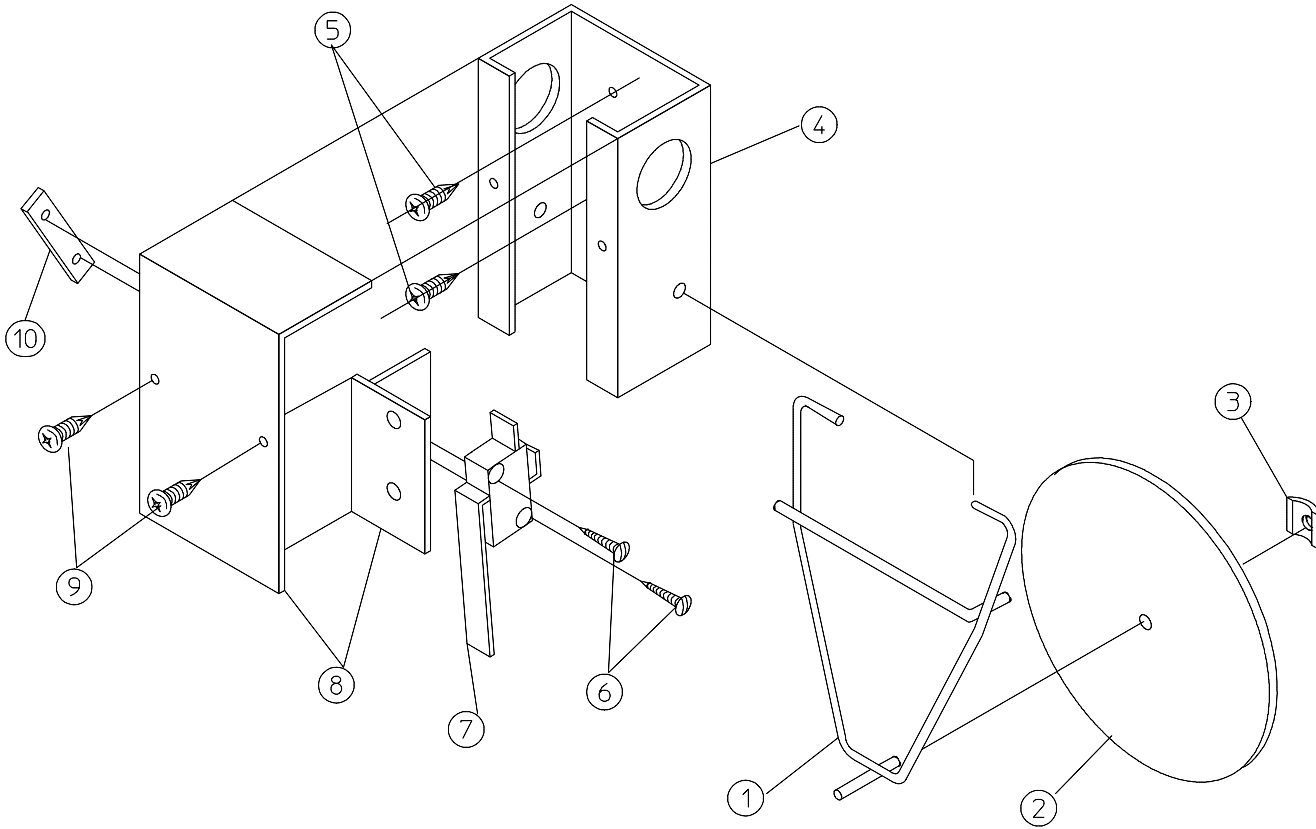

MAN0440

<u>Illus. No.</u>	<u>Part No.</u>	<u>Qty.</u>	<u>Description</u>
1	105500	1	Sail Switch Actuator Rod
2	319202	1	Sail Switch Damper (flat)
3	154002	1	1/8" Push-On Fastener
4	802800	1	Sail Switch Box with Cover and Bracket
	802801	1	Sail Switch Box Assembly Complete (includes illus. nos. 1 through 4 and 6 through 10)
5	150300	2	#10-16 x 1/2" Hex Washer
6	150303	2	#4 x 3/4" Pan Head "A" Machine Screw
7	122200	1	Sail Switch
8	802799	1	Sail Switch Box Cover and Bracket
9	150309	2	#10-16 x 1/2" Hex Head TEK Crimptite Screw
10	154004	1	Twin Speed Nut



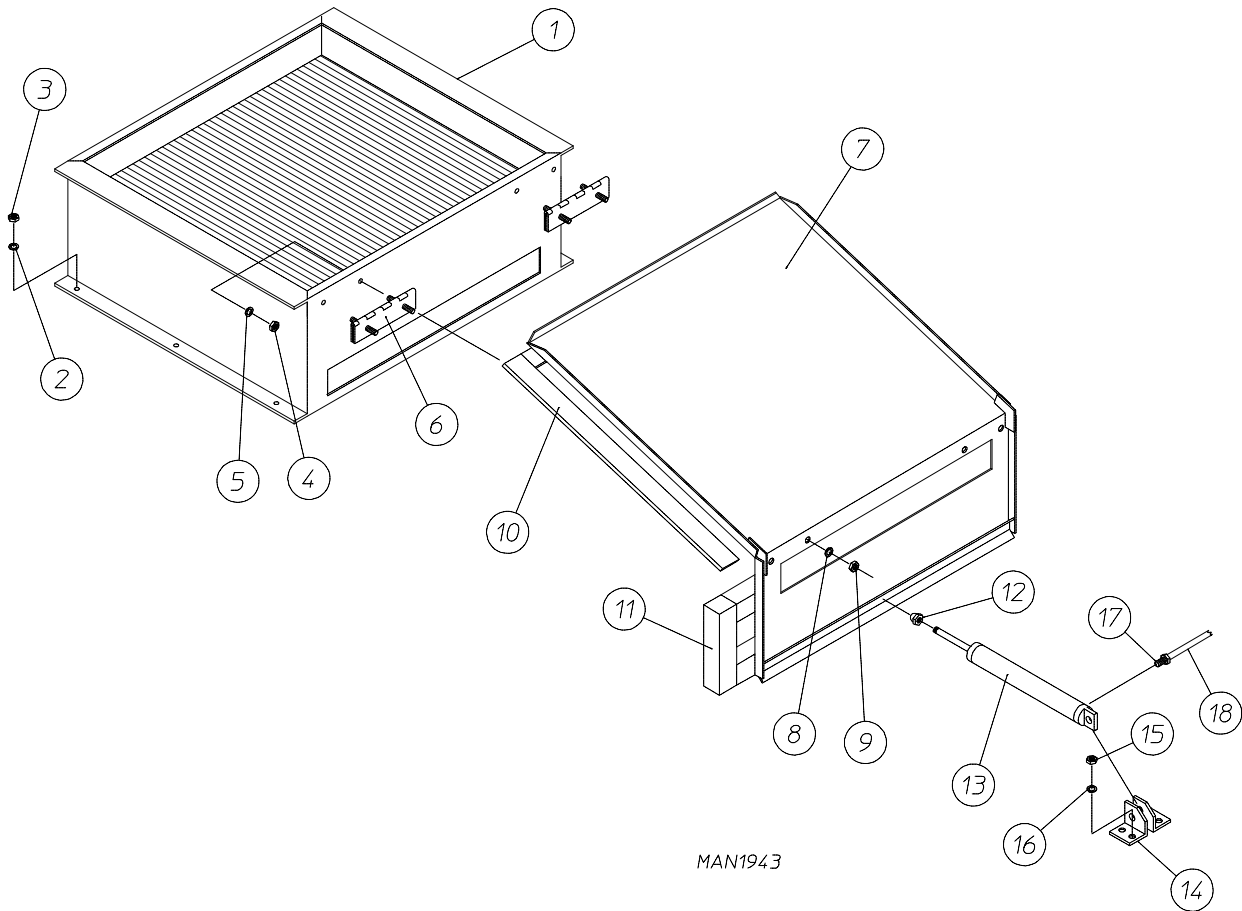

MAN1943

<u>Illus. No.</u>	<u>Part No.</u>	<u>Qty.</u>	<u>Description</u>
1	165092	1	Steam Coil
2	153002	6	5/16" Lock Washer
3	152004	6	5/16-18 Hex Nut
4	152002	4	1/4-20 Hex Nut
5	153007	4	1/4" Lock Washer
6	820321	2	Steam Damper Hinge Assembly
7	820994	1	Steam Damper Assembly (includes illus. nos. 7, 10, and 11)
8	153007	4	1/4" Lock Washer
9	152002	4	1/4-20 Hex Nut
10	115995	96	Steam Damper Gasket (sold by the inch)
11	102350	2	Steam Damper Foam (68-1/2" length)
12	151007	1	7/16-20 Stainless Steel Acorn Nut
13	100499	1	1-1/2" Bore x 3" Stroke Piston
14	100500	1	Piston Support Bracket
15	152002	4	1/4-20 Hex Nut
16	153007	4	1/4" Lock Washer
17	100472	1	1/4" x 1/8" Connector
18	143110	1	1/4" Tubing (sold by the foot)

# Top Console Assembly

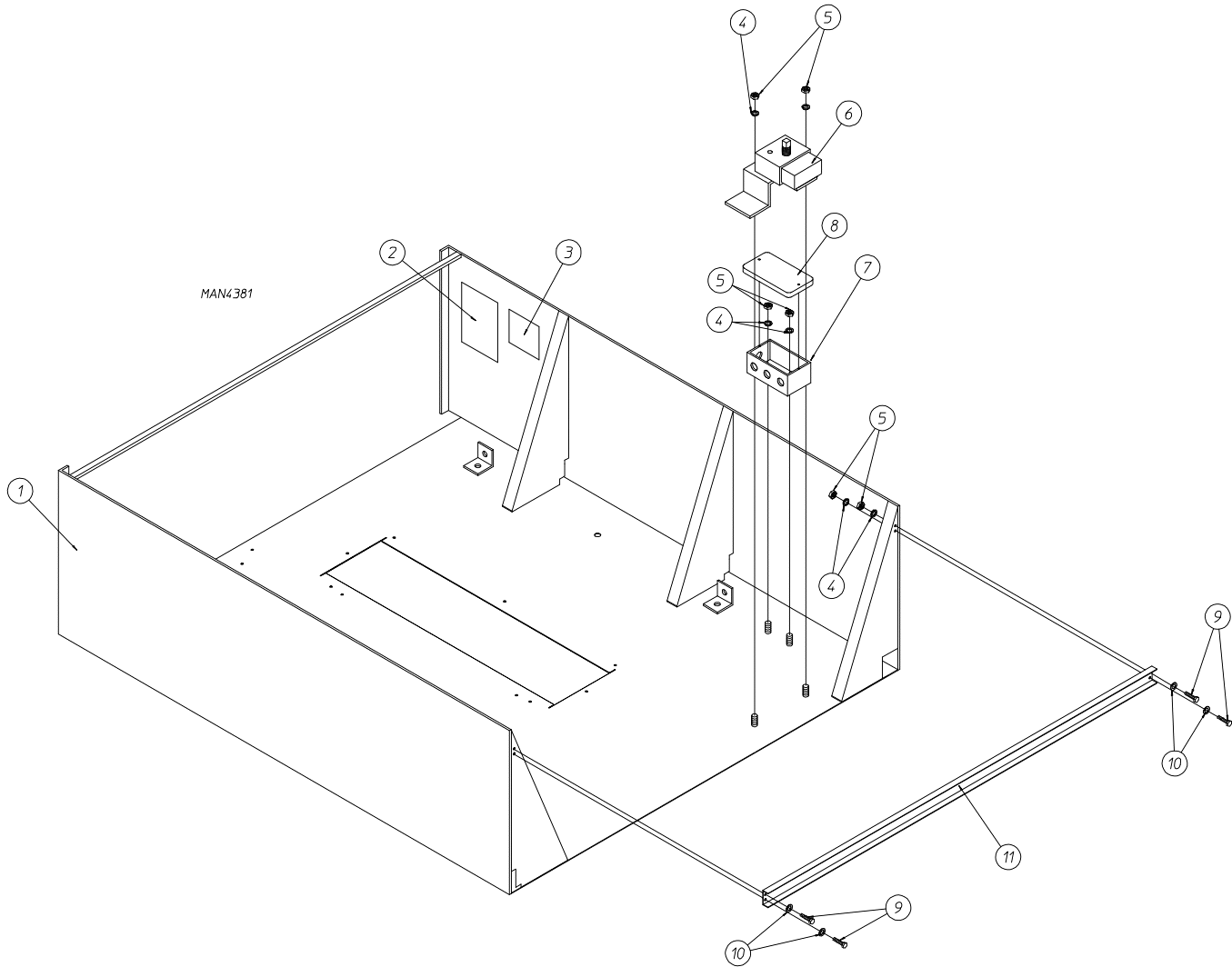

<u>Illus. No.</u>	<u>Part No.</u>	<u>Qty.</u>	<u>Description</u>
1*	819075	1	Top Console Assembly Only for Natural Gas Models
	819029	1	Top Console Assembly Only for Liquid Propane Gas Models
	819016	1	Top Console Assembly Only for Steam Models
2	114521	1	"Phase 7 Non-Coin Program Location Summary" Label
3	—	1	Dryer Data Label (not for resale by ADC)
4	153007	8	1/4" Lock Washer
5	152005	8	1/4-20 Hex Nut
6	821105	1	Pneumatic Valve Assembly Only for Gas Models <b>(refer to Pneumatic Valve Assembly on page 27)</b>
	821104	1	Pneumatic Valve Assembly Only for Steam Models <b>(refer to Pneumatic Valve Assembly on page 28)</b>
7	121104	1	2" x 4" Junction Box Only
8	121105	1	Junction Box Cover Only
9	150615	4	1/4-20 x 3/4" Bolt
10	153018	4	1/4" Flat Washer
11	332186	1	Control Door Hinge Channel

\* Specify color when ordering.

# Pneumatic Valve Assembly

For Gas Models Only

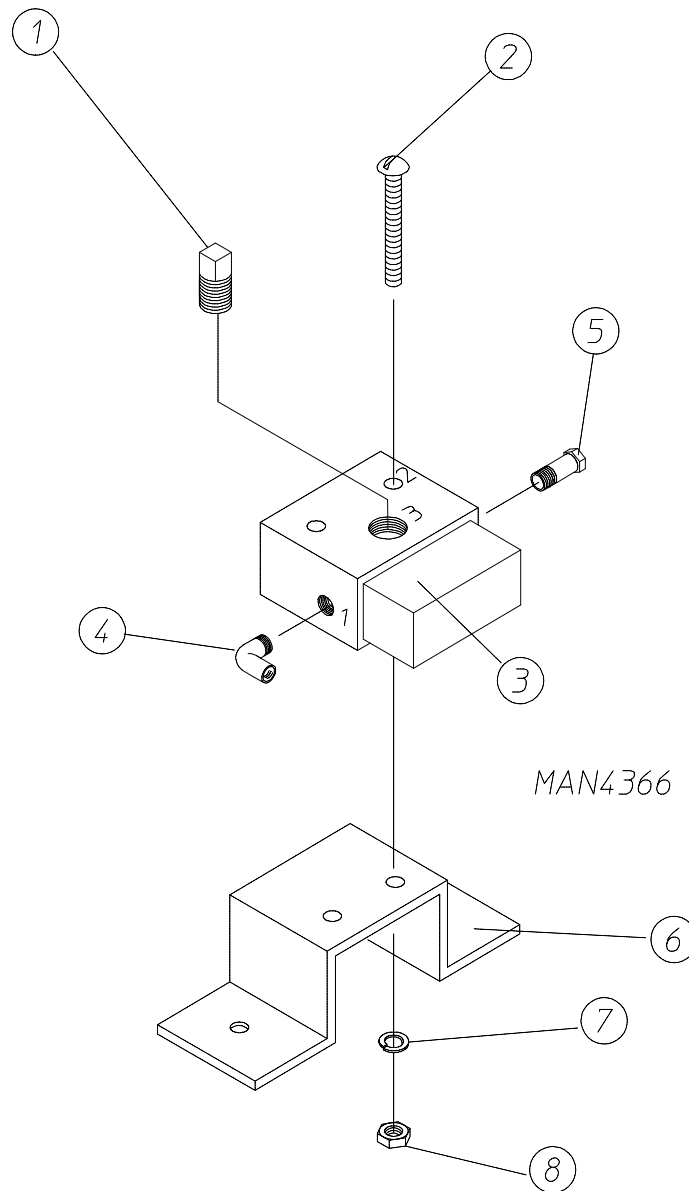

<u>Illus. No.</u>	<u>Part No.</u>	<u>Qty.</u>	<u>Description</u>
1	143250	1	1/8" M.P.T. Brass Plug
2	150002	1	#6-32 x 1" Slotted Machine Screw
3	100498	1	3-Way Micro Valve Only – 24VAC
	821105	1	Pneumatic Valve Assembly Complete (includes illus. nos. 1 through 8)
4	143149	1	1/4" Poly x 1/8" M.P.T. Elbow
5	100472	1	1/4" x 1/8" Connector
6	330987	1	Micro Valve Support Bracket Only
7	153010	1	#6 Star Washer
8	152000	1	#6-32 Hex Nut

# Pneumatic Valve Assembly

For Steam Models Only

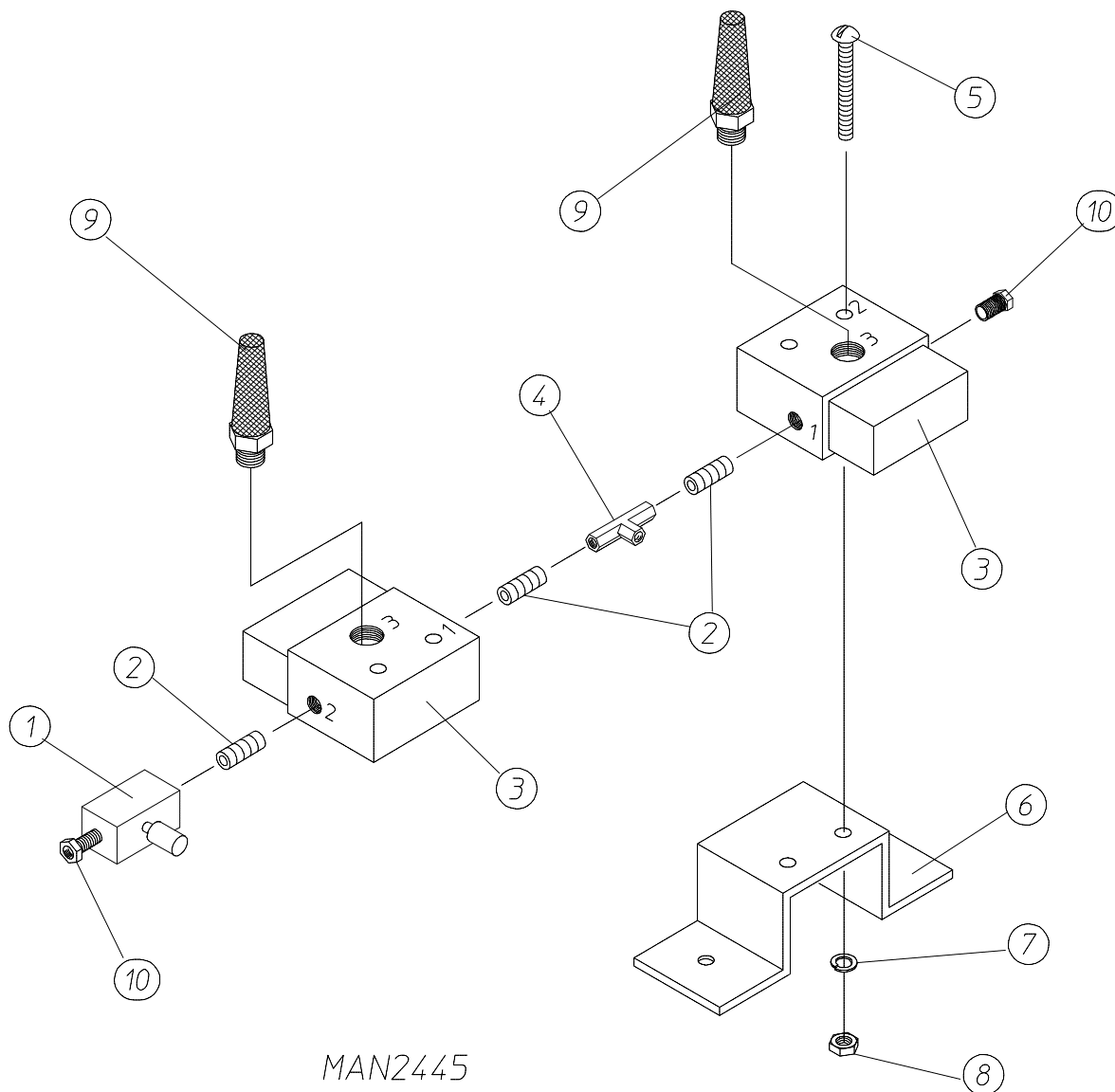

MAN2445

<u>Illus. No.</u>	<u>Part No.</u>	<u>Qty.</u>	<u>Description</u>
1	100496	1	1/8" Needle Valve
2	143238	3	1/8" Close Nipple
3	100498	2	3-Way Micro Valve Only – 24VAC
	821104	1	Pneumatic Valve Assembly Complete (includes illus. nos. 1 through 10)
4	143223	1	1/8" F.P.T. Brass Tee
5	150002	2	#6-32 x 1" Slotted Machine Screw
6	330987	1	Micro Valve Support Bracket Only
7	153010	2	#6 Star Washer
8	152000	2	#6-32 Hex Nut
9	100520	2	1/8" N.P.T. Silencer (muffler)
10	100472	2	1/4" x 1/8" Connector

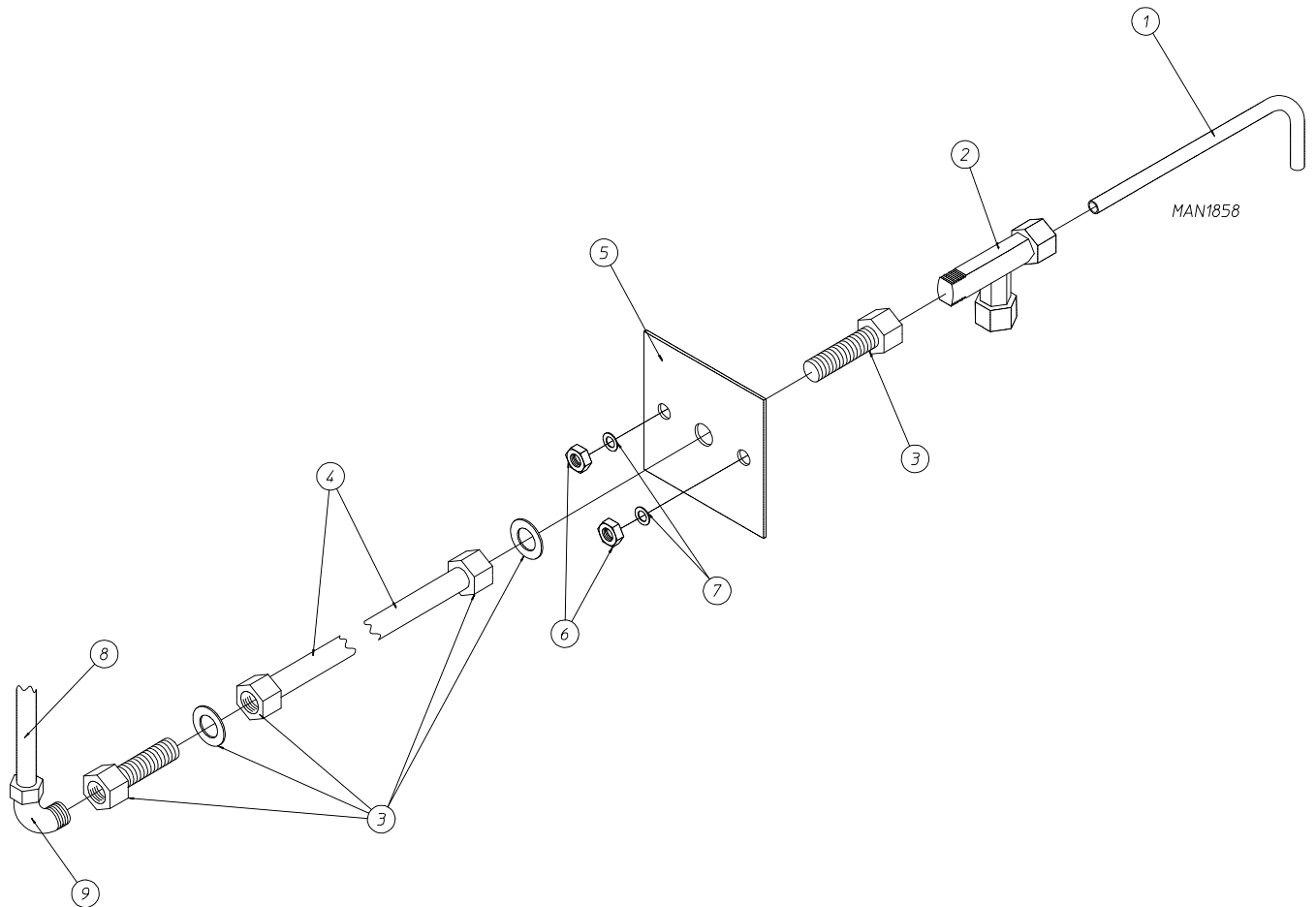

<u>Illus. No.</u>	<u>Part No.</u>	<u>Qty.</u>	<u>Description</u>
1	332700	1	Air Jet Tube
2	143287	1	1/4" x 1/8" M.P.T. Male Run Tee
3	143259	2	1/4" x 1/8" F.P.T. Bulkhead Fitting
4	143100	36	1/4" Aluminum Tube (sold by the inch)
5	821081	1	Air Jet Mounting Plate Assembly (includes illus. nos. 1 through 9)
	332531	1	Air Jet Mounting Plate Only
6	152002	2	1/4-20 Hex Nut
7	153007	2	1/4" Lock Washer
8	143110	5	1/4" Poly-Flo Tubing (sold by the foot)
9	143149	1	1/4" x 1/8" M.P.T. x 90° Elbow

# Reversing Relay Panel Assembly

For 208-240 Volts

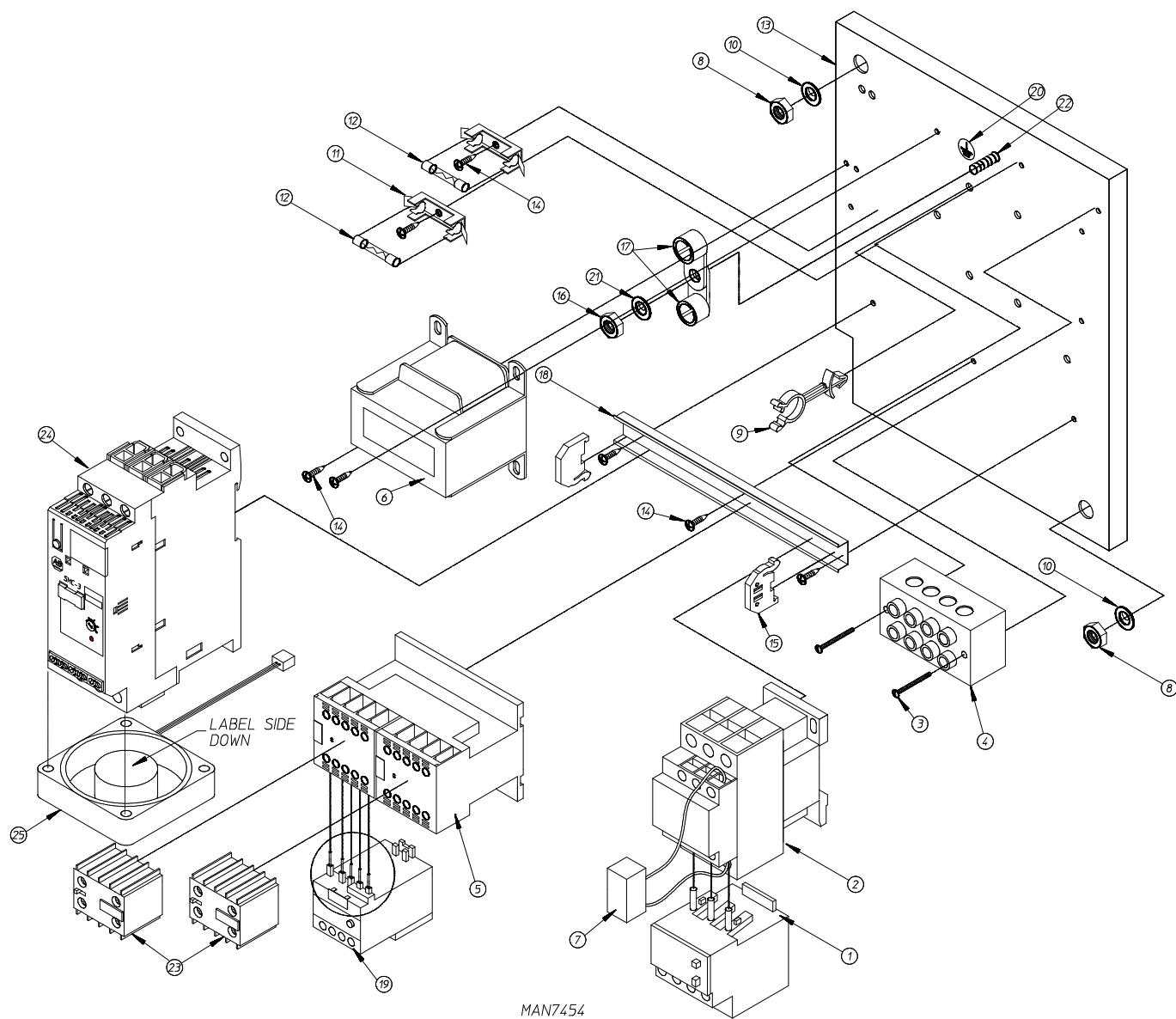

# Reversing Relay Panel Assembly

For 208-240 Volts

<u>Illus. No</u>	<u>Part No.</u>	<u>Qty.</u>	<u>Description</u>
1	801890	1	5-27A Overload Assembly
2	131393	1	32-amp Contactor
3	150539	2	#8 x 1-1/4" Phillips Pan Head Zinc Screw
4	120701	1	4-Position Terminal Block
5	132513	1	Reversing Contactor with Coil Suppression
6	132109	1	208-240V Transformer Assembly
7	137015	1	Arc Suppressor with 3" Leads
8	152004	2	5/16-18 Hex Nut
9	121502	1	1/2" Wire Standoff
10	153002	2	5/16" Lock Washer
11	136008	2	Fuse Holder
12	136057	2	1/2-amp 3AG Slo-Blo Fuse
13	332346	1	Relay Panel
14	150301	7	#8-18 x 7/16" Phillips Head TEK Screw
15	120774	2	End Stop for Din Rail
16	152002	1	1/4-20 Hex Nut
17	121010	2	L70 14-4 Terminal Lug
18	120768	8-1/2"	Din Rail (sold by the inch)
19	801890	1	5-27 Overload Assembly
20	112075	1	Ground Label
21	153021	1	1/4" Lock Washer
22	153525	1	1/4-20 x 1" Self-Clinching Stud
23	132449	2	Auxiliary Contact Block 2 Normally Open
24	132275	1	Softstart 16A 100-240VAC Control
25	132282	1	Softstart Fan

# Reversing Relay Panel Assembly

For 460-480 Volts

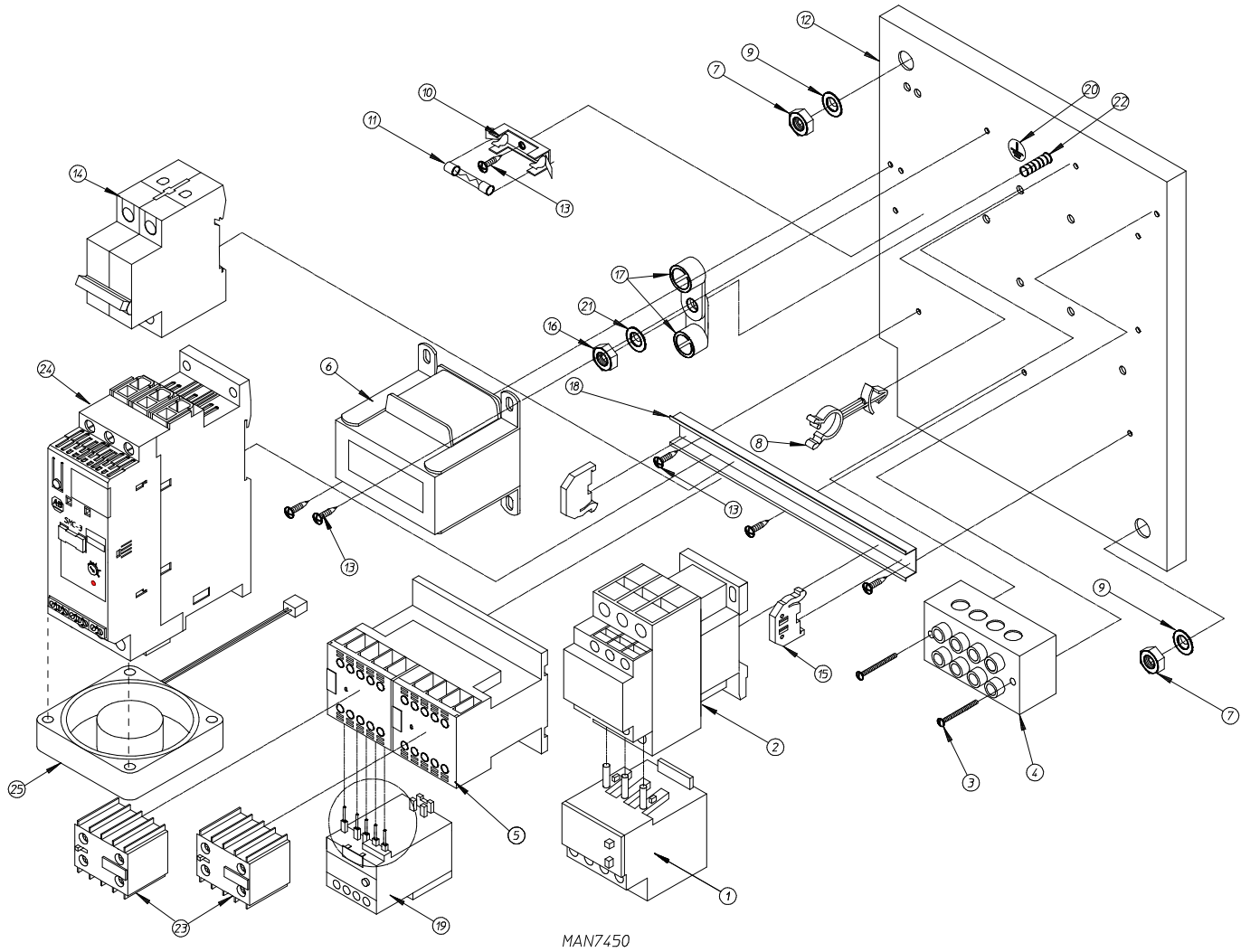



# Reversing Relay Panel Assembly

For 460-480 Volts

<u>Illus. No.</u>	<u>Part No.</u>	<u>Qty.</u>	<u>Description</u>
1	801890	1	5-27A Overload Assembly
2	131393	1	18-amp Contactor
3	150539	2	#8 x 1-1/4" Phillips Pan Head Zinc Screw
4	120701	1	4-Position Terminal Block
5	132497	1	Reversing Contactor
6	823252	1	460V Transformer Assembly
7	152004	2	5/16-18 Hex Nut
8	121502	1	1/2" Wire Standoff
9	153002	2	5/16" Lock Washer
10	136008	1	Fuse Holder
11	136057	1	1/2-amp 3AG Slo-Blo Fuse
12	322346	1	Relay Panel
13	150301	7	#8-18 x 7/16" Phillips Head TEK Screw
14	136113	1	Double Pole Class CC Fuse Holder
	136119	2	3/4-amp Time Delay CC Fuse
15	120774	2	End Stop for Din Rail
16	152002	1	1/4-20 Hex Nut
17	121010	2	L70 14-4 Terminal Lug
18	120768	8-1/2"	Din Rail (sold by the inch)
19	801891	1	1-5A Overload Assembly
20	112075	1	Ground Label
21	153021	1	1/4" Lock Washer
22	153525	1	1/4-20 x 1" Self-Clinching Stud
23	132449	2	Auxiliary Contact Block 2 Normally Open
24	132276	1	Softstart 9A 100-240VAC Control
25	132282	1	Softstart Fan

# Fire Suppression System Temperature Probe Assembly

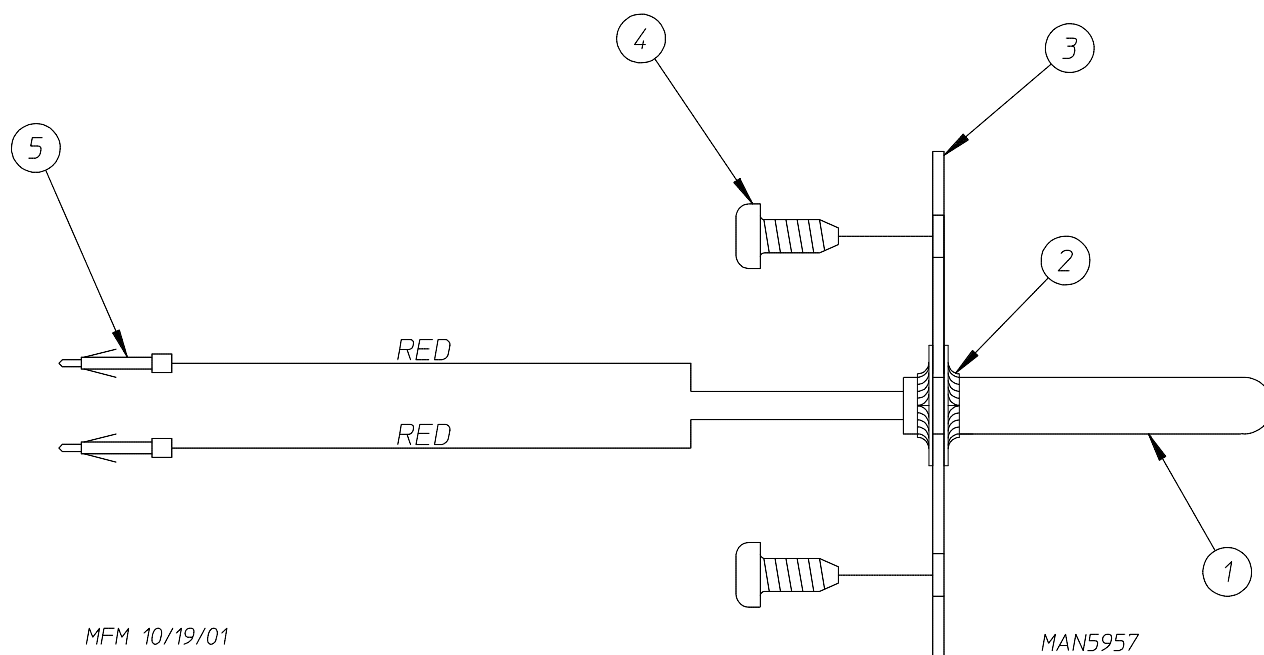

<u>Illus. No.</u>	<u>Part No.</u>	<u>Qty.</u>	<u>Description</u>
1	822752	1	Fire Suppression System Temperature Probe Assembly (includes illus. nos. 1 through 5)
2	154007	2	Push-On Fastener
3	390390	1	Sensor Bracket
4	150301	2	#8-18 Phillips Pan Head TEK Screw
5	122647	1	Connector ... Not Illustrated (does not include pins)
	122700	2	Pin

# Fire Suppression System Solenoid Assembly

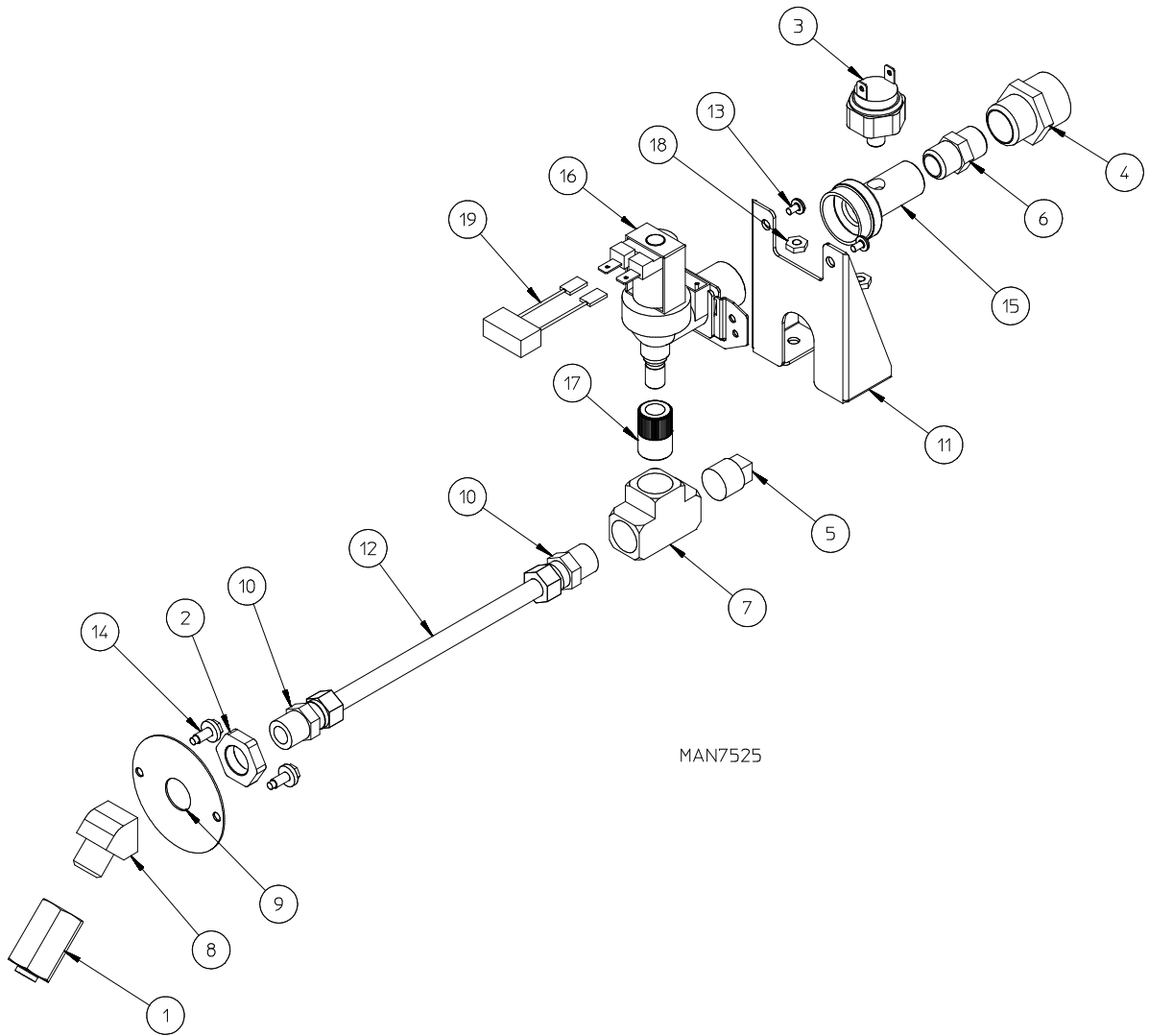

MAN7525

<u>Illus. No.</u>	<u>Part No.</u>	<u>Qty.</u>	<u>Description</u>
1	143581	1	Fire Suppression System 3 GPM 3/8" N.P.T. Spray Nozzle
2	143303	1	3/8" N.P.T. Brass Lock Nut
3	136987	1	Water Jet Pressure Switch
4	143356	1	3/4"-11.5 NH x 3/8" N.P.T. Nylon Hose Adapter
5	143251	1	3/8" M.P.T. Brass Plug
6	182579	1	3/8" M.P.T. x 3/8" M.P.T. Brass Hex Nipple
7	143220	1	3/8" F.P.T. Brass Tee
8	143301	1	3/8" Brass 45° Street Elbow
9	311588	1	Fire Suppression System Sprinkler Head Mounting Plate
10	143208	2	3/8" Comp x 3/8" M.P.T. Brass Connector
11	311587	1	Medium Dryer Fire Suppression System Valve Bracket
12	143108	1	20" Stainless Steel Flex Hose with 3/8" Compression
13	154338	2	M4 x 6mm Phillips Head Slotted Machine Screw
14	150309	2	#10-16 x 1/2" Hex Head TEK Crimptite
15	143182	1	3/4" GHT x 1/8" x 3/8" N.P.T. Brass Tee
16	165119	1	Fire Suppression System Water Inlet Valve
17	143183	1	7/16-20 x 3/8" N.P.T. Brass Adapter 2
18	152001	2	#8-32 3/8" Hex Nut
19	824081	1	R.C. Network Assembly

# Back Guard Assemblies

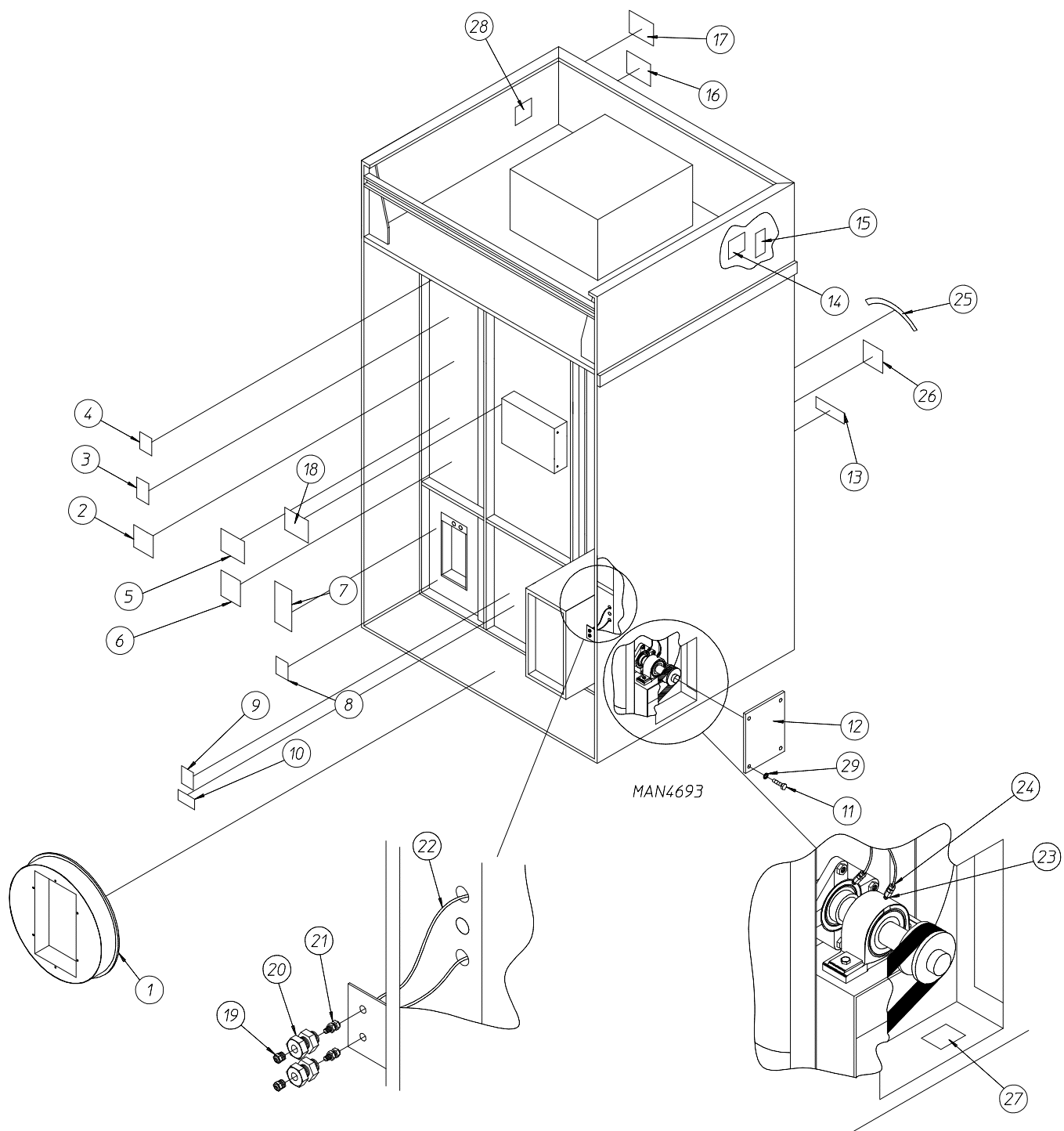

<u>Illus. No.</u>	<u>Part No.</u>	<u>Qty.</u>	<u>Description</u>
1	821793	1	Square Duct to 20" Round Duct Transition Piece Assembly with Damper
	821956	1	Square Duct to 20" Round Duct Transition Piece Assembly
	821720	1	Square Duct to 18" Round Duct Transition Piece Assembly with Damper
	821092	1	Square Duct to 18" Round Duct Transition Piece Assembly
2	-----	1	Wiring Diagram for Dryer (contact factory with model and serial numbers)
3	112046	1	"Computer Ground" Label
4	114005	1	"Danger – Hot" Label
5	112519	1	"Routine Maintenance" Label
6	114044	1	"High Voltage" Label
7	114007	1	"Danger – High Voltage" Label
8	112014	1	"High Voltage" Label
9	114008	1	"Warning – Fumes" Label
10	114001	1	"Caution – Exhaust / Lint Screen" Label
11	150512	4	1/4-20 x 1/2" Hex Head Machine Bolt
12	332309	1	Side Access Panel
13	112280	1	"Clean Lint Screen" Label
14	112017	1	"Address" Label (not for resale)
15	-----	1	"Serial Number" Label (not for resale)
16	-----	1	Wiring Diagram (contact factory with specific dryer serial number)
17	114521	1	"Phase 7 Non-Coin Program Location" Label
18	114093	1	"Important Manual Reset Hi-Limit" Label
19	170511	2	1/8" M.P.T. Zirc (grease) Fitting
20	143164	2	1/8" F.P.T. Bulkhead Fitting
21	100472	2	1/4" x 1/8" M.P.T. Male Connector
22	143115	4	1/4" Nylo-Seal Tube
23	100472	2	1/4" x 1/8" M.P.T. Male Connector
24	143246	2	1/4-28 x 18" F.P.T. Fitting
25	114095	1	"Do Not Dry Mop Heads" Label
26	114006	1	"WARNING – Fire Hazard" Label
27	114077	1	"Grease Instruction" Label
28	114093	1	"Important Manual Reset Hi-Limit" Label
29	153007	4	1/4" Lock Washer

