



ML-758 Parts Manual

Phase 7 / Non-Coin / Dual Timer

with F.S.S. Options

Whirlpool Corporation

88 Currant Road, Fall River MA 02720-4781 USA

Telephone: +1 (269) 759-6044

e-mail: mdl-parts@whirlpool.com

www.adclaundry.com

Retain This Manual In A Safe Place For Future Reference

ADC products embody advanced concepts in engineering, design, and safety. If this product is properly maintained, it will provide many years of safe, efficient, and trouble free operation.

ONLY qualified technicians should service this equipment.

OBSERVE ALL SAFETY PRECAUTIONS displayed on the equipment or specified in the installation manual included with the dryer.

The following “**FOR YOUR SAFETY CAUTION**” must be posted near the dryer in a prominent location.

FOR YOUR SAFETY

Do not store or use gasoline or other flammable vapors and liquids in the vicinity of this or any other appliance.

POUR VOTRE SÉCURITÉ

Ne pas entreposer ni utiliser d'essence ni d'autres vapeurs ou liquides inflammables à proximité de cet appareil ou de tout autre appareil.

We have tried to make this manual as complete as possible and hope you will find it useful. ADC reserves the right to make changes from time to time, without notice or obligation, in prices, specifications, colors, and material, and to change or discontinue models.

Important

For your convenience, log the following information:

DATE OF PURCHASE _____ MODEL NO. **ML-758**

RESELLER'S NAME _____

Serial Number(s) _____

The illustrations on the following pages may not depict your particular dryer exactly. The illustrations are a composite of the various dryer models. Be sure to check the descriptions of the parts thoroughly before ordering.

“IMPORTANT NOTE TO PURCHASER”

Information must be obtained from your local gas supplier on the instructions to be followed if the user smells gas. These instructions must be posted in a prominent location near the dryer.

Table of Contents

Phase 7 Non-Coin Microprocessor Control Door Assembly For Models Mfd. as of July 10, 2002	4
Dual Timer Non-Coin Control Door Assembly For Models Mfd. as of July 10, 2002	5
Phase 7 Non-Coin Microprocessor Control Door Assembly For Models Mfd. prior to July 10, 2002	6
Dual Timer Control Door Assembly For Models Mfd. prior to July 10, 2002	7
Phase 7 Non-Coin Microprocessor Control Panel Assembly	8
Dual Timer with Illuminated Green Start Button For Models Mfd. as of June 29, 2011	9
Dual Timer “Tap Touch” Controls For Models Mfd. prior to June 29, 2011	10
Phase 7 Non-Coin Microprocessor Control Box Assembly	11
Dual Timer Control Box Assembly	12
37-1/4” Main Door Assembly	13
Main Door Switch Assembly	14
Front Panel Assembly	15
Lint Drawer / Lint Drawer Switch Assembly	16
Tumbler / Support Assemblies	17
Tumbler Bearing Assembly For Models with Setscrew Type Bearings	18
Tumbler Bearing Assembly For Models with Grip Lock Type Bearings	20
Idler Bearing Assembly	21
Non-Reversing Motor Mount Assembly	22
Reversing Motor Mount Assembly	24
Sensor Bracket Assemblies	26
Direct Spark Ignition Burner Assembly	28
Electric Oven Assembly For Models Mfd. as of June 30, 2014	30
Electric Oven Assembly For Models Mfd. prior to June 30, 2014	32
Air-Operated Steam Damper Assembly	34
Fire Suppression System Assembly For Models Mfd. as of November 8, 2011	35
Fire Suppression System Assemblies For Models Mfd. prior to November 8, 2011	36
Single-Phase (1 ϕ) Microprocessor Rear Electric Relay Panel Assembly	37
208-240V 3-Phase (3 ϕ) Microprocessor Rear Electric Relay Panel Assembly	38
460-480V Microprocessor Rear Electric Relay Panel Assembly	39
208-240V Microprocessor Reversing Rear Electric Relay Panel Assembly	40
460-480V Microprocessor Reversing Rear Electric Relay Panel Assembly	41
Single-Phase (1 ϕ) Dual Timer Rear Electric Relay Panel Assembly	42
460-480V Dual Timer Rear Electric Relay Panel Assembly	43
208-240V Dual Timer Reversing Rear Electric Relay Panel Assembly	44
Outer Top / Back Guard Assemblies For Models Mfd. as of January 5, 2003	45
Outer Top / Back Guard Assemblies For Models Mfd. prior to January 5, 2003	46
Microprocessor Electric Oven Component Application Chart	47
Dual Timer Electric Oven Component Application Chart	48
Additional Parts Available	49

Phase 7 Non-Coin Microprocessor Control Door Assembly

For Models Mfd. as of July 10, 2002

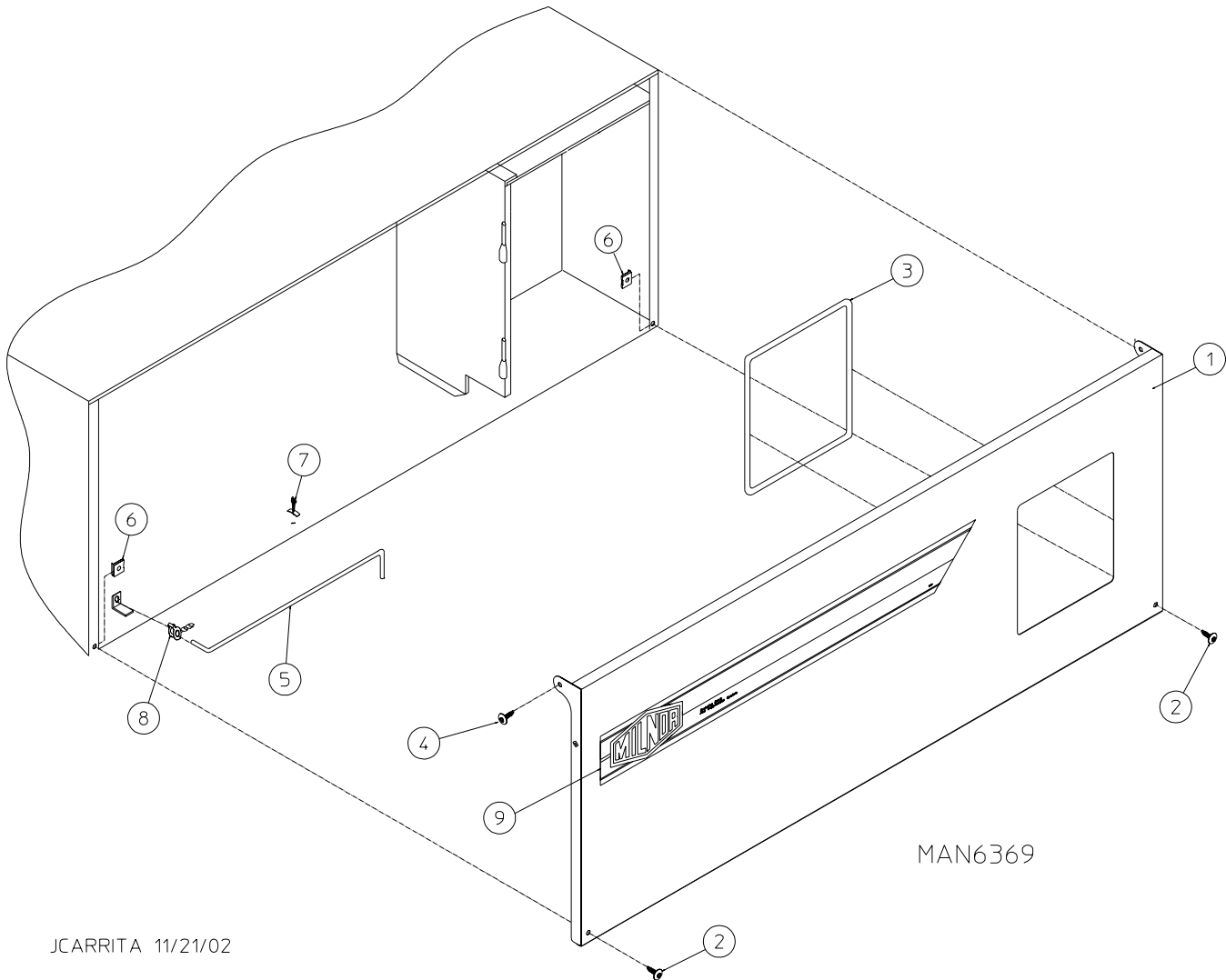

Illus. No.	Part No.	Qty.	Description
1	883576	1	White Non-Coin Control Door (includes illus. nos. 1 and 3)
2	150321	2	#10-32 x 1/2" Phillips Machine Screw
3	117604	4	Noise Suppression Tape (sold by the foot)
4	150317	2	#10-16 x 3/4" TORX PLUS®
	150318	1	TORX PLUS® Bit 1/4" (for removal of TORX® head screw)
5	102502	1	Control Door Support Rod
6	154011	2	#10-32 Multi-Thread U-Nut
7	102603	1	Control Door Rod Support Latch
8	102601	1	Control Door Rod Retainer Clip
9	-----*	1	Logo ONLY

* Contact reseller for logo.

Dual Timer Non-Coin Control Door Assembly

For Models Mfd. as of July 10, 2002

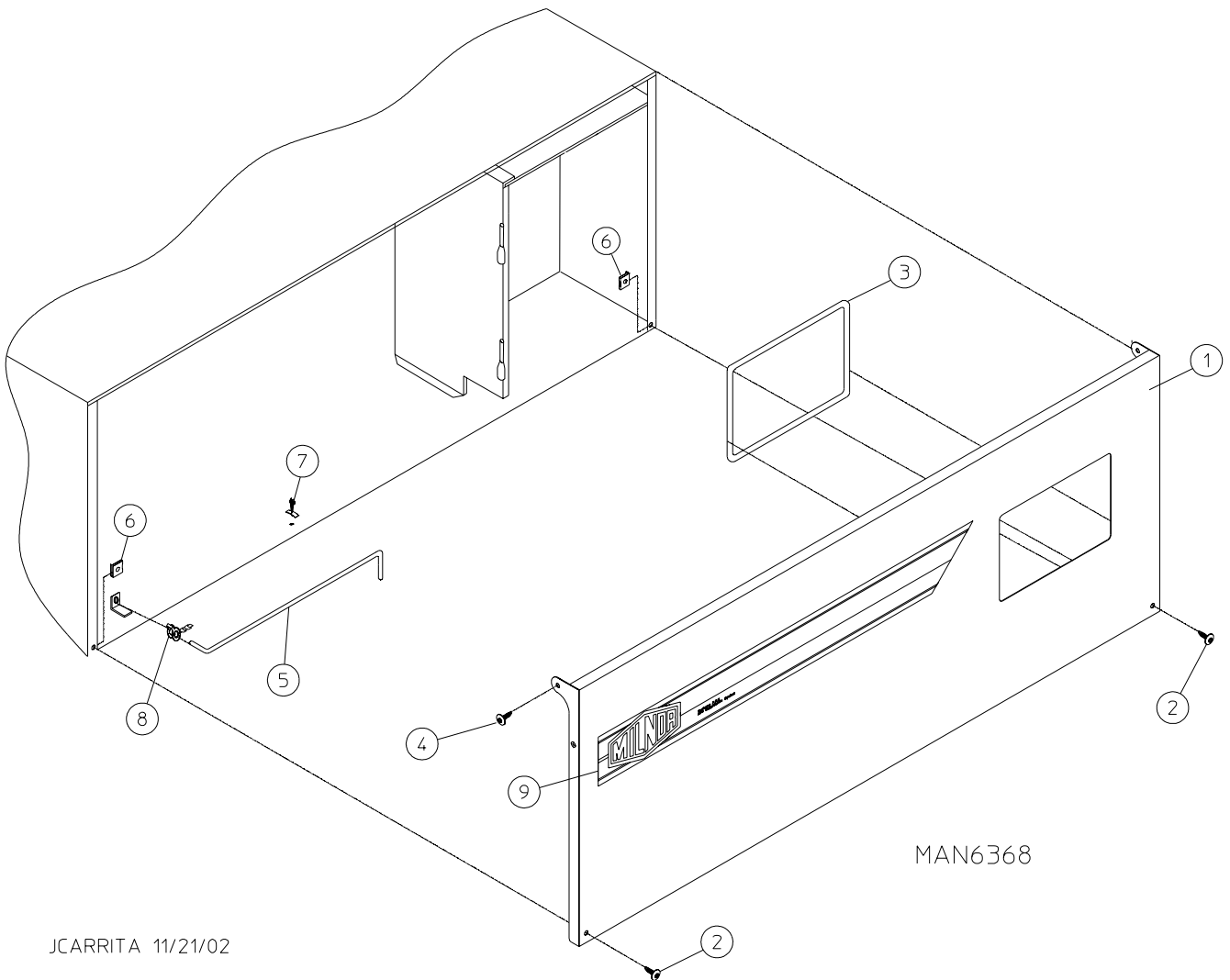

Illus. No.	Part No.	Qty.	Description
1	883616	1	White Non-Coin Control Door (includes illus. nos. 1 and 3)
2	150321	2	#10-32 x 1/2" Phillips Machine Screw
3	117604	4	Noise Suppression Tape (sold by the foot)
4	150317	2	#10-16 x 3/4" TORX PLUS®
	150318	1	TORX PLUS® Bit 1/4" (for removal of TORX® head screw)
5	102502	1	Control Door Support Rod
6	154011	2	#10-32 Multi-Thread U-Nut
7	102603	1	Control Door Rod Support Latch
8	102601	1	Control Door Rod Retainer Clip
9	-----*	1	Logo ONLY

* Contact reseller for logo.

Phase 7 Non-Coin Microprocessor Control Door Assembly

For Models Mfd. prior to July 10, 2002

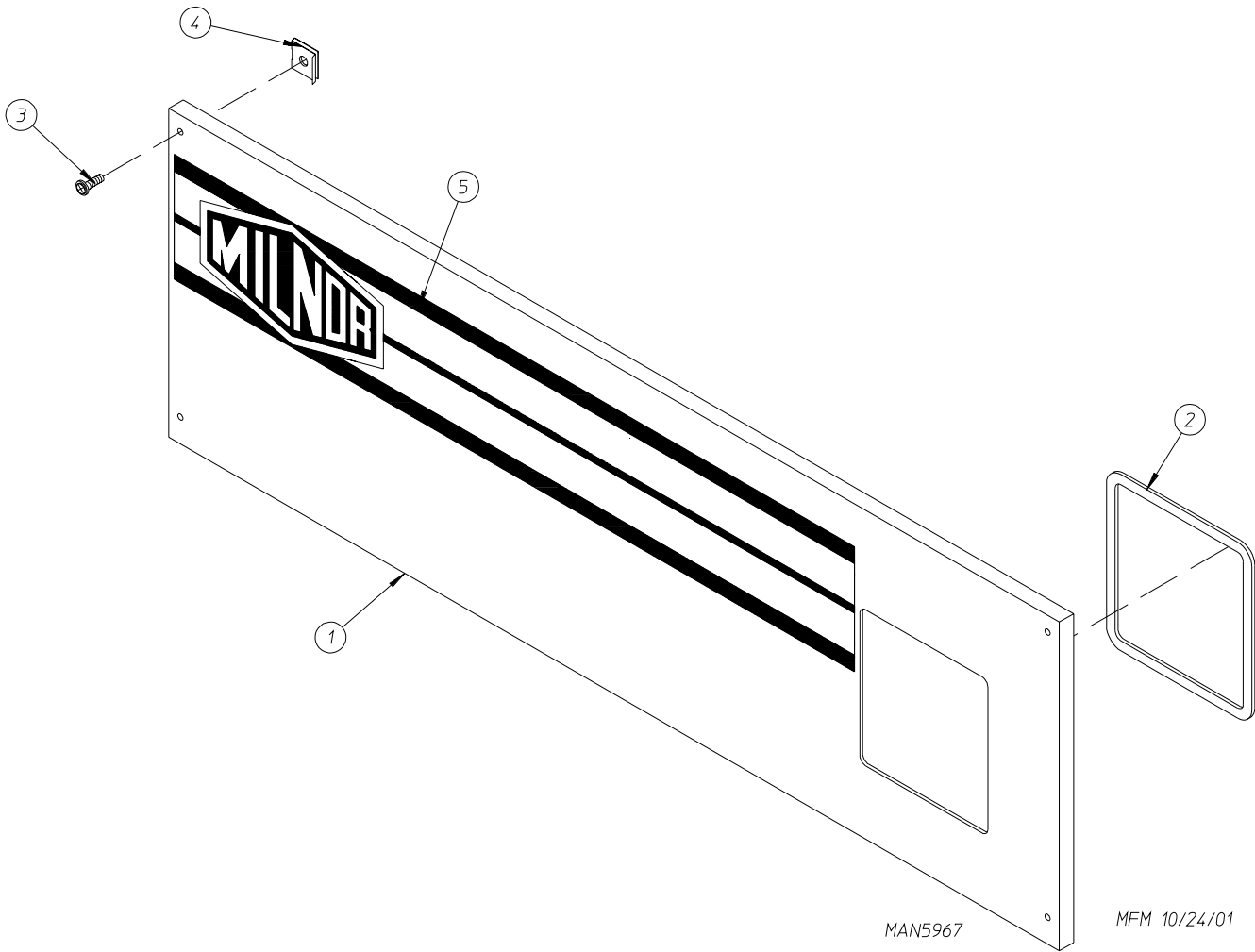

<u>Illus. No.</u>	<u>Part No.</u>	<u>Qty.</u>	<u>Description</u>
1	824254	1	Phase 7 Control Door without Hinge
2	117604	2	Noise Suppression Tape (sold by the foot)
3	150314	4	#10-32 x 1/2" TORX® Screw
	150318	1	TORX PLUS® Bit 1/4" (for removal of TORX® head screw)
4	154011	4	#10-32 Multi-Thread U-Nut
5	112366	1	Milnor Logo

Dual Timer Control Door Assembly

For Models Mfd. prior to July 10, 2002

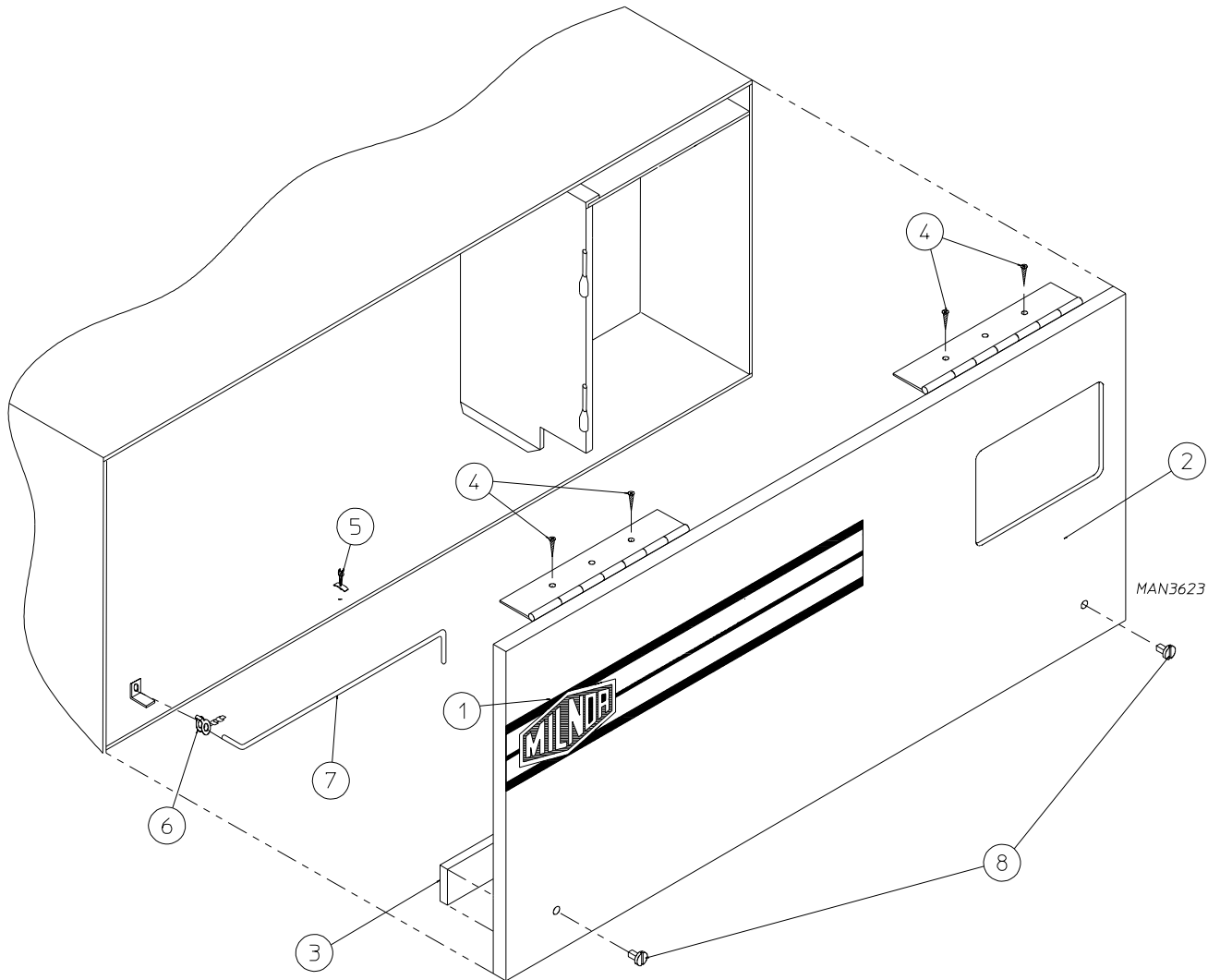

Illus. No.	Part No.	Qty.	Description
1	-----*	1	Logo ONLY
2	883733	1	White Control Door Assembly (includes illus. nos. 2, 3, and 8)
3	117604	4	Noise Suppression Tape (sold by the foot)
4	150309	4	#10-16 x 1/2" Hex Head TEK Crimptite Screw
5	102603	1	Control Door Rod Support Catch
6	102601	1	Control Door Rod Retainer Clip
7	102502	1	Control Door Support Rod
8	882541	2	Spring Turn Latch (2-piece)

* Contact reseller for logo.

Phase 7 Non-Coin Microprocessor Control Panel Assembly

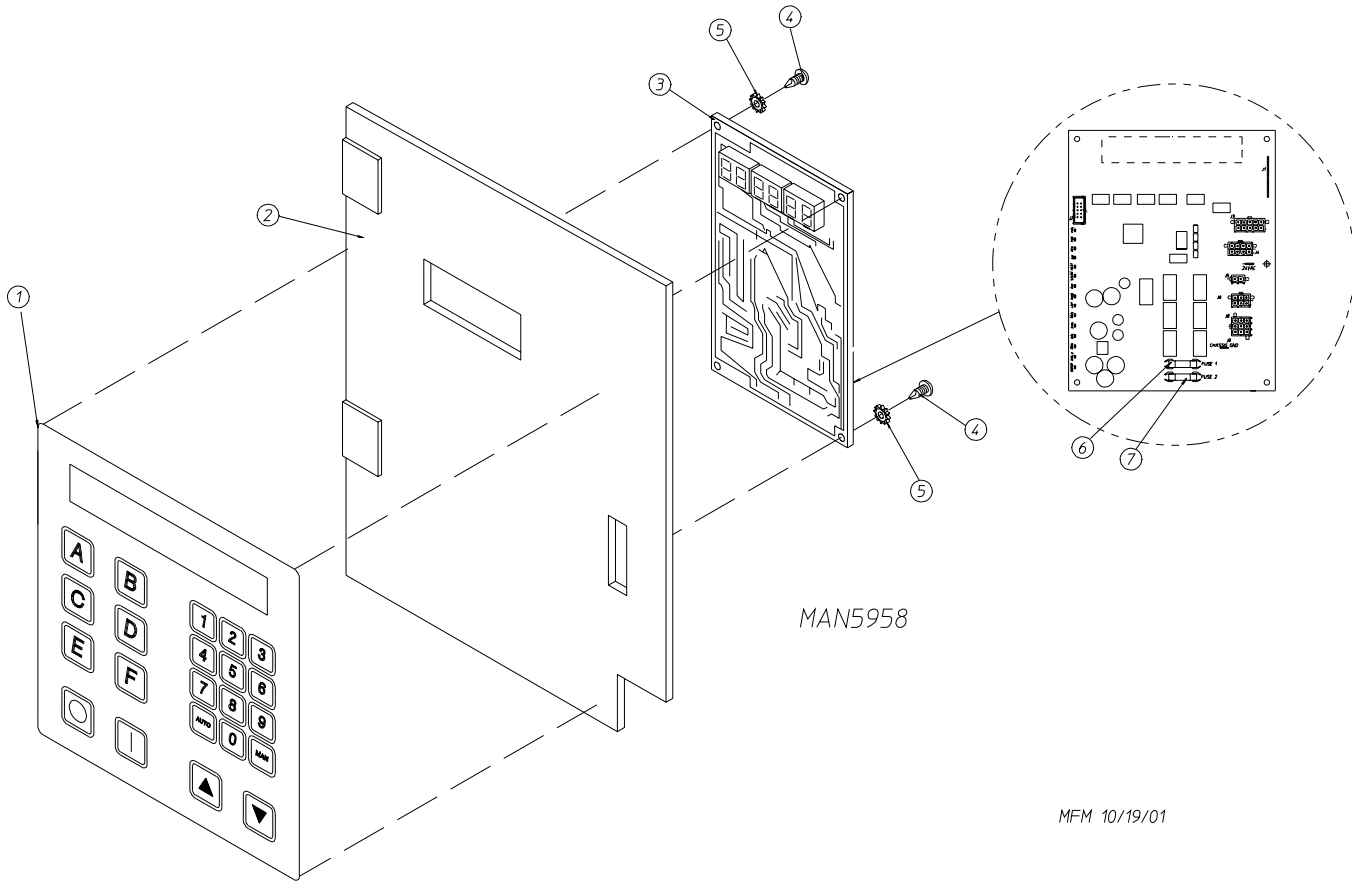

Illus. No.	Part No.	Qty.	Description
1	112577	1	Phase 7 Non-Coin Keypad
2	814902	1	Phase 7 Non-Coin Microprocessor Controller (computer) Panel ONLY (for models mfd. as of May 11, 2011)
	850984	1	Phase 7 Non-Coin Microprocessor Controller (computer) Panel ONLY (for models mfd. prior to May 11, 2011)
3	887004	1	Phase 7.2.2 Board with Fire Suppression System and H ₂ O (pressure) Switch
	887001	1	Phase 7.2.2 Board with Fire Suppression System and no H ₂ O (pressure) Switch
	887024	1	Phase 7.2.2 Board without Fire Suppression System
4	150005	2	#6-32 x 3/4" Phillips Round Head Machine Screw
5	153010	2	#6 Star Washer
6	136097	1	500 mA Fuse
7	136016	1	5-Amp Fuse

Dual Timer with Illuminated Green Start Button

For Models Mfd. as of June 29, 2011

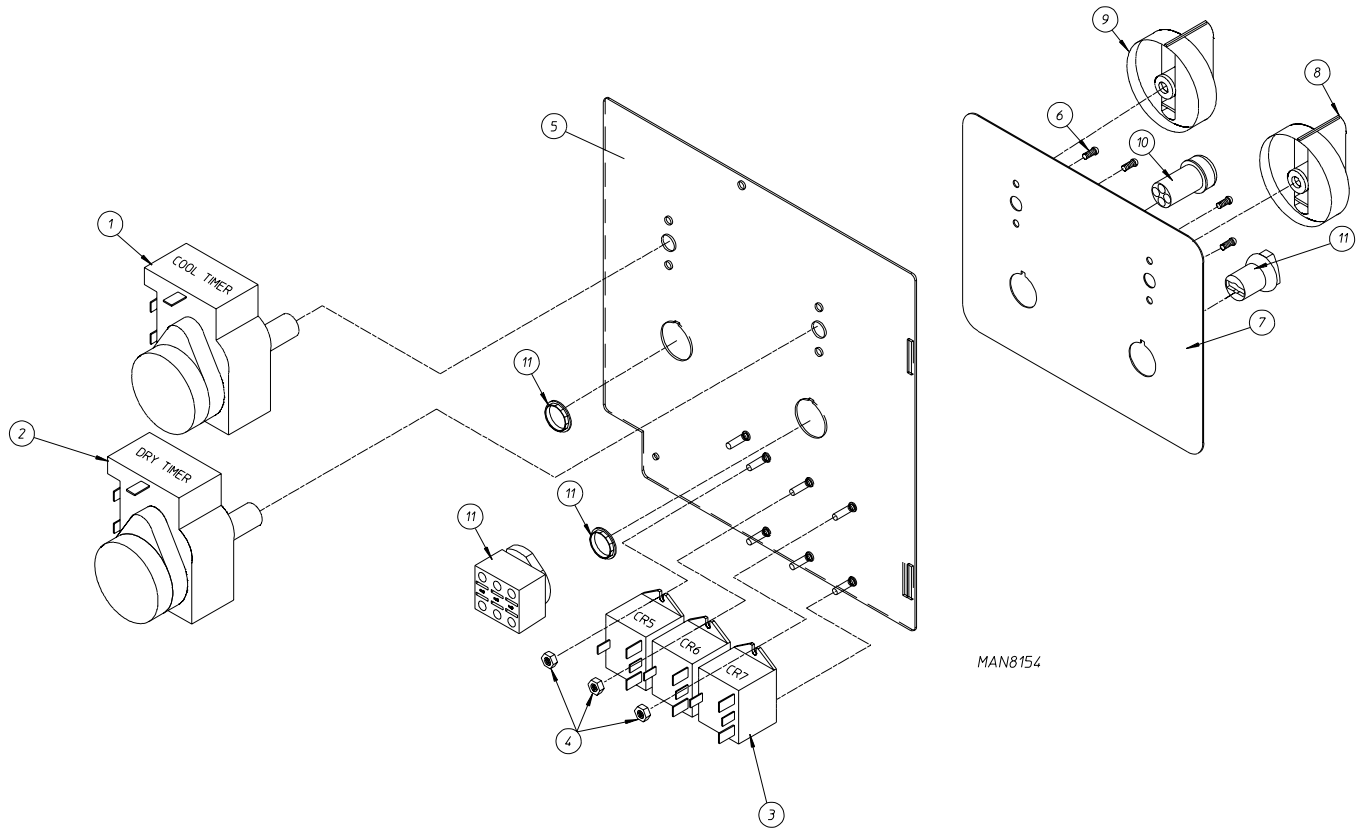

Illus. No.	Part No.	Qty.	Description
1	802837	1	15 Minute Timer with Terminals
2	802838	1	60 Minute Timer with Terminals
3	131406	3	Relay SPDT 24V
4	152013	7	#6-32 Hex Nut
5	802840	1	Main Line Control Panel Assembly (includes illus. nos. 1 through 11)
	802836	1	Main Line Control Panel ONLY
6	150110	4	#8-32 x 1/4" Phillips Machine Screw
7	112558	1	Dual Timer Cover Plate
8	124104	1	Pure Touch Knob with Red Pointer
9	124105	1	Pure Touch Knob with Blue Pointer
10	100299	1	Green Lighted Push Button with N.O.
11	123549	1	3-Position Selector Switch

Dual Timer "Tap Touch" Controls

For Models Mfd. prior to June 29, 2011

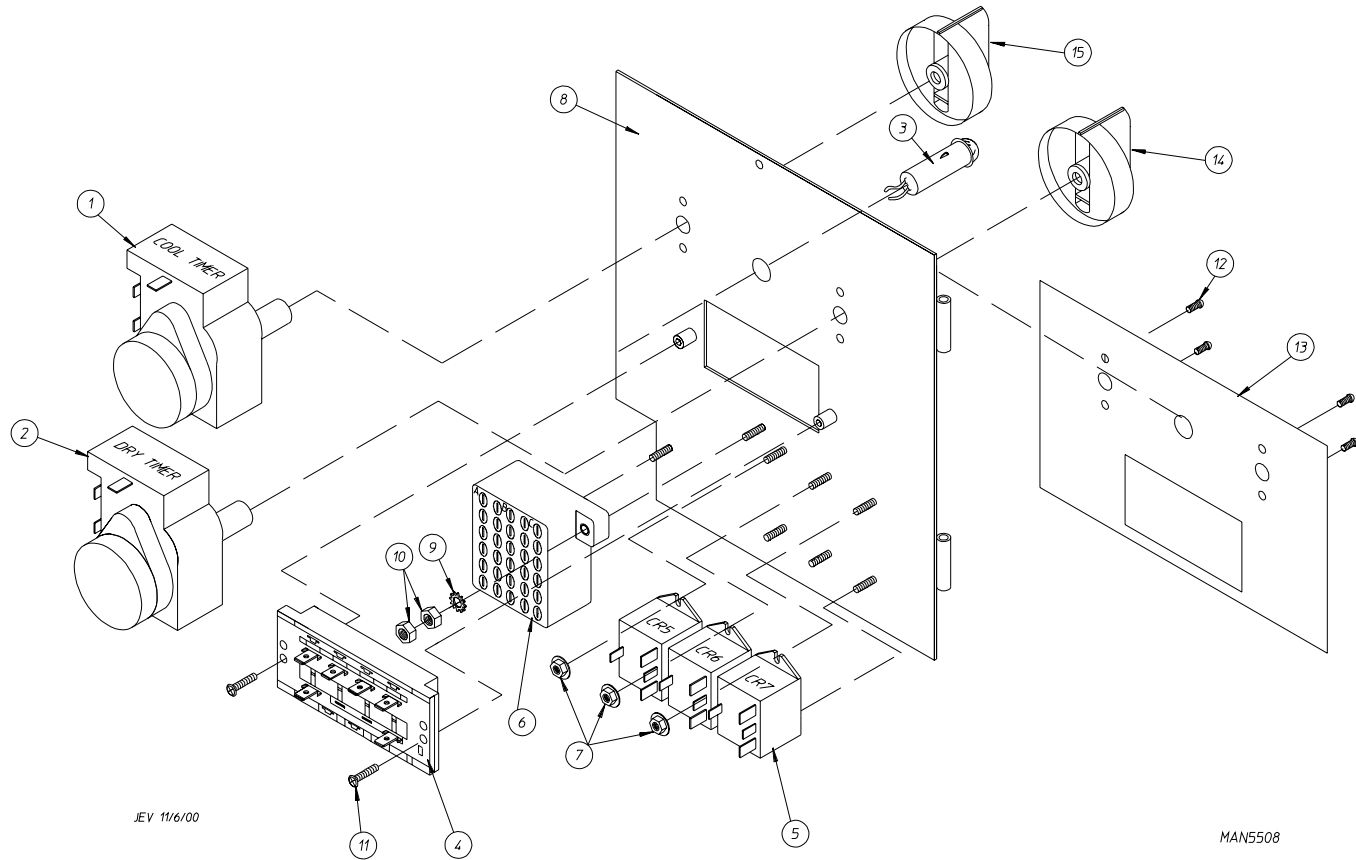

JEV 11/6/00

MAN5508

Illus. No.	Part No.	Qty.	Description
1	124030	1	15 Minute Timer – 24 VAC
2	124025	1	60 Minute Timer – 24 VAC
3	824175	1	Red Pilot Light – 24 VAC
4	122301	1	"Tap Touch" Switch
5	131932	3	Relay SPST 24v
6	120730	1	30-Position Terminal Block
7	151000	6	#6-32 Pal Nut
8	882903	1	Dual Timer Panel Complete (includes illus. nos. 1 through 15)
	850392	—	Dual Timer Panel ONLY
9	153010	2	#6 Star Washer
10	152000	3	#6-32 Hex Nut
11	150207	2	#10-24 x 1/2" Phillips Pan Head Machine Screw
12	150110	4	#8-32 x 1/2" Phillips Round Head Machine Screw
13	112563	1	Dual Timer Panel Overlay
14	124104	1	Pure Touch Knob with Red Pointer
15	124105	1	Pure Touch Knob with Blue Pointer

Phase 7 Non-Coin Microprocessor Control Box Assembly

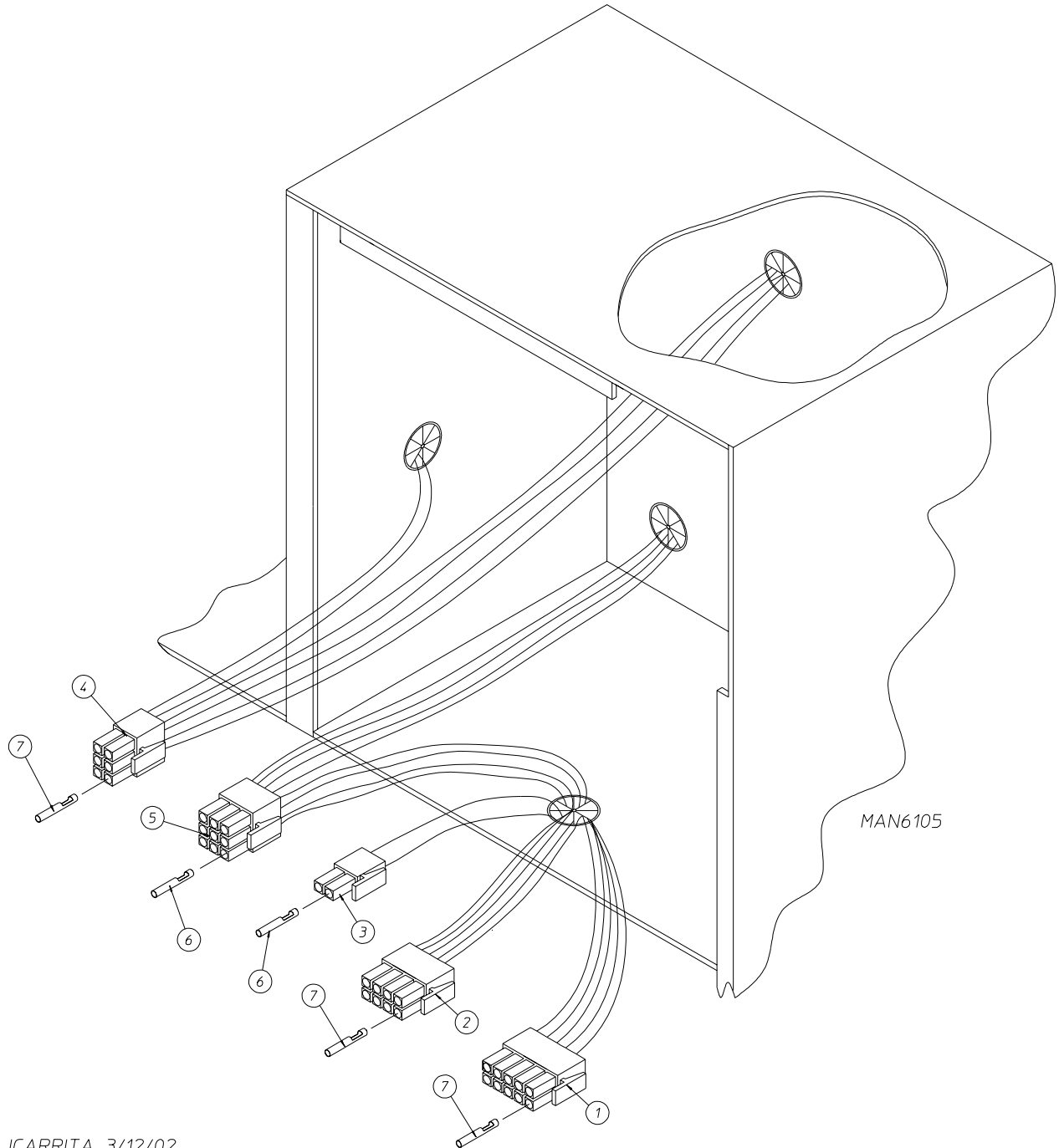

JCARRITA 3/12/02

Illus. No.	Part No.	Qty.	Description
1	122681	1	10-Pin Connector
2	122676	1	8-Pin Connector
3	122646	1	2-Pin Connector
4	122683	1	6-Pin Connector
5	122640	1	9-Pin Connector
6	122706	*	#20-16 Socket
7	122669	*	Female Crimp Terminal

* As needed.

Dual Timer Control Box Assembly

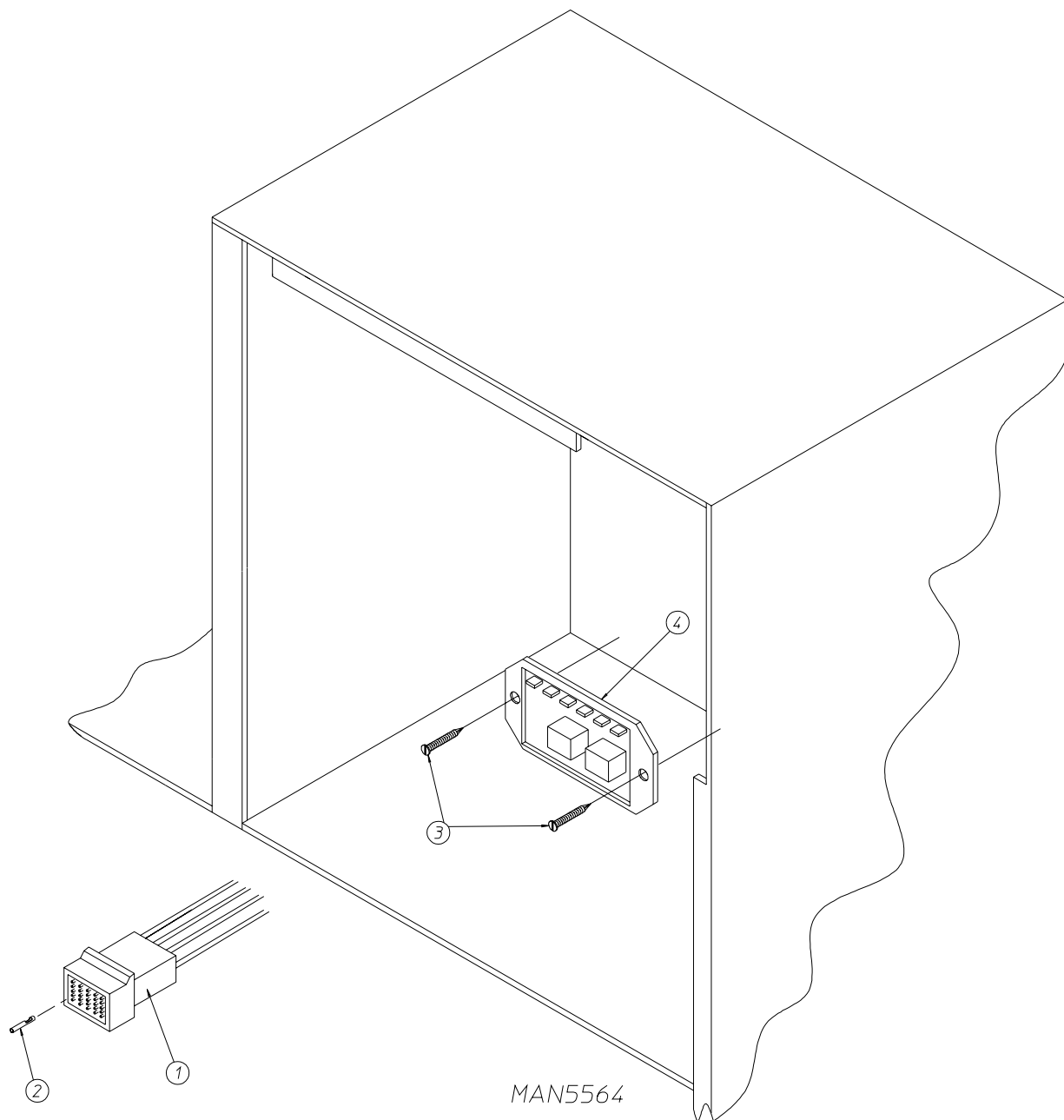

JCARRITA 12/26/00

<u>Illus. No.</u>	<u>Part No.</u>	<u>Qty.</u>	<u>Description</u>
1	122641	1	15-Pin Connector
2	122706	15	Socket Terminal
	122801	1	Pin / Socket Extraction Tool ... Not Illustrated
3	150301	2	#8-18 x 7/16" Phillips Pan Head TEK Screw
4	884252	1	Reversing Timer 24 Volt (for reversing dual timer models Only)

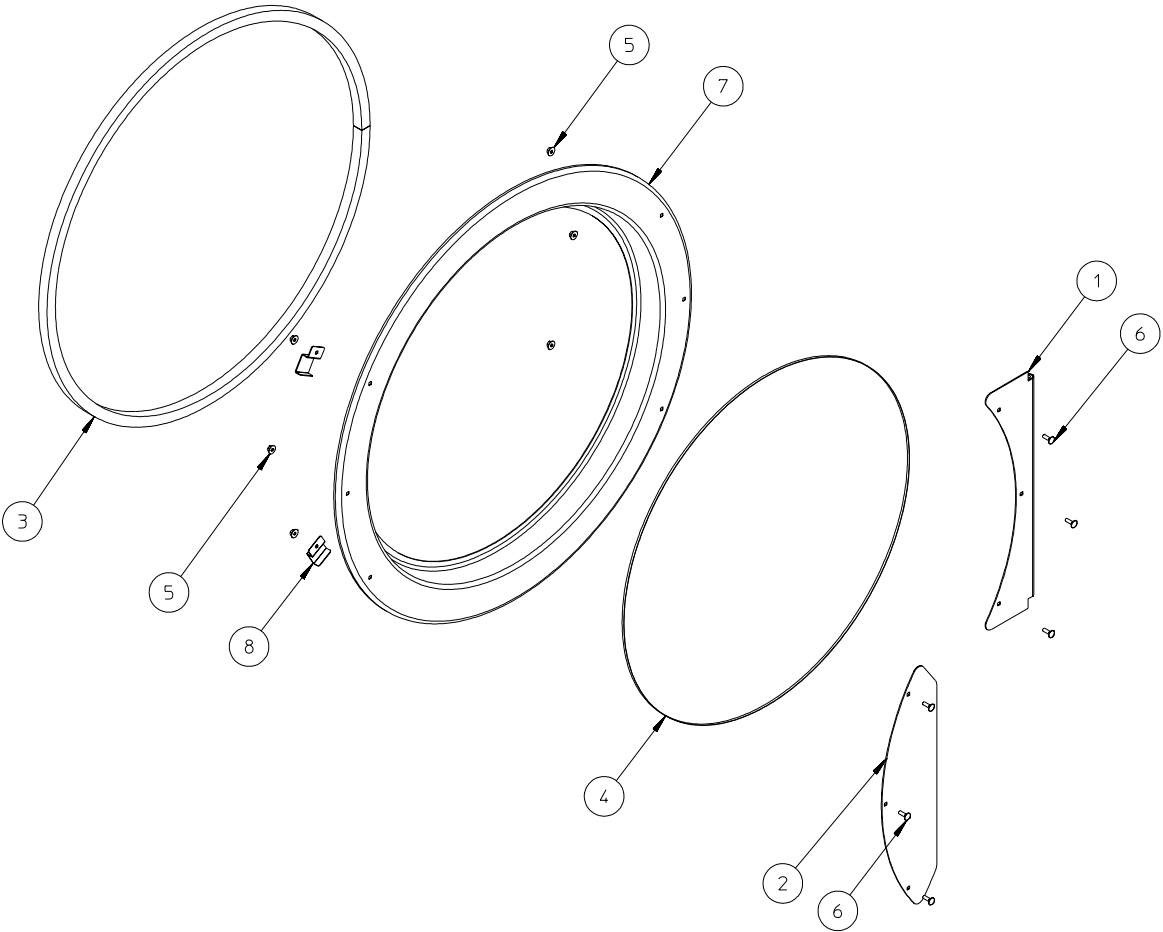

JCARRITA 1/2/08

MAN7532

Illus. No.	Part No.	Qty.	Description
1	835128	1	Main Door Hinge (for models mfd. as of February 18, 2005)
	881685	1	Main Door Hinge (for models mfd. prior to February 18, 2005)
2	314729*	1	Main Door Handle
3	102357	1	Door Gasket
	170731	1	Black Adhesive (10.3 oz. cartridge)
	170730	1	White Adhesive (10.3 oz. cartridge)
4	102221	1	Door Glass
	170731	1	Black Adhesive (10.3 oz. cartridge)
	170730	1	White Adhesive (10.3 oz. cartridge)
5	152014	6	1/4-20 Free Spin Wash Nut
6	150683	6	1/4-20 x 5/8" Carriage Bolt
7	801600	1	Main Door Assembly Complete (for models mfd. as of September 11, 2006)
	835003	1	Main Door Assembly Complete (for models mfd. between February 18, 2005 and September 11, 2006)
	881689	1	Main Door Assembly Complete (for models mfd. prior to February 18, 2005)
8	185522	2	Main Door Magnet Bracket (for models mfd. as of September 11, 2006)

* Specify color when ordering.

Main Door Switch Assembly

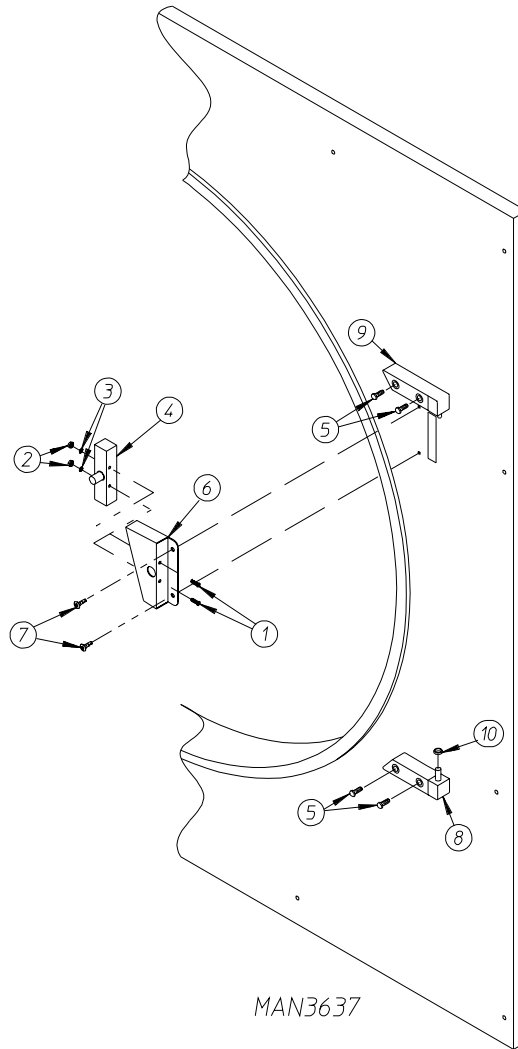

Illus. No.	Part No.	Qty.	Description
1	150006	2	#6-32 x 7/8" Phillips Pan Head Machine Screw
2	152013	2	#6-32 Hex Nut
3	153010	2	#6 Star Washer
4	137005	1	Single-Pole Door Switch
5	150445	4	1/4-20 x 3/4" Cap Screw
6	882866	1	Main Door Switch Housing (black)
	881687	1	Main Door Switch Housing (white)
	883338	1	Main Door Switch with Housing Assembly (black) (includes illus. nos. 1 through 4 and 6)
	881702	1	Main Door Switch with Housing Assembly (white) (includes illus. nos. 1 through 4 and 6)
7	150301	2	#8-18 x 7/16" Phillips Pan Head TEK Screw
8	881151	1	Bottom Hinge Block (black) (includes illus. nos. 5, 8, and 10)
	881441	1	Bottom Hinge Block (white) (includes illus. nos. 5, 8, and 10)
9	881152	1	Top Hinge Block (black) (includes illus. nos. 5 and 9)
	881440	1	Top Hinge Block (white) (includes illus. nos. 5 and 9)
10	153031	1	Nylon Washer

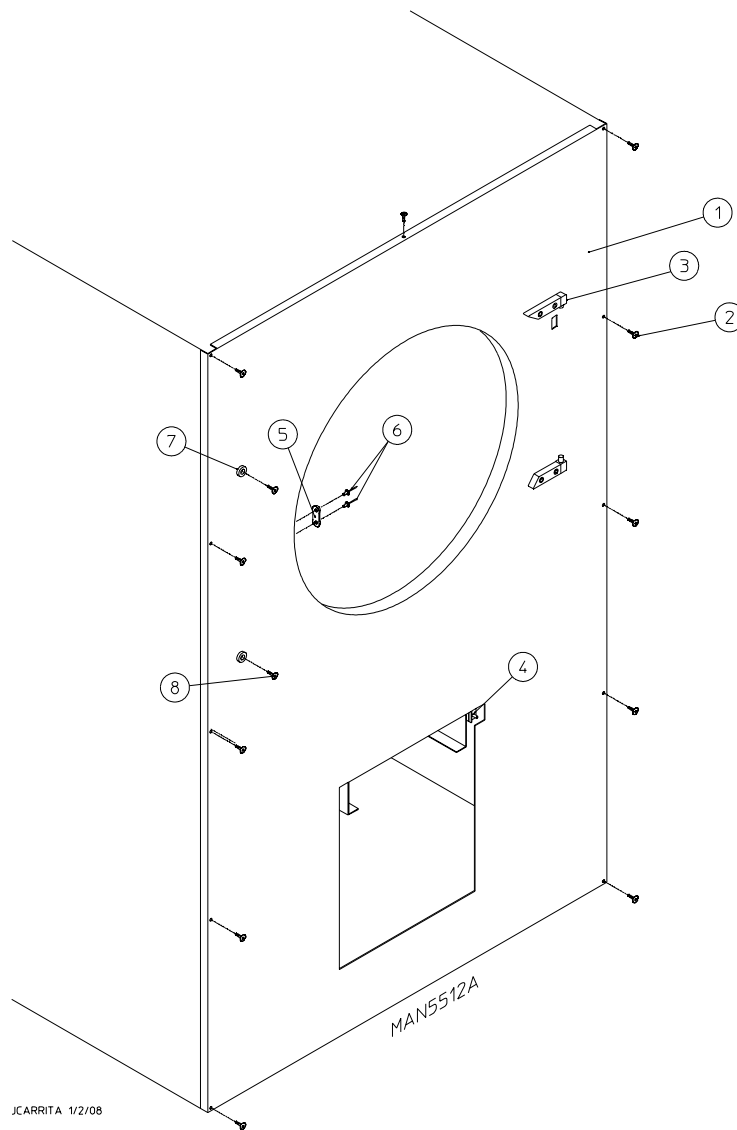

Illus. No.	Part No.	Qty.	Description
1*	801604	1	Front Panel Assembly (for models mfd. as of September 11, 2006) (includes illus. nos. 1, 7, and 8)
	883703	1	Front Panel Assembly (for models mfd. prior to September 11, 2006) (includes illus. nos. 1, 5, and 6)
2	150313	11	#10-16 x 1/2" TORX PLUS®
	150318	1	25 IP TORX PLUS® Bit 1/4 Hex (for removal of TORX® head screw)
3	—	1	Main Door Hinge Block Assembly (refer to Main Door Switch Assembly on page 14)
4	—	1	Lint Drawer Switch (refer to Lint Drawer / Lint Drawer Switch Assembly on page 16)
5	881987	1	Friction Door Latch Kit (includes illus. nos. 5 and 6)
6	154215	2	5/32" Pop Rivet
7	102004	2	0.750 Round Door Magnet
8	152223	2	1/2" TORX® Head Screw

* Specify color when ordering.

Lint Drawer / Lint Drawer Switch Assembly

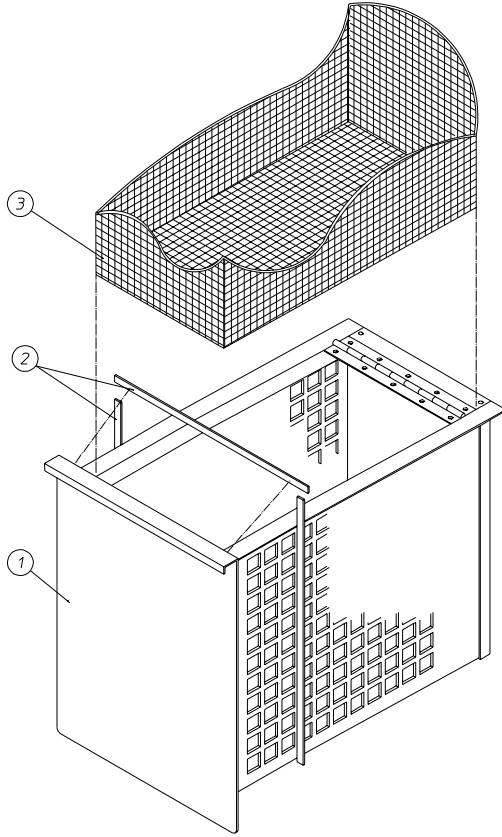

LINT DRAWER

MAN6473

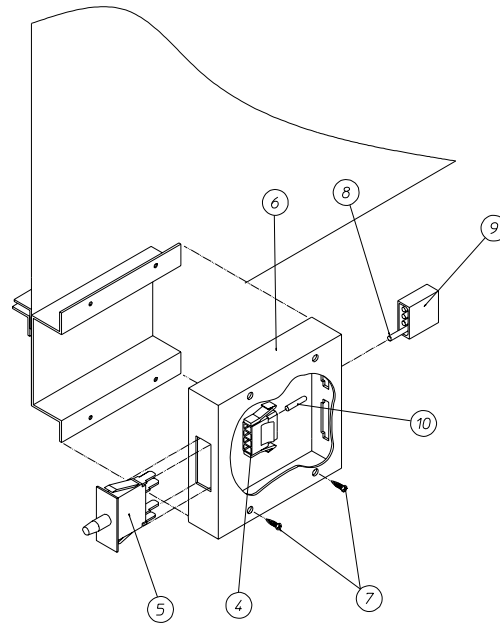

LINT DRAWER SWITCH ASSY

JCARRITA 1/20/03

Illus. No.	Part No.	Qty.	Description
1	884055	1	White Lint Drawer Assembly (includes illus. nos. 1 and 2)
	884056	1	Coral Blue Lint Drawer Assembly (includes illus. nos. 1 and 2)
	884057	1	Ivory Lint Drawer Assembly (includes illus. nos. 1 and 2)
	884149		White Lock Lint Drawer with Bag
	884150		Blue Lock Lint Drawer with Bag
	884151		Ivory Lock Lint Drawer with Bag
2	117605	5	Neoprene Sponge Tape (sold by the foot)
3	108222	1	Lint Screen Assembly
4	122605	*	4-Pin Connector (female)
5	122116	1	Lint Drawer Switch
6	833123	1	Lint Drawer Switch Box Assembly (for micro models Only) (includes illus. nos. 4 through 6 and 10)
	818087	1	Lint Drawer Switch Box Assembly (for dual timer models Only) (includes illus. nos. 4 through 6 and 10)
	304136	1	Lint Drawer Switch Box Cover ONLY
7	150301	2	#8-18 x 7/16" Phillips Pan Head TEK Screw
8	122700	*	Pin Terminal ONLY
9	122604	*	4-Pin Connector (male)
10	122701	*	Socket Terminal ONLY
	122801	1	Pin / Socket Extraction Tool ... Not Illustrated

* As needed.

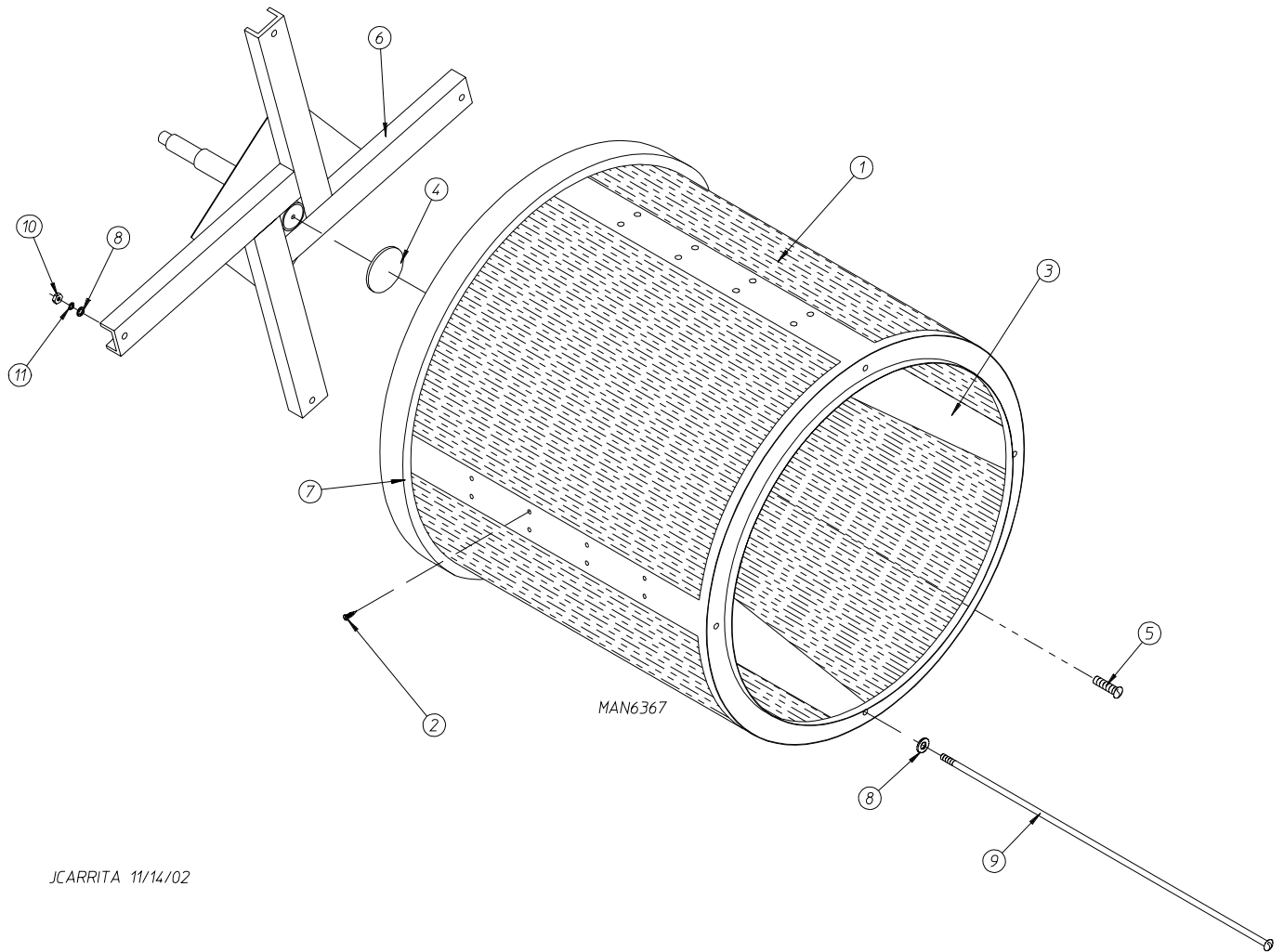

Illus. No.	Part No.	Qty.	Description
1	881780	1	Tumbler ONLY
	859305	1	1-3/4" Tumbler / Support Assembly Complete (includes illus. nos. 1 through 6 and 8 through 11)
2	150313	40	#10-16 x 1/2" TORX® Head Crimptite Screw
	150318	1	TORX PLUS® Bit 1/4" Hex (for removal of TORX® head screw)
3	390074	4	Tumbler Rib
4	115986	1	Felt Tumbler Pad (for models mfd. as of January 22, 2002)
5	150518	1	5/16-18 x 3/4" Socket Button Head Screw (for models mfd. prior to January 22, 2002)
6	800613	1	Tumbler Support
7	116000	1	Felt Collar
	401010	1	#847 Adhesive for Felt Collar (5 oz. tube)
8	153004	8	3/8" Flat Washer
9	100905	4	3/8-16 x 37" Tie Rod
10	152027	4	3/8-16 Hex Nut
11	153005	4	3/8" Lock Washer

Tumbler Bearing Assembly

For Models with Setscrew Type Bearings

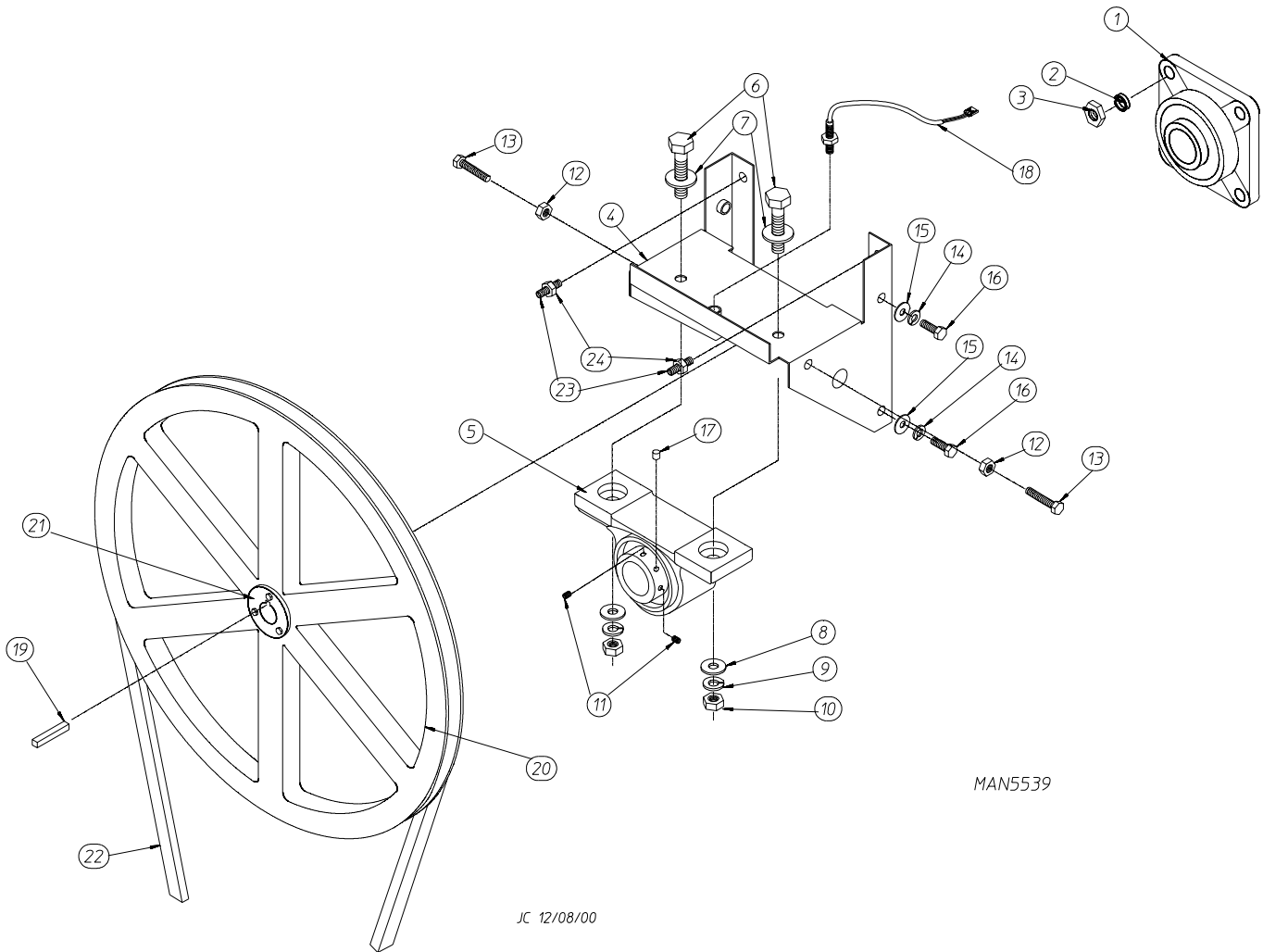

Tumbler Bearing Assembly

For Models with Setscrew Type Bearings

<u>Illus. No.</u>	<u>Part No.</u>	<u>Qty.</u>	<u>Description</u>
1	880220	1	1-3/4" Flange Bearing
2	153025	4	9/16" Lock Washer
3	152050	4	9/16-12 Hex Nut
4	883387	1	Pillow Block Bearing Assembly Complete (for microprocessor models Only) (includes illus. nos. 4 through 18, 23, and 24)
	882544	1	Pillow Block Bearing Assembly Complete (for dual timer models Only) (includes illus. nos. 4 through 17, 23, and 24)
	882543	1	Pillow Block Bearing Platform ONLY (for microprocessor models Only)
	882542	1	Pillow Block Bearing Platform ONLY (for dual timer models Only)
5	880202	1	1-3/8" Pillow Block Bearing (for dual timer models Only)
	880779	1	1-3/8" Pillow Block Bearing (for microprocessor models Only)
6	150601	2	3/8-16 x 2" Hex Bolt
7	153004	2	3/8" Flat Washer
8	153004	2	3/8" Flat Washer
9	153005	2	3/8" Lock Washer
10	152005	2	3/8-16 Hex Nut
11	154326	2	5/16-24 x 3/8" Setscrew
12	152004	2	5/16-18 Hex Nut
13	150621	2	5/16-18 x 1-1/2" Tap Bolt
14	153002	4	5/16" Lock Washer
15	153004	6	3/8" Flat Washer
16	150501	4	5/16-18 x 3/4" Tap Bolt
17	102120	1	Sintered 8 Magnet (for microprocessor models Only)
18	883386	1	Rotational Sensor Assembly (for microprocessor models Only)
19	100735	1	Shaft Key (for reversing models Only)
	100724	1	Shaft Key (for non-reversing models Only)
20	884042	1	18" Pulley (for non-reversing models Only)
	101252	1	18" Pulley (for reversing models mfd. as of June 16, 2009)
	101118	1	18-3/4" Pulley (for reversing models mfd prior to June 16, 2009)
21	101110	1	1" Taper Lock Bushing (for reversing models Only)
22	100108	1	5L-680 V-Belt (for non-reversing models and reversing models mfd. prior to June 16, 2009)
	100107	1	5L-670 V-Belt (for reversing models mfd. as of June 16, 2009)
23	150610	2	5/16-18 x 1-1/2" Allen Setscrew
24	152004	2	5/16-18 Hex Nut

Tumbler Bearing Assembly

For Models with Grip Lock Type Bearings

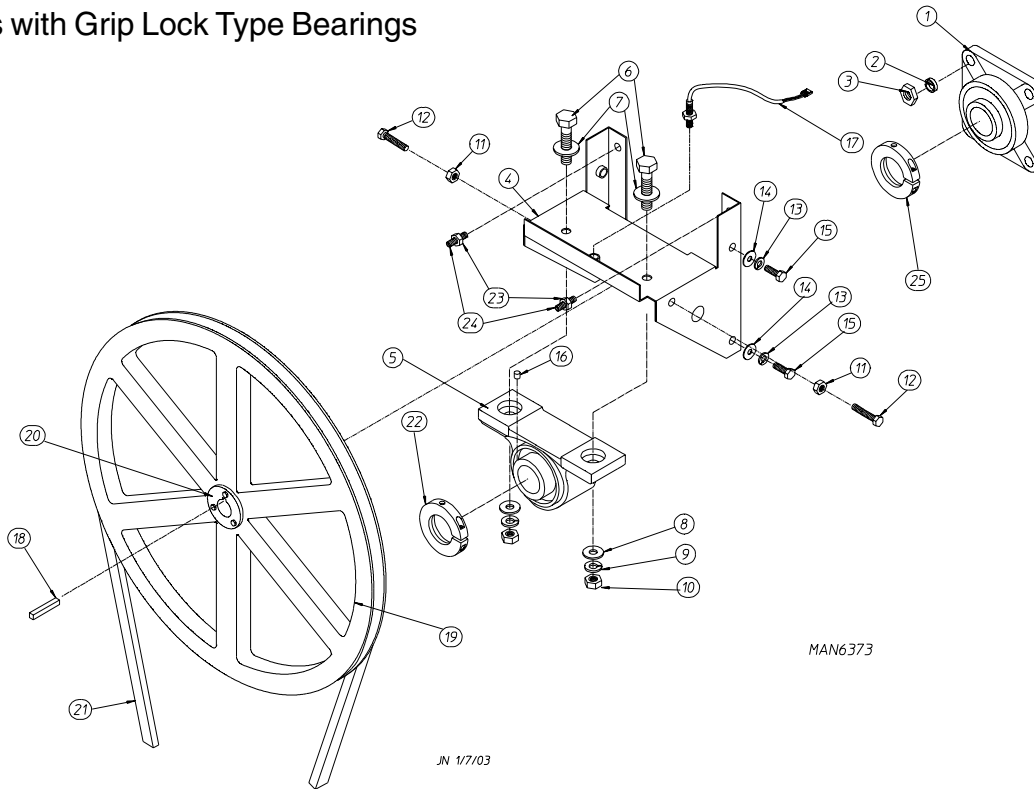

Illus. No.	Part No.	Qty.	Description
1	883735	1	1-3/4" Flange Bearing
2	153025	4	9/16" Lock Washer
3	152050	4	9/16-12 Hex Nut
4	883736	1	Pillow Block Bearing Assembly Complete (for microprocessor models Only) (includes illus. nos. 4 through 18, 23, and 24)
	883734	1	Pillow Block Bearing Assembly Complete (for dual timer models Only) (includes illus. nos. 4 through 17, 23, and 24)
	882543	1	Pillow Block Bearing Platform ONLY (for microprocessor models Only)
	882542	1	Pillow Block Bearing Platform ONLY (for dual timer models Only)
5	883710	1	1-3/8" Pillow Block Bearing (for microprocessor models Only)
	883737	1	1-3/8" Pillow Block Bearing (for dual timer models Only)
6	150601	2	3/8-16 x 2" Hex Bolt
7	153004	2	3/8" Flat Washer
8	153004	2	3/8" Flat Washer
9	153005	2	3/8" Lock Washer
10	152005	2	3/8-16 Hex Nut
11	152004	2	5/16-18 Hex Nut
12	150621	2	5/16-18 x 1-1/2" Tap Bolt
13	153002	4	5/16" Lock Washer
14	153004	6	3/8" Flat Washer
15	150501	4	5/16-18 x 3/4" Tap Bolt
16	102120	1	Sintered 8 Magnet (for microprocessor models Only)
17	883386	1	Rotational Sensor Assembly (for microprocessor models Only)
18	100735	1	Shaft Key (for reversing models Only)
19	884042	1	18" Pulley (for non-reversing models Only)
	101118	1	18-3/4" Pulley (for reversing models Only)
20	101110	1	1" Taper Lock Bushing (for reversing models Only)
21	100108	1	5L-680 V-Belt (tumbler to idler)
22	100270	1	Grip Lock Collar (1-3/8")
23	150610	2	5/16-18 x 1-1/2" Allen Setscrew
24	152004	2	5/16-18 Hex Nut
25	100272	1	Grip Lock Collar (1-3/4")

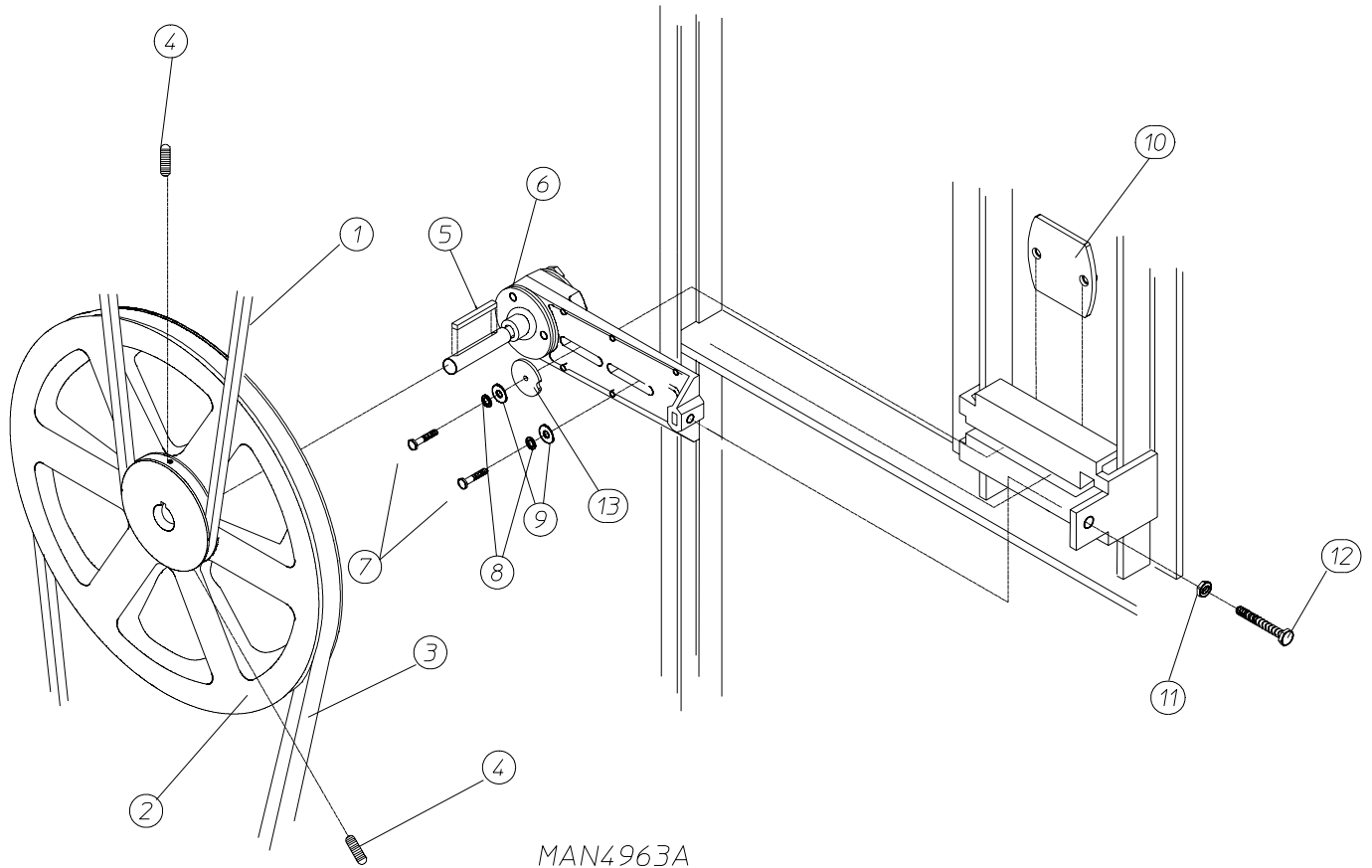

Illus. No.	Part No.	Qty.	Description
1	100108	1	5L-680 V-Belt (for non-reversing models and reversing models mfd. prior to June 16, 2009)
	100107	1	5L-670 V-Belt (for reversing models mfd. as of June 16, 2009)
2	101140	1	14" x 3" Compound Pulley
3	100194	1	4L-720 V-Belt (idler to motor) for Non-Reversing Models ONLY
	100109	1	4L-650 V-Belt (idler to motor) for Reversing Models ONLY
4	154301	2	5/16-18 x 1" Allen Setscrew
5	100705	1	3/16" x 3/16" x 1-3/8" Key
6	882576	1	Idler Bearing Assembly Complete (includes illus. nos. 5 through 12)
7	150600	2	3/8-16 x 1-1/2" Hex Head Machine Bolt
8	153005	2	3/8" Lock Washer
9	153004	2	3/8" Flat Washer
10	884384	1	Idler Square Washer
11	152004	1	5/16-18 Hex Nut
12	150509	1	5/16-18 x 3" Hex Head Machine Bolt
13	315445	1	Heavy Duty Idler Washer

Non-Reversing Motor Mount Assembly

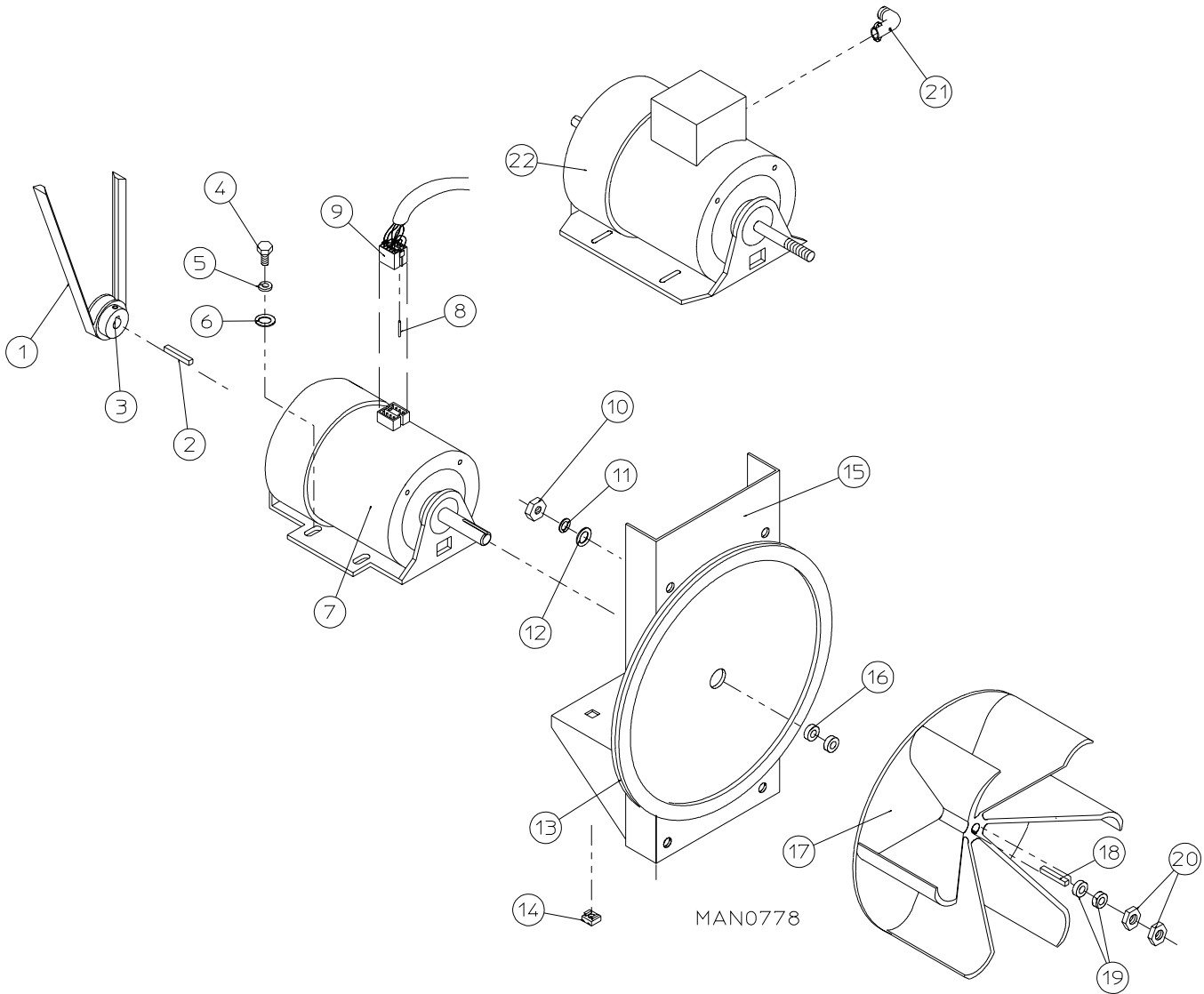

Illus. No.	Part No.	Qty.	Description
1	100194	1	4L-720 V-Belt (idler to motor)
2	100701	1	3/16" x 3/16" x 1" Key
3	101130	1	5/8" x 2-1/2" Motor Pulley (60 Hz Only) (for models mfd. as of September 11, 2006)
	101139	1	5/8" x 2-3/4" Motor Pulley (50 Hz Only) (for models mfd. as of September 11, 2006)
	101133	1	5/8" x 2-1/4" Motor Pulley (60 Hz Only) (for models mfd. prior to September 11, 2006)
	101130	1	5/8" x 2-1/2" Motor Pulley (50 Hz Only) (for models mfd. prior to September 11, 2006)
4	150501	4	5/16-18 x 3/4" Tap Bolt
5	153002	4	5/16" Lock Washer

Non-Reversing Motor Mount Assembly

<u>Illus. No.</u>	<u>Part No.</u>	<u>Qty.</u>	<u>Description</u>
6	153001	4	5/16" Flat Washer
7	100073	1	1 hp 120/208/230v (1ø) 60 Hz Motor with Plug (56Z frame)
	181050	1	1 hp 200-240v (1ø) 50 Hz Motor with Plug
8	122701	8	Socket Terminal ONLY
	122801	1	Pin / Socket Extraction Tool ... Not Illustrated
9	137030	1	8-Pin Housing Connector
10	152004	4	5/16-18 Hex Nut
11	153002	4	5/16" Lock Washer
12	153001	4	5/16" Flat Washer
13	117604	4	Noise Suppression Tape (sold by the foot)
14	154000	4	5/16-18 Tinnerman Nut
15	803561	1	Non-Reversing Motor Mount ONLY (56Z frame)
	803876	1	1 hp 120/230v (1ø) 60 Hz Motor Mount Assembly with Plug Complete (for models mfd. as of September 11, 2006) (includes illus. nos. 2 through 7 and 13 through 20)
	823212	1	1 hp 200-240v (1ø) 50 Hz Non-Reversing Motor Mount Assembly Complete (for models mfd. as of September 11, 2006) (includes illus. nos. 2 through 7 and 13 through 20)
	803877*	1	1 hp 200-460v (3ø) 60 Hz Non-Reversing Motor Mount Assembly Complete (for models mfd. as of September 11, 2006) (includes illus. nos. 2 through 6 and 13 through 22)
	803879*	1	1 hp 200-416v (3ø) 50 Hz Non-Reversing Motor Mount Assembly Complete (for models mfd. as of September 11, 2006) (includes illus. nos. 2 through 6 and 13 through 22)
	803945*	1	1 hp 120/230v (1ø) 60 Hz Motor Mount Assembly with Plug Complete (for models mfd. prior to September 11, 2006) (includes illus. nos. 2 through 7 and 13 through 20)
	801824	1	1 hp 200-240v (1ø) 50 Hz Non-Reversing Motor Mount Assembly Complete (for models mfd. prior to September 11, 2006) (includes illus. nos. 2 through 7 and 13 through 20)
	803955*	1	1 hp 200-460v (3ø) 60 Hz Non-Reversing Motor Mount Assembly Complete (for models mfd. prior to September 11, 2006) (includes illus. nos. 2 through 6 and 13 through 22)
	803958*	1	1 hp 200-416v (3ø) 50 Hz Non-Reversing Motor Mount Assembly Complete (for models mfd. prior to September 11, 2006) (includes illus. nos. 2 through 6 and 13 through 22)
16	153051	1	3/4" Flat Washer
17	882670	1	16" Impellor with 3/4" Bore
18	100714	1	3/16" x 3/16" x 1-7/8" Key
19	153050	2	1/2" Flat Washer
20	152006	2	1/2-20 Left-Hand Jam Nut
21	120200	1	3/8" x 90° Connector
22	100075*	1	1 hp 208/230/460v (3ø) 50/60 Hz Motor

* Specify voltage when ordering.

Reversing Motor Mount Assembly

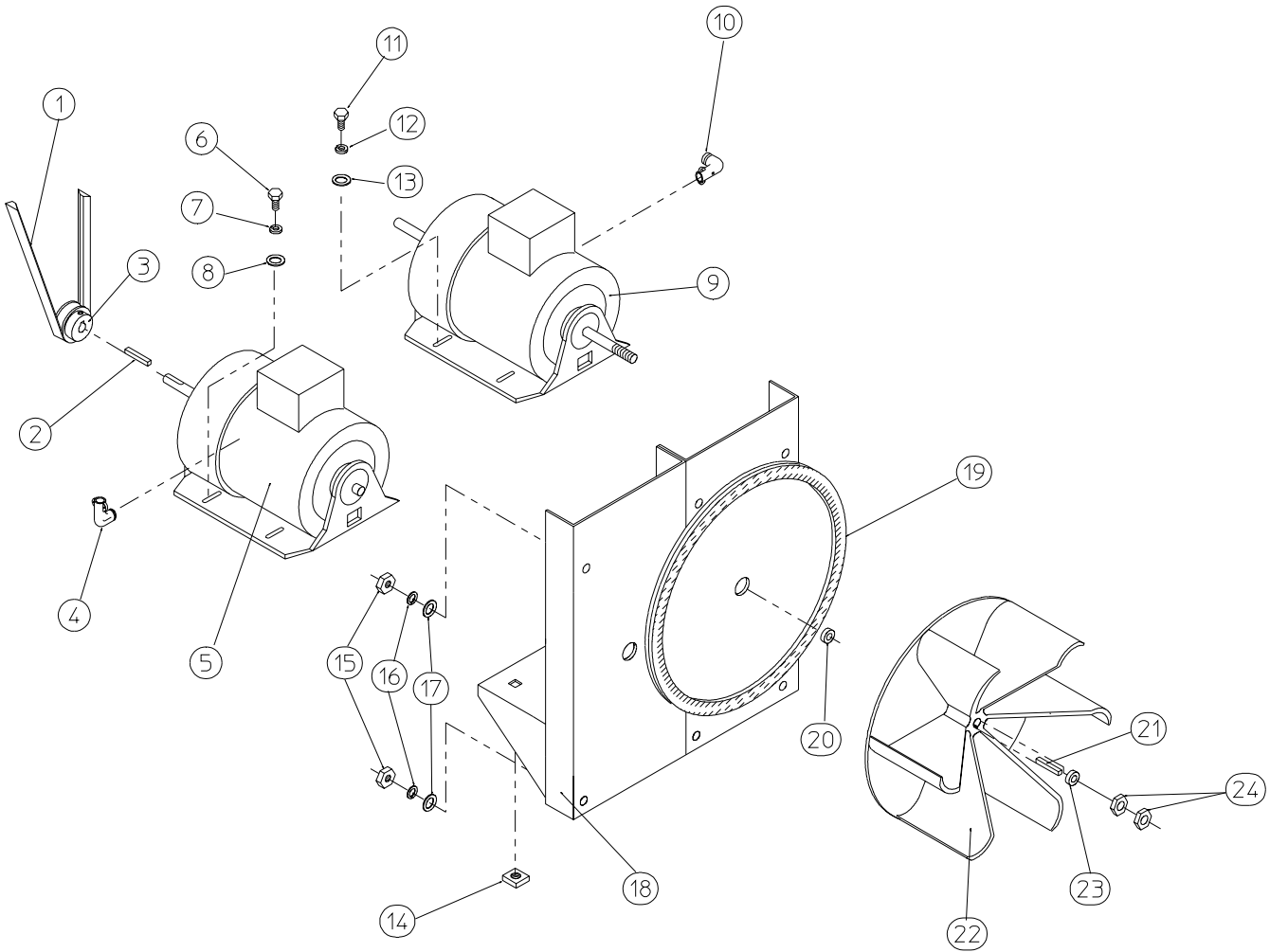

MAN0250

<u>Illus. No.</u>	<u>Part No.</u>	<u>Qty.</u>	<u>Description</u>
1	100109	1	4L-650 V-Belt (to idler assembly)
2	100701	1	3/16" x 3/16" x 1" Key
3	101130	1	5/8" x 2-1/2" Motor Pulley (60 Hz Only) (for models mfd. as of September 11, 2006)
	101139	1	5/8" x 2-3/4" Motor Pulley (50 Hz Only) (for models mfd. as of September 11, 2006)
	101133	1	5/8" x 2-1/4" Motor Pulley (60 Hz Only) (for models mfd. prior to September 11, 2006)
	101130	1	5/8" x 2-1/2" Motor Pulley (50 Hz Only) (for models mfd. prior to September 11, 2006)
4	120200	1	3/8" x 90° Connector
5	181003	1	1/2 hp 208/230/380/460v (3ø) 50/60 Hz Motor (56Z frame)
6	150501	4	5/16-18 x 3/4" Tap Bolt
7	153002	4	5/16" Lock Washer
8	153001	4	5/16" Flat Washer
9	100075	1	1 hp 200/230/460v (3ø) 60 Hz 380v-415v (3ø) 50 Hz Motor with 3/4" Shaft (56Z frame)
10	120200	1	3/8" x 90° Connector
11	150501	4	5/16-18 x 3/4" Tap Bolt
12	153002	4	5/16" Lock Washer
13	153001	4	5/16" Flat Washer
14	154000	8	5/16-18 Tinnerman Nut
15	152004	6	5/16-18 Hex Nut
16	153002	6	5/16" Lock Washer
17	153001	6	5/16" Flat Washer
18	803566	1	Reversing Motor Mount ONLY (56Z frame)
	803882*	1	60 Hz Reversing Motor Mount ONLY (56Z frame) (for models mfd. as of September 11, 2006) (includes illus. nos. 2 through 14 and 18 through 24)
	803879*	1	50 Hz Reversing Motor Mount ONLY (56Z frame) (for models mfd. as of September 11, 2006) (includes illus. nos. 2 through 14 and 18 through 24)
	804029*	1	60 Hz Reversing Motor Mount Assembly Complete (includes illus. nos. 2 through 14 and 18 through 24)
	804030*	1	50 Hz Reversing Motor Mount Assembly Complete (includes illus. nos. 2 through 14 and 18 through 24)
19	117604	5	Noise Suppression Tape (sold by the foot)
20	153051	1	3/4" Flat Washer
21	100714	1	3/16" x 3/16" x 1-7/8" Key
22	882670	1	16" Impellor with 3/4" Bore
23	153050	**	1/2" Flat Washer
24	152006	2	1/2-20 Left-Hand Jam Nut

* Specify voltage when ordering.

** As required.

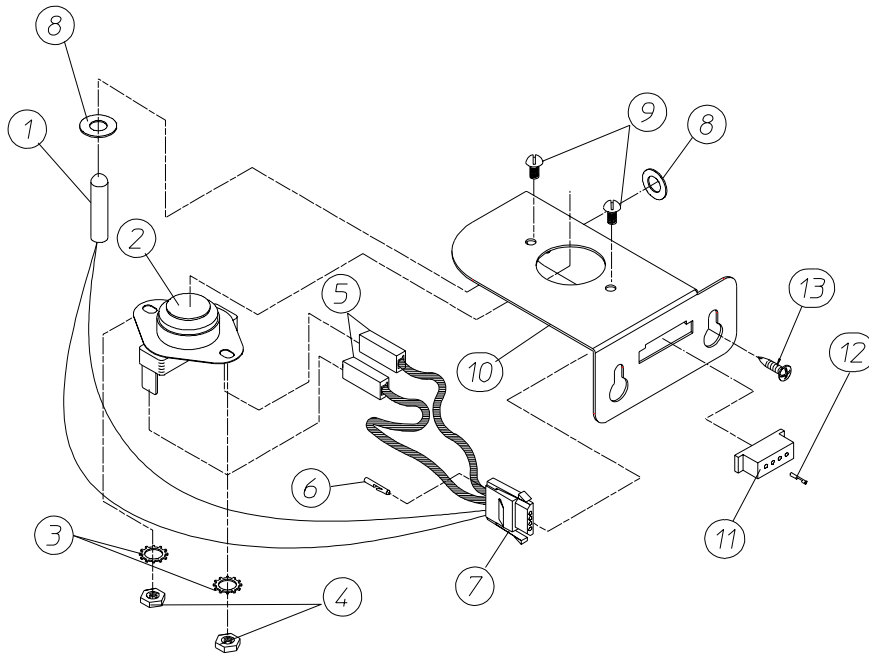

MICROPROCESSOR SENSOR BRACKET ASSEMBLY

MAN6453

JNERY 1/23/03

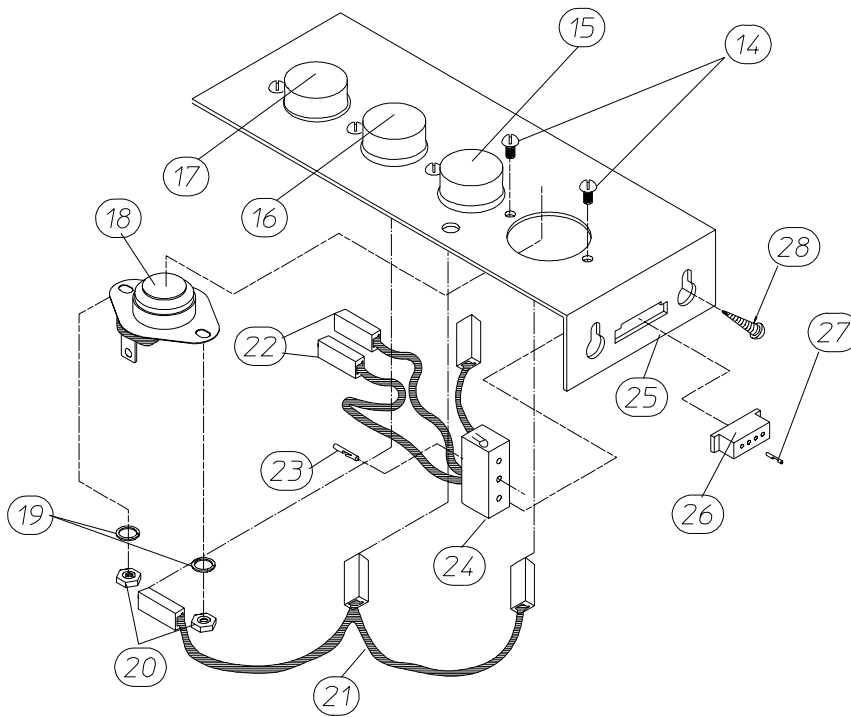

NON-COMPUTER SENSOR BRACKET ASSEMBLY

<u>Illus. No.</u>	<u>Part No.</u>	<u>Qty.</u>	<u>Description</u>
1	880251	1	1/4" Temperature Sensor Probe Assembly (includes illus. nos. 1 through 4)
2	130103	1	225° Hi-Limit Thermostat
3	153010	2	#6 Star Washer
4	152000	2	#6-32 Hex Nut
5	121028	2	Insulated Terminal
6	122701	4	Socket Terminal
	122801	1	Pin / Socket Extraction Tool ... Not Illustrated
7	122605	1	4-Pin Connector (female)
8	154007	2	1/4" Push-On Fastener
9	150005	2	#6-32 x 1/4" Round Head Machine Screw
10	817046	1	Microprocessor Sensor Bracket Assembly Complete (includes illus. nos. 1 through 10)
	322214	1	Microprocessor Sensor Bracket ONLY
11	122604	1	4-Pin Connector (male)
12	122700	4	Pin Terminal
13	150301	2	#8-18 x 7/16" Phillips Pan Head TEK Screw
14	150005	*	#6-32 x 1/4" Phillips Round Head Machine Screw
15	130111	1	130° Thermostat
16	130100	1	150° Thermostat
17	130103	1	225° Hi-Limit Thermostat
18	130101	1	180° Thermostat
19	153010	*	#6 Star Washer
20	152000	*	#6-32 Hex Nut
21	840065	1	Sensor Jumper
22	121028	*	Insulated Terminal
23	122701	*	Socket Terminal
24	122605	1	4-Pin Connector ONLY (female)
	818007	1	Sensor Bracket Harness Assembly (includes illus. nos. 21 through 24)
25	818034	1	Noncomputer Sensor Bracket Assembly Complete (includes thermostats) (includes illus. nos. 14 through 25)
	322062	1	Universal Sensor Bracket ONLY
26	122604	1	4-Pin Connector (male)
27	122700	*	Pin Terminal
	122801	1	Pin / Socket Extraction Tool ... Not Illustrated
28	150301	2	#8-18 x 7/16" Phillips Pan Head TEK Screw

* As required.

Direct Spark Ignition Burner Assembly

<u>Illus. No.</u>	<u>Part No.</u>	<u>Qty.</u>	<u>Description</u>
1*	817086	1	Natural Gas Burner Assembly Complete (includes illus. nos. 1 through 31)
	817137	1	Propane Gas Burner Assembly Complete (includes illus. nos. 1 through 31)
	810047	1	Burner Box ONLY
2	141105	4	Large Burner Tube
3	141210	1	3/4" Direct Spark Ignition Manifold (4-port)
4	318714	1	Bracket for Horizontal Facing Gas Valve
5	128927	1	1/2" 24 VAC Redundant (natural gas) Gas Valve
	880960	1	1/2" 24 VAC Direct Spark Ignition Propane Gas Valve Assembly
	882230**	1	ML-758 Propane Conversion Kit
6**	140819	4	#30 Burner Orifice (natural gas) ONLY
	140803	4	#49 Burner Orifice (propane gas) ONLY
7	150103	4	#8-32 x 3/4" Phillips Round Head Machine Screw
8	151001	4	#8-32 Pal Nut
9	150300	5	#10-16 x 1/2" Hex Washer TEK Screw
10	884265	1	Ignitor Probe Assembly
	884279	1	High Voltage Wire with 1/4" Spade Connection
	883031	1	High Voltage Wire with Socket Connection (for models with spike style connection at module)
11	150309	9	#10-16 x 1/2" Hex Head TEK Crimptite Screw
12	152013	2	#6-32 Hex Nut
13	883849	1	Direct Spark Ignition Module with High Voltage Wire
14	810029	1	Direct Spark Ignition Module Mounting Bracket
15	142707	4	1/2" x 1-1/2" Long Black Nipple
16	142506	1	1/2" Street Elbow
17	142600	1	1/2" Black Union
18	142809	1	1/2" x 29-1/8" Nipple
19	319704	1	Hi-Limit Mounting Bracket
20	151000	2	#6-32 Pal Nut
21	150001	2	#6-32 x 1/2" Phillips Round Head Machine Screw
22	130201	1	330 ^g Hi-Limit Manual Reset
23	318700	1	Pipe Bracket (bent)
24	143000	1	3/4" to 1/2" Reducing Coupling
25	154004	1	Twin Speed Nut
26	802799	1	Sail Switch Box Cover and Bracket ONLY
27	122200	1	Sail Switch ONLY
28	150303	2	#4 x 3/4" Pan Head "A" Machine Screw
29	105500	1	Sail Switch Actuator Rod
30	319202	1	Sail Switch Damper (flat)
31	154002	1	1/8" Push-On Fastener

* Burner orifices are not included and must be ordered separately.

** Consult factory for elevations over 2,000 feet.

Electric Oven Assembly

For Models Mfd. as of June 30, 2014

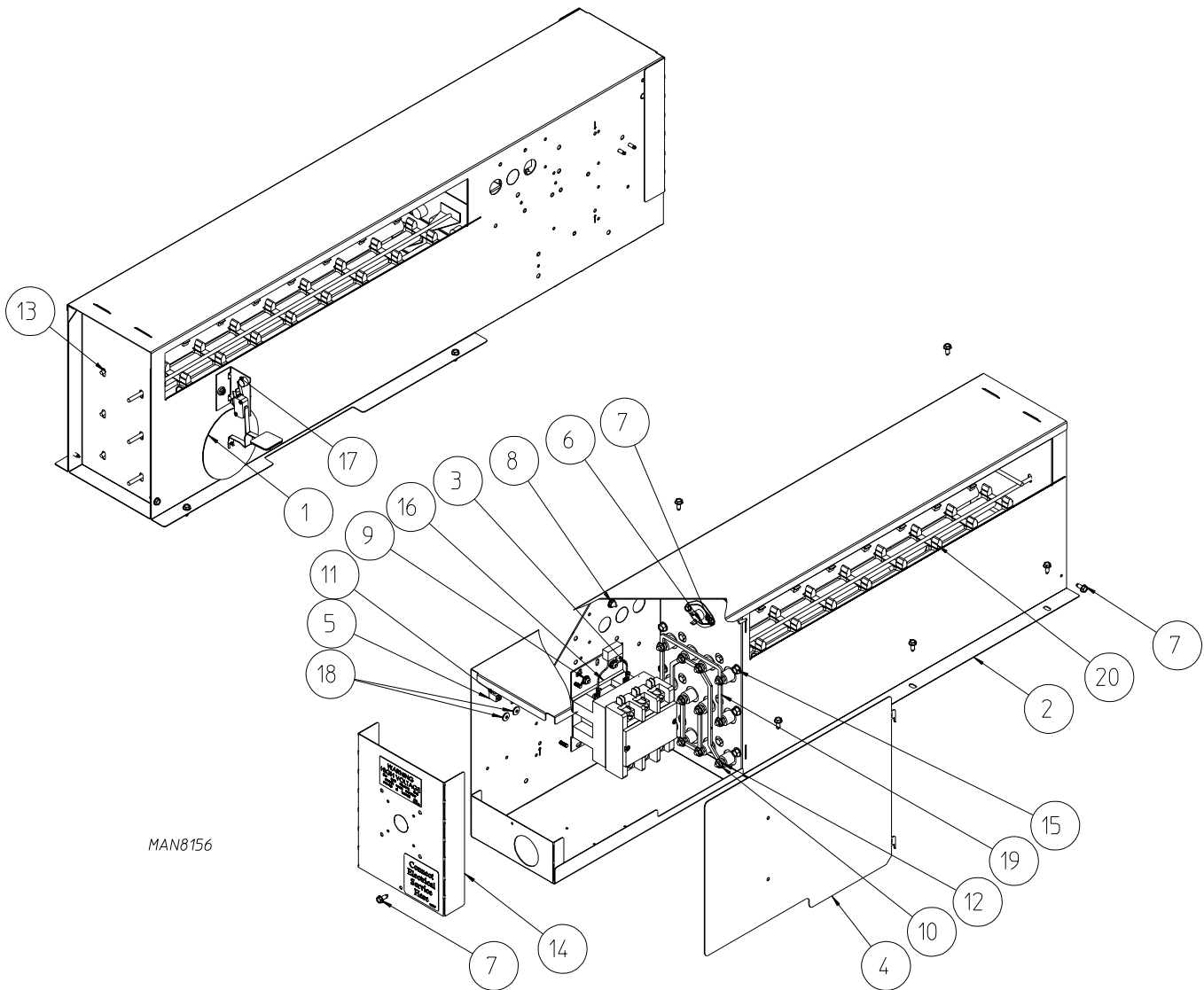

<u>Illus. No.</u>	<u>Part No.</u>	<u>Qty.</u>	<u>Description</u>
1	803375	1	Single Pockets Sail Switch Assembly Linkageless
2	803506	1	Electric Oven
3	824081	1	R.C. Network Assembly
4	320204	1	Electric Oven Relay Box Side
5	121010	1	14-4 Terminal Lug
6	130400	1	Temperature Sensor 400
7	150300	10	#10-16 X 1/2" Hex Washer TEK Screw
8	151000	2	#6-32 Pal Nut
9	151001	3	#8-32 Pal Nut
10	152008	12	#10-32 Hex Nut
11	152014	1	1/4-20 Serrated Hex Flange Nut
12	153009	12	#10 Star Washer
13	320205	1	Electric Oven Front Cover
14	320207	1	Electric Oven Relay Box Cover
15	154505	6	1/4-20 x 3/4" Hex Washer Head Self-Drilling (TEK) Screw
16	-----*	1	Oven Contactor
17	121300	1	Open / Closed Bushing
18	154210	2	5/32" x 3/16" Pop Rivet
19	-----*	1	Oven Jumper Plate
20	-----*	3	Electric Elements

* Refer to Electric Oven Component Application Charts on [page 47](#) and [page 48](#).

Electric Oven Assembly

For Models Mfd. prior to June 30, 2014

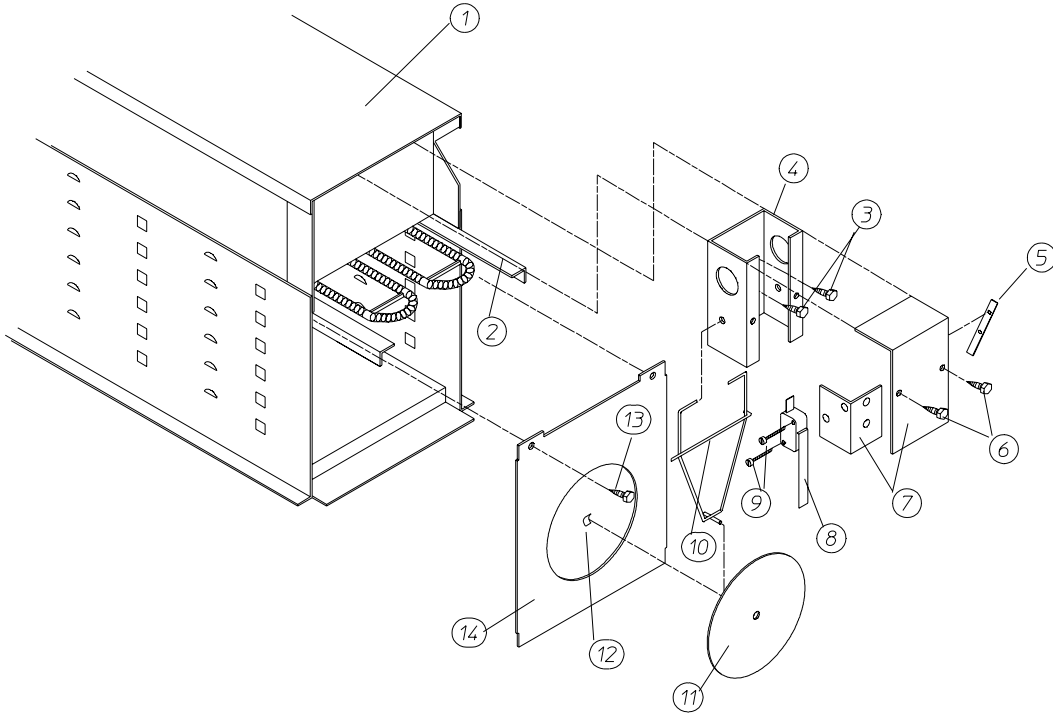

ELECTRIC OVEN (FRONT VIEW)

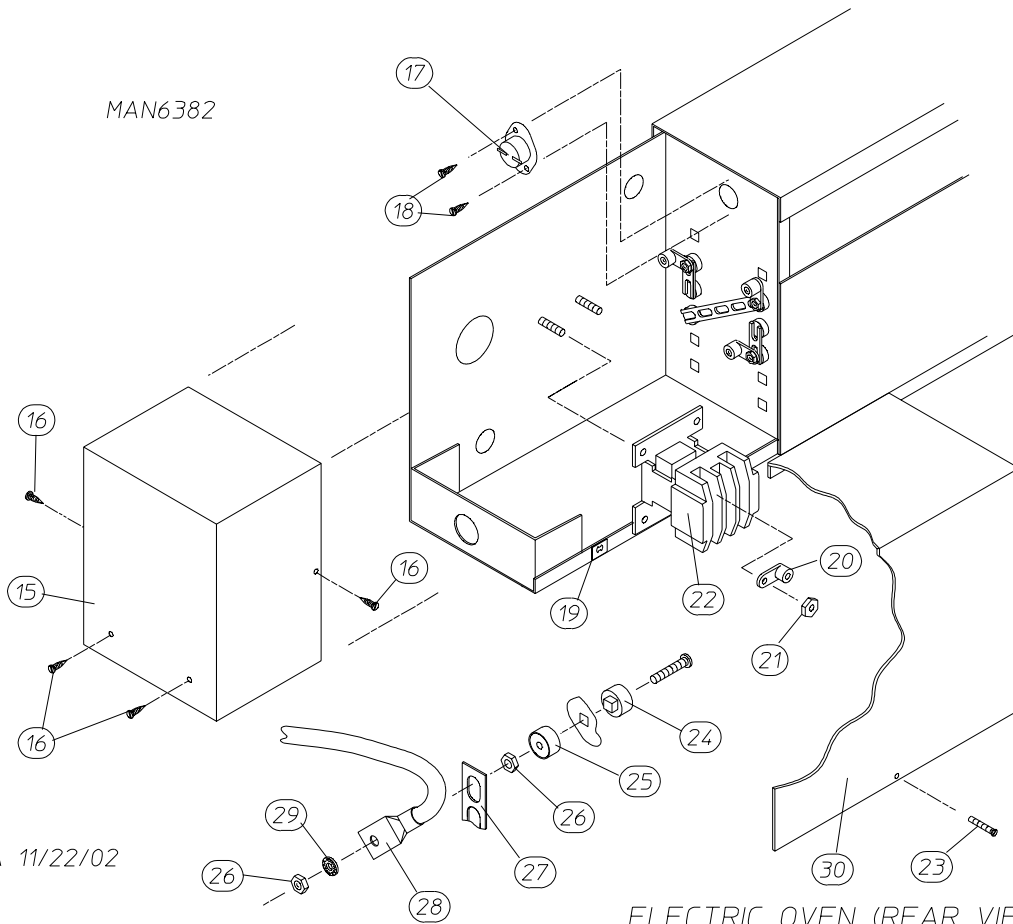

ELECTRIC OVEN (REAR VIEW)

JCARRITA 11/22/02

<u>Illus. No.</u>	<u>Part No.</u>	<u>Qty.</u>	<u>Description</u>
1	835059	1	Large Electric Oven Box ONLY (for microprocessor models)
	803007	1	Large Electric Oven Box ONLY (for dual timer models)
	-----*	1	Electric Oven Assembly Complete
2	-----*	—	Electric Element
3	150300	2	#10-16 x 1/2" Hex Washer TEK Screw
4	802800	1	Sail Switch Box with Bracket and Cover ONLY
	802801	1	Sail Switch Box Assembly Complete (includes illus. nos. 4 through 12)
5	154004	1	Twin Speed Nut
6	130400	1	290° Hi-Limit Thermostat
7	150300	2	#10-16 x 1/2" Hex Washer TEK Screw
8	122200	1	Sail Switch
9	150303	2	#4 x 3/4" Phillips Pan Head Machine Screw
10	105500	1	Sail Switch Actuator Rod
11	319202	1	Sail Switch Damper (flat)
12	154002	1	1/8" Push-On Fastener
13	150300	2	#10-16 x 1/2" Hex Washer TEK Screw
14	803100	1	Electric Oven Front Cover
15	313787	1	Large Relay Box Cover (for microprocessor models)
	320611	1	Large Relay Box Cover (for dual timer models)
16	150301	2	#8-18 x 7/16" Phillips Pan Head TEK Screw
17	802799	1	Sail Switch Box Cover and Bracket ONLY
18	150300	2	#10-16 x 1/2" Hex Washer TEK Screw
19	154001	2	#10-24 Speed Nut
20	121010	1	L-70 Ground Lug
21	152014	3	1/4-20 Free Spin Wash Nut
22	-----*	1	Oven Relay
23	150207	2	#10-24 x 1/2" Phillips Pan Head Machine Screw
24	120081	—	Internal Ceramic Insulator (2 per element)
25	120080	—	External Ceramic Insulator (2 per element)
26	152008	—	#10-32 Hex Nut (4 per element)
27	121011	—	Bus Bar (sold by the foot)
28	-----*	—	Oven Wiring
29	153009	—	#10 Star Washer (2 per element)
30	313781	1	Large Electric Oven Right Side Cover (for microprocessor models)
	320607	1	Large Electric Oven Right Side Cover (for dual timer models)

* Refer to Electric Oven Component Application Charts on [page 47](#) and [page 48](#).

Air-Operated Steam Damper Assembly

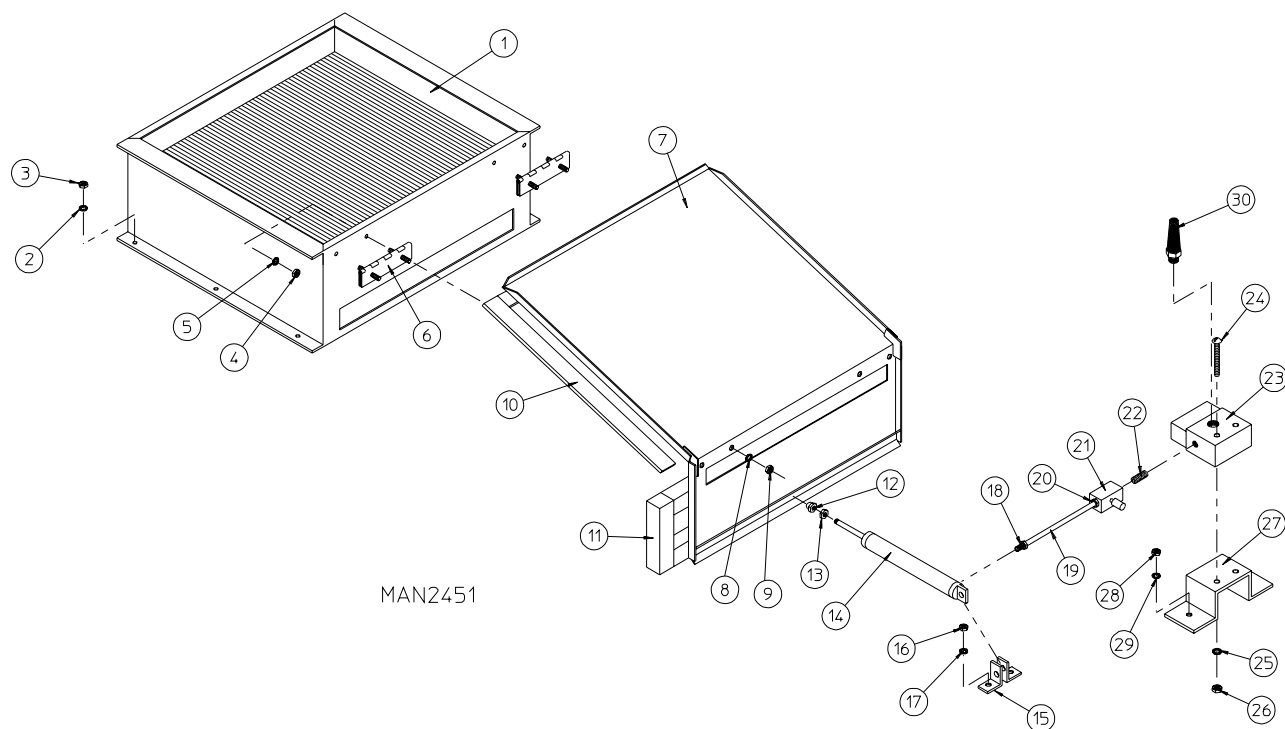

MAN2451

Illus. No.	Part No.	Qty.	Description
1	165009	1	Steam Coil Assembly
2	153002	6	5/16" Lock Washer
3	152004	6	5/16-18 Hex Nut
4	152002	4	1/4-20 Hex Nut
5	153007	4	1/4" Lock Washer
6	820321	2	Steam Damper Hinge Assembly
7	803415	1	Steam Damper Assembly (includes illus. nos. 7, 10, and 11)
8	153007	4	1/4" Lock Washer
9	152002	4	1/4-20 Hex Nut
10	115995	108	Steam Damper Gasket (sold by the inch)
11	102350	1	Steam Damper Foam (68-1/2" length)
12	151007	1	7/16-20 Stainless Steel Acorn Nut
13	152007	1	7/16-20 Hex Nut
14	100497	1	1-1/4" Bore x 3" Stroke Piston
15	100492	1	Piston Support Bracket
16	152002	4	1/4-20 Hex Nut
17	153007	4	1/4" Lock Washer
18	100472	1	1/4" x 1/8" Connector
19	143110	1	1/4" Tubing (sold by the foot)
20	100472	1	1/4" x 1/8" Connector
21	100496	1	1/8" Needle Valve
22	143238	1	1/8" Close Nipple
23	100498	1	3-Way Micro Valve – 24 VAC
24	150002	2	#6-32 x 1" Slotted Machine Screw
25	153010	2	#6 Star Washer
26	152000	2	#6-32 Hex Nut
27	330987	1	Micro Valve Support Bracket
28	152002	2	1/4-20 Hex Nut
29	153007	2	1/4" Lock Washer
30	100520	1	1/8" N.P.T. Silencer (muffler)

Fire Suppression System Assembly

For Models Mfd. as of November 8, 2011

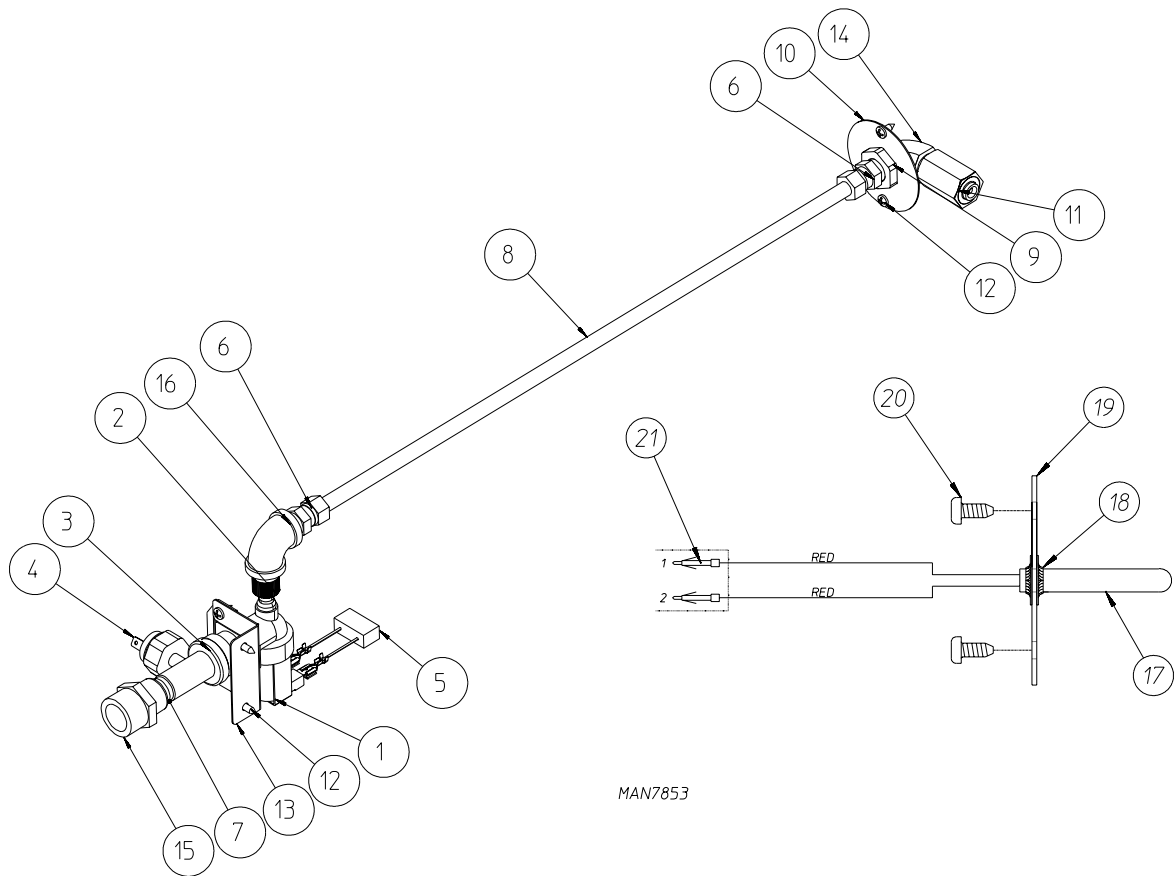

Illus. No.	Part No.	Qty.	Description
1	165119	1	Fire Suppression System H ₂ O Valve 24VAC
2	143183	1	7/16-20 x 3/8" N.P.T. Brass Adaptor
3	143182	1	3/4" G.H.T. x 1/8" x 3/8" N.P.T. Brass Tee
4	136987	1	Water Pressure Switch
5	824081	1	RC Network Assembly
6	143208	2	3/8" Compression x 3/8" M.P.T. Brass Connect
7	143241	1	3/8" x Close Brass Nipple
8	143099	20	3/8" OD x .035 Wall Copper Tubing
9	143303	1	3/8" N.P.T. Brass Lock Nut
10	311588	1	Fire Suppression System Sprinkler Head Mounting Plate
11	143581	1	Fire Suppression System 3GPM 3/8" N.P.T. Spray Nozzle
12	150301	6	#8-18 x 7/16" Phillips Pan Head TEK Screw
13	313962	1	Fire Suppression System 90° Valve Bracket
14	143155	1	3/8" Brass Street Elbow
15	143356	1	3/4" Male x 3/8" F.N.P.T. Brass Bushing
16	143310	1	3/8 Brass 90° Elbow
—	817576	1	Fire Suppression System Assembly Complete (includes illus. nos. 1 through 16)
17	822752	1	Fire Suppression System Temperature Probe Assembly (includes illus. nos. 17 through 19 and 21)
18	159007	2	Push-On Fastener
19	390390	1	Sensor Bracket ONLY
20	150301	2	#8-18 x 7/16" Phillips Pan Head TEK Screw
21	122647	1	Connector ONLY (does not include terminals)

Fire Suppression System Assemblies

For Models Mfd. prior to November 8, 2011

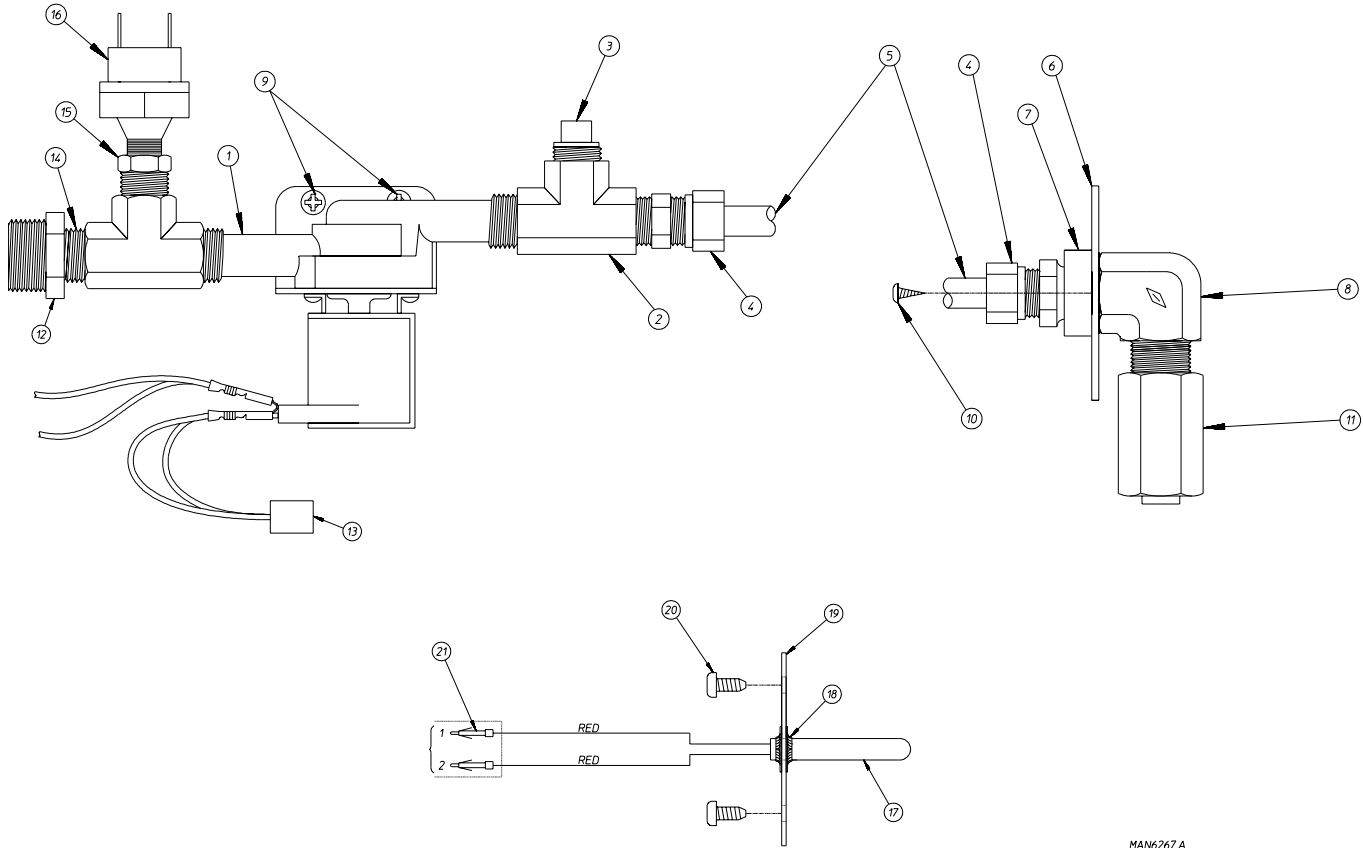

MAN6267.A

Illus. No.	Part No.	Qty.	Description
1	165114	1	Fire Suppression System Solenoid Valve 24V 50/60 Hz
2	143220	2	3/8" F.P.T. Brass Tee
3	143251	1	3/8" M.P.T. Brass Plug
4	143208	2	3/8" Comp x 3/8" M.P.T. Brass Connector
5	143099	6'	3/8" OD x 0.035 Wall Copper Tubing (sold by the foot)
6	311588	1	Sprinkler Head Mounting Plate
7	143303	1	3/8" N.P.T. Brass Locknut
8	143155	1	3/8" Brass Elbow 90°
9	150300	2	#10-16 x 0.5 Hex TEK Screw
10	150301	2	#8-18 x 7/16" TEK Screw
11	143581	1	3 GPM 3/8" F.P.T. Spray Nozzle
12	143356	1	3/4 Male x 3/8 FNPT Brass Bushing
13	824081	1	R.C. Network Assembly
14	143241	1	3/8" x Close Brass Nipple
15	143315	1	3/8" M.N.P.T. x 1/8" F.N.P.T. Brass Bushing
16	136987	1	Water Jet Pressure Switch (for models mfd. as of December 1, 2003)
	817459	1	Fire Suppression System Assembly Complete (includes illus. nos. 1 through 16)
17	822752	1	Fire Suppression System Temperature Probe Assembly (includes illus. nos. 17 through 19 and 21)
18	154007	2	Push-On Fastener
19	390390	1	Sensor Bracket ONLY
20	150301	2	#8-18 x 7/16" Phillips Pan Head TEK Screw
21	122647	1	Connector ONLY (does not include terminals)

Single-Phase (1Ø) Microprocessor Rear Electric Relay Panel Assembly

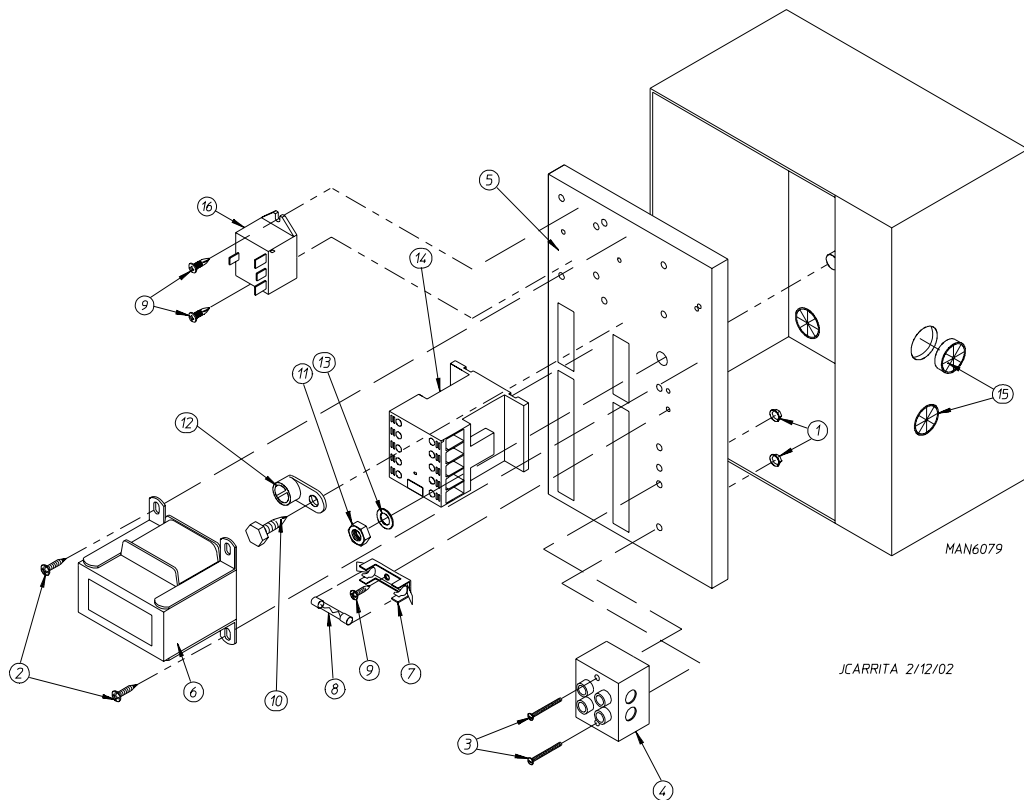

JCARRITA 2/12/02

Illus. No.	Part No.	Qty.	Description
1	151000	2	#6-32 Pal Nut
2	150300	2	#10-16 x 1/2" Hex Washer TEK Screw
3	150009	2	#6-32 x 1-1/2" Phillips Pan Head Machine Screw
4	120716	1	2-Position Terminal Block
5	322812	1	Rear Electric Mounting Plate ONLY
	830468	1	Rear Electric Panel Assembly Complete – 115 Volt (1Ø) (for gas models Only) (includes illus. nos. 1 through 14)
	830477	1	Rear Electric Panel Assembly Complete – 115 Volt (1Ø) (for steam models Only) (includes illus. nos. 1 through 14)
	830469	1	Rear Electric Panel Assembly Complete – 208-240 Volt (1Ø) (for gas models Only) (includes illus. nos. 1 through 14)
	830478	1	Rear Electric Panel Assembly Complete – 208-240 Volt (1Ø) (for steam models Only) (includes illus. nos. 1 through 14)
	830131	1	Rear Electric Panel Assembly Complete – 208-240 Volt (for electric models Only) (includes illus. nos. 1 through 14 and 16)
6	132070	1	Transformer Assembly 115 – 208-240 Volt (for gas and steam models Only)
	822792	1	Transformer Assembly – 208-240 Volt (for electric models Only)
7	136008	*	Fuse Holder
8	136057	*	1/2-Amp (Slo-Blo) Fuse
9	150301	1	#8-18 x 7/16" Phillips Pan Head TEK Screw
10	150297	1	#10 x 1/2" Green Hex Washer TEK Screw
11	152004	1	5/16-18 Hex Nut
12	121010	1	L-70 Ground Lug
13	153002	1	5/16" Lock Washer
14	132514	1	3-Pole Contactor (115 volt models)
	132496	1	3-Pole Contactor (208-240 volt models)
15	121300	3	Open / Closed Bushing
16	131932	1	24V SPST Relay (for electric models Only)

* Quantity is 1 for 115v and 2 for 208-240v.

208-240V 3-Phase (3Ø) Microprocessor Rear Electric Relay Panel Assembly

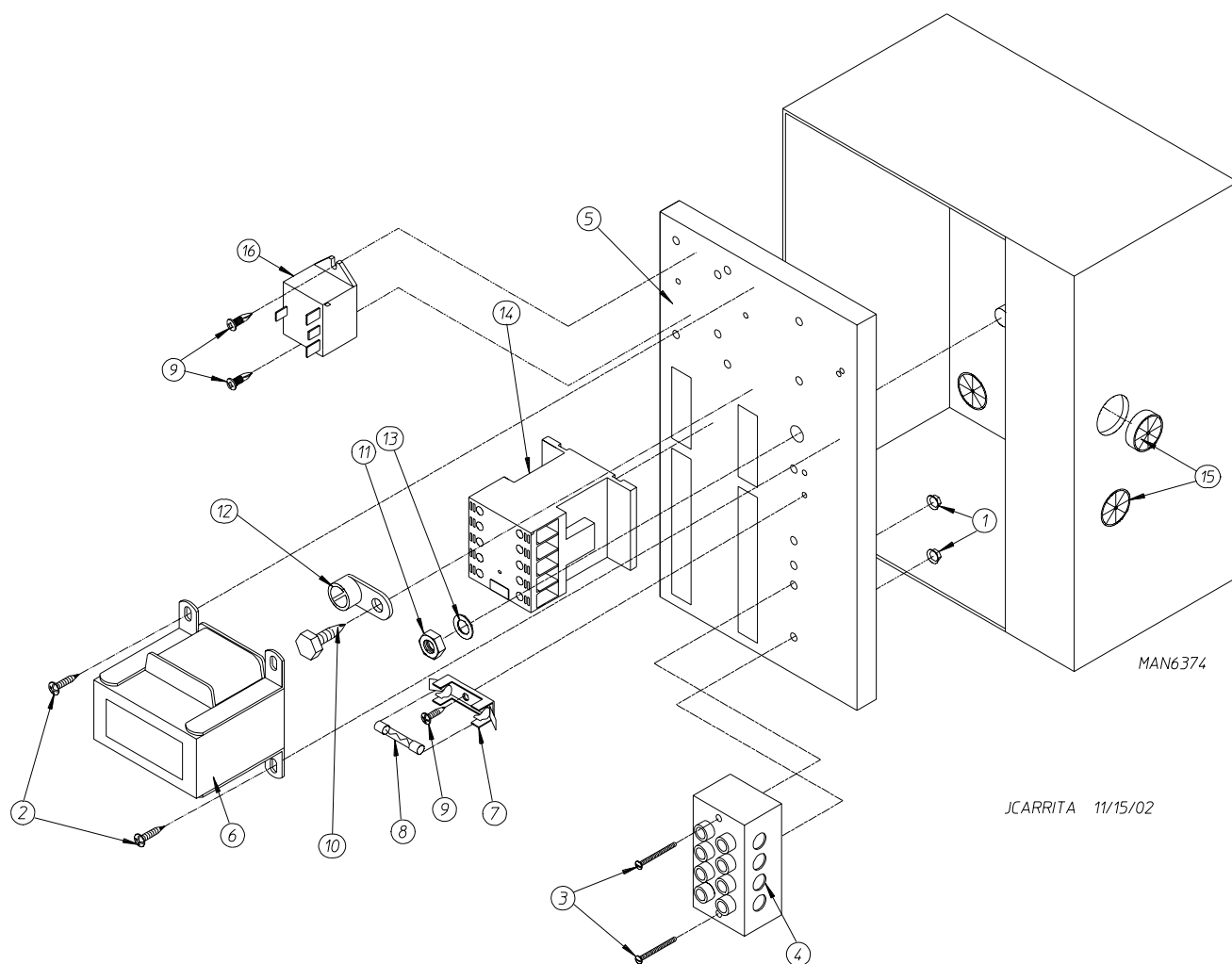

Illus. No.	Part No.	Qty.	Description
1	151000	2	#6-32 Pal Nut
2	150300	2	#10-16 x 1/2" Hex Washer TEK Screw
3	150008	2	#6-32 x 1-1/4" Phillips Pan Head Machine Screw
4	120701	1	4-Position Terminal Block
5	322812	1	Rear Electric Mounting Plate ONLY
	830470	1	Rear Electric Panel Assembly Complete – 208-240 Volt (for gas models Only) (includes illus. nos. 1 through 14)
	830480	1	Rear Electric Panel Assembly Complete – 208-240 Volt (for steam models Only) (includes illus. nos. 1 through 14)
	830157	1	Rear Electric Panel Assembly Complete – 208-240 Volt (for electric models Only) (includes illus. nos. 1 through 14 and 16)
6	132070	1	Transformer (for gas and steam models Only)
	822792	1	Transformer (for electric models Only)
7	136008	2	Fuse Holder
8	136057	2	1/2-Amp (Slo-Blo) Fuse
9	150301	4	#8-18 x 7/16" Phillips Pan Head TEK Screw
10	150297	1	#10 x 1/2" Green Hex Washer TEK Screw
11	152004	1	5/16-18 Hex Nut
12	121010	1	L-70 Ground Lug
13	153002	1	5/16" Lock Washer
14	132495	1	3-Pole Contactor
15	121300	3	Open / Closed Bushing
16	131932	1	24V SPST Relay (for electric models Only)

460-480V Microprocessor Rear Electric Relay Panel Assembly

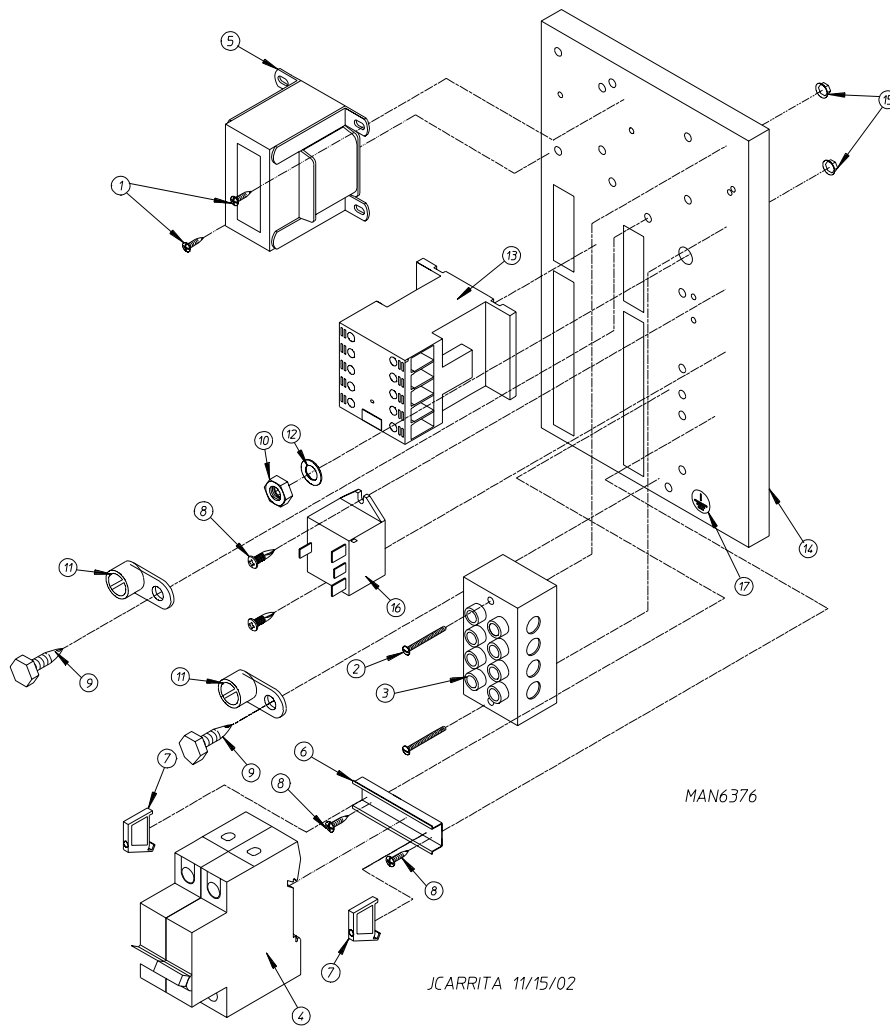

Illus. No.	Part No.	Qty.	Description
1	150300	2	#10-16 x 1/2" Hex Washer TEK Screw
2	150008	2	#6-32 x 1-1/4" Phillips Pan Head Machine Screw
3	120701	1	4-Position Terminal Block
4	135501	1	2-Pole 1-Amp Circuit Breaker
5	132067	1	Transformer 460-480 Volt
6	120768	2	35 x 15mm Din Rail
7	120765	2	Standard End Bracket
8	150301	4	#8-18 x 7/16" Phillips Pan Head TEK Screw
9	150297	2	#10 x 1/2" Green Hex Washer TEK Screw
10	152004	1	5/16-18 Hex Nut
11	121010	2	L-70 Ground Lug
12	153002	1	5/16" Lock Washer
13	132495	1	3-Pole Contactor
14	322812	1	Rear Electric Mounting Plate ONLY
	830474	1	Rear Electric Panel Assembly Complete – 460-480 Volt (for gas models Only) (includes illus. nos. 1 through 14)
	830486	1	Rear Electric Panel Assembly Complete – 460-480 Volt (for steam models Only) (includes illus. nos. 1 through 14)
	830199	1	Rear Electric Panel Assembly Complete – 460-480 Volt (for electric models Only) (includes illus. nos. 1 through 14)
15	151000	2	#6-32 Pal Nut
16	131932	1	24V SPST Relay (for electric models Only)
17	112075	1	Ground Label

208-240V Microprocessor Reversing Rear Electric Relay Panel Assembly

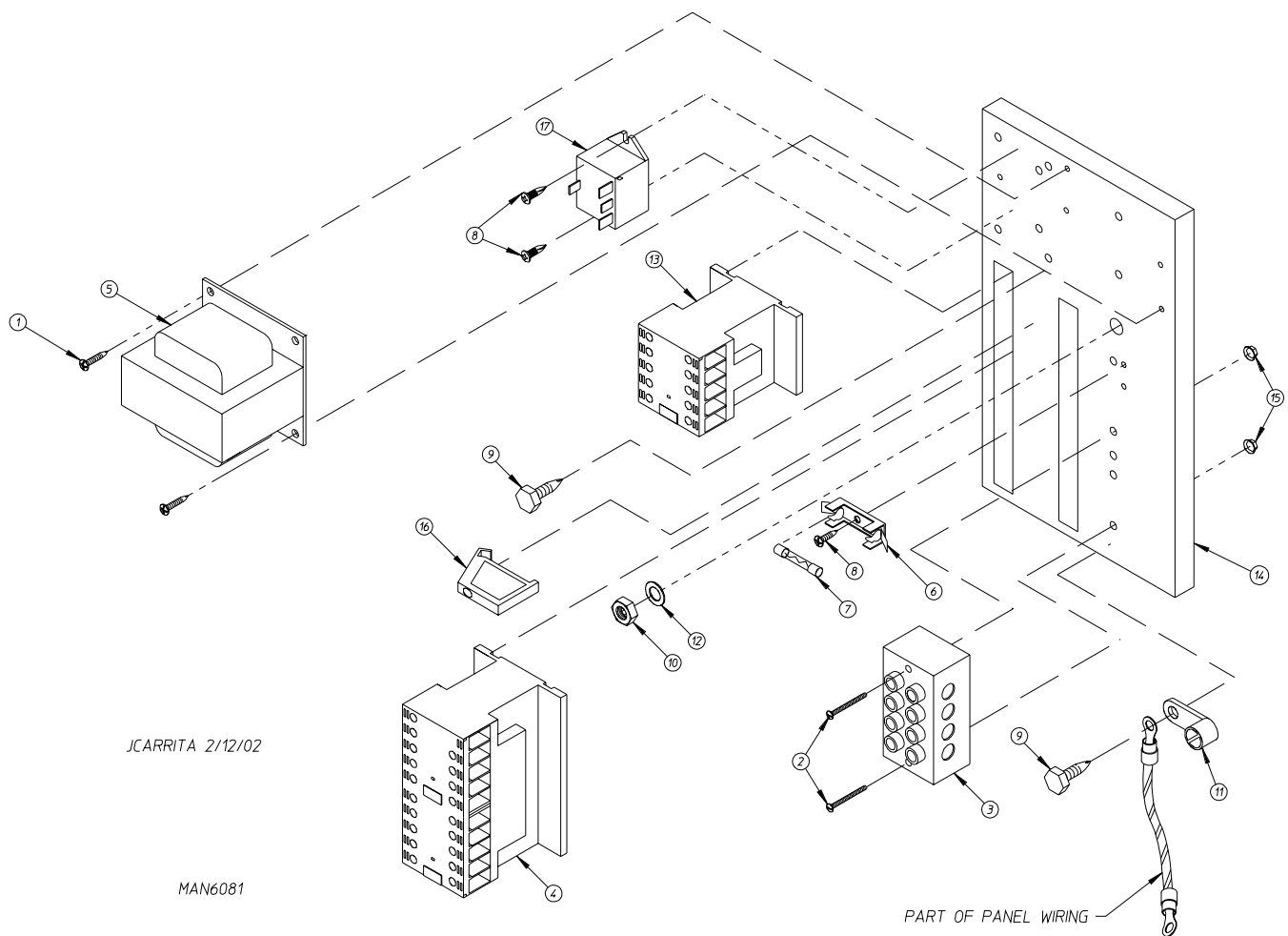

Illus. No.	Part No.	Qty.	Description
1	150300	2	#10-16 x 1/2" Hex Washer TEK Screw
2	150008	2	#6-32 x 1-1/4" Phillips Pan Head Machine Screw
3	120701	1	4-Position Terminal Block
4	132497	1	3-Pole Reversing Contactor
5	822764	1	Transformer 208-240 Volt (for gas and steam models Only)
	822792	1	Transformer 208-240 Volt (for electric models Only)
6	136008	2	Fuse Holder
7	136057	2	1/2-Amp (Slo-Blo) Fuse
8	150301	4	#8-18 x 7/16" Phillips Pan Head TEK Screw
9	150297	2	#10 x 1/2" Green Hex Washer TEK Screw
10	152004	1	5/16-18 Hex Nut
11	121010	1	L-70 Ground Lug
12	153002	1	5/16" Lock Washer
13	132495	1	3-Pole Contactor
14	322812	1	Rear Electric Mounting Plate ONLY
	830471	1	Rear Electric Panel Assembly Complete – 208-240 Volt (3Ø) (for gas models Only) (includes illus. nos. 1 through 16)
	830482	1	Rear Electric Panel Assembly Complete – 208-240 Volt (3Ø) (for steam models Only) (includes illus. nos. 1 through 16)
	822789	1	Rear Electric Panel Assembly Complete – 208-240 Volt (3Ø) (for electric models Only) (includes illus. nos. 1 through 17)
15	151000	2	#6-32 Pal Nut
16	120765	1	Standard End Bracket
17	131932	1	24V SPST Relay (for electric models Only)

460-480V Microprocessor Reversing Rear Electric Relay Panel Assembly

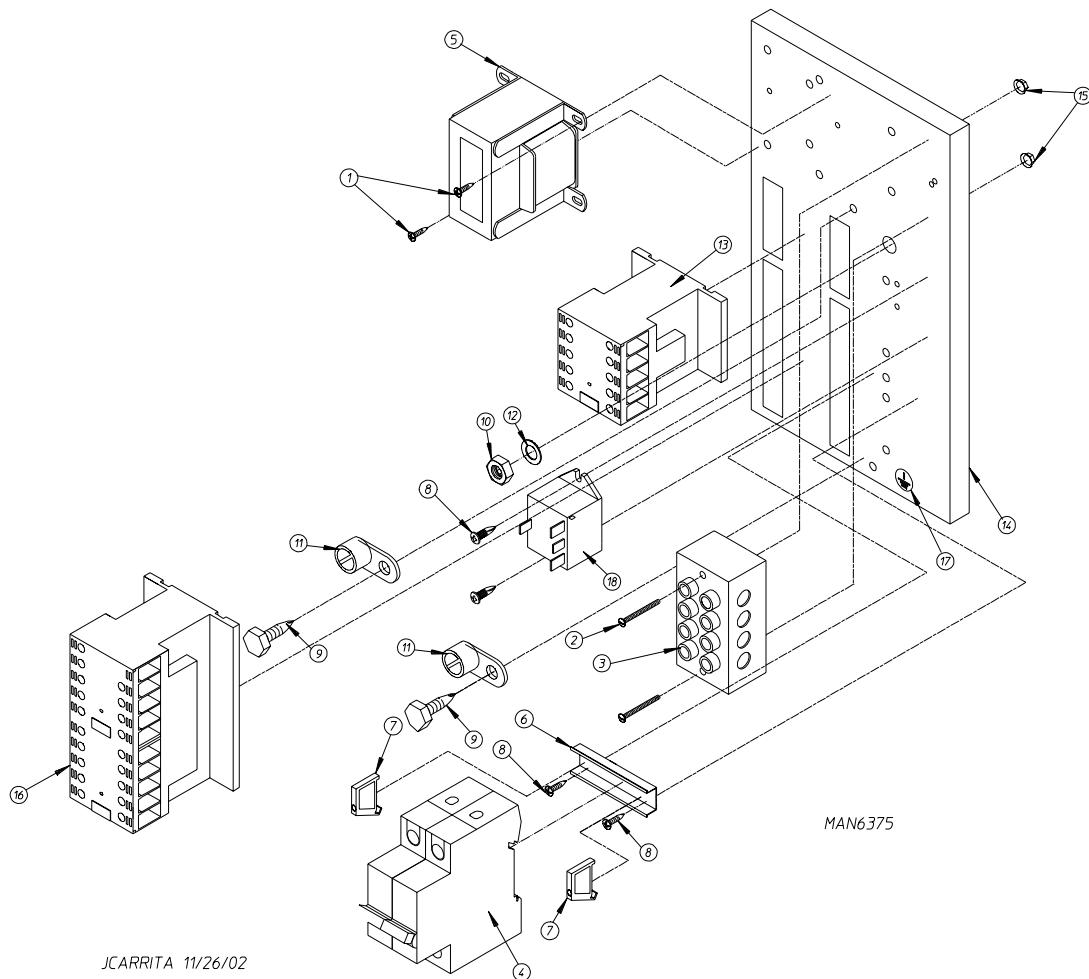

Illus. No.	Part No.	Qty.	Description
1	150300	2	#10-16 x 1/2" Hex Washer TEK Screw
2	150009	2	#6-32 x 1-1/2" Phillips Pan Head Machine Screw
3	120701	1	4-Position Terminal Block
4	135501	1	2-Pole 1-Amp Circuit Breaker
5	132067	1	Transformer 460-480 Volt
6	120768	2	35 x 15mm Din Rail
7	120765	2	Standard End Bracket
8	150301	4	#8-18 x 7/16" Phillips Pan Head TEK Screw
9	150297	2	#10 x 1/2" Green Hex Washer TEK Screw
10	152004	1	5/16-18 Hex Nut
11	121010	2	L-70 Ground Lug
12	153002	1	5/16" Lock Washer
13	132495	1	3-Pole Contactor
14	322812	1	Rear Electric Mounting Plate ONLY
	830475	1	Rear Electric Panel Assembly Complete – 460-480 Volt (for gas models Only) (includes illus. nos. 1 through 16)
	830487	1	Rear Electric Panel Assembly Complete – 460-480 Volt (for steam models Only) (includes illus. nos. 1 through 16)
	824371	1	Rear Electric Panel Assembly Complete – 460-480 Volt (for electric models Only) (includes illus. nos. 1 through 17)
15	151000	2	#6-32 Pal Nut
16	132497	1	3-Pole Reversing Contactor
17	112075	1	Ground Label
18	131932	1	24V SPST Relay (for electric models Only)

Single-Phase (1Ø) Dual Timer Rear Electric Relay Panel Assembly

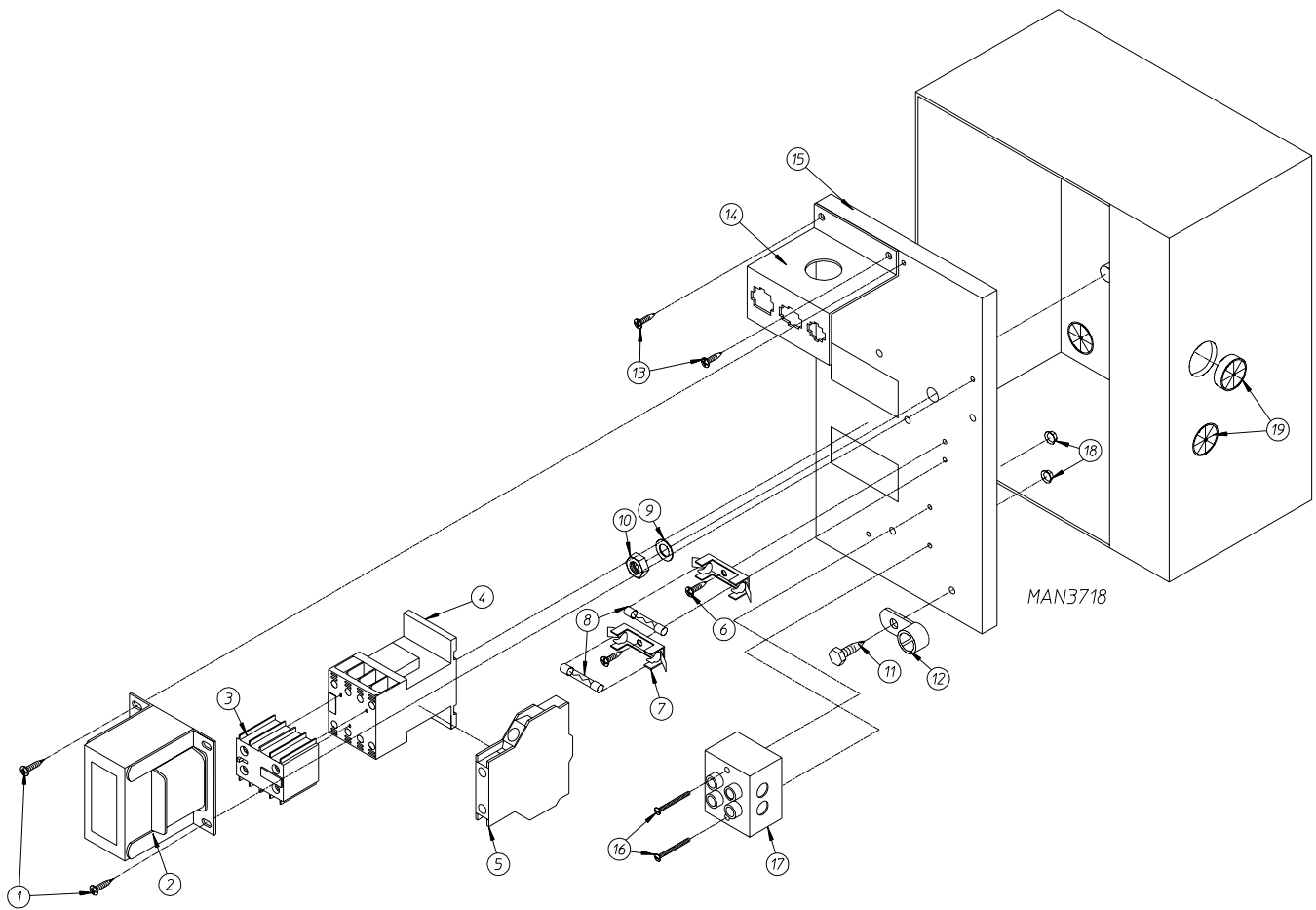

Illus. No.	Part No.	Qty.	Description
1	150300	2	#10-16 x 1/2" Hex Washer TEK Screw
2	825462	1	24 VAC Transformer (for 115 volt gas models Only)
	825463	1	24 VAC Transformer (for 208-240 volt models Only)
3	132449	1	2-Pole Contact Block (for 208-240 volt models Only)
4	132445	1	3-Pole Contactor
5	132383	1	2-Pole Contact Block (for 120 volt models Only)
6	150301	*	#8-18 x 7/16" Phillips Pan Head TEK Screw
7	136008	*	Fuse Holder
8	136049	*	3/4-Amp (Slo-Blo) Fuse
9	153002	1	5/16" Lock Washer
10	152004	1	5/16-18 Hex Nut
11	150297	1	#10 x 1/2" Green Hex Washer TEK Screw
12	121010	1	L-70 Ground Lug
13	150300	2	#10-16 x 1/2" Hex Washer TEK Screw
14	353258	1	Rear Panel Connector Bracket
15	306304	1	Rear Electric Mounting Panel ONLY
	825445	1	Rear Electric Panel Assembly Complete – 115 Volt (for gas models Only) (includes illus. nos. 1, 2, and 4 through 18)
	825446	1	Rear Electric Panel Assembly Complete – 208-240 Volt (for gas models Only) (includes illus. nos. 1 through 4 and 6 through 18)
16	150009	2	#6-32 x 1-1/2" Phillips Round Head Machine Screw
17	120716	1	2-Position Terminal Block
18	151000	2	#6-32 Pal Nut
19	121300	3	Open / Closed Bushing

* Quantity is 1 for 115v and 2 for 208-240v.

460-480V Dual Timer Rear Electric Relay Panel Assembly

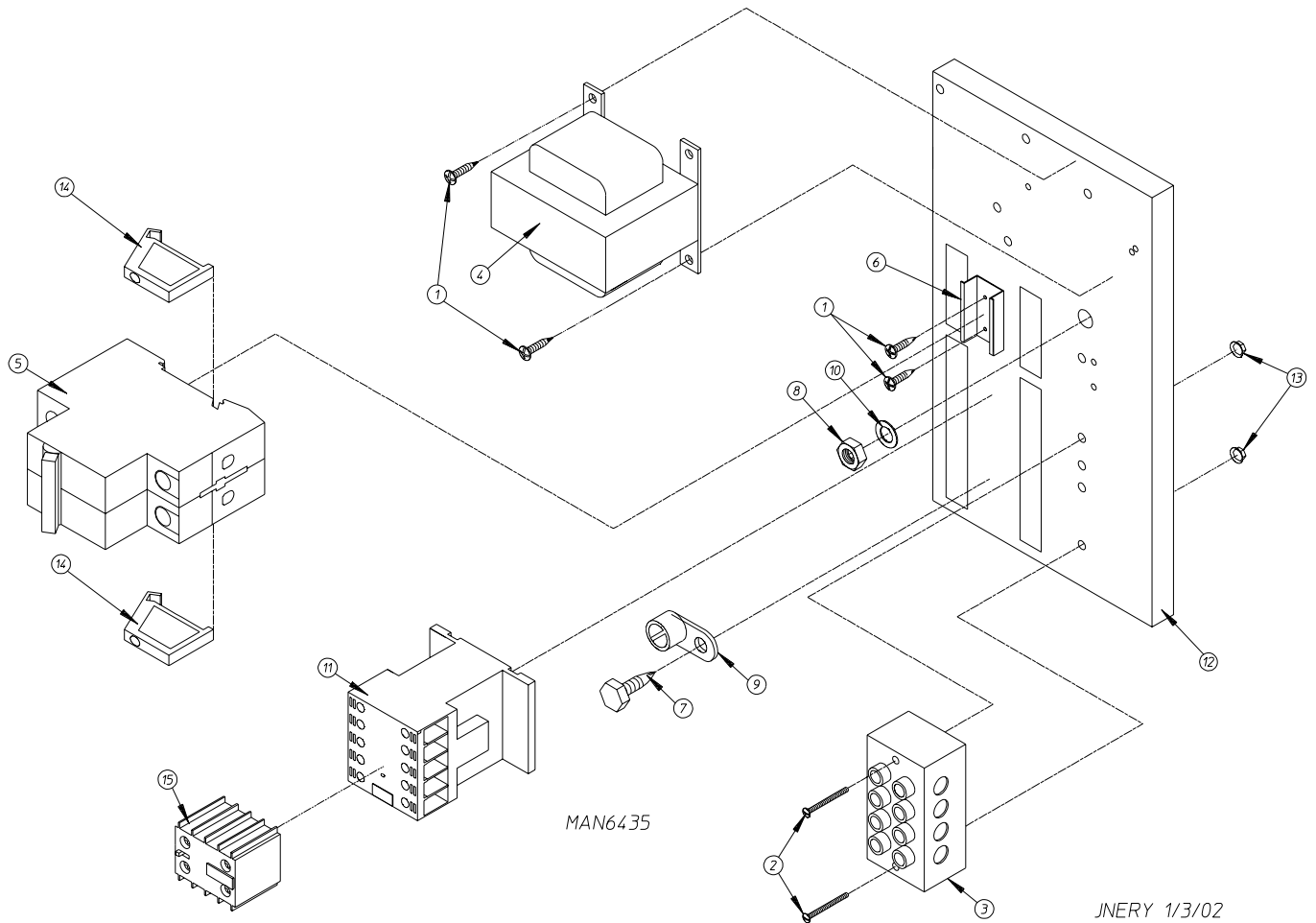

Illus. No.	Part No.	Qty.	Description
1	150300	2	#10-16 x 1/2" Hex Washer TEK Screw
2	150008	2	#6-32 x 1-1/4" Phillips Round Head Machine Screw
3	120701	1	4-Position Terminal Block
4	835143	1	24 VAC Transformer (gas models Only)
5	135501	1	1-Amp Double-Pole Circuit Breaker
6	120768	2	Din Rail (sold by the inch)
7	150297	1	#10 x 1/2" Hex Washer TEK Screw – Green
8	152004	1	5/16-18 Hex Nut
9	121010	1	L-70 Ground Lug
10	153002	1	5/16" Lock Washer
11	132447	1	3-Pole Contactor
12	322812	1	Rear Electric Mounting Panel ONLY
	824231	1	Rear Electric Panel Assembly Complete (for gas models Only) (includes illus. nos. 1 through 15)
13	151000	2	#6-32 Pal Nut
14	120765	2	Din Rail End Stop
15	132449	1	2-Pole Contact Block

208-240V Dual Timer Reversing Rear Electric Relay Panel Assembly

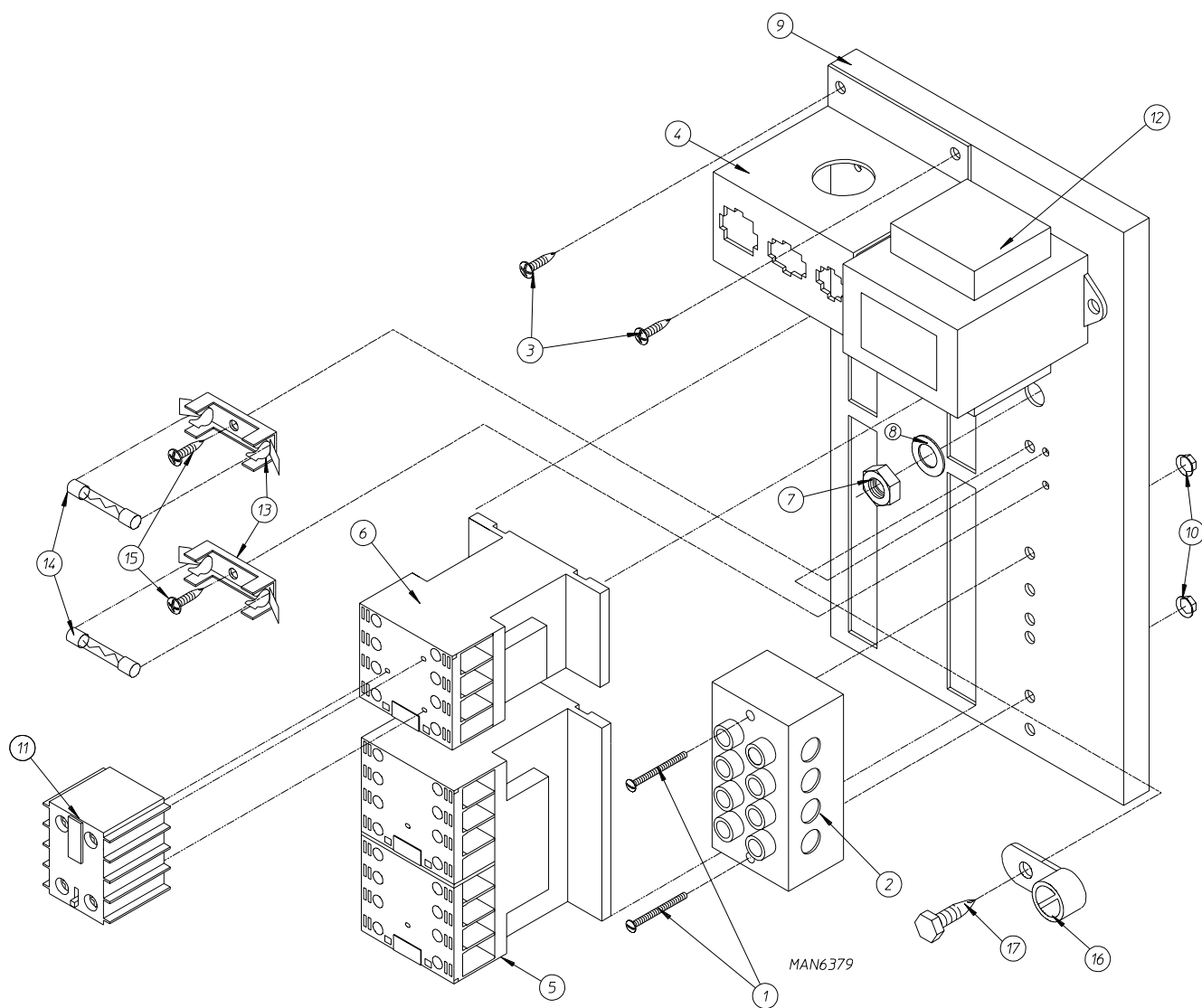

JCARRITA 11/15/02

Illus. No.	Part No.	Qty.	Description
1	150009	2	#6-32 x 1-1/2" Phillips Round Head Machine Screw
2	120701	1	4-Position Terminal Block
3	150300	2	#10-16 x 1/2" Hex Washer TEK Screw
4	353258	1	Rear Panel Connector Bracket
5	132497	1	Reversing Contactor
6	132495	1	Blower Motor Contactor
7	152004	1	5/16-18 Hex Nut
8	153002	1	5/16" Lock Washer
9	322812	1	Rear Electric Mounting Panel ONLY
	830236	1	Rear Electric Panel Assembly Complete (for gas models Only) (includes illus. nos. 1 through 17)
10	151000	2	#6-32 Pal Nut
11	132449	1	2-Pole Contact Block
12	830238	1	24 VAC Transformer (for gas models Only)
13	136008	2	Fuse Holder
14	136057	2	1/2-Amp (Slo-Blo) Fuse
15	150301	2	#8-18 x 7/16" Phillips Pan Head TEK Screw
16	121010	1	L-70 Ground Lug
17	150297	1	#10 x 1/2" Hex Washer TEK Screw – Green

Outer Top / Back Guard Assemblies

For Models Mfd. as of January 5, 2003

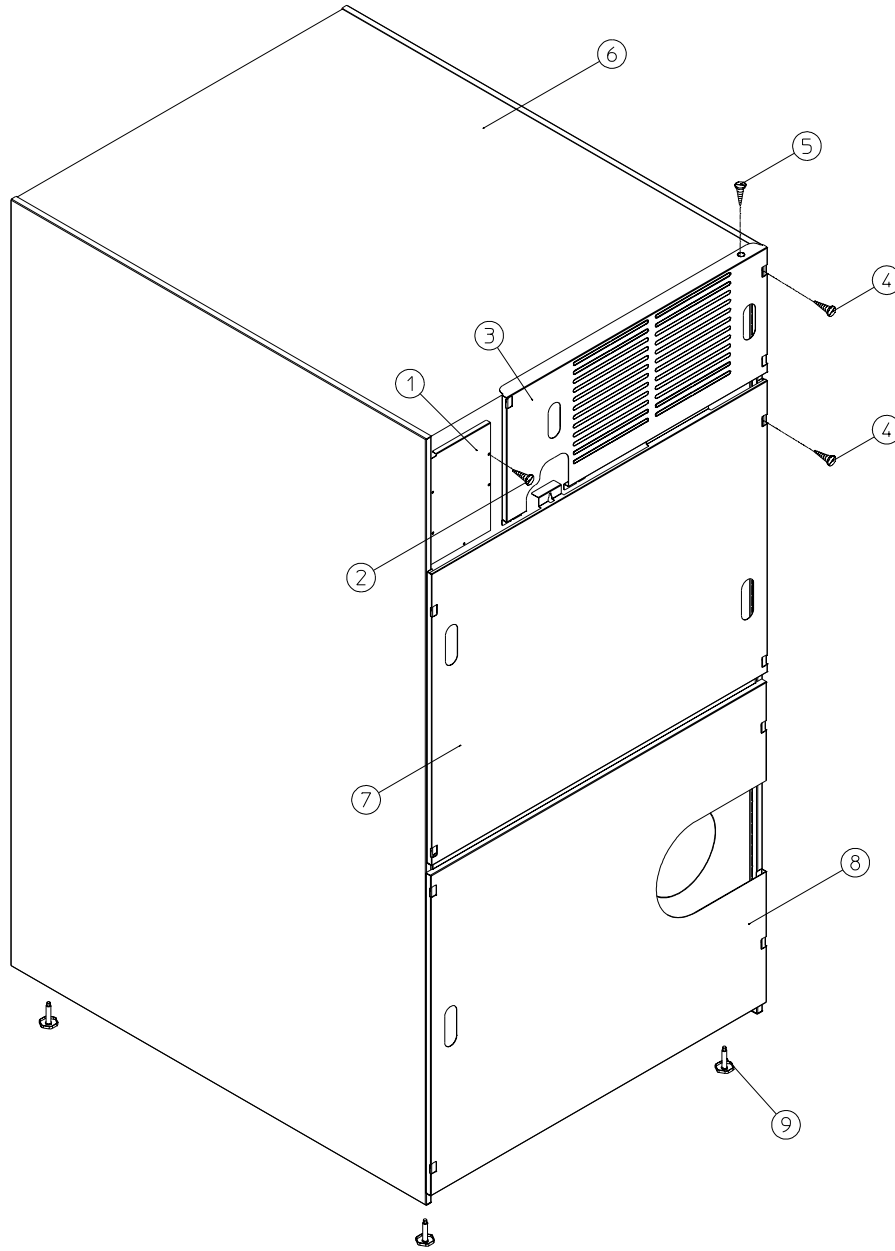

MAN7536

Illus. No.	Part No.	Qty.	Description
1	322809	1	Back Electrical Box Cover
2	150301	4	#8-18 x 7/16" Phillips Pan Head TEK Screw
3*	314534	1	Top Back Guard (for gas models Only)
	314540	1	Top Back Guard (for electric models Only)
4	150301	7	#8-18 x 7/16" Phillips Pan Head TEK Screw
5	150300	10	#10-16 x 1/2" Hex Washer TEK Screw
6*	312527	1	Outer Top (for gas models Only)
	320007	1	Outer Top (for electric models Only)
7	314535	1	Middle Back Guard
8	314539	1	Bottom Back Guard
9	103500	4	Leveling Leg

* There is no outer top or top back guard on steam models.

Outer Top / Back Guard Assemblies

For Models Mfd. prior to January 5, 2003

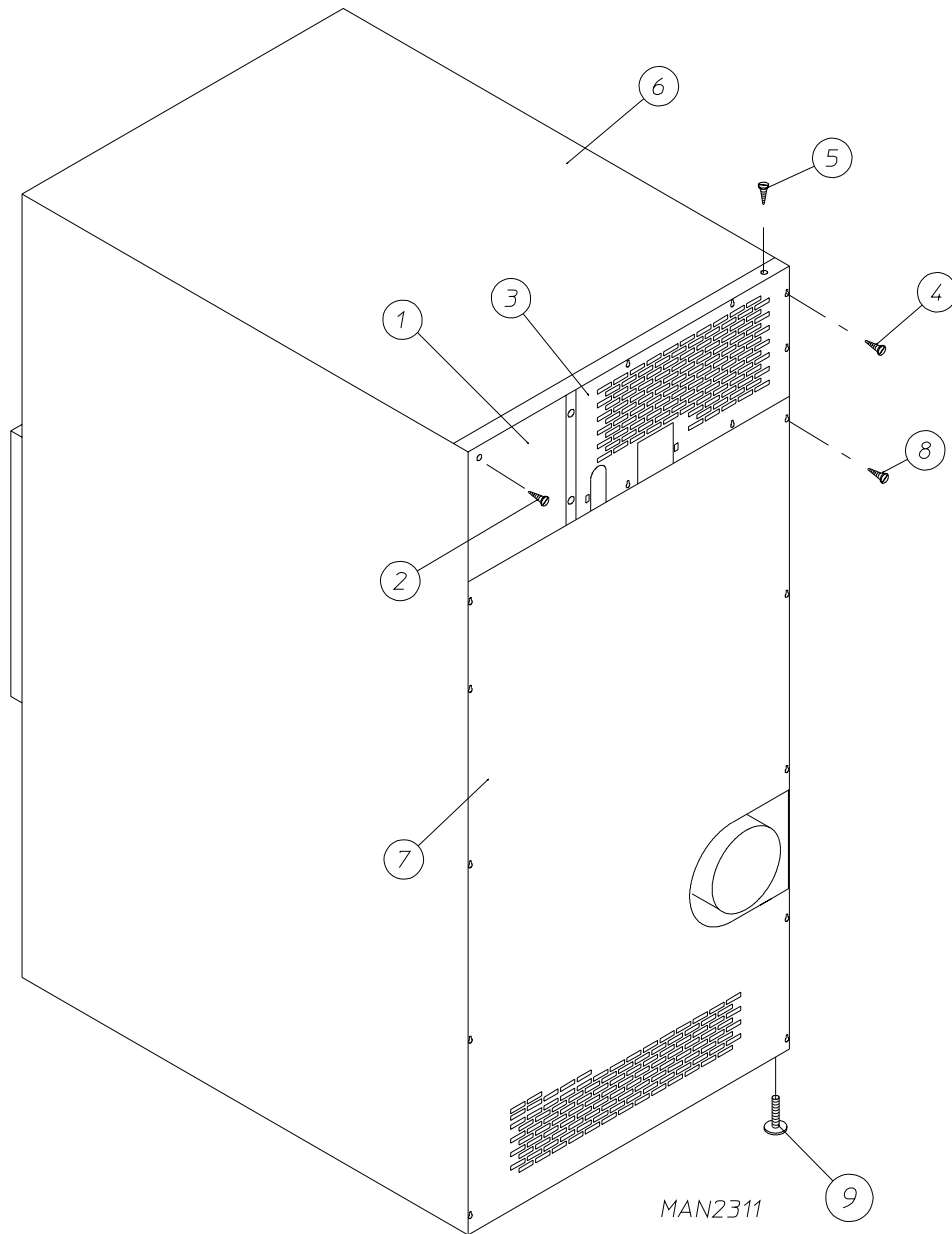

Illus. No.	Part No.	Qty.	Description
1	322809	1	Back Electrical Box Cover
2	150301	4	#8-18 x 7/16" Phillips Pan Head TEK Screw
3*	323738	1	Top Back Guard (for gas models Only)
	320008	1	Top Back Guard (for electric models Only)
4	150301	7	#8-18 x 7/16" Phillips Pan Head TEK Screw
5	150300	10	#10-16 x 1/2" Hex Washer TEK Screw
6*	312527	1	Outer Top (for gas models Only)
	320007	1	Outer Top (for electric models Only)
7	314518	1	Bottom Back Guard
8	150301	13	#8-18 x 7/16" Phillips Pan Head TEK Screw
9	103500	4	Leveling Leg

* There is no outer top or top back guard on steam models.

For models mfd. as of June 30, 2014

kW	Volt	Phase	Wire	Oven Assembly Part No.	Elements			Oven Wire			Terminal Lug		Bus Bar	Oven Relay	
					Qty.	kW	Part No.	Qty.	Size	Part No.	Qty.	Part No.		Part No.	Part No.
30	480	3Ø	3 or 4	805678	3	10	119985	1	#8	805615	1	121010	320206	131377	131377
30	416	3Ø	3 or 4	805680	3	10	119985	1	#8	805615	1	121010	320211	131377	131377
30	240	3Ø	3 or 4	805682	3	10	119985	1	#2	805631	1	121010	320208	131363	131363
30	208	3Ø	3 or 4	805684	3	10	119983	1	#2	805631	1	121010	320208	131363	131363
24	480	3Ø	3 or 4	805690	3	8	119980	1	#8	805615	1	121010	320206	131379	131379
24	208	3Ø	3 or 4	805689	3	8	119981	1	#8	805631	1	121010	320208	131363	131363

For models mfd. prior to June 30, 2014

kW	Volt	Phase	Wire	Oven Assembly Part No.	Elements			Oven Wire			Terminal Lug		Bus Bar P/N	Oven Relay	
					Qty.	kW	Part No.	Qty.	Size	Part No.	Qty.	Part No.		Part No.	Part No.
36	480	3Ø	3 or 4	824408	6	6	120014	1	#8	882572	1	121010	1	131359	131359
33	380	3Ø	3 or 4	830904	6	6	120002	1	#6	830403	1	121010	1	131359	131359
30	208	3Ø	3 or 4	835060	6	5	120012	1	#2	823066	1	121010	1	131362	131362
30	240	3Ø	3	833124	6	5	120013	1	#4	882566	1	121010	1	131363	131363
30	480	3Ø	3 or 4	826222	6	5	120013	1	#8	882572	1	121010	1	131357	131357
25	380	3Ø	3 or 4	833136	6	5	120013	1	#8	882571	1	121010	1	131357	131357
24	208	3Ø	3 or 4	835054	6	4	120010	1	#4	882566	1	121010	1	131363	131363

* Consult factory for oven assemblies not listed.

Dual Timer Electric Oven Component Application Chart

For models mfd. as of June 30, 2014

kW	Volt	Phase	Wire	Oven Assembly Part No.	Elements			Oven Wire			Terminal Lug		Bus Bar	Oven Relay Part No.
					Qty.	kW	Part No.	Qty.	Size	Part No.	Qty.	Part No.		
30	480	3Ø	3 or 4	805679	3	10	119985	1	#8	805615	1	121010	320206	131377
30	416	3Ø	3 or 4	805681	3	10	119985	1	#8	805615	1	121010	320211	131377
30	240	3Ø	3 or 4	805683	3	10	119985	1	#2	805631	1	121010	320208	131363
30	208	3Ø	3 or 4	805685	3	10	119983	1	#2	805631	1	121010	320208	131363
24	480	3Ø	3 or 4	805697	3	8	119980	1	#8	805615	1	121010	320206	131379
24	208	3Ø	3 or 4	805685	3	8	119981	1	#8	805631	1	121010	320208	131363

For models mfd. prior to June 30, 2014

kW	Volt	Phase	Wire	Oven Assembly Part No. *	Elements			Oven Wire			Terminal Lug		Bus Bar P/N	Oven Relay Part No.
					Qty.	kW	Part No.	Qty.	Size	Part No.	Qty.	Part No.		
36	208	3Ø	3 or 4	824921	6	6	120015	1	#2	823066	1	121010	121011	131362
36	240	3Ø	3	824026	6	6	120014	1	#2	882562	1	121010	1	131362
36	460/480	3Ø	3 or 4	802764	6	6	120014	1	#8	882572	1	121010	1	131359
33	380	3Ø	3 or 4	827044	6	6	120002	1	#6	882568	1	121033	1	131359
30	208	3Ø	3 or 4	825376	6	5	120012	1	#2	823066	1	121010	1	131362
30	240	3Ø	3	840259	6	5	120013	1	#4	882566	1	121010	1	131363
30	416	3Ø	3 or 4	835064	6	5	120013	1	#8	882571	1	121010	1	131357
30	460/480	3Ø	3 or 4	834804	6	5	120013	1	#8	882572	1	121010	1	131357
24	208	3Ø	3 or 4	816138	6	4	120010	1	#4	882566	1	121010	1	131363

* When ordering oven assembly complete, specify 3-wire or 4-wire when applicable, as well as if dryer has microprocessor controller (computer) or non-microprocessor controls.

<u>Part No.</u>	<u>Description</u>
112075	1/2" Dia. Ground Symbol Label
112280	"Clean Lint Screen" Label
114001	"CAUTION – Exhaust / Lint Screen" Label
114006	"WARNING – Fire Hazards" Label
117505	Aluminum Duct Tape (sold by the foot)
120100	3/8" Straight (BX) Connector
120400	3/8" Red Jacket (BX) Insulator
120500	3/8" Jiffy Clip (BX retainer clip)
120600	3/8" Greenfield (BX)
120800	1/4" In-Line Connector
120802	Red Butt Connector
120902	#74B Wire Nut
120903	Closed End Connector
121014	1/4" Insulated (female) Terminal
121499	5-1/2" Wire Tie
121500	8" Harness Tie
122804	Manometer (hydro gauge) for Measuring Gas Pressure
404502	White Brush-In-Cap Bottle Touch-Up Paint
404515	Coral Blue Brush-In-Cap Bottle Touch-Up Paint
404516	Ivory Brush-In-Cap Bottle Touch-Up Paint
882458	Tumbler Puller Assembly

