



# **ML-78**

# **Parts Manual**

---

---

**American Dryer Corporation**  
88 Currant Road  
Fall River, MA 02720-4781  
Telephone: (508) 678-9000 / Fax: (508) 678-9447  
E-mail: [techsupport@amdry.com](mailto:techsupport@amdry.com)

ADC Part No. 450181

# Retain This Manual In A Safe Place For Future Reference

American Dryer Corporation products embody advanced concepts in engineering, design, and safety. If this product is properly maintained, it will provide many years of safe, efficient, and trouble-free operation.

*ONLY properly licensed technicians should service this equipment.*

**OBSERVE ALL SAFETY PRECAUTIONS** displayed on the equipment or specified in the installation/operator's manual included with the dryer.

**WARNING: UNDER NO CIRCUMSTANCES should the door switch or the heat circuit devices ever be disabled.**

**WARNING: The dryer *must never* be operated with any of the back guards, outer tops, or service panels removed. PERSONAL INJURY or FIRE COULD RESULT.**

We have tried to make this manual as complete as possible and hope you will find it useful. ADC reserves the right to make changes from time to time, without notice or obligation, in prices, specifications, colors, and material, and to change or discontinue models.

## Important

For your convenience, log the following information:

DATE OF PURCHASE \_\_\_\_\_ MODEL NO. **ML-78** \_\_\_\_\_  
DISTRIBUTORS NAME \_\_\_\_\_  
Serial Number(s) \_\_\_\_\_  
\_\_\_\_\_  
\_\_\_\_\_

Replacement parts can be obtained from your distributor or the ADC factory. When ordering replacement parts from the factory, you can FAX your order to ADC at (508) 678-9447 or telephone your orders directly to the ADC Parts Department at (508) 678-9000. Please specify the dryer **model** and **serial numbers** in addition to the **description** and **part number**, so that your order is processed accurately and promptly.

The illustrations on the following pages may not depict your particular dryer exactly. The illustrations are a composite of the various dryer models. Be sure to check the descriptions of the parts thoroughly before ordering.

**“IMPORTANT NOTE TO PURCHASER”**

Information must be obtained from your local gas supplier on the instructions to be followed if the user smells gas. These instructions must be posted in a prominent location near the dryer.

# Table of Contents

Control Door Assembly .....	4
OPL Microprocessor Control Panel Assembly For models mfd. as of January 1, 2002 .....	5
Phase 6 OPL Microprocessor Control Panel Assembly .....	6, 7
Main Door Assembly (Round Door) .....	8, 9
Front Panel Assembly For models mfd. as of March 1, 2002 .....	10
Main Door Switch Assembly for Round Main Door .....	11
Sensor Bracket Assembly .....	12
Lint Trap Assembly .....	13
Lint Trap Assembly For models mfd. as of January 1, 2002 .....	14
Drop Lint Door Assembly .....	15
Drop Lint Door Assembly For models mfd. as of March 1, 2002 .....	16
Basket (Tumbler) Support Assembly .....	17
Idler Bearing Assembly .....	18, 19
Tumbler Bearing Assembly .....	20, 21
Single Phase Motor, Electric Relay Panel Assembly .....	22, 23
3-Phase Motor, Non-Reversing Electric Relay Panel Assembly .....	24, 25
3-Phase Motor, Reversing Electric Relay Panel Assembly .....	26, 27
Non-Reversing Totally Enclosed, Fan-Cooled (T.E.F.C.) Motor Mount Assembly .....	28, 29
Reversing Totally Enclosed, Fan-Cooled (T.E.F.C.) Motor Mount Assembly .....	30, 31
Hot Surface Ignition (HSI) Burner Assembly .....	32, 33
Sail Switch Assembly .....	34
Back Guard Assemblies .....	35
Additional Parts Available .....	36

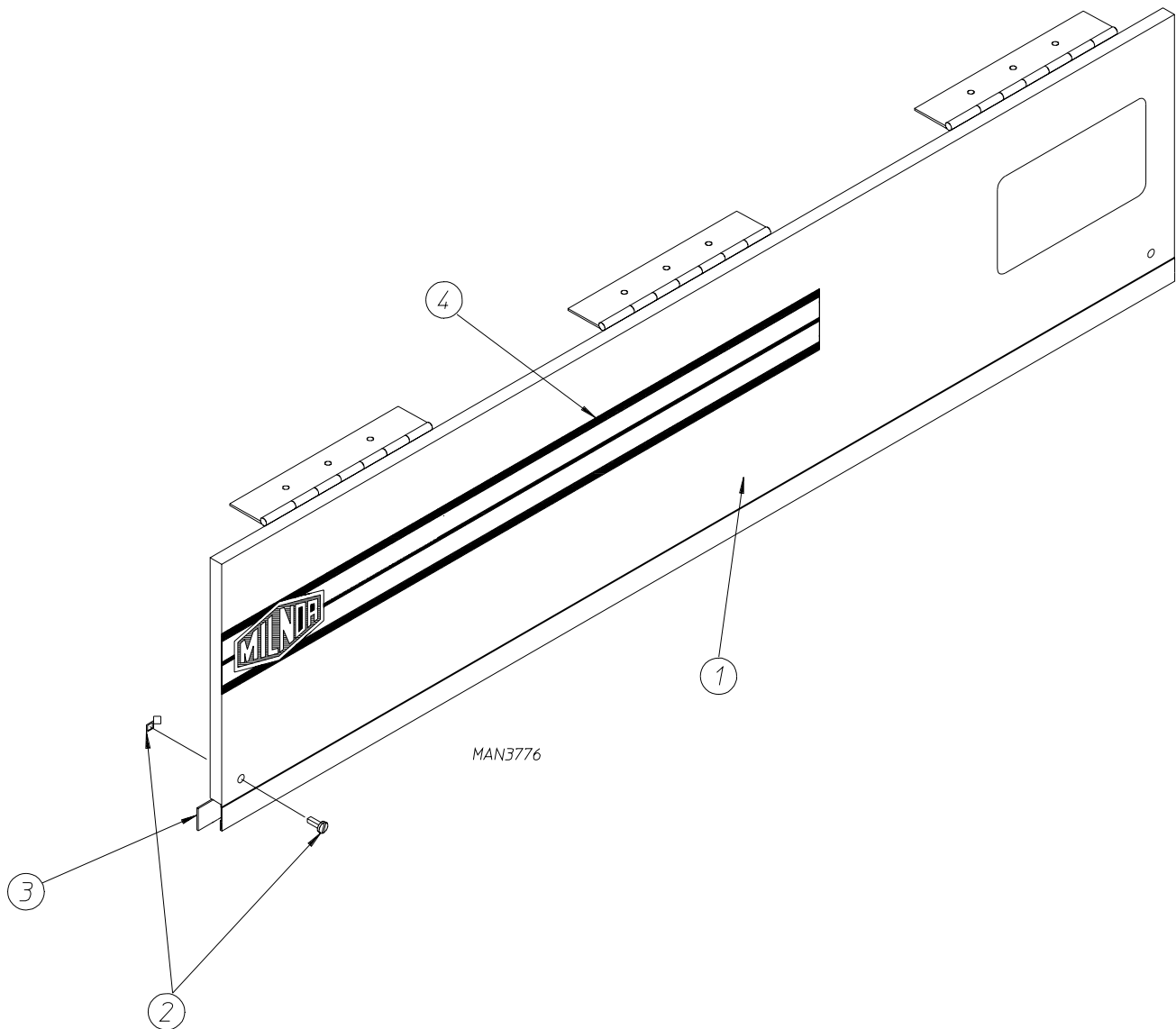

<u>Illus. No.</u>	<u>Part No.</u>	<u>Qty</u>	<u>Description</u>
1	881910	1	ML-78 Control Door Assembly White (includes illus. nos. 1 through 3)
	881911	1	ML-78 Control Door Assembly Blue (includes illus. nos. 1 through 3)
2	160005	2	Spring Turn Latch (2 piece)
3	117603	4	Noise Suppression Tape (sold by the foot)
4	112366	1	Milnor Logo ONLY

For Models Mfd. as of January 1, 2002

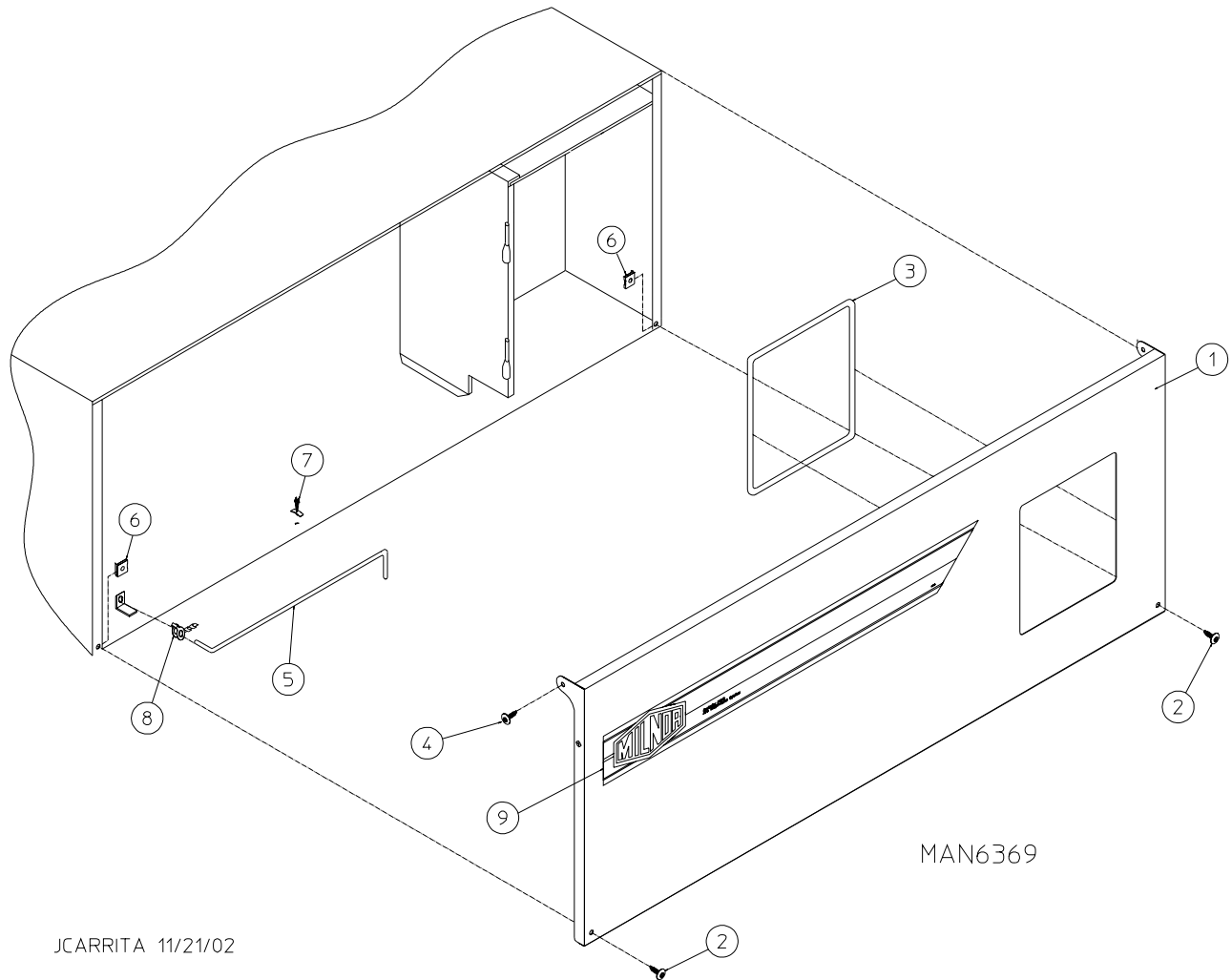

JCARRITA 11/21/02

<u>Illus. No.</u>	<u>Part No.</u>	<u>Qty.</u>	<u>Description</u>
1	801834	1	OPL Control Door (includes illus. nos. 1 and 3)
2	150321	2	#10-32 x 1/2" Phillips Machine Screw
3	117604	4	Noise Suppression Tape (sold by the foot)
4	150317	2	#10-16 x 3/4" TORX + BTN, Type 1
5	102503	1	Control Door Support Rod
6	154011	2	#10-32 Multi-Thread U-Nut
7	102602	1	Control Door Rod Support Latch
8	102601	1	Control Door Rod Retainer Clip
9	-----*	1	Logo Only

\* Contact reseller for logo.

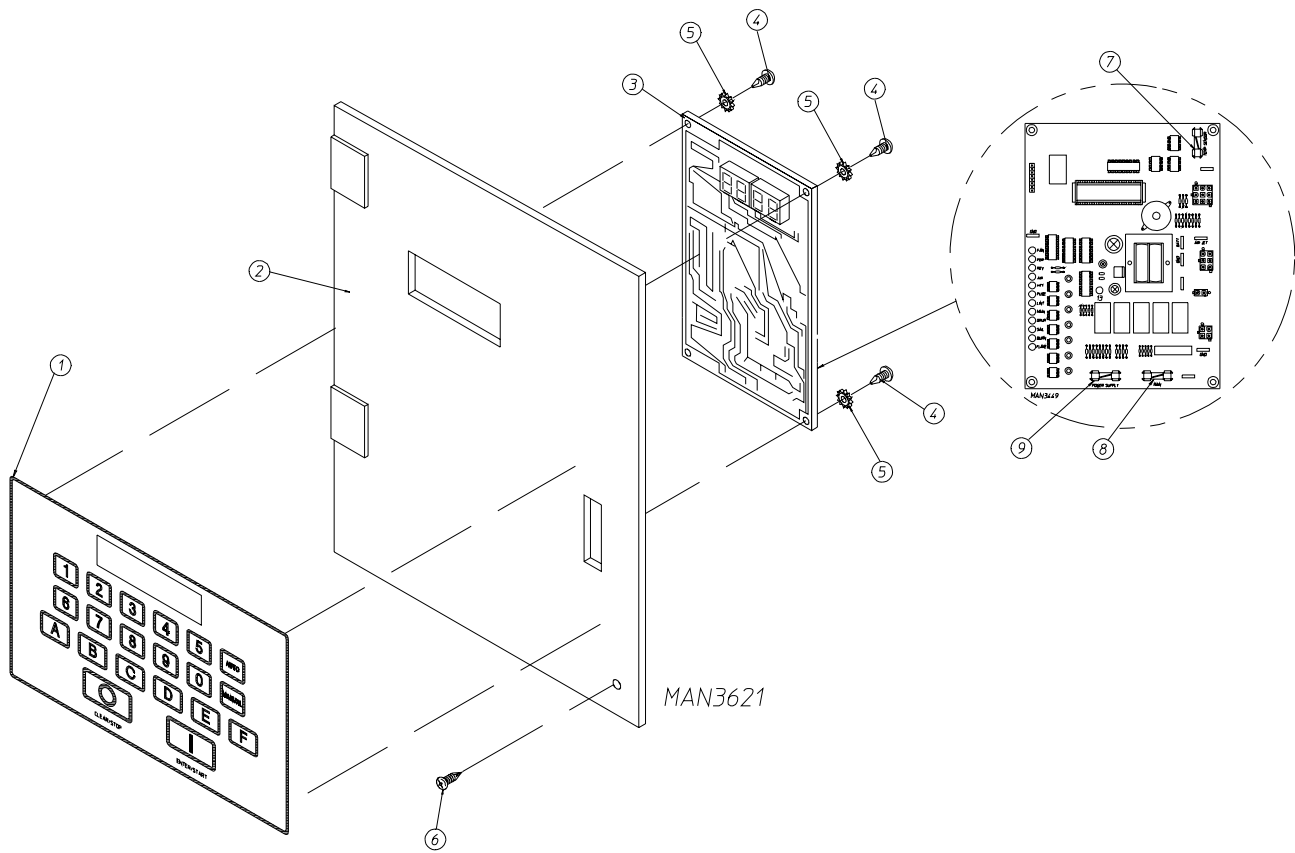

---

<u>Illus. No.</u>	<u>Part No.</u>	<u>Qty</u>	<u>Description</u>
1	112537	1	Phase 6 OPL Keypad
	112276	1	OPL Stick-on Labels (English Only) Not Illustrated
	112275	1	OPL Stick-on Labels (Spanish, Italian and Hebrew) Not Illustrated
	112277	1	3 Language OPL Stick-on Labels (English, Spanish and Hebrew) Not Illustrated
	112278	1	5 Language OPL Stick-on Labels (Italian, Dutch, French, German and Chinese) Not Illustrated
2	881745	1	Phase 6 Microprocessor (computer) Panel ONLY
	881747	1	Phase 6 OPL Non-Reversing Computer Panel Assembly Complete (includes illus. nos. 1 through 5 and 7 through 9)
	881746	1	Phase 6 OPL Reversing Computer Panel Assembly Complete (includes illus. nos. 1 through 5 and 7 through 9)
3	137123	1	Phase 6 OPL Non-Reversing Microprocessor Controller ONLY
	137122	1	Phase 6 OPL Reversing Microprocessor Controller ONLY
4	150005	2	#6-32 x 3/4" Phillips Round Head Machine Screw
5	153010	2	#6 Star Washer
6	150415	1	#10-32 x 1/2" Phillips Round Head Crimptite Screw
7	136048	1	1/8 Amp (Slo Blo) Fuse
8	136017	1	3.15 Amp (Fast Acting) Fuse
9	136019	1	1 Amp (Fast Acting) Fuse

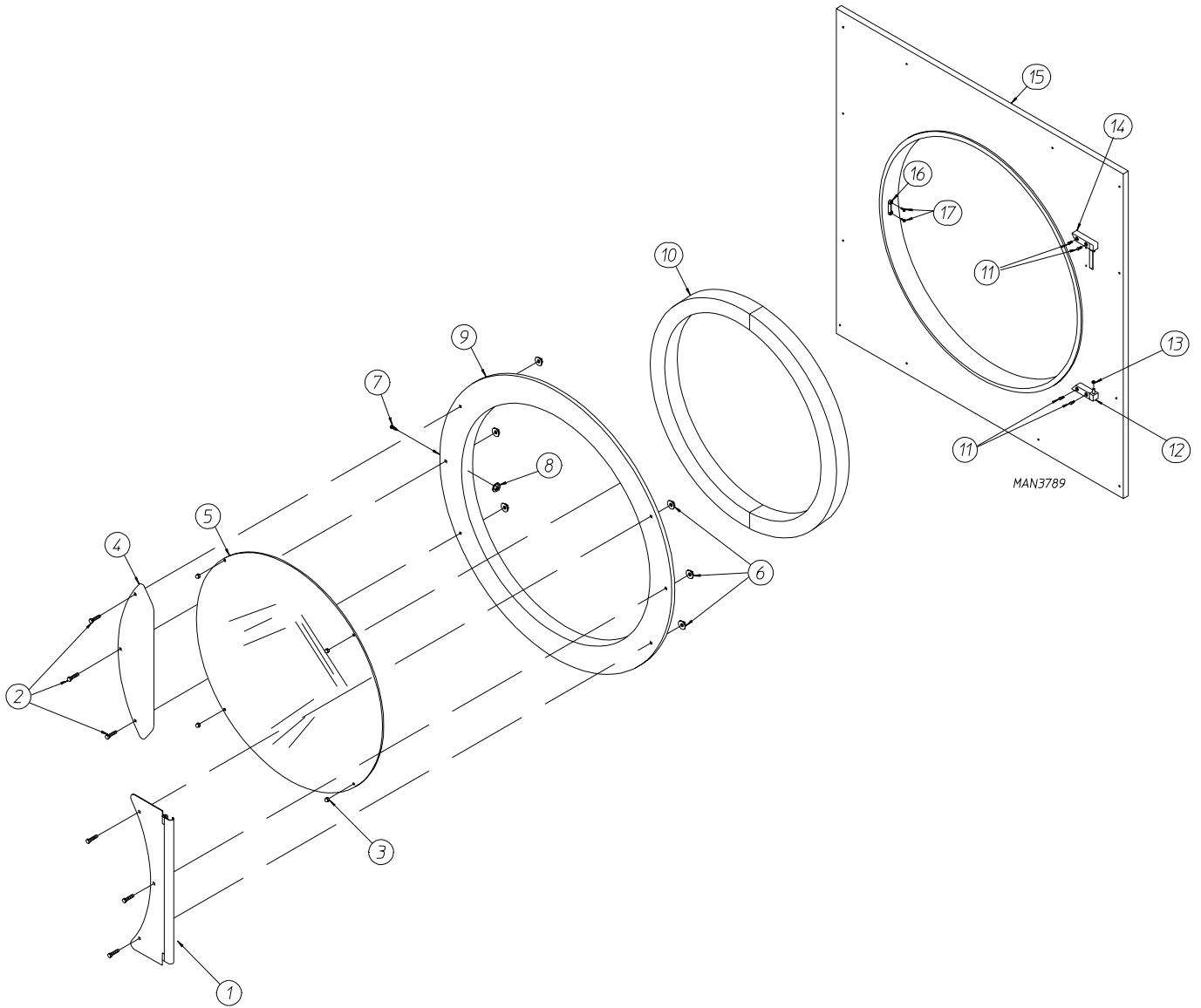



<u>Illus. No.</u>	<u>Part No.</u>	<u>Qty</u>	<u>Description</u>
1	881685	1	White Main Door Hinge
	881757	1	Blue Main Door Hinge
2	881740	6	1/4-20 x 5/8" (white) Carriage Bolt
	881739	6	1/4-20 x 5/8" (blue) Carriage Bolt
3	151012	4	#10-32 White Nylon Acorn Nut
	151014	4	#10-32 Blue Nylon Acorn Nut
4	881688	1	White CRS Main Door Handle
	881737	1	Blue CRS Main Door Handle
5	102213	1	29-7/8" Door Glass
	170730	1	Door Glass Adhesive (10.3 oz cartridge)
6	881806	6	1/4-20 Free Spin Wash Nut (white)
	881807	6	1/4-20 Free Spin Wash Nut (blue)
7	150120	1	Main Door Latch Screw
8	151010	1	#10-32 Hex Acorn Nut (black)
9	881689	1	White Main Door Assembly Complete (includes illus. nos. 1 through 10)
	881738	1	Blue Main Door Assembly Complete (includes illus. nos. 1 through 10)
	881684	1	White Main Door Ring
	881756	1	Blue Main Door Ring
10	102356	1	97-1/2" Main Door Gasket
11	150443	2	1/4-20 x 3/4" Stainless Steel Cap Screw
12	881441	1	White Bottom Hinge Block (includes illus. nos. 11 and 12)
	881735	1	Blue Bottom Hinge Block (includes illus. nos. 11 and 12)
13	153031	1	Nylon Washer
14	881440	1	White Top Hinge Block (includes illus. nos. 11 and 14)
	881736	1	Blue Top Hinge Block (includes illus. nos. 11 and 14)
15	882057	1	White Front Panel Assembly (includes illus. nos. 15-17)
	882058	1	Blue Front Panel Assembly (includes illus. nos. 15-17)
16	170330	1	Friction Door Catch
17	154215	2	5/32" Pop Rivet

For Models Mfd. as of March 1, 2002

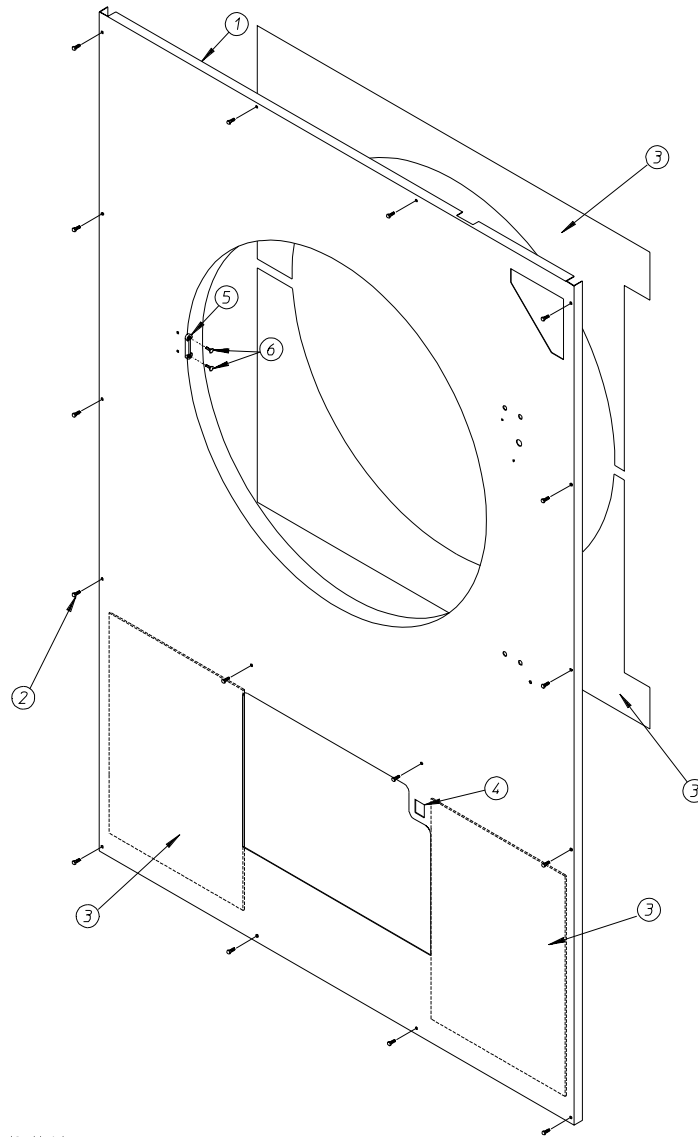

ST 12/11/01

MAN6031

<u>Illus. No.</u>	<u>Part No.</u>	<u>Qty.</u>	<u>Description</u>
1	883246*	1	Right Hand Front Panel Assembly (for Non-Coin models) (includes illus. nos. 1, 3, 5, and 6)
2	150313	14	#10-16 x 1/2" TORX + BTN, Type 1
	150318	**	25 IP Stick-Fit TORX + Bit...Not Illustrated
3	116147	2	13" x 18-1/2" Rear Lower Wall Insulation
	116320	1	Top Front Panel Insulation
	116321	1	Bottom Front Panel Insulation
4	122002	1	Lint Drawer Switch
5	881987	1	Friction Door Latch Kit (includes illus. nos. 5 and 6)
6	154215	2	5/32" Pop Rivet

\* Specify color when ordering.

\*\* As needed.

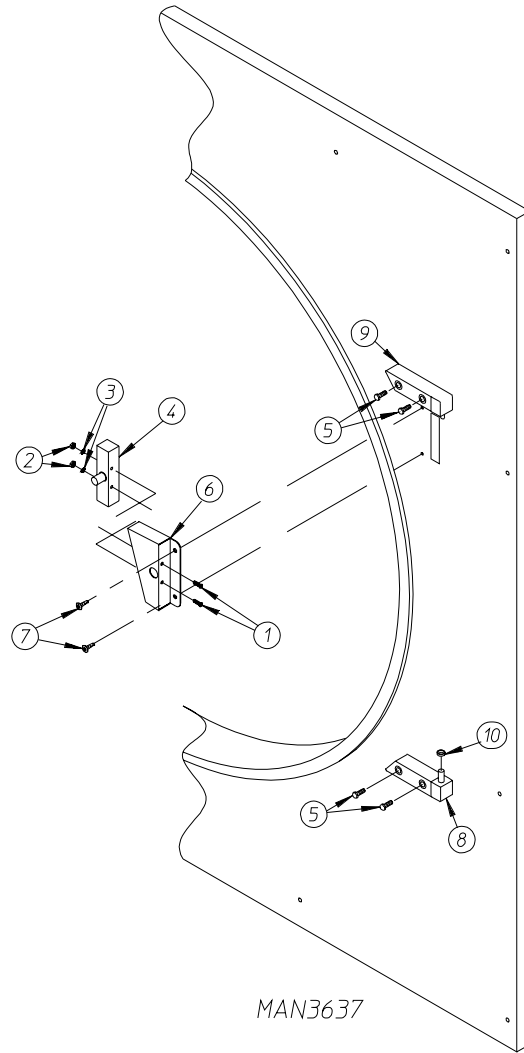

<u>Illus. No.</u>	<u>Part No.</u>	<u>Qty</u>	<u>Description</u>
1	150006	2	#6-32 x 7/8" Phillips Pan Head Machine Screw
2	152013	2	#6-32 Hex Nut
3	153010	2	#6 Star Washer
4	137005	1	Single Pole Door Switch
5	150443	4	1/4-20 x 3/4" Stainless Steel Cap Screw
6	881687	1	White Main Door Switch Housing ONLY
	881695	1	Blue Main Door Switch Housing ONLY
	881702	1	White Main Door Switch with Housing Assembly (includes illus. nos. 1 through 4 and 6)
	881700	1	Blue Main Door Switch with Housing Assembly (includes illus. nos. 1 through 4 and 6)
7	150301	2	#8-18 x 7/16" Phillips Pan Head TEK Screw
8	881441	1	White Bottom Hinge Block (includes illus. nos. 5 and 8)
	881735	1	Blue Bottom Hinge Block (includes illus. nos. 5 and 8)
9	881440	1	White Top Hinge Block (includes illus. nos. 5 and 9)
	881736	1	Blue Top Hinge Block (includes illus. nos. 5 and 9)
10	153031	1	Nylon Washer

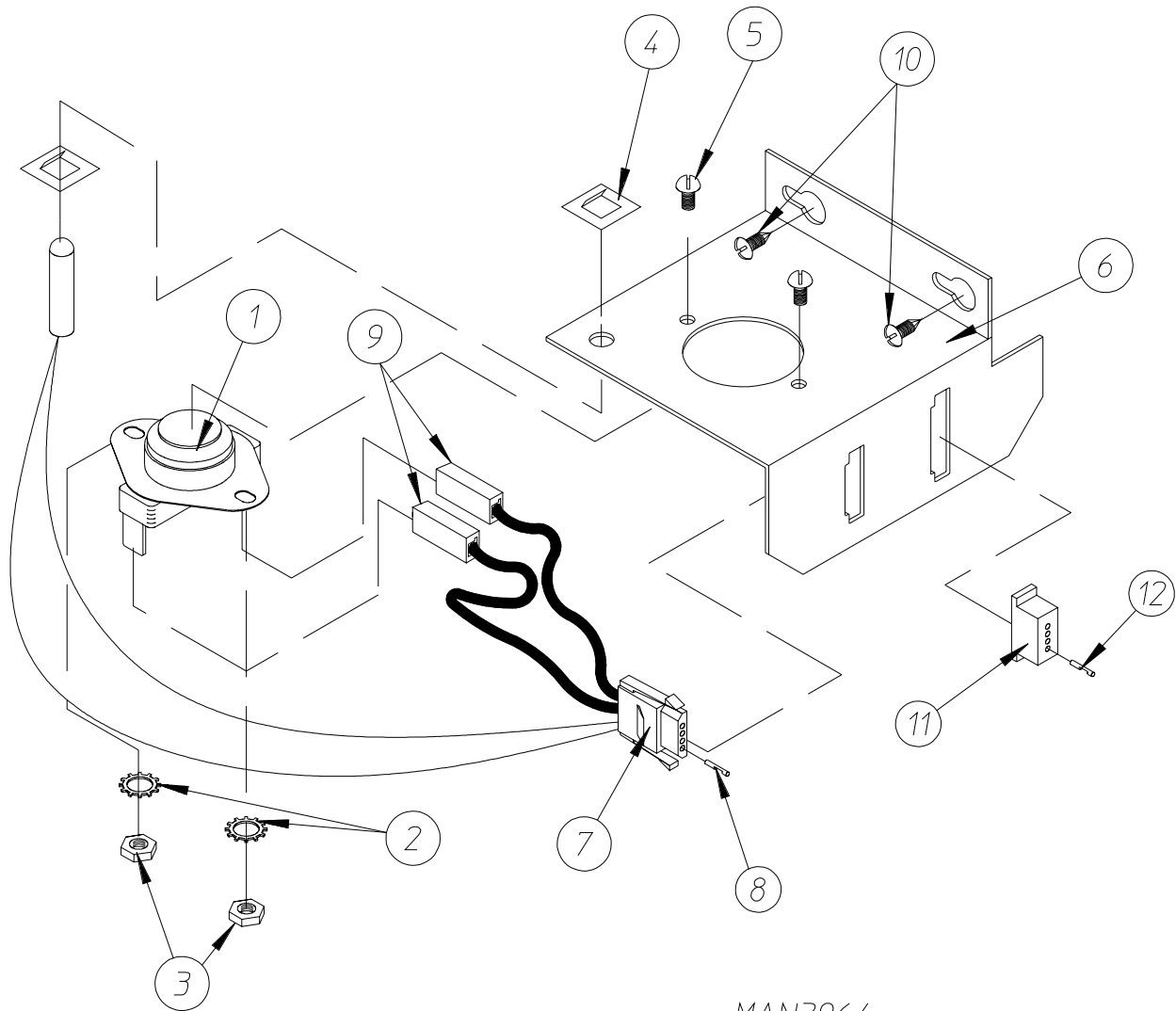

MAN3964

<u>Illus. No.</u>	<u>Part No.</u>	<u>Qty</u>	<u>Description</u>
1	130103	1	225° F Large Automatic Thermostat ONLY
2	153010	2	#6 Star Washer
3	152000	2	#6-32 Hex Nut
4	154007	2	1/4" Tinnerman Push On Fastener
5	150005	2	#6-32 x 1/4" Phillips Round Head Machine Screw
6	881912	1	ML-78 Temperature Sensor Bracket Complete (includes illus. nos. 1-7)
7	880251	1	1/4" Temperature Sensor Probe Assembly (includes illus. nos. 7 through 9)
	122605	1	4 Pin Socket Connector
8	122701	4	Socket Terminal ONLY
9	121028	2	Insulated Terminal ONLY
10	150301	2	#8-18 x 7/16" Phillips Pan Head TEK Screw
11	122604	1	4 Pin Connector ONLY
12	122700	4	Pin Terminal ONLY
	122801	1	Pin/Socket Extraction Tool (for removal of illus. no. 8 and 12)

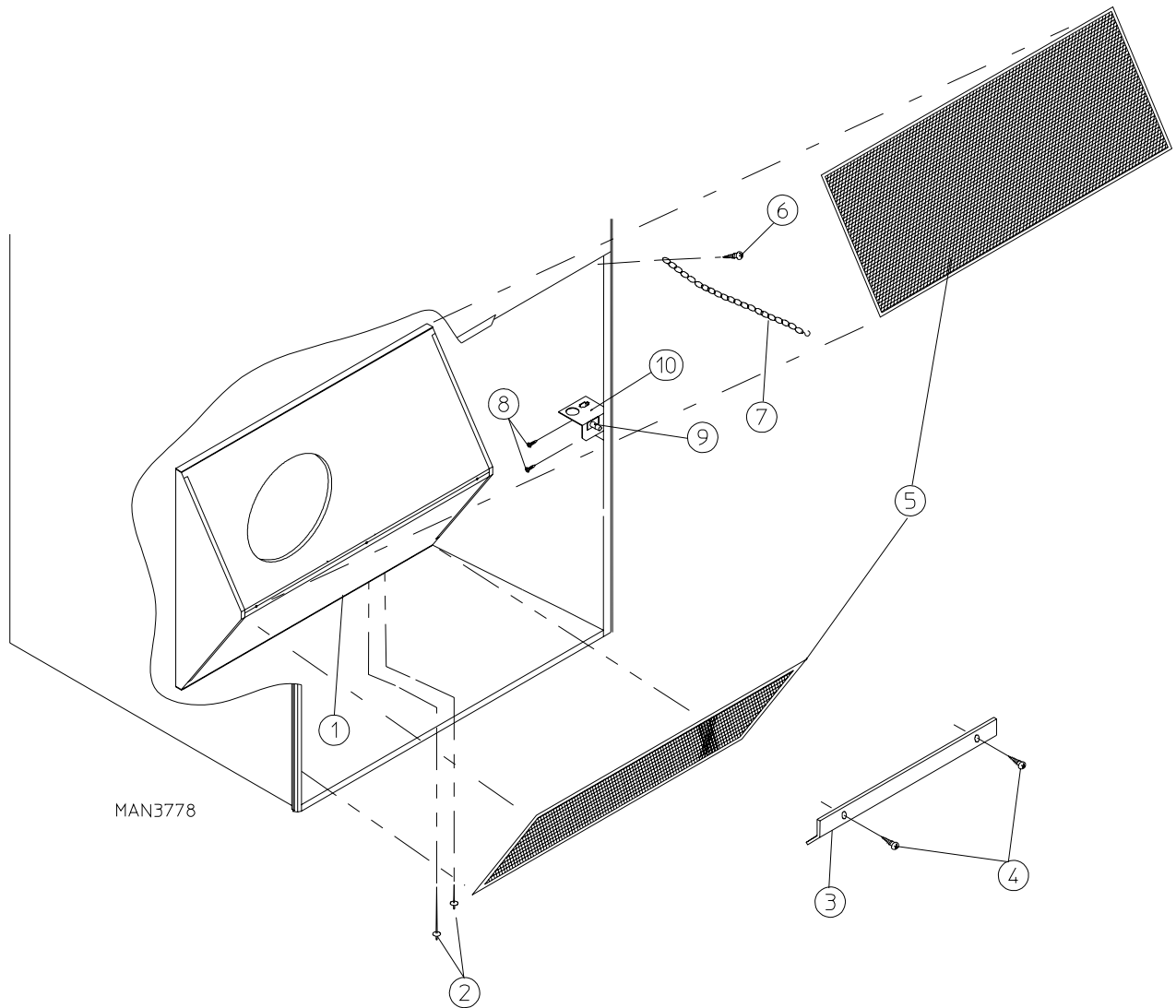

MAN3778

<u>Illus. No.</u>	<u>Part No.</u>	<u>Qty</u>	<u>Description</u>
1	881904	1	Lint Coupe Assembly Complete (includes illus. nos. 1, 3 through 5)
	801767	1	Lint Coupe ONLY
2	154200	7	5/32" Pop Rivet
3	304100	1	Lint Screen Hold Down
4	150300	3	#10 x 1/2" Hex Washer TEK Screw
5	800500	2	Lint Screen
6	150419	2	#6 x 1/2" Tamper Proof TEK Screw
7	108120	1	Chain for Drop Lint Door
	150418	1	Tamper Proof Screw Hand Driver
8	150425	2	#12-24 x 3/8" Phillips Round Head Screw
9	122116	1	Lint Drawer Switch ONLY
10	323724	1	Lint Drawer Switch Bracket

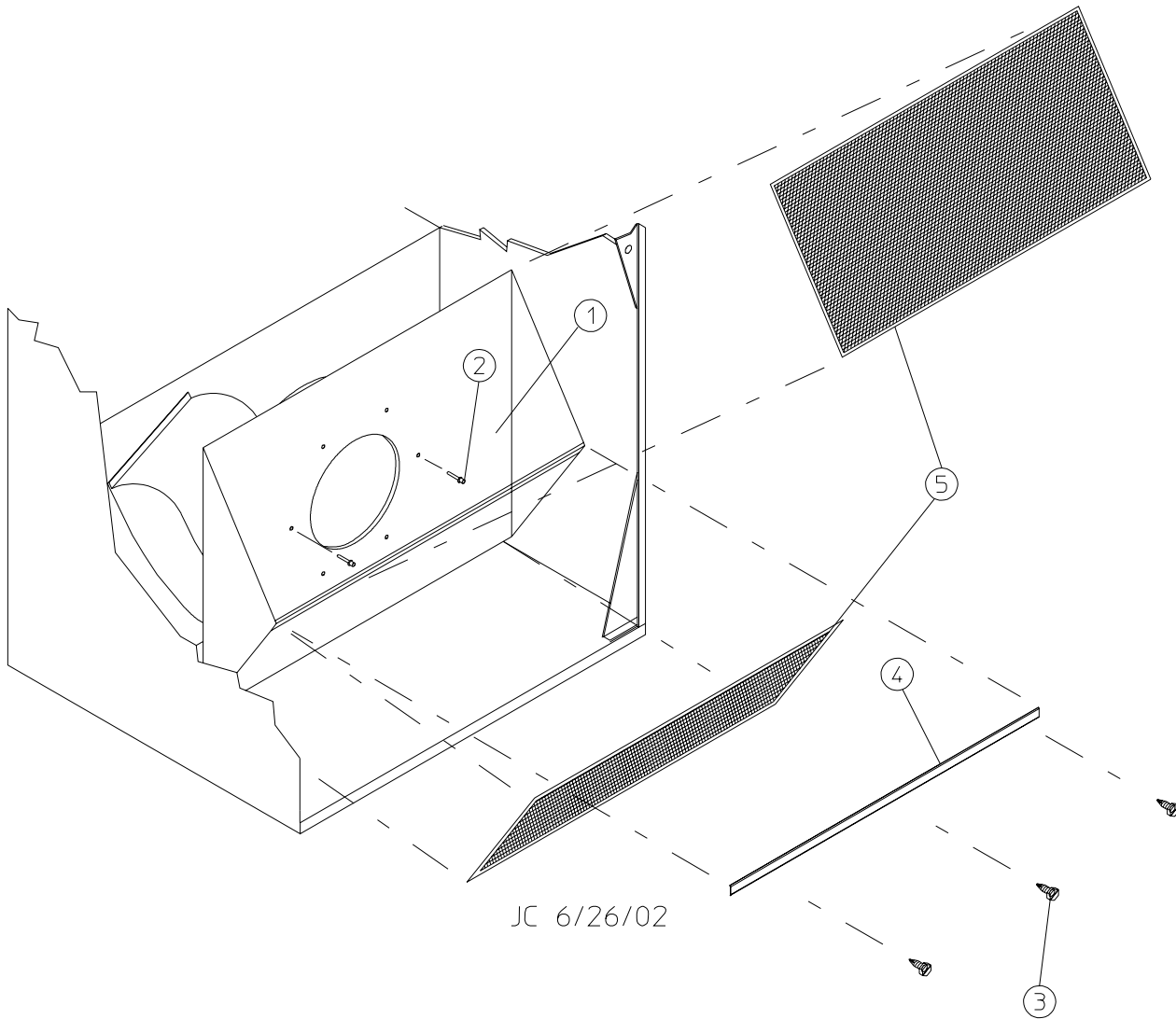

MAN6192

<u>Illus. No.</u>	<u>Part No.</u>	<u>Qty.</u>	<u>Description</u>
1	802833	1	Lint Trap Assembly Complete (includes illus. nos. 1 and 3 through 5)
	802834	1	Lint Trap Only
2	154200	6	5/32" Pop Rivet
3	150300	3	#10-16 x 1/2" Hex Washer TEK Screw
4	304100	1	Lint Screen Holder Only
5	800500	2	Lint Screen Assembly

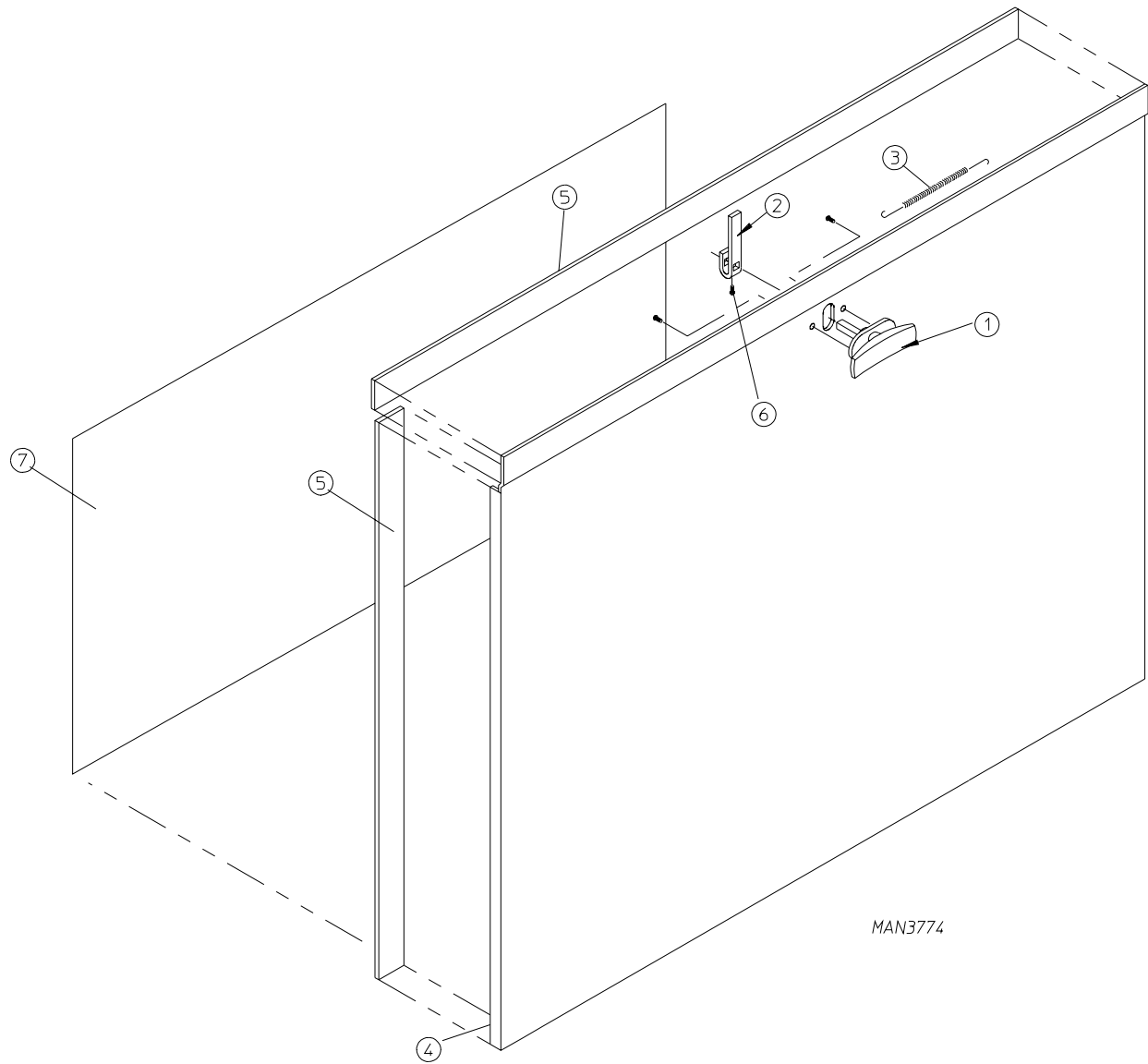

<u>Illus. No.</u>	<u>Part No.</u>	<u>Qty</u>	<u>Description</u>
1	800150	1	Knob Latch Kit Assembly (includes illus. nos. 1 and 2)
	160200	1	Knob Latch ONLY with 2 (two) screws (without cam)
2	160009	1	Knob Latch Adjustable Cam ONLY
3	157000	1	Drop Lint Door Spring
4	881906	1	ML-78 White Insulated Drop Lint Door Assembly (includes illus. nos. 4, 5 and 7)
	881907	1	ML-78 Blue Insulated Drop Lint Door Assembly (includes illus. nos. 4, 5 and 7)
5	117600	7	Noise Suppressor Tape (sold in feet)
6	150425	1	#12-24 x 3/8" Round Head Machine Screw ONLY (screw for knob latch adjustable cam)
7	116322	1	Lint Door Insulation

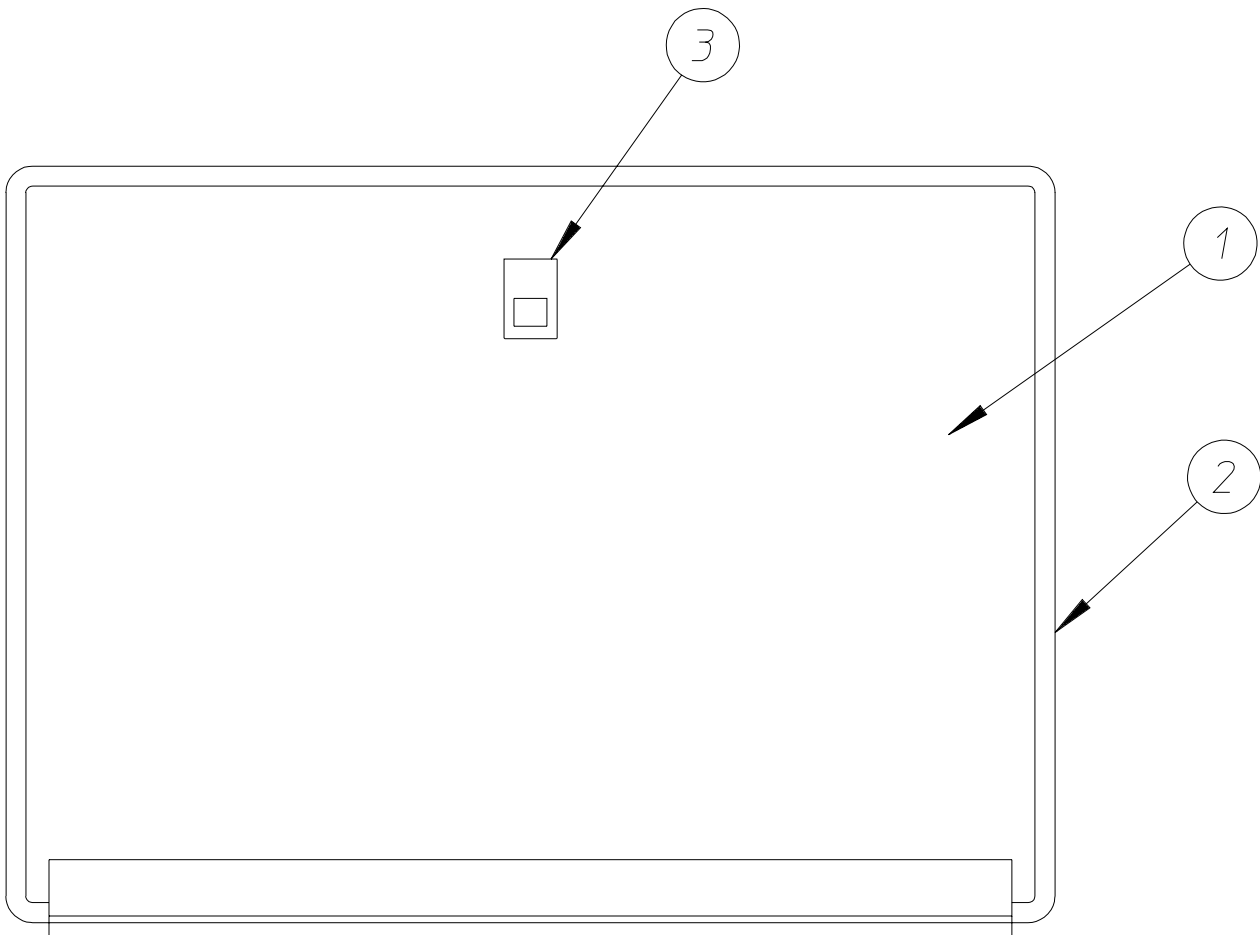

ST 12/11/01

MAN6030

<u>Illus. No.</u>	<u>Part No.</u>	<u>Qty.</u>	<u>Description</u>
1	883680*	1	White Drop Lint Door Assembly (includes illus. nos. 1 through 3)
2	117604	5	Noise Suppression Tape (sold by the foot)
3	170226	1	Slide Latch

\* Specify color if other than white.



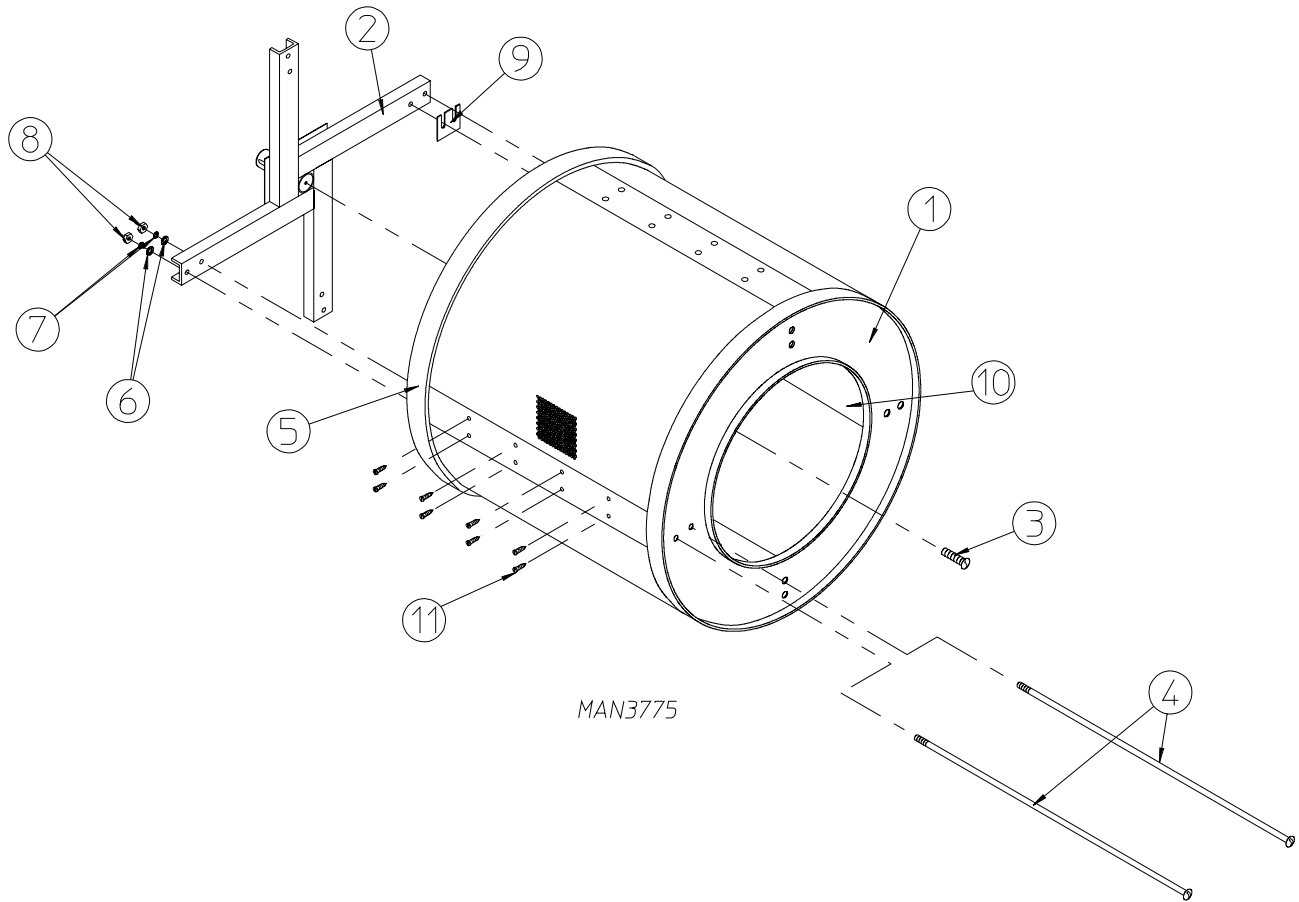

<u>Illus. No.</u>	<u>Part No.</u>	<u>Qty</u>	<u>Description</u>
1	801751	1	Basket (tumbler) ONLY Without Felt Collar
	801773	1	ML-78 Basket (tumbler) and Support Assembly Complete (includes illus. nos. 1 through 11)
2	801774	1	Tumbler Support ONLY
3	150500	1	5/16-18 x 3/4" Socket Buttonhead Screw
4	100912	8	1/2"-13 x 25-3/8" Tie Rod
5	116006	1	Felt Collar
	170730	1	Felt Collar Adhesive (10.3 oz.)
6	153011	8	1/2" Flat Washer
7	153026	8	1/2" Lock Washer
8	152011	8	1/2-13 Hex Nut
9	301701	*	Tumbler Shims
10	314701	4	Tumbler Ribs
11	150413	32	#10-16 x 1/2" TORX Crimp-tite Screws

\* As Required

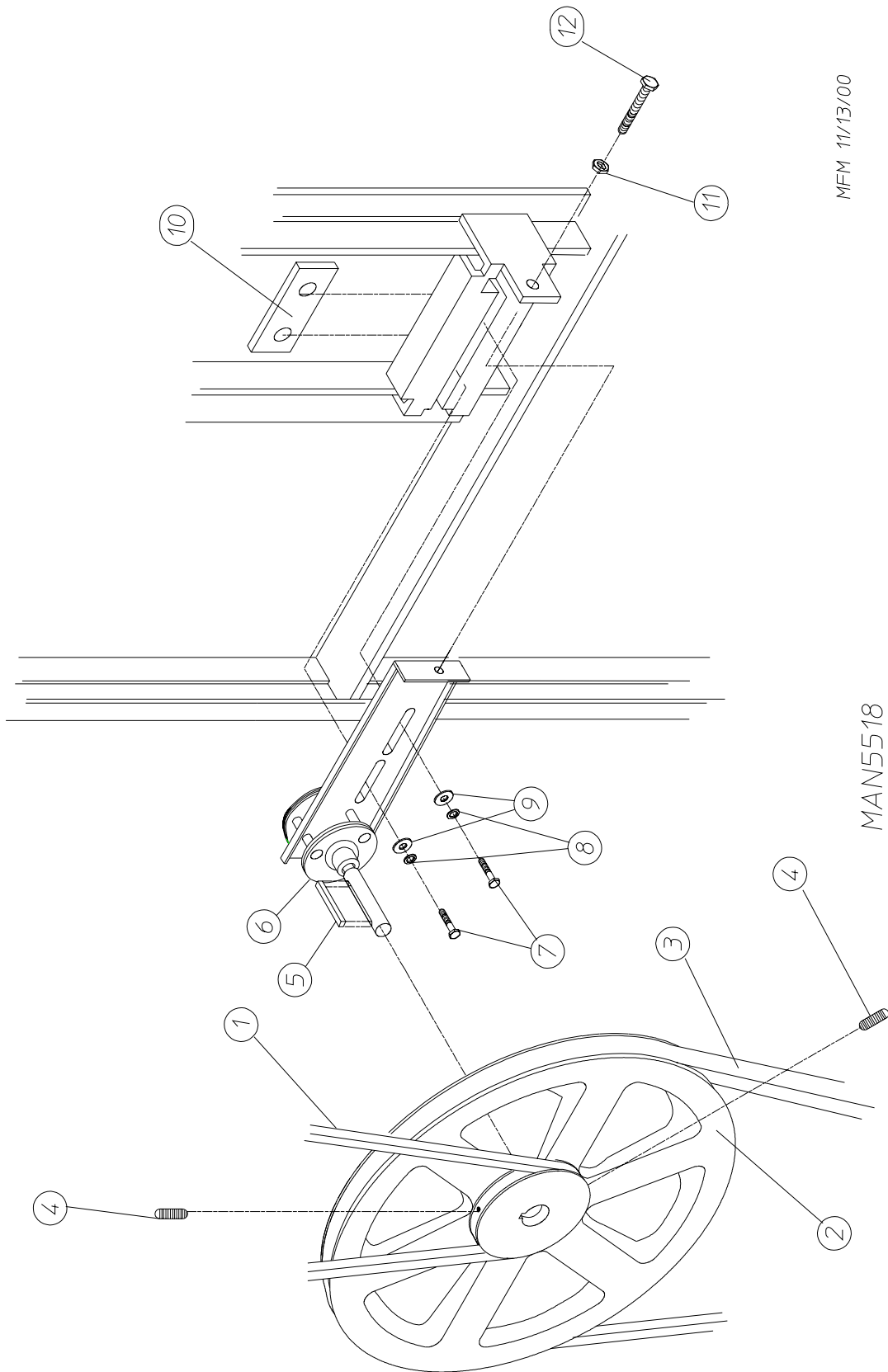

MFEM 11/13/00

MAN5518

---

<u>Illus. No.</u>	<u>Part No.</u>	<u>Qty.</u>	<u>Description</u>
1	100185	1	5L-780 V-Belt (idler to basket [tumbler])
2	101140	1	14" x 3" Compound Pulley
3	100178	1	4L-570 V-Belt (idler to motor)
4	154301	2	5/16-18 x 1" Allen Set Screw
5	100705	1	3/16" x 3/16" x 1-3/8" Key
6	883473	1	Idler Bearing Assembly Complete (includes illus. nos. 5 through 17)
7	150617	2	3/8-16 x 1" Hex Head Machine Bolt
8	153005	2	3/8" Lock Washer
9	153004	2	3/8" Flat Washer
10	801009	1	Idler Square Washer
11	152005	1	3/8"-18 Hex Nut
12	150623	1	3/8"-16 x 5" Hex Head Machine Bolt

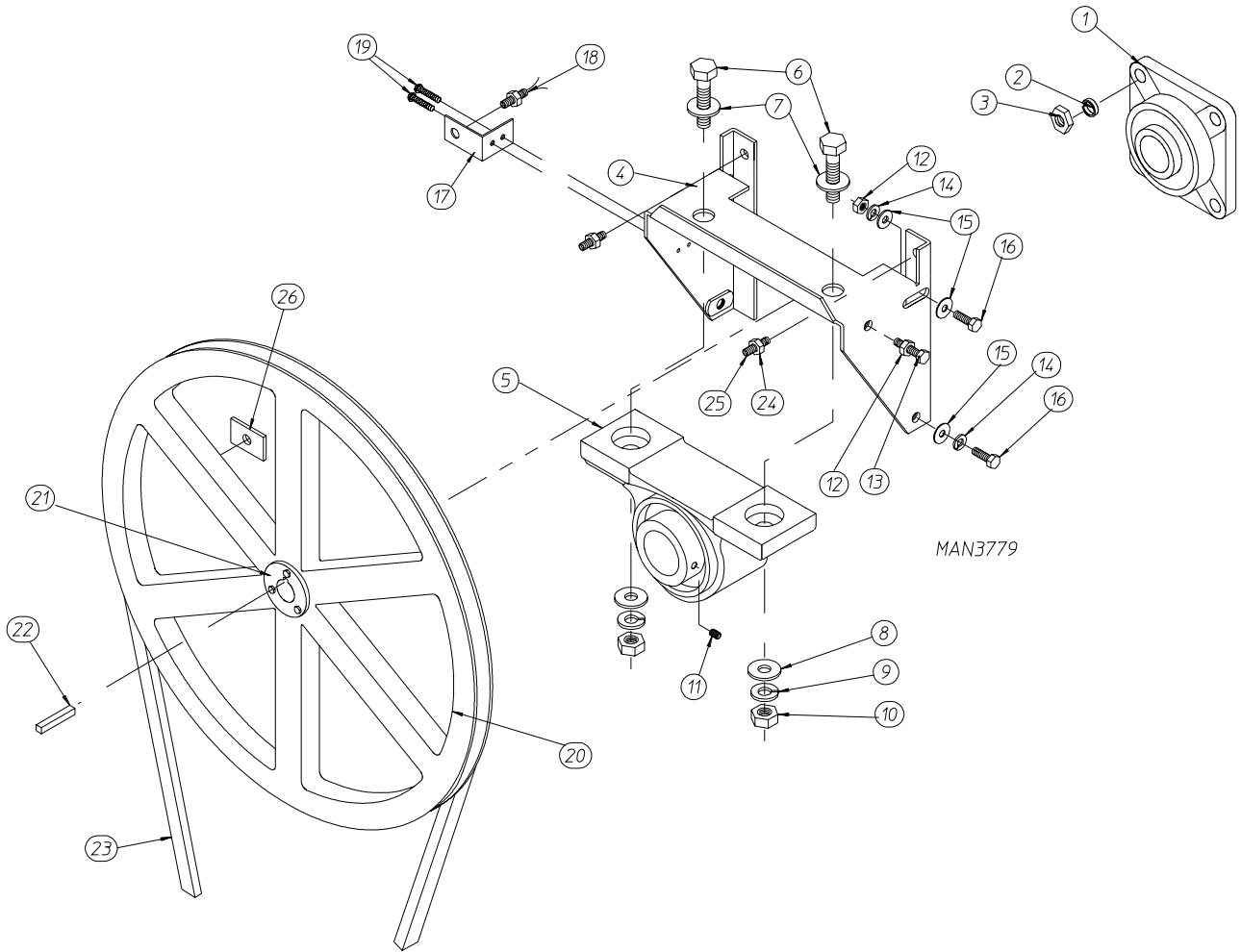

<u>Illus. No.</u>	<u>Part No.</u>	<u>Qty</u>	<u>Description</u>
1	100244	1	1-15/16" Flange Bearing
2	153025	4	Lock Washer
3	152050	4	Hex Nut
4	801775	1	Pillow Block Bearing Assembly Complete (includes illus. nos. 4 through 13)
	801761	1	Pillow Block Bearing Housing ONLY
5	100245	1	1-15/16" Pillow Block Bearing
6	150633	2	1/2"-13 x 2-1/4" Hex Head Bolt
7	153011	2	9/16" Flat Washer
8	153011	2	9/16" Flat Washer
9	153026	2	1/2" Lockwasher
10	152011	2	1/2"-13 Hex Nut
11	154322	2	3/8-24 x 7/16 Setscrew
12	152004	2	5/16-18 Hex Nut
13	150621	2	5/16-18 x 1-1/2" Allen Setscrew
14	153002	4	5/16" Lock Washer
15	153001	6	5/16" Flat Washer
16	150621	4	5/16-18 x 3/4" Hex Bolt
17	314746	1	Rotational Sensor Bracket (option)
18	824807	1	Rotational Sensor Assembly (option)
19	150413	2	#10-16 x 1/2" Phillips Hex Head TEK Crimptite
20	882111	1	18" Pulley with rotation sensor magnet (option)
21	101220	1	1-15/16" Taper Lock Bushing
22	100719	1	1/2" x 1/2" x 1-3/8 Key
23	100135	1	AP-74 V-Belt
24	152004	2	5/16-18 Hex Nut
25	150610	2	5/16-18 x 1-1/2" Allen Setscrew
26	102102	1	Rotational Sensor Magnet (option)
	401010	1	Adhesive for Magnet

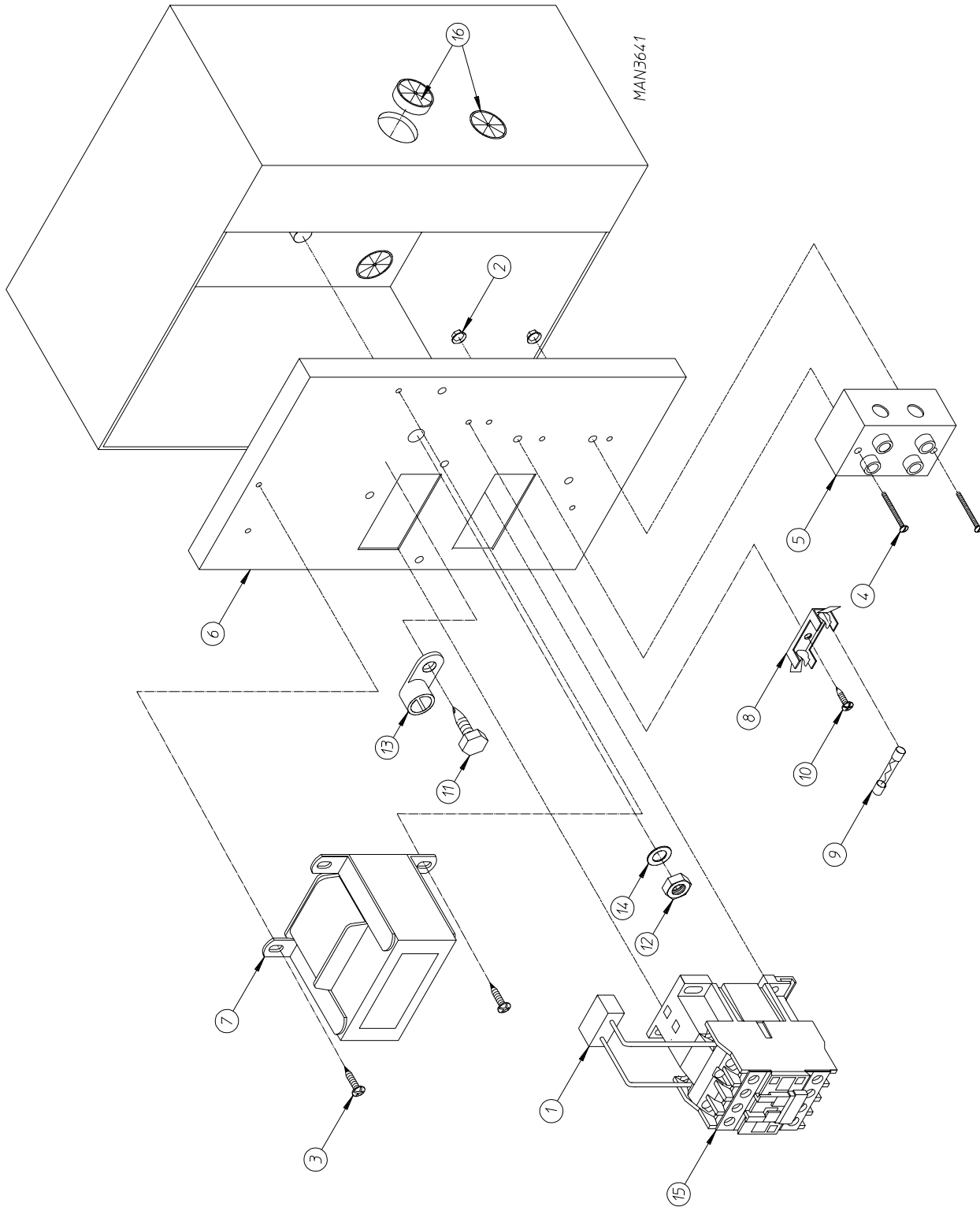

---

<u>Illus. No.</u>	<u>Part No.</u>	<u>Qty</u>	<u>Description</u>
1	137015	1	RC Network
2	151000	2	#6-32 Pal Nut
3	150300	2	#10 x 1/2" Hex Washer TEK Screw
4	150008	2	#6-32 x 1 1/4" Phillips Round Head Machine Screw
5	120716	1	2 Position Terminal Block
6	306304	1	Electric Relay Panel Mounting Plate ONLY
7	132083	1	Step Down Transformer ( <i>for 120/240 Volt 1Ø Only</i> )
	881763	1	Termination kit
8	136008	*	Fuse Holder ONLY
9	136049	1	3/4 Amp (Slo Blo) Fuse ( <i>for 120 Volt Models Only</i> )
	136057	2	1/2 amp (Slo Blo) fuse ( <i>for 208/240 Volt Only</i> )
10	150301	*	#8-18 x 7/16" Phillips Pan Head TEK Screw
11	150297	1	#10 x 1/2" Hex Washer TEK Screw - Green
12	152004	1	5/16-18 Hex Nut
13	121010	1	L-70 Ground Lug
14	153002	1	5/16" Lock Washer
15	132445	1	3-Pole Contactor - 24 VAC
16	121300	3	Open/Closed Bushing

\* As Required

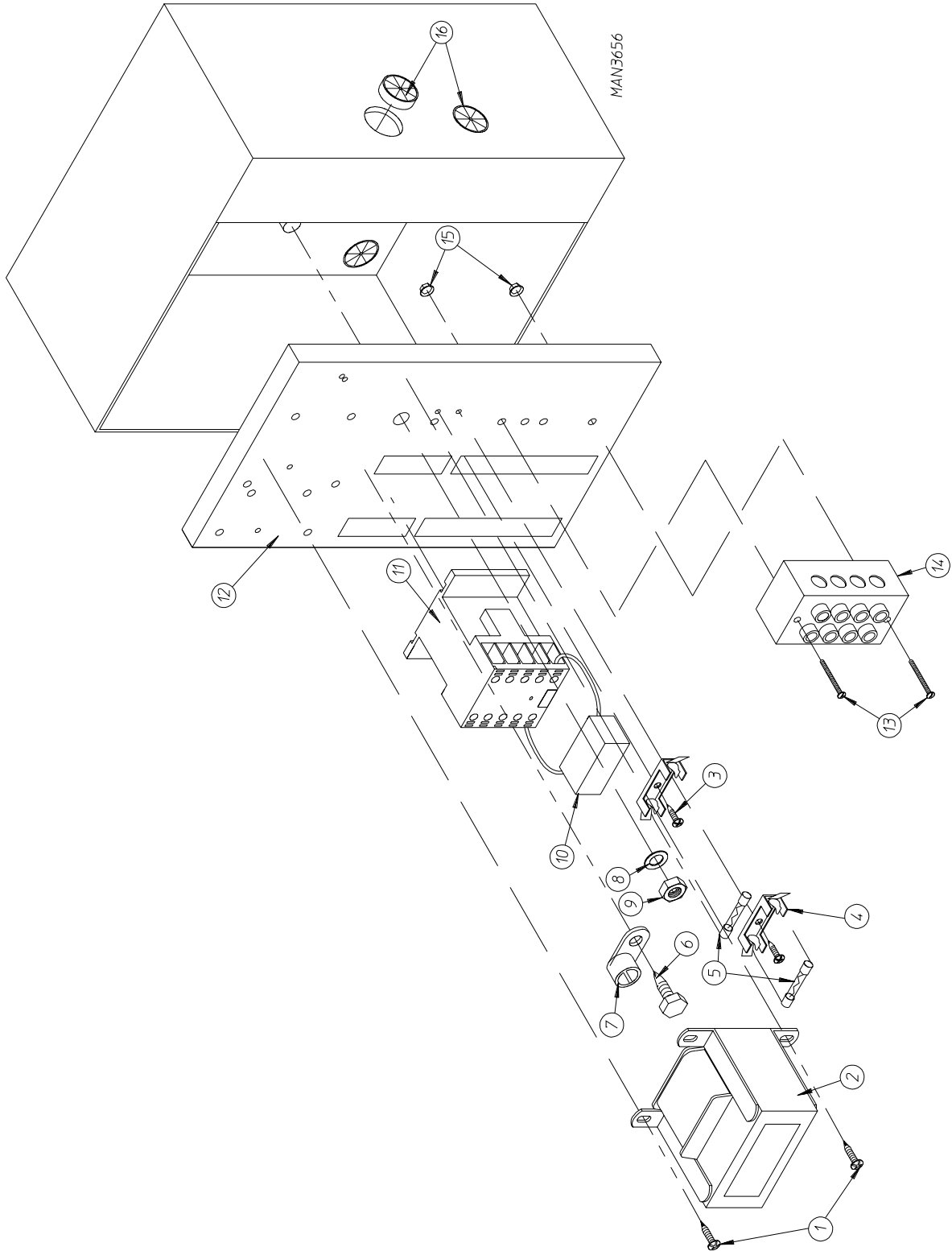



---

<u>Illus. No.</u>	<u>Part No.</u>	<u>Qty</u>	<u>Description</u>
1	150300	2	#10 x 1/2" Hex Washer TEK Screw
2	132083	1	Step Down Transformer ( <i>for 208/240 volts Only</i> )
	881763		Termination Kit
3	150301	2	#8-18 x 7/16" Phillips Pan Head TEK Screw
4	136008	2	Fuse Holder ONLY
5	136057	2	1/2 Amp (Slo Blo) Fuse
6	150297	1	#10 x 1/2" Hex Washer TEK Screw - green
7	121010	1	L-70 Ground Lug
8	153002	1	5/16" Lock Washer
9	152004	1	5/16-18 Hex Nut
10	137015	1	RC Network
11	132447	1	3-Pole Contactor - 24 VAC
12	322812	1	Electric Relay Panel Mounting Plate ONLY
13	150008	2	#6-32 x 1-1/4" Phillips Round Head Machine Screw
14	120701	1	4-Position Terminal Block
15	151000	2	#6-32 Pal Nut
16	121300	3	Open/Closed Bushing

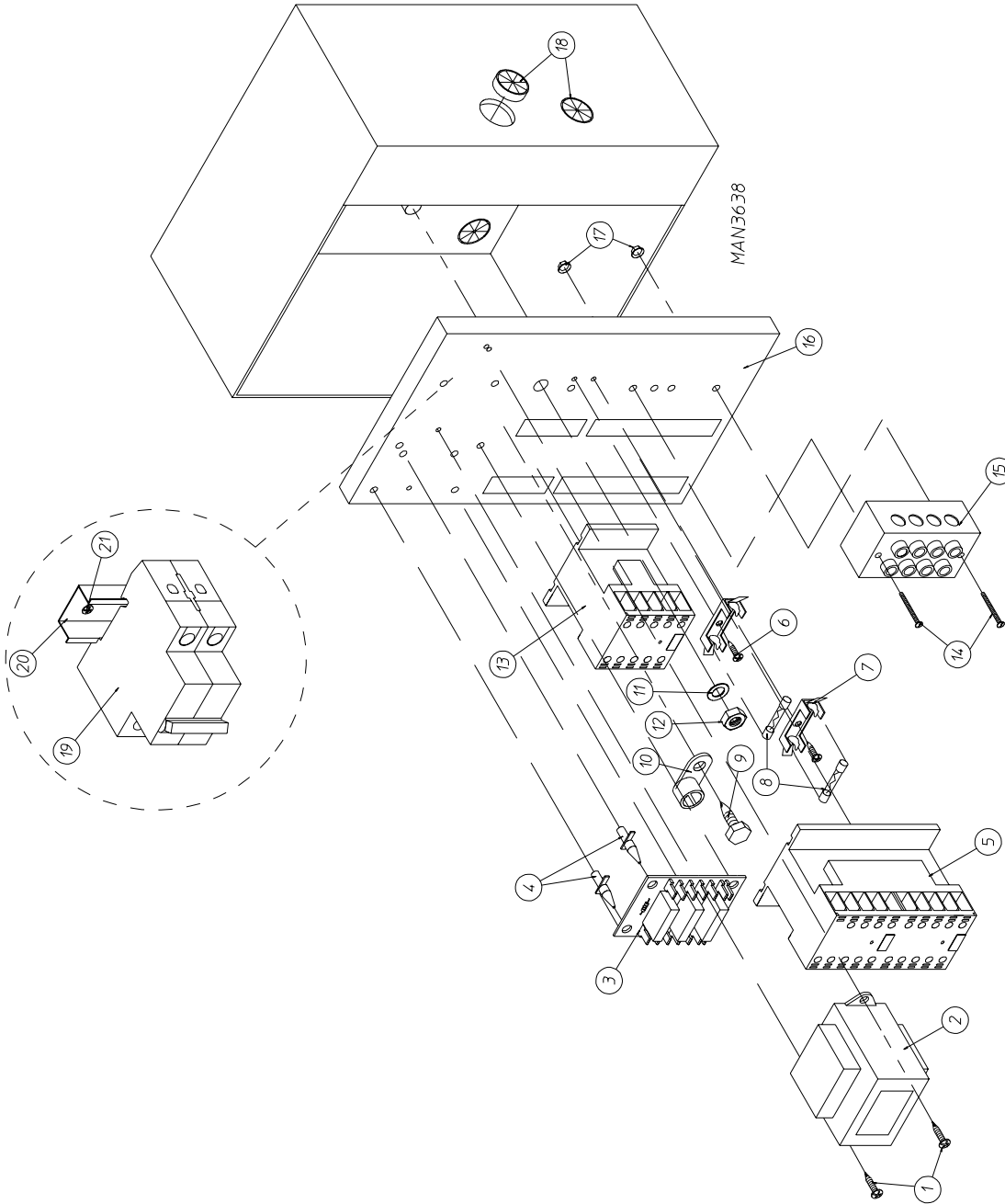

<u>Illus. No.</u>	<u>Part No.</u>	<u>Qty</u>	<u>Description</u>
1	150300	2	#10 x 1/2" Hex Washer TEK Screw
2	132083	1	Step Down Transformer ( <i>for 208/230 volts Only</i> )
	881763	1	Termination Kit
3	137060	1	Arc Suppressor (A.S.) Board
4	137013	4	Nylon Standoff
5	132448	1	Reversing Contactor ( <i>208/230/240/380/460 volt</i> ) 24 VAC
6	150301	2	#8-18 x 7/16" Phillips Pan Head TEK Screw
7	136008	2	Fuse Holder ONLY ( <i>for 208-230/240 volt models Only</i> )
8	136057	2	1/2 Amp (Slo Blo) Fuse ( <i>for 208-230/240 volt models Only</i> )
9	150297	1	#10 x 1/2" Hex Washer TEK Screw - Green
10	121010	1	L-70 Ground Lug
11	153002	1	5/16" Lock Washer
12	152004	1	5/16-18 Hex Nut
13	132447	1	3-Pole Contactor - 24 VAC
14	150008	2	#6-32 x 1/4" Phillips Round Head Machine Screw
15	120701	1	4-Position Terminal Block
16	322812	1	Electric Relay Panel Mounting Plate ONLY
17	151000	2	#6-32 Pal Nut
18	121300	3	Open/Closed Bushing
19	135501	1	1 Amp Double Pole Circuit Breaker ( <i>for 460/480 volt models Only</i> )
20	120768	2	Din Mounting Rail (sold by the inch) ( <i>for 460/480 volt models Only</i> )
21	150300	2	#10 x 1/2" Hex Washer TEK Screw ( <i>for 460/480 volt models Only</i> )

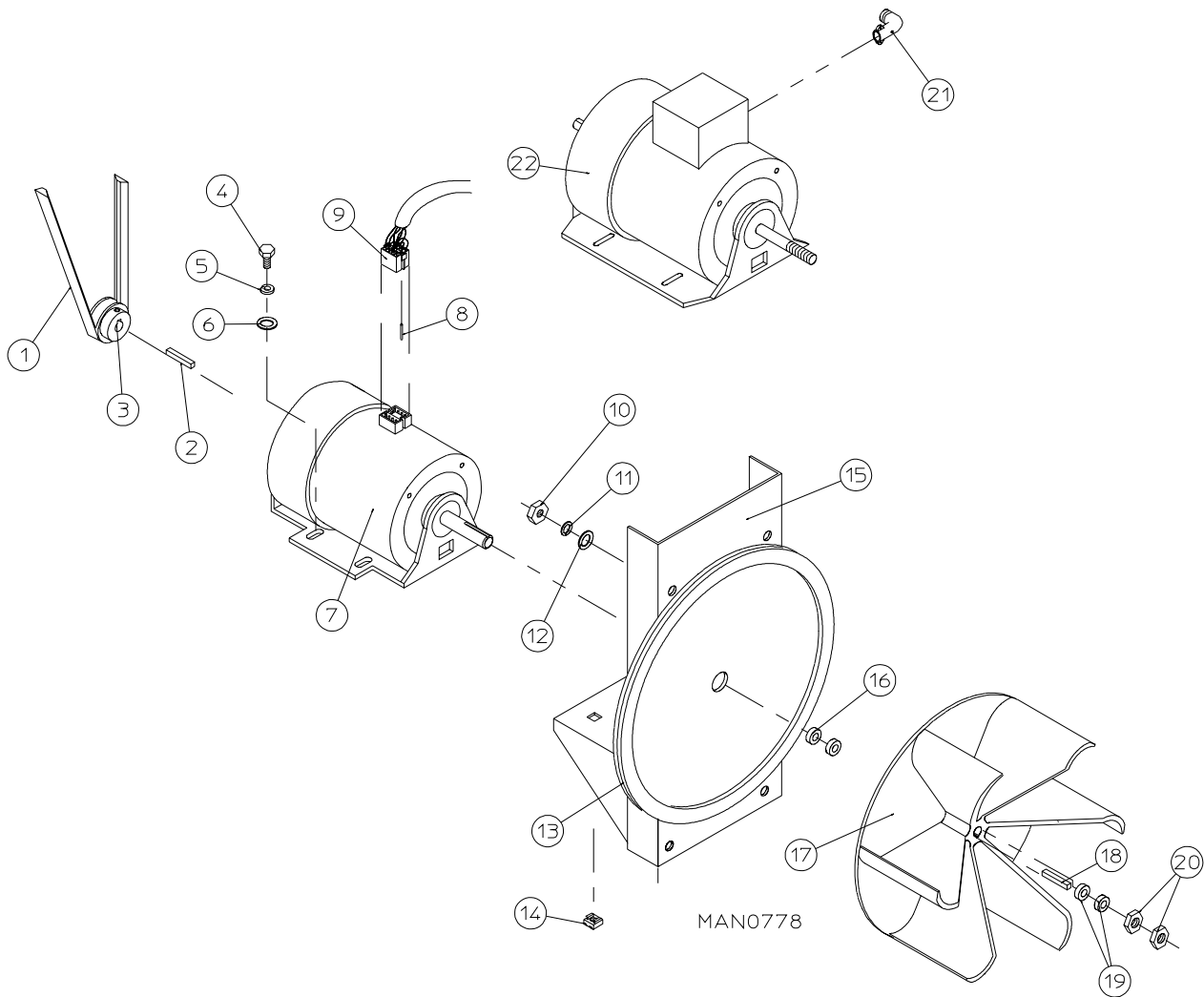

Illus. No.	Part No.	Qty.	Description
1	100117	1	4L 620 V-Belt (motor to idler)
2	100701	1	3/16" x 3/16" x 1" Key
3	101133	1	5/8" x 2-1/4" Motor Pulley (60 Hz Only)
4	150501	4	5/16-18 x 3/4" Hex Head Machine Bolt
5	153002	4	5/16" Lock Washer
6	153001	4	5/16" Flat Washer
7	100073*	1	1 HP 120/208/230v 1Ø 60 Hz T.E.F.C. Motor with Plug (56Z frame)
8	122701	8	Socket Terminal
	122801	1	Pin/Socket Extraction Tool
9	137030	1	8-Pin Housing Connector
	814764	1	120 Volt - 1Ø Motor Harness
10	152004	4	5/16-18 Hex Nut
11	153002	4	5/16" Lock Washer
12	153001	4	5/16" Flat Washer
13	117600	4	Noise Suppressor Tape (sold by the foot)
14	154000	4	5/16-18 Tinnerman Nut
15	800919	1	Non-Reversing Motor Mount ONLY (56Z frame)
	803992*	1	1 HP 120/230v 1Ø 60 Hz T.E.F.C. Motor Mount Assembly with Plug Complete (includes illus. nos. 2 through 7 and 13 through 20)
	803955*	1	1 HP 230/380/460v 3Ø 60 Hz Non-Reversing T.E.F.C. Motor Mount Assembly Complete (includes illus. nos. 2 through 6 and 13 through 22)
16	153051	1	3/4" S.A.E. Flat Washer
17	100603	1	16" Impellor with 3/4" Bore
18	100714	1	3/16" x 3/16" x 1-7/8" Key
19	153050	2	1/2" S.A.E. Flat Washer
20	152006	2	1/2-20 Left Hand Jam Nut
21	120200	1	3/8" x 90° Connector
	814772	1	3-Phase (3Ø) Motor Harness
22*	100075	1	1 HP 208/230/240/460v 3Ø 50/60 Hz T.E.F.C. Motor

\* Specify voltage when ordering.

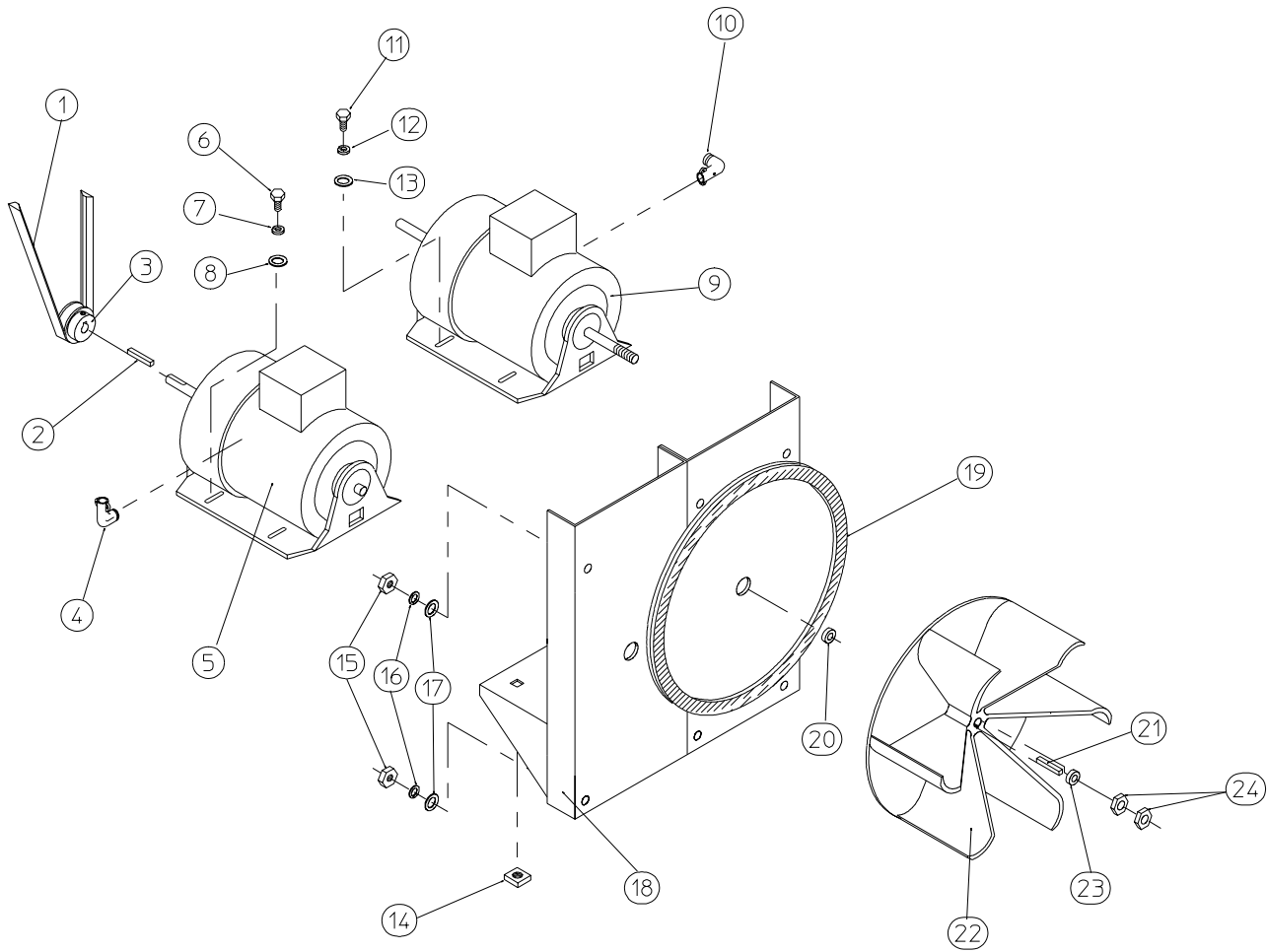

MAN0250

Illus. No.	Part No.	Qty.	Description
1	100112	1	4L-630 V-Belt (motor to idler)
2	100701	1	3/16" x 3/16" x 1" Key
3	101130	1	5/8" x 2-1/2" Motor Pulley (60 Hz ONLY)
4	120200	1	3/8" x 90° Connector
	814780	1	3-Phase (3Ø ) Drive Motor Harness
5*	181003	1	1/2 HP 208/230/380/460v 3Ø 50/60 Hz T.E.F.C. (56Z frame)
6	150501	4	5/16-18 x 3/4" Hex Head Machine Bolt
7	153002	4	5/16" Lock Washer
8	153001	4	5/16" Flat Washer
9*	100075	1	1 HP 220/230/380/460v 3Ø 50/60 Hz T.E.F.C. Motor with 3/4" Shaft (56Z frame)
10	120200	1	3/8" x 90° Connector
	814779	1	3-Phase (3Ø) Blower (Fan/Impellor) Motor Harness
11	150501	4	5/16-18 x 3/4" Hex Head Machine Bolt
12	153002	4	5/16" Lock Washer
13	153001	4	5/16" Flat Washer
14	154000	8	5/16" Tinnerman Nut
15	152004	7	5/16" Hex Nut
16	153002	4	5/16" Lock Washer
17	153001	4	5/16" Flat Washer
18	803566	1	Reversing Motor Mount ONLY (56Z frame)
	804029*	1	Reversing T.E.F.C. Motor Mount Assembly Complete (for 60 Hz Models ONLY) (includes illus. nos. 2 through 14 and 18 through 24)
	804030	1	(for 50 Hz Models ONLY) (includes illus. nos. 2 through 14 and 18 through 24)
19	117600	4	Noise Suppressor Tape (sold in feet)
20	153050	1	1/2" S.A.E. Flat Washer
21	100702	1	1/8" x 1/8" x 1-1/2" Key
22	100603	1	16" Impellor with 3/4" Bore
23	153050	**	1/2" S.A.E. Flat Washer
24	152006	2	1/2-20 Left Hand Jam Nut

\* Specify voltage when ordering.

\*\* As required.

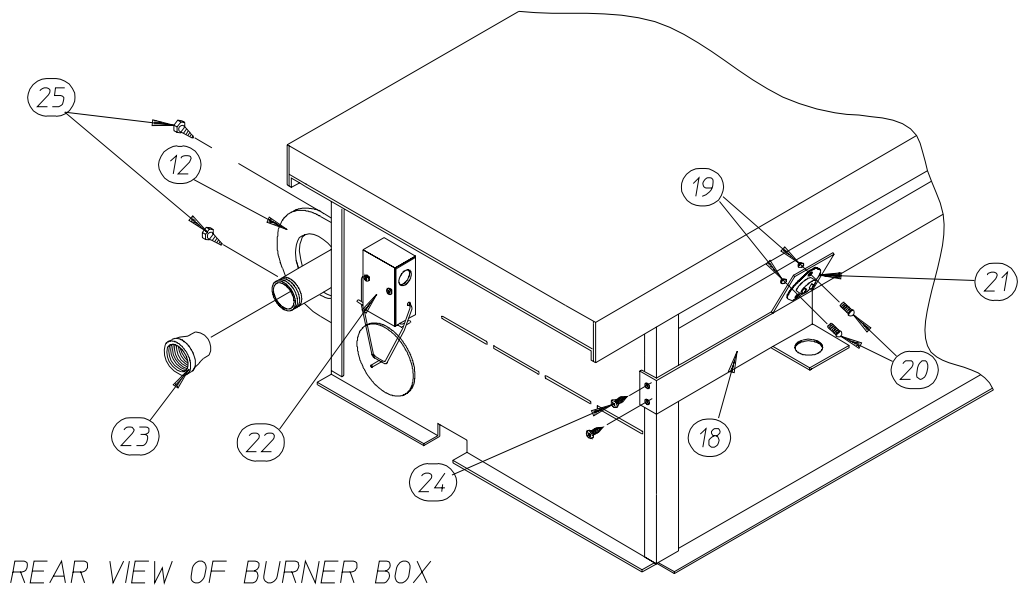
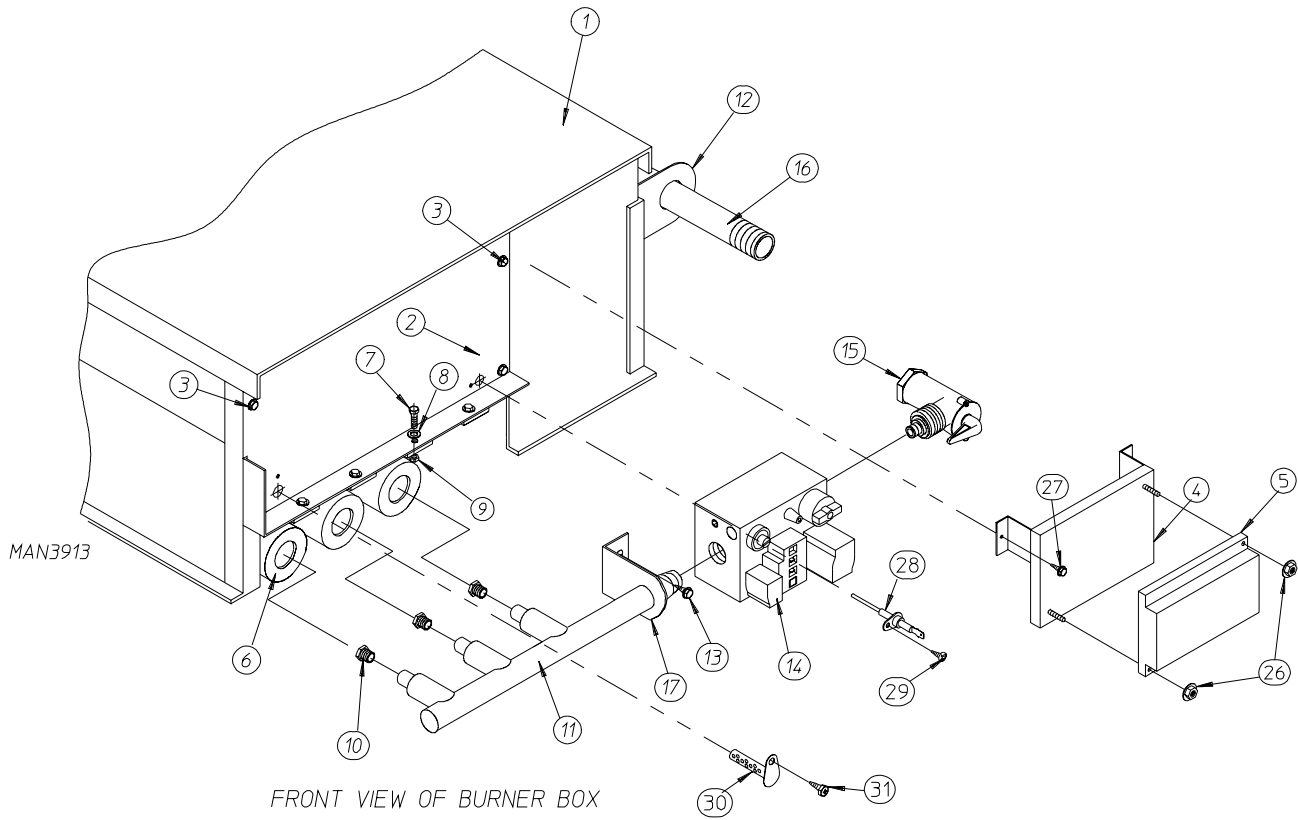



<u>Illus. No.</u>	<u>Part No.</u>	<u>Qty.</u>	<u>Description</u>
1	882022*	1	Natural Gas Burner Assembly Complete Less Orifices (includes illus. nos. 1 through 9 and 11 through 29) For models mfd. with Natural Gas ONLY
	882023*	1	L.P. (liquid propane) Gas Burner Assembly Complete Less Orifices (includes illus. nos. 1 through 9 and 11 through 29) For models mfd. with L.P. (liquid propane) Gas ONLY
	802237	1	Burner Box ONLY
	881655**	1	Burner L.P. Conversion Kit
2	353260	1	Burner Box Front ONLY
3	150413	5	#10-16 x 1/2" Hex Head TEK Crimptite Screw
4	810029	1	Hot Surface Ignition (HSI) Module Mounting Bracket
5	881797	1	HSI (Hot Surface Ignition) Module II
6	141105	3	Large Burner Tube
7	150103	3	#8-32 x 1/2" Phillips Round Head Machine Screw
8	153000	3	#8 Steel Burr
9	151001	3	#8-32 Pal Nut
10**	140853	3	#23 Burner Orifice (natural gas) ONLY
	140810	3	#42 Burner Orifice (liquid propane gas) ONLY
11	141232	1	3-Port Manifold
12	318700	2	Pipe Bracket
13	150300	2	#10 x 1/2" Hex Washer TEK Screw
14	128927	1	1/2" 24 VAC Redundant (natural gas) Gas Valve
	880960	1	1/2" 24 VAC L.P. (liquid propane) Gas Valve Assembly
	140411	1	24 VAC Gas Valve L.P. (liquid propane) Conversion Kit
15	881367	1	1/2" Union Shut Off with Tail Piece
16	142809	1	1/2" x 29-1/8" Nipple
17	323737	1	Pipe Bracket
18	319704	1	Hi-Limit Mounting Bracket
19	151000	2	#6-32 Pal Nut
20	150001	2	#6-32 x 1/2" Phillips Round Head Machine Screw
21	130401	1	330° F Hi-Limit ONLY
22	-----	1	Sail Switch (refer to <b>Sail Switch Assembly</b> on <b>page 34</b> )
23	143000	1	3/4" TO 1/2" Reducing Coupling
	142936	1	3/4" BSPT x 1/2" Reducing Coupling (CE dryers only)
24	150413	2	#10-16 x 1/2" Hex Head TEK Crimptite Screw
25	150413	2	#10-16 x 1/2" Hex Head TEK Crimptite Screw
26	151001	2	#8-32 Pal Nut
27	150413	3	#10-16 x 1/2" Hex Head TEK Crimptite Screw
28	128921	1	HSI Flame Sensor
29	150301	1	#8-18 x 7/16" Phillips Pan Head TEK Screw
30	881597	1	Hot Surface Ignitor (2-1/2" length) - 24 VAC
31	150413	1	#10-16 x 1/2" Hex Head TEK Crimptite Screw

\* Burner orifices are not included and must be ordered separately.

\*\* Consult factory for elevations over 2,000 feet.

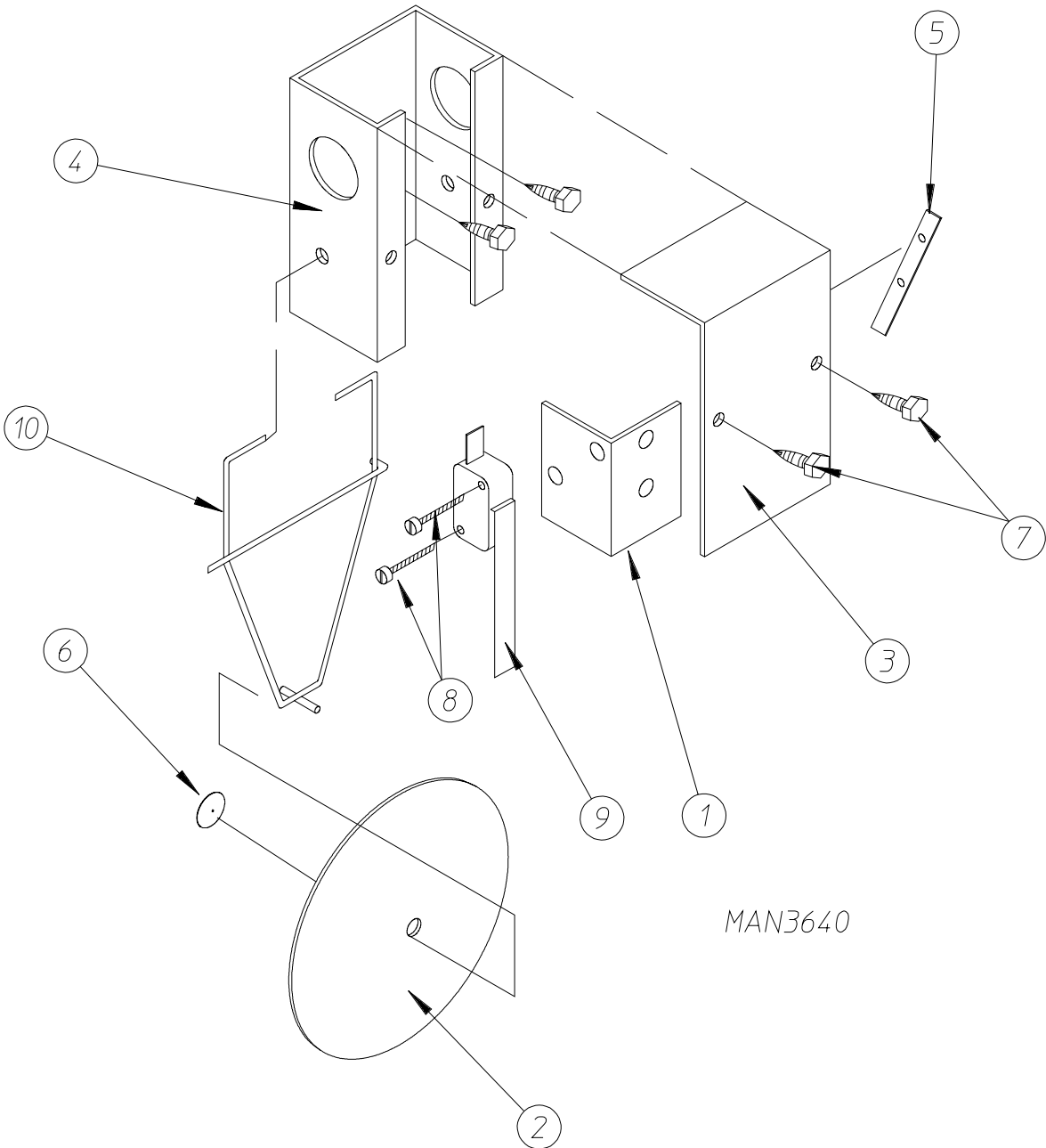

MAN3640

<u>Illus. No.</u>	<u>Part No.</u>	<u>Qty.</u>	<u>Description</u>
1	319203	1	Sail Switch Mounting Bracket
2	319202	1	Sail Switch Damper (flat)
3	319201	1	Sail Switch Box Cover
4	319200	1	Sail Switch Box
5	154004	1	Twin Speed Nut
6	154002	1	1/8" Push-on Fastener
7	150300	4	#10-16 x 1/2" Phillips Hex Head TEK Crimptite Screw
8	150303	2	#4 x 3/4" Pan Head "A" Machine Screw
9	122200	1	Sail Switch ONLY
	881706	1	Sail Switch Box Assembly Complete (includes illus. nos. 1 through 10)
10	105500	1	Sail Switch Actuator Rod

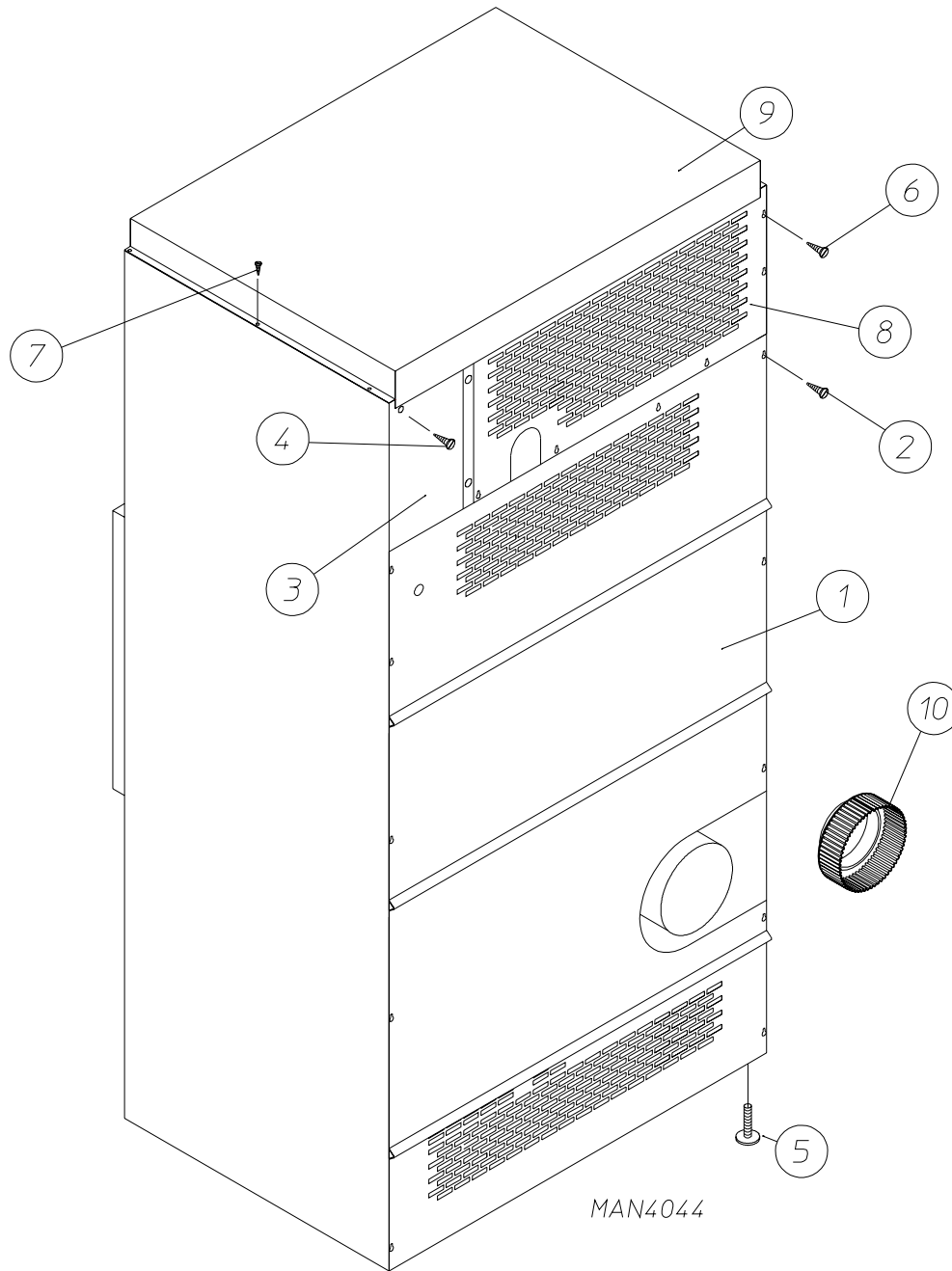

<u>Illus. No.</u>	<u>Part No.</u>	<u>Qty.</u>	<u>Description</u>
1	314501	1	Bottom Back Guard (for models manufactured as of July 13, 1998)
	314739	1	Bottom Back Guard (for models manufactured prior to July 13, 1998)
2	150301	12	#8-18 x 7/16" Phillips Pan Head TEK Screw
3	322809	1	Rear Electrical Box Cover
4	150301	4	#8-18 x 7/16" Phillips Pan Head TEK Screw
5	103500	4	Leveling Leg
6	150301	7	#8-18 x 7/16" Phillips Pan Head TEK Screw
7	150301	12	#8-18 x 7/16" Phillips Pan Head TEK Screw
8	314738	1	Top Back Guard
9	314757	1	Outer Top
10	882099	1	8" to 10" inverter (for models manufactured as of July 13, 1998)

<u>Part No.</u>	<u>Description</u>
112039	"Black/White/Green Ground" Label
112040	"Lint Compartment" Label
112041	"CAUTION - Exhausted" Label
112284	"Phase 6 OPL Program Location Summary" Label
114006	"WARNING - Fire Hazards" Label
120100	3/8" Straight (BX) Connector
120300	3/8" x 45° (BX) Connector
120400	3/8" Red Jacket (BX) Insulator
120500	3/8" Jiffy Clip (BX Retainer Clip)
120600	3/8" Greenfield (BX)
120800	1/4" In-Line Connector
120802	Red Butt Connector
120902	#74B Wire Nut
120903	Crimp-on Wire Nut
121014	1/4" Insulated (female) Terminal
121499	4" Harness Tie
121500	7" Harness Tie
121503	Harness Tie Mounting Clip
122804	Manometer (Hydro Gauge) for measuring Gas Pressure
404502	White-Brush-In-Cap Bottle Touch-Up Paint
404507	Cornflower Blue Brush-In-Cap Bottle Touch-Up Paint
880200	Electrical Terminal (assortment) Kit
880884	Tumbler (Basket) Bearing Puller



