



ML-82 Parts Manual

Phase 6 Microprocessor

American Dryer Corporation
88 Currant Road
Fall River, MA 02720-4781
Telephone: (508) 678-9000 / Fax: (508) 678-9447
E-mail: techsupport@amdry.com

Retain This Manual In A Safe Place For Future Reference

American Dryer Corporation products embody advanced concepts in engineering, design, and safety. If this product is properly maintained, it will provide many years of safe, efficient, and trouble-free operation.

ONLY qualified technicians should service this equipment.

OBSERVE ALL SAFETY PRECAUTIONS displayed on the equipment or specified in the installation manual included with the dryer.

The following “**FOR YOUR SAFETY**” caution **must be** posted near the dryer in a prominent location.

FOR YOUR SAFETY

Do not store or use gasoline or other flammable vapors or liquids in the vicinity of this or any other appliance.

POUR VOTRE SÉCURITÉ

Ne pas entreposer ni utiliser d'essence ni d'autres vapeurs ou liquides inflammables dans le voisinage de cet appareil ou de tout autre appareil.

We have tried to make this manual as complete as possible and hope you will find it useful. **ADC** reserves the right to make changes from time to time, without notice or obligation, in prices, specifications, colors, and material, and to change or discontinue models.

Important

For your convenience, log the following information:

DATE OF PURCHASE _____ **MODEL NO.** ML-82

RESELLER'S NAME _____

Serial Number(s) _____

Replacement parts can be obtained from your reseller or the **ADC** factory. When ordering replacement parts from the factory, you can FAX your order to **ADC** at (508) 678-9447 or telephone your order directly to the **ADC** Parts Department at (508) 678-9000. Please specify the dryer **model number** and **serial number** in addition to the **description** and **part number**, so that your order is processed accurately and promptly.

The illustrations on the following pages may not depict your particular dryer exactly. The illustrations are a composite of the various dryer models. Be sure to check the descriptions of the parts thoroughly before ordering.

“IMPORTANT NOTE TO PURCHASER”

Information must be obtained from your local gas supplier on the instructions to be followed if the user smells gas. These instructions must be posted in a prominent location near the dryer.

Table of Contents

Control Door Assembly	2
Phase 6 OPL Microprocessor Control Panel Assembly	3
Front Panel/Main Door Assemblies	4
Main Door Switch Assembly	5
Front Panel Assembly	6
Lint Drawer/Lint Drawer Switch Assembly	7
Basket (Tumbler)/Support Assemblies	8
Sensor Bracket Assembly	9
Tumbler Bearing Assembly	10, 11
Idler Bearing Assembly	12
Blower Motor Assembly	13
Totally Enclosed, Fan-Cooled (T.E.F.C.) Drive Motor/Fan Shaft Motor Mount Assemblies	14, 15
Direct Spark Ignition (DSI) Burner Assembly	16, 17
Hot Surface Ignition (HSI) Burner Assembly	18, 19
Sail Switch Assembly	20
Reversing Relay Panel Assembly	21
Outer Top/Back Guard Assemblies	22
Additional Parts Available	23

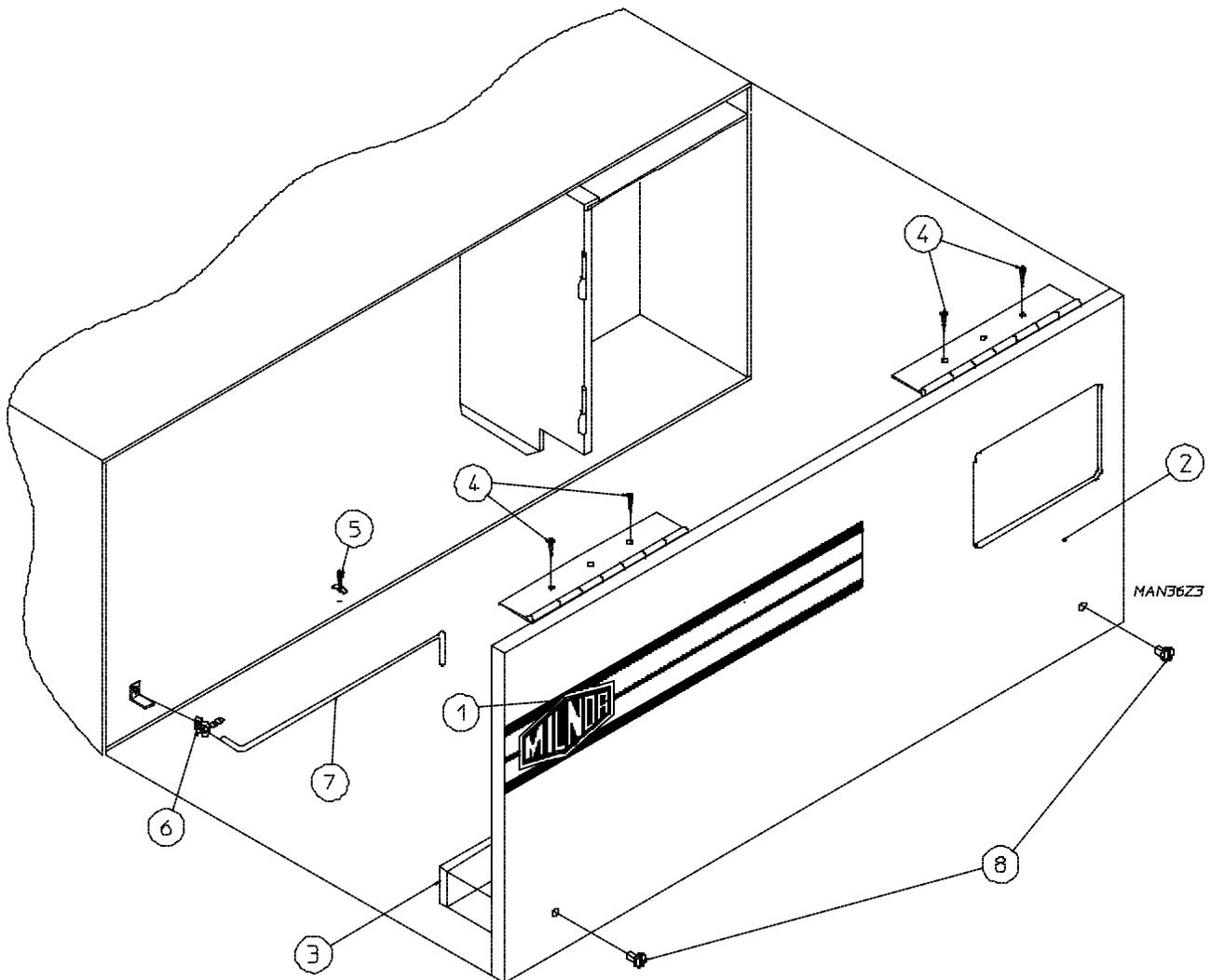

<u>Illus. No.</u>	<u>Part No.</u>	<u>Qty.</u>	<u>Description</u>
1	112366	1	Logo ONLY
2	881691	1	Control Door (includes illus. nos. 2, 3, and 8)
3	117604	4	Neoprene Sponge Tape (sold by the foot)
4	150309	4	#10-16 x 1/2" Hex Head TEK Crimptite Screw
5	102603	1	Control Door Rod Support Catch
6	102601	1	Control Door Retainer Clip
7	102502	1	Control Door Rod
8	882541	2	Spring Turn Latch (2-piece)

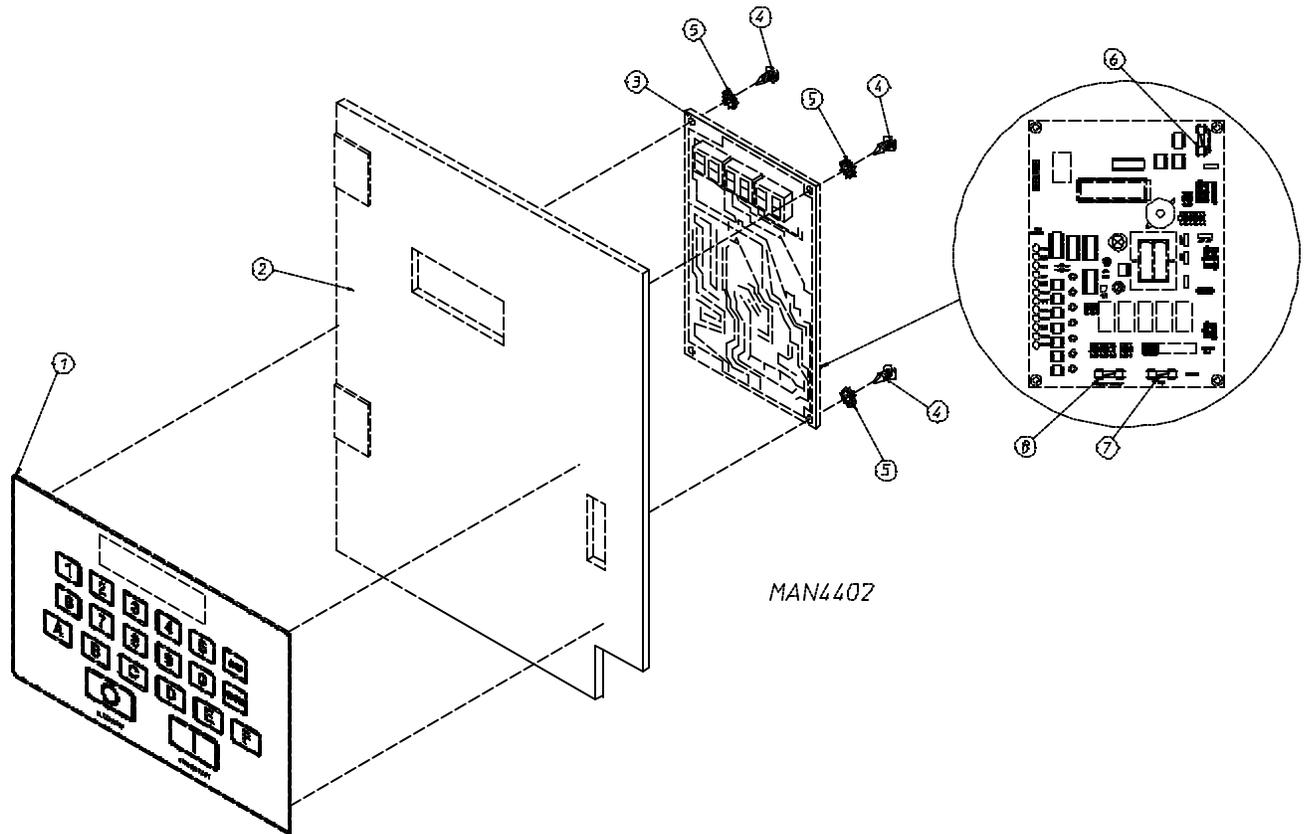

<u>Illus. No.</u>	<u>Part No.</u>	<u>Qty.</u>	<u>Description</u>
1	112537	1	Phase 6 OPL Keyboard
	112276	1	OPL Stick-On Labels (English Only) ... Not Illustrated
	112275	1	OPL Stick-On Labels (Spanish, Italian, and Hebrew) ... Not Illustrated
	112277	1	OPL Stick-On Labels (English, Spanish, and Hebrew) ... Not Illustrated
	112278	1	OPL Stick-On Labels (Italian, Dutch, French, German, and Chinese) ... Not Illustrated
2	881745	1	Phase 6 Microprocessor Controller (computer) Panel ONLY
	881746	1	Phase 6 OPL Reversing Microprocessor Controller (computer) Control Panel Assembly Complete (includes illus. nos. 1 through 8)
3	137122	1	Phase 6 OPL Reversing Microprocessor Controller (computer) ONLY
4	150005	2	#6-32 x 3/4" Phillips Round Head Machine Screw
5	153010	2	#6 Star Washer
6	136048	1	1/8-Amp (slo blo) Fuse ONLY
7	136017	1	3.15-Amp (fast acting) Fuse ONLY
8	136019	1	1-Amp (fast acting) Fuse ONLY

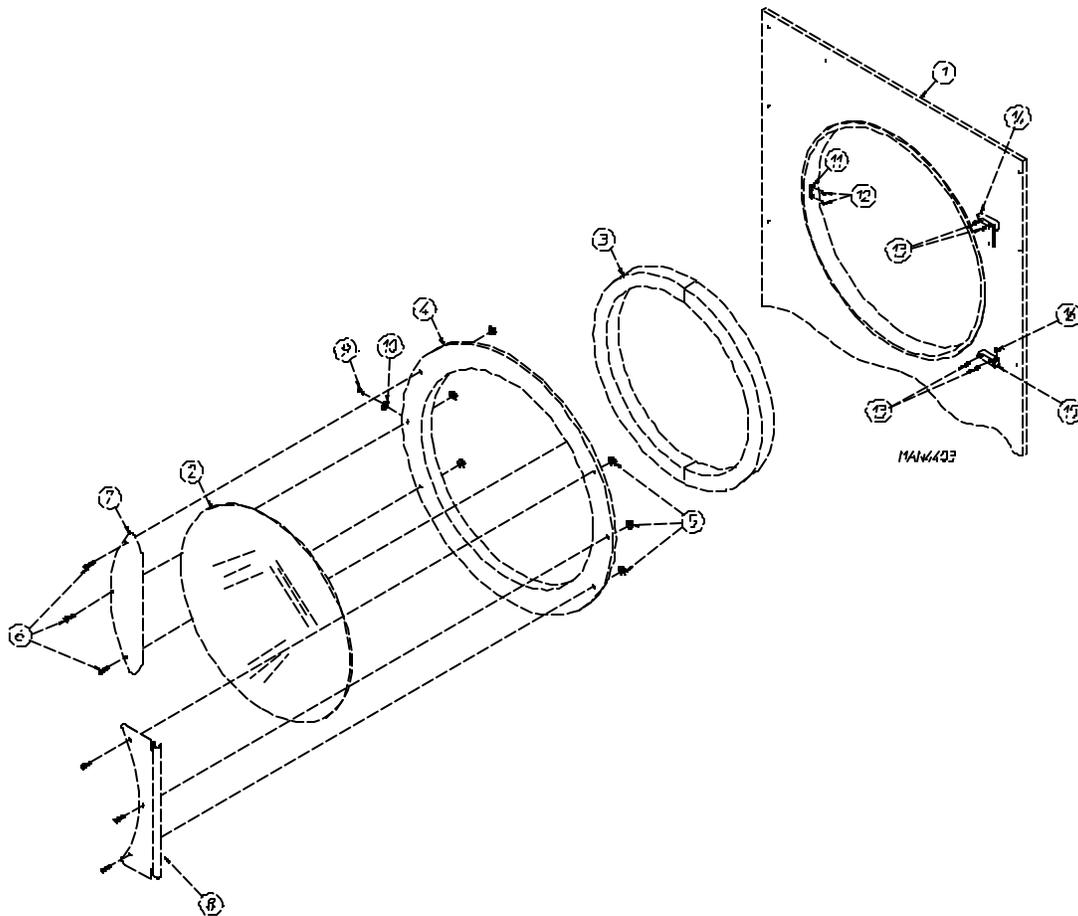

<u>Illus. No.</u>	<u>Part No.</u>	<u>Qty.</u>	<u>Description</u>
1	-----	1	Front Panel (refer to Front Panel Assembly on page 6)
2	102214	1	30" Door Glass ONLY
	170730	1	Door/Glass Adhesive (10.3 oz. cartridge)
3	102357	1	Main Door Gasket ONLY (7/8" x 7/8" x 104")
4	835003	1	Main Door Assembly Complete (includes illus. nos. 2 through 10)
	835002	1	Main Door Ring
5	881806	6	Free Spin Wash Nut
6	881740	6	1/4-20 x 5/8" Carriage Bolt
7	881688	1	CRS Main Door Handle
8	881685	1	Main Door Hinge
9	150120	1	Main Door Latch Screw (#10-32 x 7/16" dome hex head screw)
10	152008	1	#10-32 Hex Nut
11	170330	1	Friction Door Catch
12	154215	2	5/32" Pop Rivet
13	150443	4	1/4-20 x 3/4" Stainless Steel Cap Screw
14	881440	1	Top Hinge Block (white) (includes illus. nos. 13 and 14)
15	881441	1	Bottom Hinge Block (white) (includes illus. nos. 13, 15, and 16)
16	153031	1	Nylon Washer

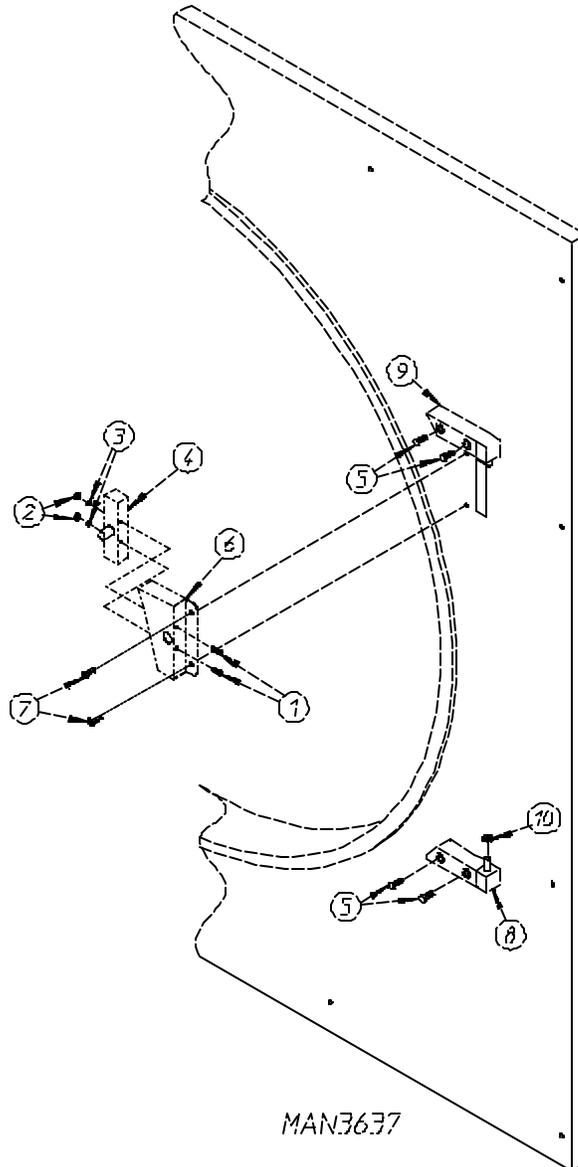

<u>Illus. No.</u>	<u>Part No.</u>	<u>Qty.</u>	<u>Description</u>
1	150006	2	#6-32 x 7/8" Phillips Pan Head Machine Screw
2	152013	2	#6-32 Hex Nut
3	153010	2	#6 Star Washer
4	137005	1	Single Pole Door Switch
5	150443	4	1/4-20 x 3/4" Stainless Steel Cap Screw
6	881687	1	Main Door Switch Housing ONLY
	881702	1	Main Door Switch with Housing Assembly (includes illus. nos. 1 through 4 and 6)
7	150301	2	#8-18 x 7/16" Phillips Pan Head TEK Screw
8	881441	1	Bottom Hinge Block (white) (includes illus. nos. 5, 8, and 10)
9	881440	1	Top Hinge Block (white) (includes illus. nos. 5 and 9)
10	153031	1	Nylon Washer

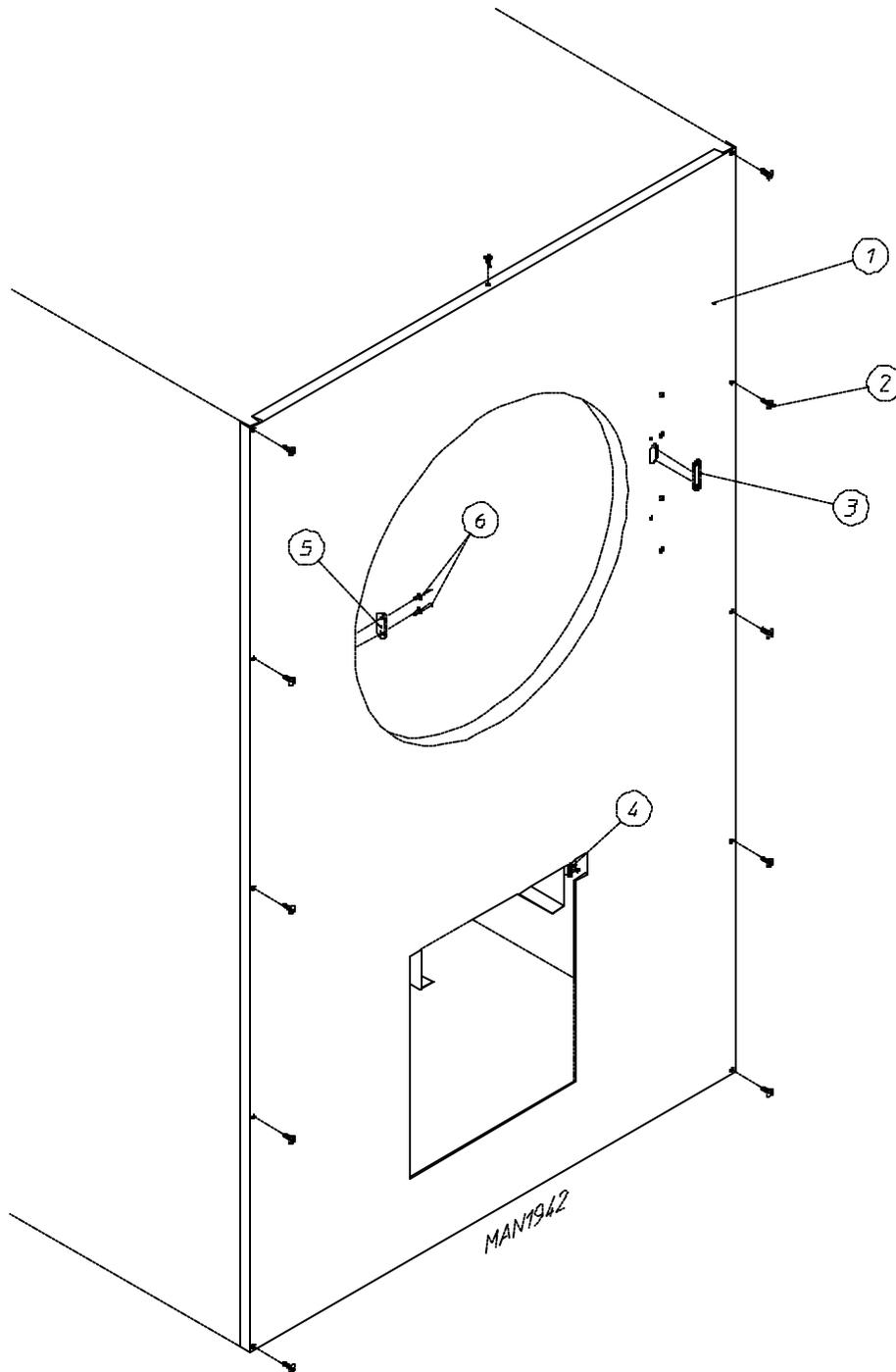

<u>Illus. No.</u>	<u>Part No.</u>	<u>Qty.</u>	<u>Description</u>
1	851054	1	Front Panel Assembly (includes illus. nos. 1, 3, 5, and 6)
2	150309	9	#10-16 x 1/2" Hex Head TEK Crimptite Screw
3	121405	1	Rubber Grommet
4	-----	1	Lint Drawer Switch (refer to Lint Drawer/Lint Drawer Switch Assembly on page 7)
5	170330	1	Friction Door Latch
6	154215	2	5/32" Pop Rivet

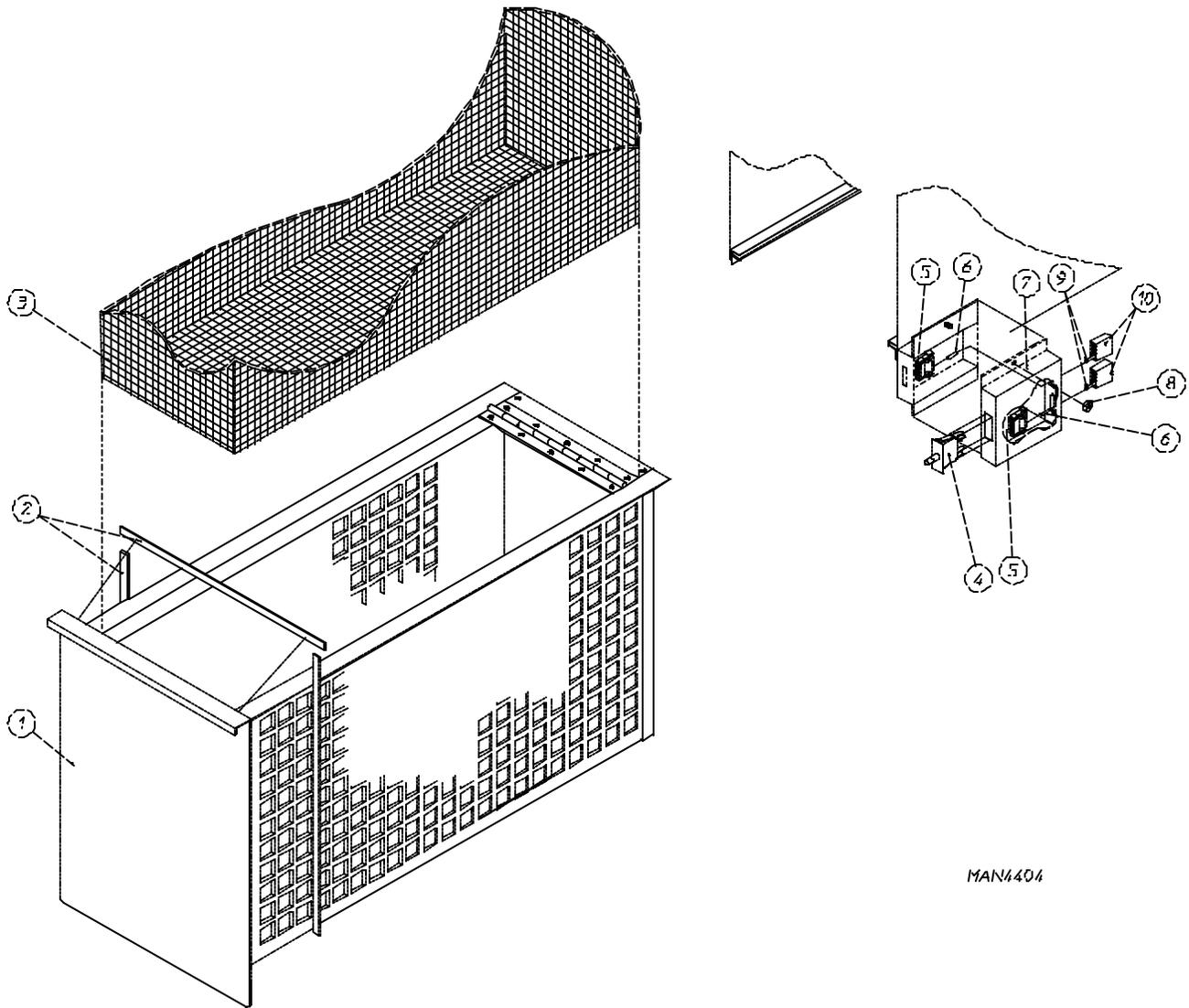

<u>Illus. No.</u>	<u>Part No.</u>	<u>Qty.</u>	<u>Description</u>
1	881463	1	Lint Drawer Assembly (includes illus. nos. 1 and 2 Only)
2	117605	5	Neoprene Sponge Gasket (sold by the foot)
3	802205	1	Lint Screen Assembly
4	122116	1	Lint Drawer Switch
	835078	1	Lint Drawer Switch Harness ... Not Illustrated
5	122605	2	4-Pin Socket Connector
6	122701	4	Socket Terminal ONLY
	122801	1	Socket Terminal Extraction Tool
7	835073	1	Lint Drawer Switch Box Assembly (includes illus. nos. 4 through 8)
	304136	1	Lint Switch Cover ONLY
8	152000	1	#6-32 Hex Nut
9	122700	4	Pin Terminal ONLY
10	122604	2	4-Pin Connector ONLY

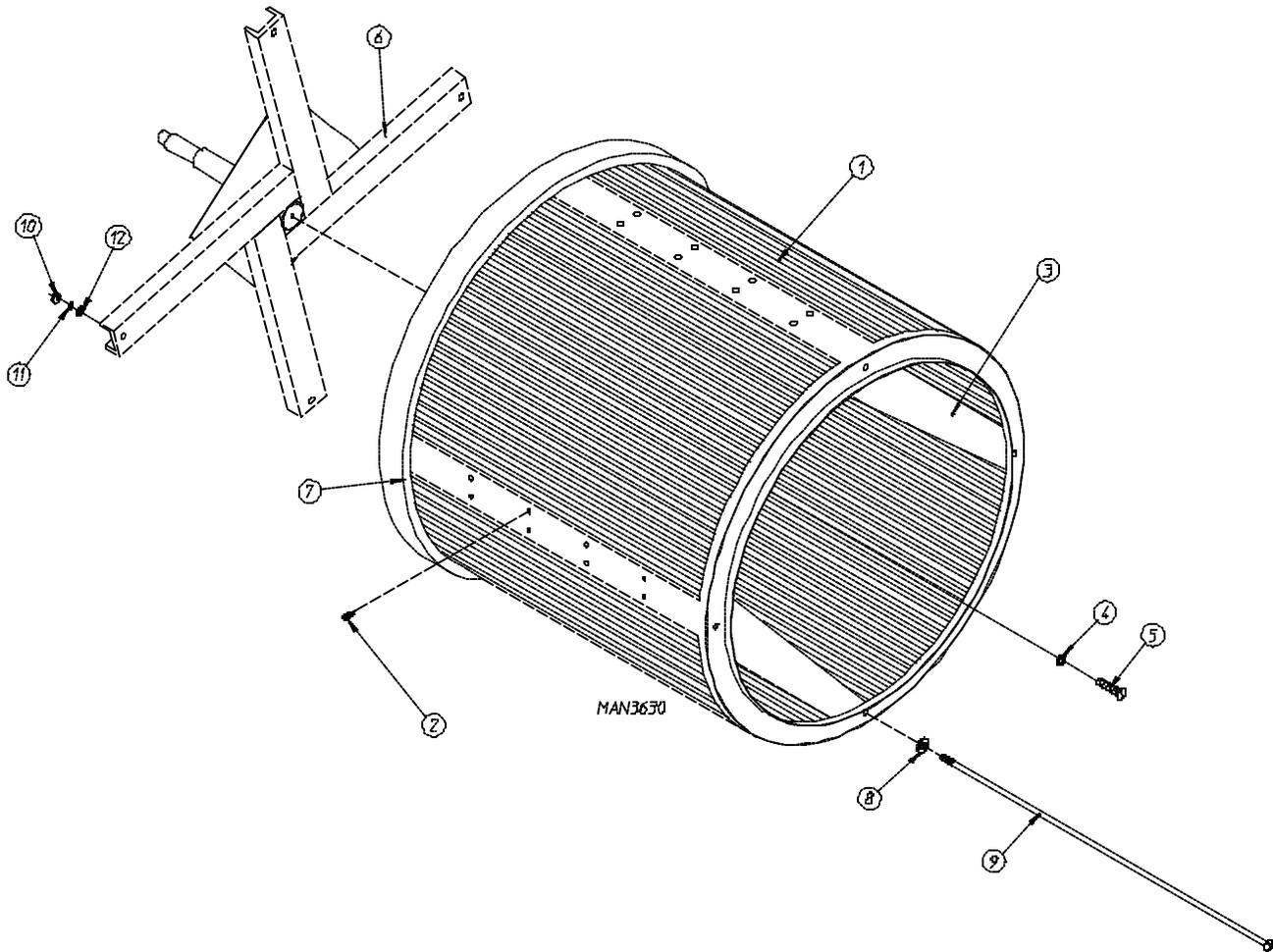

<u>Illus. No.</u>	<u>Part No.</u>	<u>Qty.</u>	<u>Description</u>
1	881780	1	Basket (tumbler) ONLY
	881782	1	1-3/4" Reversing Basket (tumbler)/Support Assembly Complete (includes illus. nos 1 through 12)
2	150413	40	#10-16 x 1/2" TORX Head Crimptite Screw
	150429	1	TORX Hand Driver (for removal of TORX head screw)
3	390074	4	Basket (tumbler) Rib ONLY
4	153002	1	5/16" Lock Washer
5	150500	1	5/16-18 x 3/4" Socket Button Head Screw
6	881779	1	Basket (tumbler) Support ONLY
7	116000	1	Felt Collar ONLY
	401010	1	#847 Adhesive For Felt Collar (5 oz. tube)
8	153004	4	3/8" Flat Washer
9	100905	4	3/8-16 x 37" Tie Rod
10	152005	4	3/8-16 Hex Nut
11	153005	4	3/8" Lock Washer
12	153004	4	3/8" Flat Washer

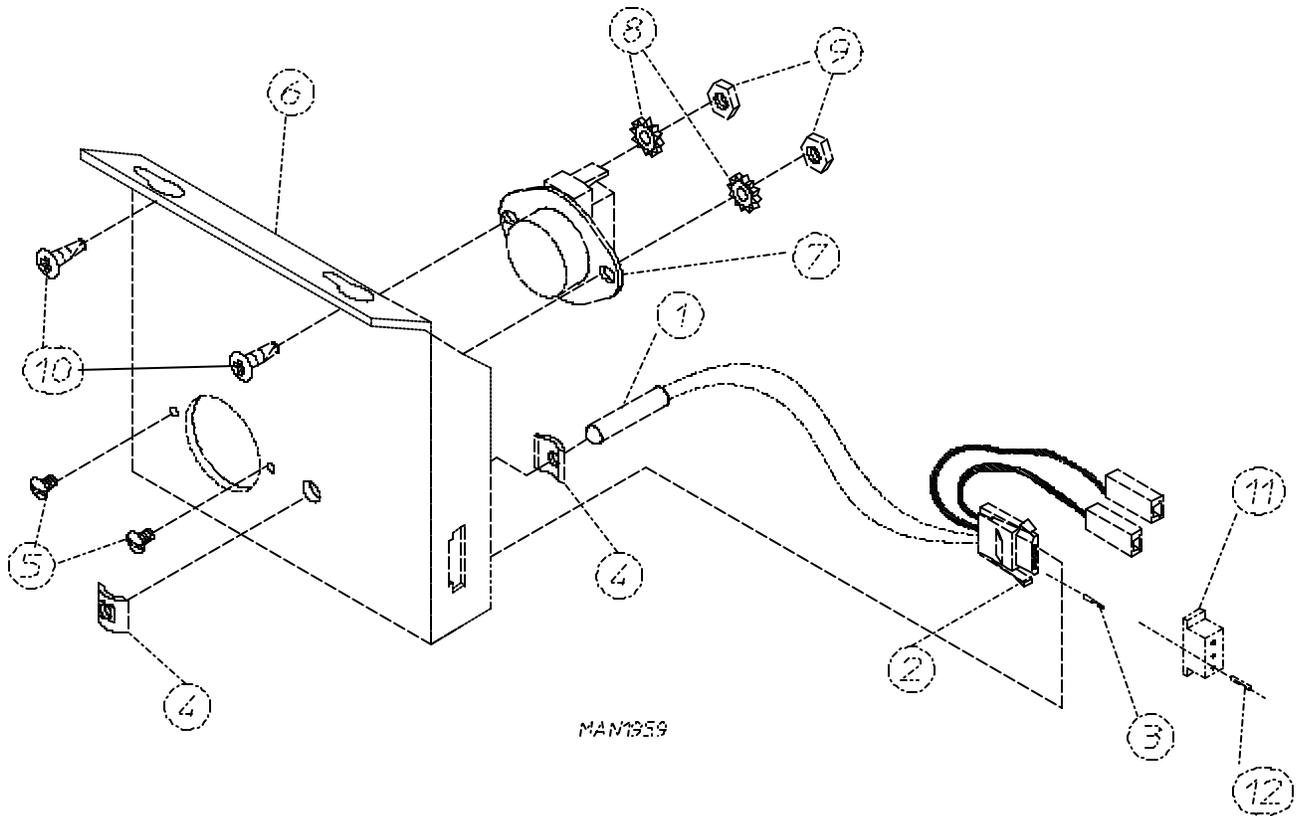

<u>Illus. No.</u>	<u>Part No.</u>	<u>Qty.</u>	<u>Description</u>
1	880251	1	1/4" Temperature Sensor Probe Assembly (includes illus. nos. 1 through 4)
2	122605	1	4-Pin Socket Connector ONLY
3	122701	4	Socket Terminal ONLY
4	154007	2	1/4" Tinnerman Push On Fastener
5	150000	2	#6-32 x 1/4" Round Head Machine Screw
6	802174	1	Sensor Bracket Assembly Complete (includes illus. nos. 1 through 9)
	323626	1	Temperature Sensor Bracket ONLY
7	130301	1	225° Large Manual Reset Thermostat
8	153010	2	#6 Star Washer
9	152000	2	#6-32 Hex Nut
10	150301	2	#8-18 x 7/16" Phillips Pan Head TEK Screw
11	122604	1	4-Pin Connector ONLY
12	122700	4	Pin Terminal ONLY
---	122801	1	Pin/Extraction Tool

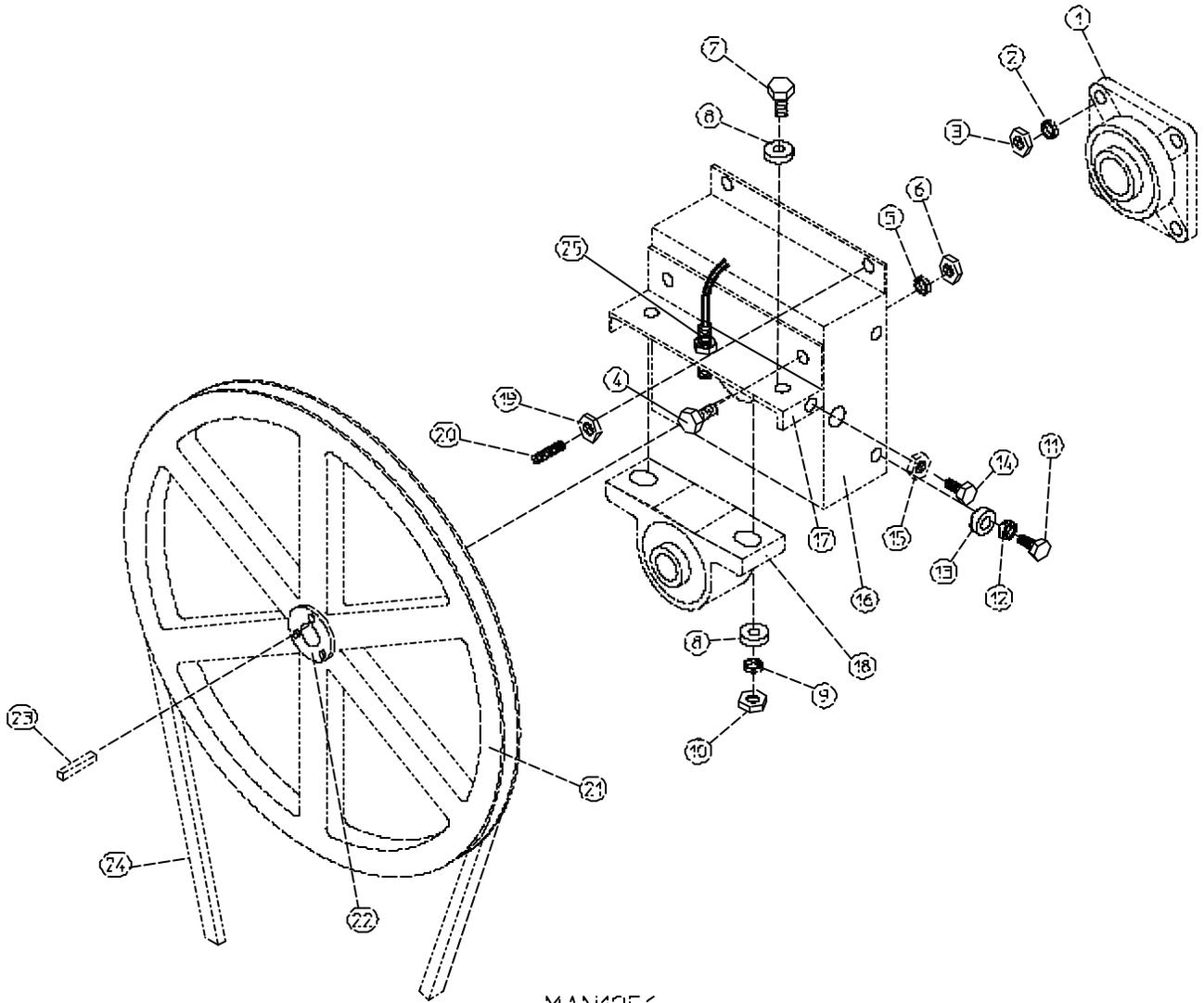

MAN1956

<u>Illus. No.</u>	<u>Part No.</u>	<u>Qty.</u>	<u>Description</u>
1	880220	1	1-3/4" Flange Bearing
2	153025	4	9/16" Lock Washer
3	152050	4	9/16-12 Hex Nut
4	150508	2	3/8-16 x 3/4" Hex Head Machine Bolt
5	153005	4	3/8" Lock Washer
6	152005	2	3/8-16 Hex Nut
7	150600	2	3/8-16 x 1-1/2" Hex Head Machine Bolt
8*	153004	6	3/8" Flat Washer
9	153005	2	3/8" Lock Washer
10	152005	4	3/8-16 Hex Nut
11	150501	4	5/16-18 x 3/4" Hex Head Machine Bolt
12	153002	4	5/16" Lock Washer
13	153001	4	5/16" Flat Washer
14	150621	2	5/16-18 x 1-1/2" Hex Head Machine Bolt
15	152004	2	5/16-18 Hex Nut
16	801107	1	1-3/8" Bearing Box Assembly Complete with Rotational Sensor Assembly (includes illus. nos. 4 through 20 and 25)
	801103	1	1-3/8" Bearing Box and Support ONLY (includes illus. nos. 4 through 6, 16, and 17)
	801105	1	1-3/8" Bearing Box ONLY
17	801104	1	Pillow Block Bearing Support ONLY
18	880779	1	1-3/8" Pillow Block Bearing Assembly with Magnet
19	152004	4	5/16-18 Hex Nut
20	150610	2	5/16-18 x 1-1/2" Allen Set Screw
21	101118	1	18-3/4" Pulley
22	101119	1	1-3/8" Taper Lock Hub (key <i>is not included</i>)
23	100735	1	Shaft Key (for taper lock hub)
24	100106	1	5L-690 V-Belt (to idler assembly)
25	824807	1	Rotational Sensor Assembly

* Some models require a quantity of 4.

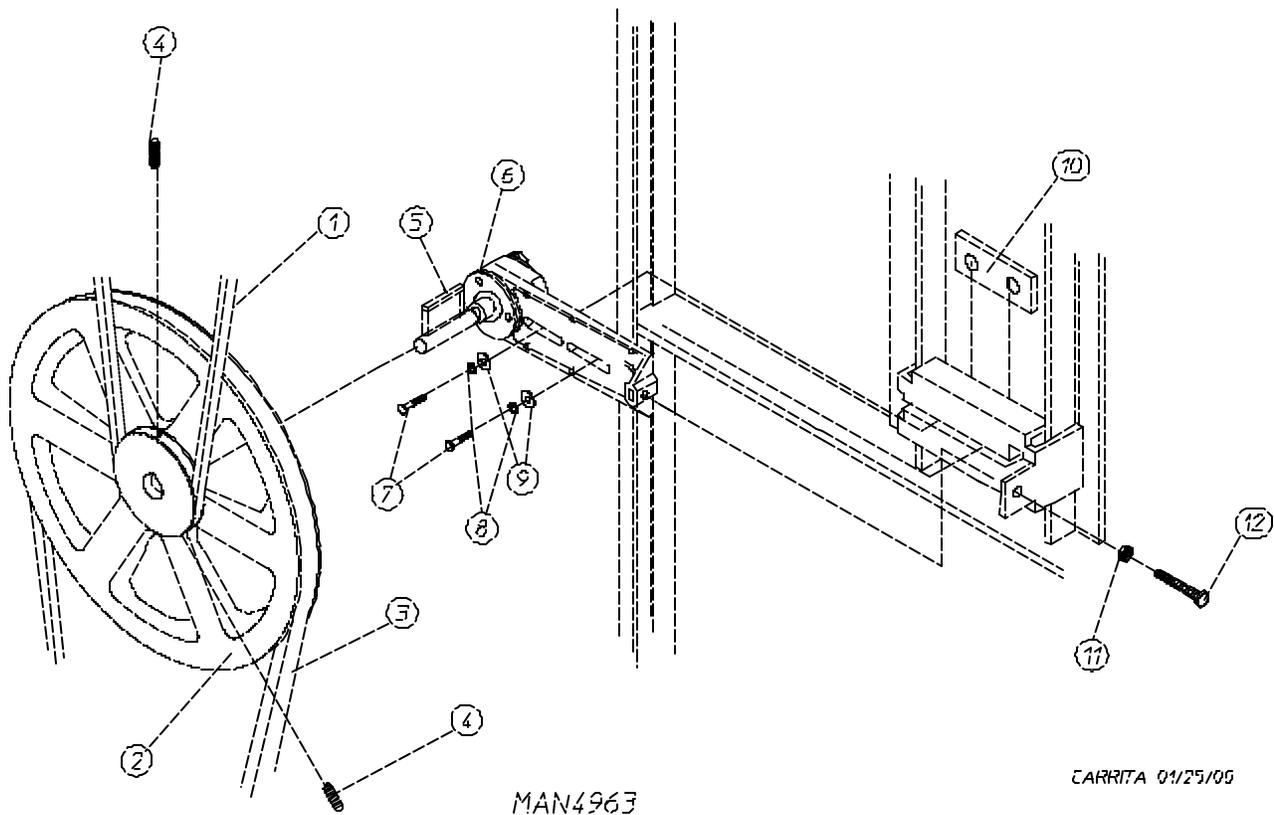

<u>Illus. No.</u>	<u>Part No.</u>	<u>Qty.</u>	<u>Description</u>
1	100106	1	5L-690 V-Belt (basket [tumbler] to idler)
2	101140	1	14" x 3" Compound Pulley
3	100158	1	4L-550 V-Belt (idler to motor)
4	154301	2	5/16-18 x 1" Allen Set Screw
5	100705	1	3/16" x 3/16" x 1-3/8" Key
6	801007	1	Idler Bearing Assembly Complete (includes illus. nos. 5 through 12)
7	150617	2	3/8-16 x 1" Hex Head Machine Bolt
8	153005	2	3/8" Lock Washer
9	153004	2	3/8" Flat Washer
10	801009	1	Idler Square Washer
11	152004	1	5/16-18 Hex Nut
12	150509	1	5/16-18 x 3" Hex Head Machine Bolt

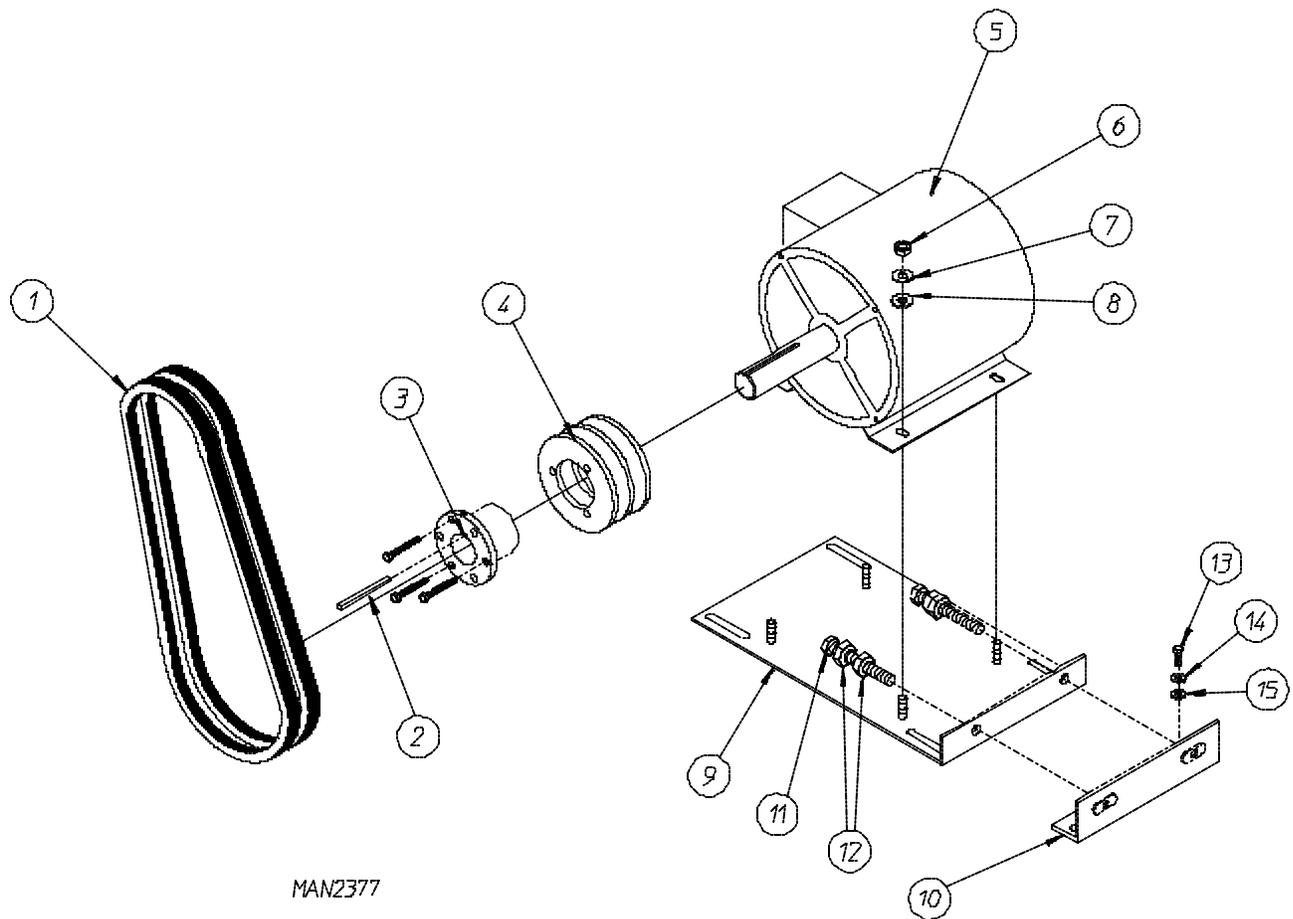

<u>Illus. No.</u>	<u>Part No.</u>	<u>Qty.</u>	<u>Description</u>
1*	100169	1	5L-350 V-Belt (fan shaft to motor)
2	100704	1	1/4" x 1/4" x 1-3/4" Key
3	101138	1	SDS x 1-1/8" Bushing
4	101202	1	2B x 5.2 Pulley
5**	100043	1	3 HP Motor
6	152004	4	3/8-16 Hex Nut
7	153002	4	3/8" Lock Washer
8	153001	4	3/8" Flat Washer
9	802253	1	Adjustment Plate
10	802232	1	Adjustment Angle
11	152034	2	3/8-16 x 3-1/2" Bolt
12	152005	4	3/8-16 Hex Nut
13	150501	4	5/16-18 x 3/4" Bolt
14	153005	4	3/8" Lock Washer
15	153004	4	3/8" Flat Washer

* Replace in matched sets (both belts).

** Check part number on motor data label to verify correct motor.

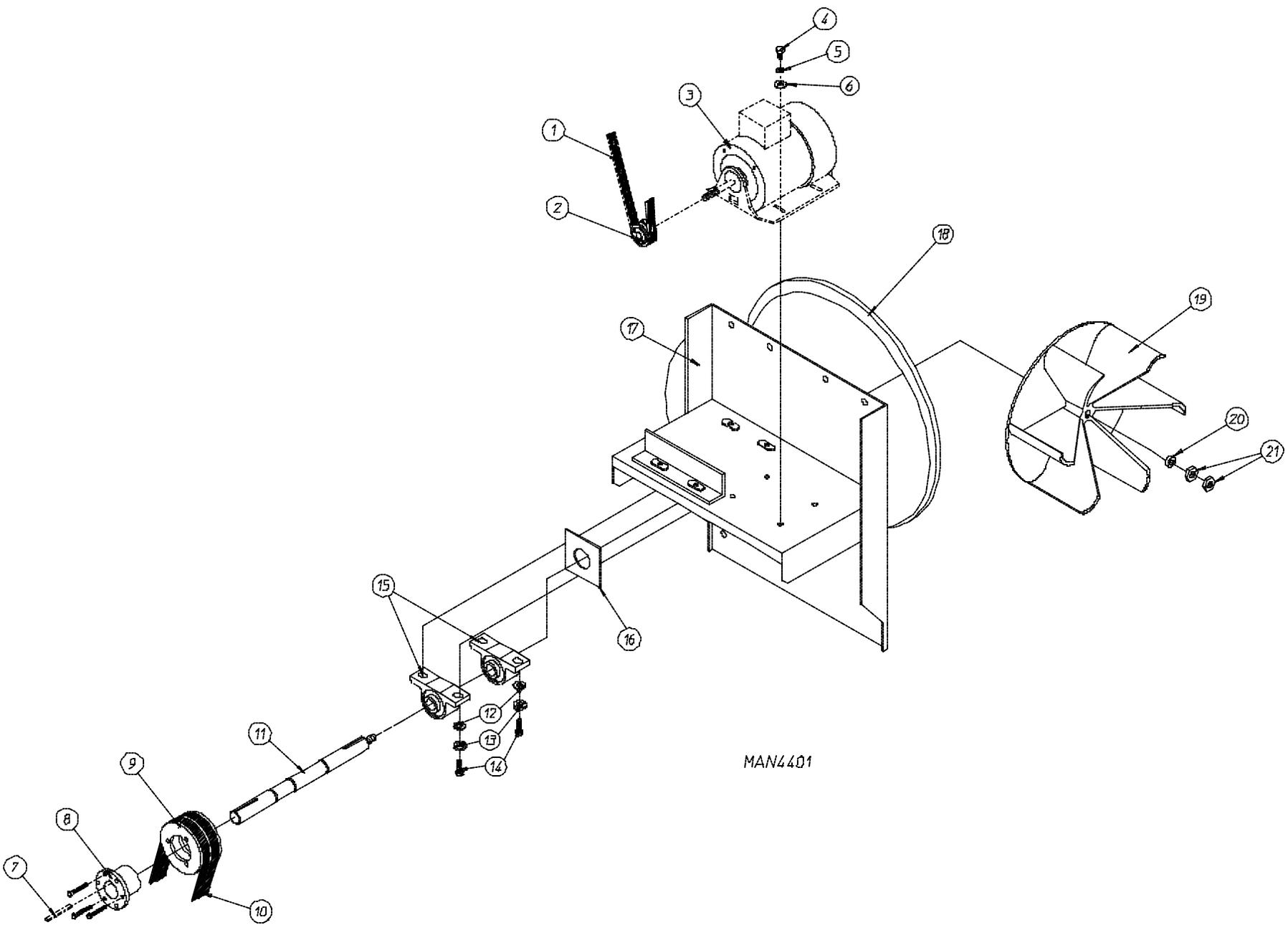

<u>Illus. No.</u>	<u>Part No.</u>	<u>Qty.</u>	<u>Description</u>
1	100158	1	4L-550 V-Belt (motor to idler)
2	101130	1	5/8" x 2-1/2" Motor Pulley
3*	181003	1	1/2 HP 3 ϕ Totally Enclosed, Fan-Cooled (T.E.F.C.) Motor
4	150501	4	5/16-18 x 3/4" Machine Bolt
5	153002	4	5/16" Lock Washer
6	153001	4	5/16" Flat Washer
7	100706	1	5/16" x 5/16" x 1-3/8" Key
8	101194	1	SDS x 1-3/8" Bushing
9	101147	1	2B x 4.8 Pulley
10**	100169	1	5L-350 V-Belt (fan shaft to motor)
11	317400	1	Impellor/Fan Shaft
12	153004	4	3/8" Flat Washer
13	153005	4	3/8" Lock Washer
14	150600	4	3/8-16 x 1-1/2" Machine Bolt
15	880879	2	1-3/8" Pillow Block Bearing with Set Screw and Grease Fitting
16	116014	1	3" x 3" Fan Shaft Gasket
17	802231	1	Fan Shaft Motor Mount ONLY
18	117604	5	Neoprene Sponge Tape (sold by the foot)
19	100603	1	16" Cast Impellor (fan)
20	153050	1	1/2" Flat Washer
21	152006	2	1/2-20 Left Hand Jam Nut

* Check part number on motor data label to verify correct motor.

** Replace in matched sets (both belts).

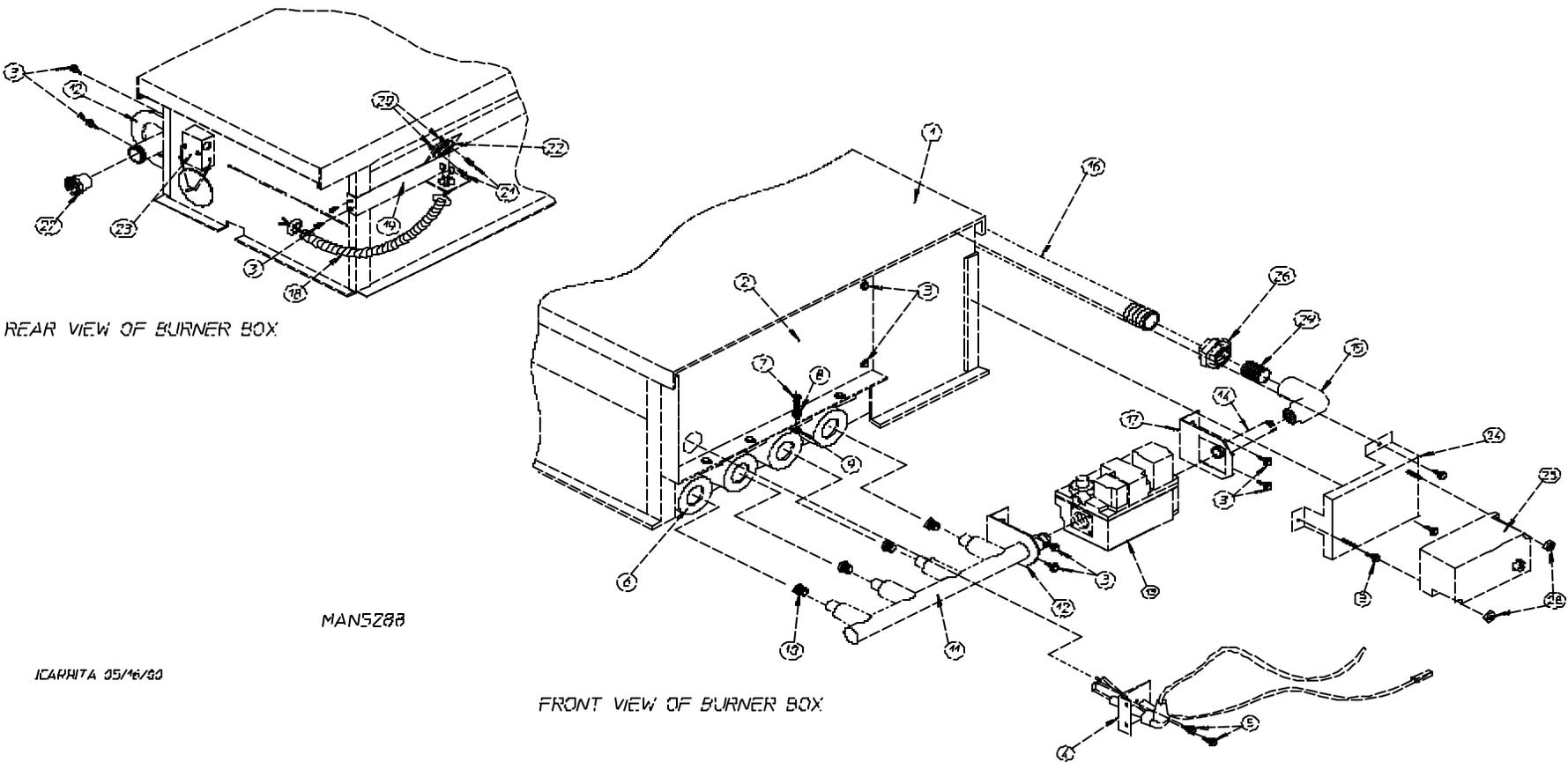

REAR VIEW OF BURNER BOX

FRONT VIEW OF BURNER BOX

MAN5288

ICARRITA 05/16/90

<u>Illus. No.</u>	<u>Part No.</u>	<u>Qty.</u>	<u>Description</u>
1*	803020	1	Natural Gas Burner Assembly Complete (includes illus. nos. 1 through 29)
	803021	1	Liquid Propane (L.P.) Burner Assembly Complete (includes illus. nos 1 through 29)
	802237	1	Burner Box ONLY
2	802240	1	Direct Spark Ignition (DSI) Burner Shield (4-tube burner)
3	150309	15	#10-16 x 1/2" Hex Head TEK Crimptite Screw
4	128915	1	Direct Spark Ignition (DSI) Ignitor/Flame-Probe Assembly
5	150300	2	#10 x 1/2" Hex Washer TEK Screw
6	141105	4	Large Burner Tube
7	150103	4	#8-32 x 1/2" Pan Head Machine Screw
8	153000	4	#8 Steel Burr
9	151001	4	#8-32 Pal Nut
10*	140856	4	#23 Burner Orifice (natural gas Only)
	140811	4	#41 Burner Orifice (liquid propane [L.P.] gas Only)
11	141210	1	3/4" Direct Spark Ignition (DSI) Manifold (4-port)
12	323737	2	Pipe Bracket (bent)
13	128928	1	1/2" 24 VAC Redundant (natural gas) Valve
	881052	1	1/2" 24 VAC Redundant (liquid propane [L.P.] gas) Valve
	882119	1	1/2" 24 VAC Redundant Liquid Propane (L.P.) Conversion Kit
14	142715	1	1/2" x 2" Nipple
15	142511	1	3/4" x 1/2" Reducing Elbow
16	142721	1	3/4" x 28" Pipe
17	323763	1	Gas Valve Bracket
18	824533	1	Hi-Limit Harness
19	319704	1	Hi-Limit Mounting Bracket
20	151000	2	#6-32 Pal Nut
21	151001	2	#6-32 x 1/2" Round Head Machine Screw
22	130201	1	330° Hi-Limit Manual Reset
23	-----	1	Sail Switch (refer to Sail Switch Assembly on page 20)
24	810030	1	Johnson Controls Direct Spark Ignition (DSI) Module Mounting Bracket
25	128935	1	Direct Spark Ignition (DSI) Module with Three Tries
26	142601	1	3/4" Union
27	142924	1	1" to 3/4" Reducing Coupling
28	152013	2	#6-32 Hex Nut 1/4" ATF Zinc Plated
29	142701	1	3/4" Close Nipple

* Consult factory for elevations over 2,000 feet.

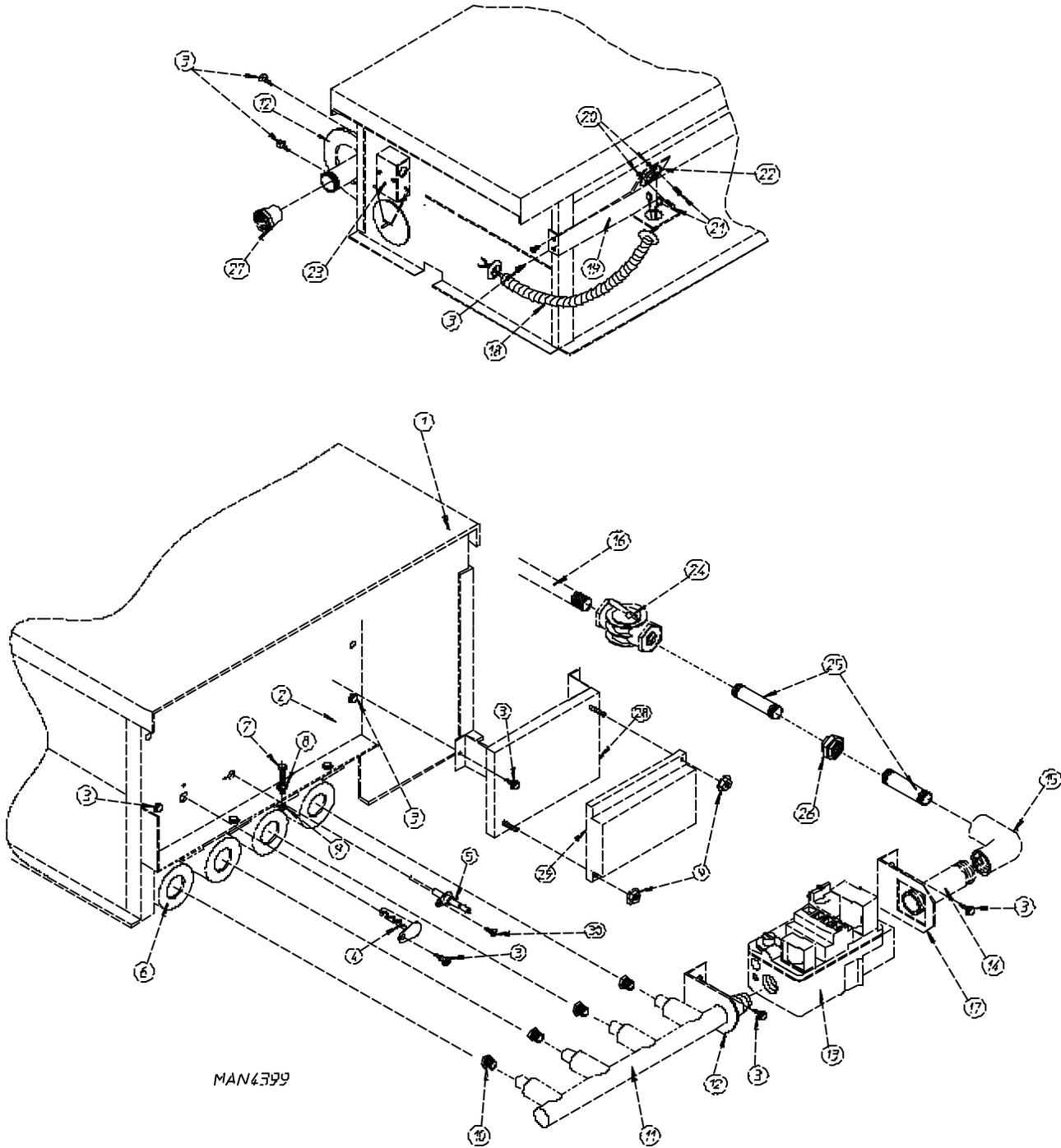

<u>Illus. No.</u>	<u>Part No.</u>	<u>Qty.</u>	<u>Description</u>
1	802237	1	Burner Box ONLY
	881258*	1	Natural Gas Burner Assembly Complete Less Orifices (includes illus. nos. 1 through 9 and 11 through 30)
	881257*	1	Liquid Propane (L.P.) Burner Assembly II Complete Less Orifice (includes illus. nos. 1 through 9 and 11 through 30)
2	318041	1	Burner Shield
3	150309	17	#10-16 x 1/2" Hex Head TEK Crimptite Screw

<u>Illus. No.</u>	<u>Part No.</u>	<u>Qty.</u>	<u>Description</u>
4	881597	1	Hot Surface Ignitor - 24 VAC
5	128921	1	Hot Surface Ignition (HSI) Flame-Probe
6	141105	4	Large Burner Tube
7	150103	4	#8-32 x 1/2" Phillips Pan Head Machine Screw
8	153000	4	#8 Steel Bar
9	151001	6	#8-32 Pal Nut
10**	140856	4	#23 Burner Orifice (natural gas) ONLY
	140811	4	#41 Burner Orifice (liquid propane [L.P.] ONLY)
11	141210	1	3/4" Manifold (4-port)
12	323769	2	Pipe Bracket (bent)
13	128928	1	1/2" 24 VAC Redundant (natural gas) Gas Valve
	881052	1	1/2" 24 VAC Redundant (liquid propane [L.P.]) Gas Valve
	882119**	1	Hot Surface Ignition (HSI) liquid propane (L.P.) Conversion Kit
14	142715	2	1/2" x 1/2" Nipple
15	142511	1	3/4" x 1/2" Reducing Elbow
16	142829	1	3/4" x 20" Pipe
17	323763	1	Gas Valve Bracket
18	842891	1	Sail Switch to Hi-Limit Harness
19	319704	1	Hi-Limit Mounting Bracket
20	151000	2	#6-32 Pal Nut
21	151001	2	#6-32 x 1/2" Round Head Machine Screw
22	130201	1	330° Manual Reset Hi-Limit Thermostat ONLY
23	-----	1	Sail Switch (refer to Sail Switch Assembly on page 20)
24	141300	1	3/4" Union Shutoff
25	142709	2	3/4" x 2" Nipple
26	142601	1	3/4" Union
27	142924	1	1" to 3/4" Reducing Coupling
28	810029	1	Hot Surface Ignition (HSI) Mounting Bracket Assembly
29	881797	1	Hot Surface Ignition (HSI) Module II
30	150301	1	#8-18 x 7/16" Phillips Pan Head TEK Screw

* Burner orifices *are not included* and **must be** ordered separately.

** Consult factory for elevations over 2,000 feet.

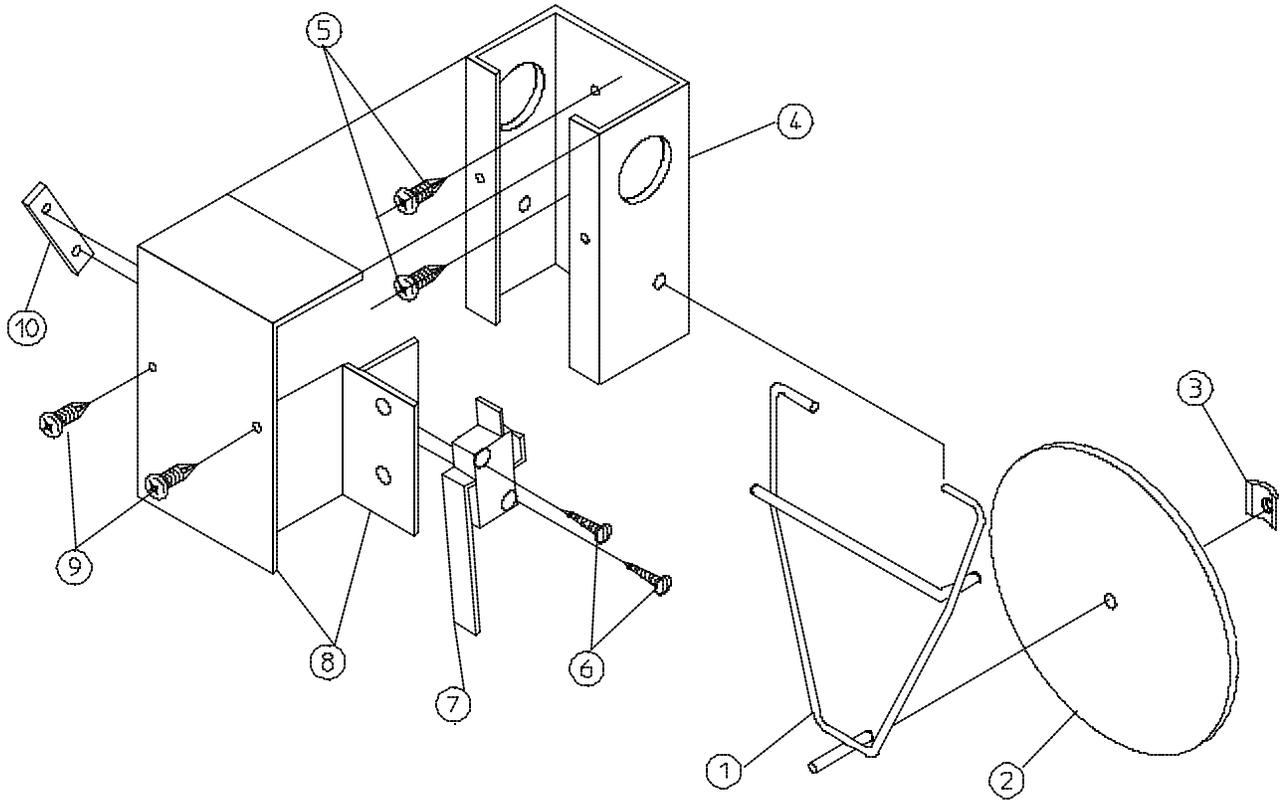

MAN0440

<u>Illus. No.</u>	<u>Part No.</u>	<u>Qty.</u>	<u>Description</u>
1	105500	1	Sail Switch Actuator Rod
2	319202	1	Sail Switch Damper (flat)
3	154002	1	1/8" Push On Fastener
4	802800	1	Sail Switch Box with Cover and Bracket ONLY (includes illus. nos. 4, 8, and 9)
	802801	1	Sail Switch Box Assembly Complete (includes illus. nos. 1 through 4 and 6 through 10)
5	150309	2	#10-16 x 1/2" Hex Head TEK Crimptite Screw
6	150303	2	#4 x 3/4" Pan Head "A" Machine Screw
7	122200	1	Sail Switch ONLY
8	802799	1	Sail Switch Box Cover and Bracket ONLY
9	150309	2	#10-16 x 1/2" Hex Head TEK Crimptite Screw
10	154004	1	Twin Speed Nut

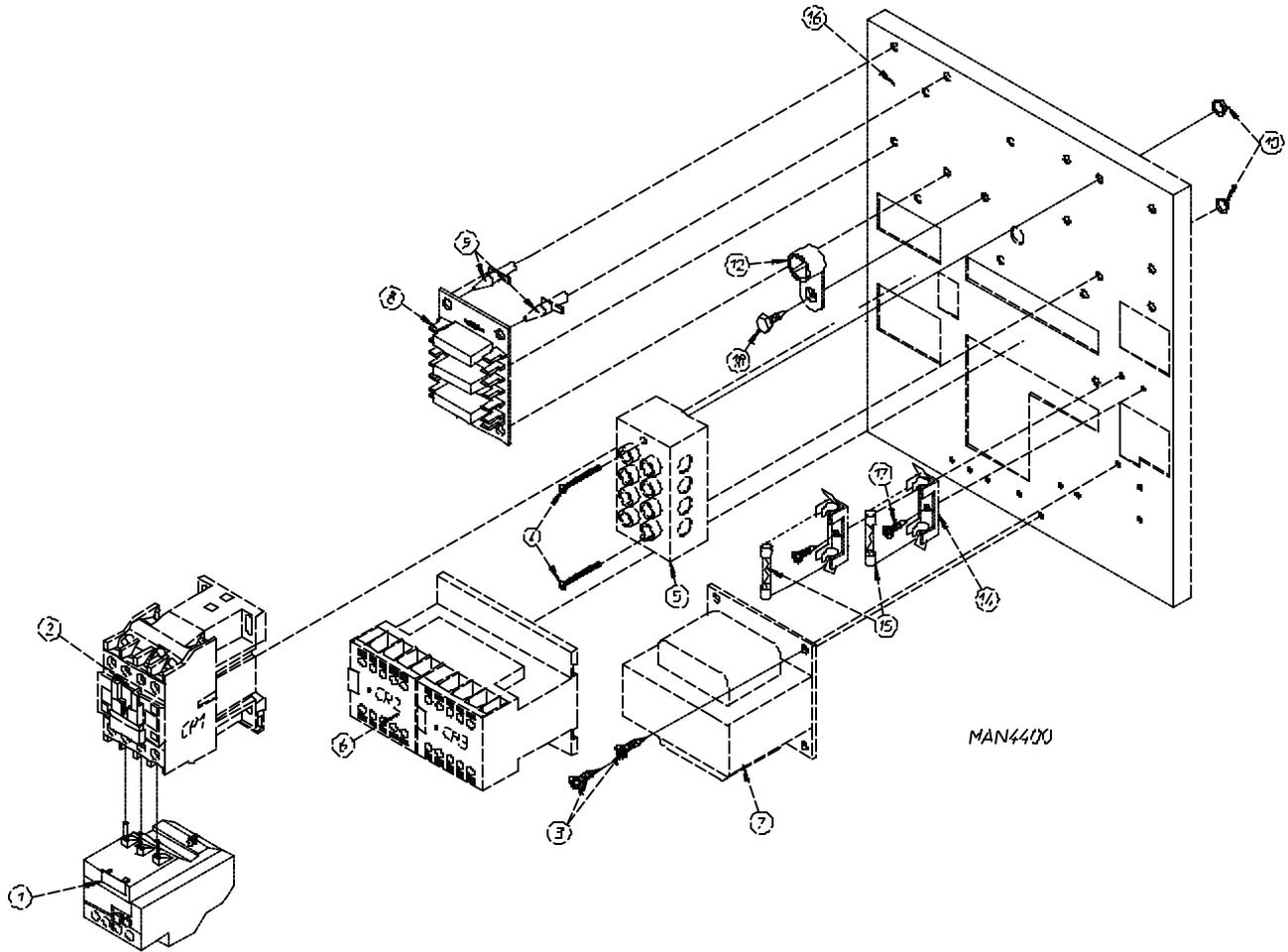

Illus. No.	Part No.	Qty.	Description
1	132467	1	9-13-Amp Overload (208-240 Volt)
2	132445	1	24 VAC 3-Phase (3 ϕ) Contactor
3	150300	2	#10-16 x 1/2" Hex Washer TEK Screw
4	150008	2	#6-32 x 1-1/4" Phillips Round Head Machine Screw
5	120701	1	4-Position Terminal Block
6	132448	1	Reversing Contactor
7	842894	1	208-240 Volt Transformer Assembly
8	137060	1	Arc Suppressor (A.S.) Board
9	137013	4	Nylon Standoff
10	151000	2	#6-32 Pal Nut
11	152004	1	5/16-18 Pal Nut
12	121010	1	L-70 Ground Lug
13	153002	1	5/16" Lock Washer
14	136008	2	Fuse Holder ONLY
15	136057	2	0.5-Amp (slo blo) Fuse ONLY
16	323743	1	Relay Panel ONLY
	835074	1	Reversing Relay Panel Assembly Complete (includes illus. nos. 1 through 18)
17	150301	2	#8-18 x 7/16" Phillips Pan Head TEK Screw
18	150297	1	#10 x 1/2" Hex Washer TEK Screw (green)

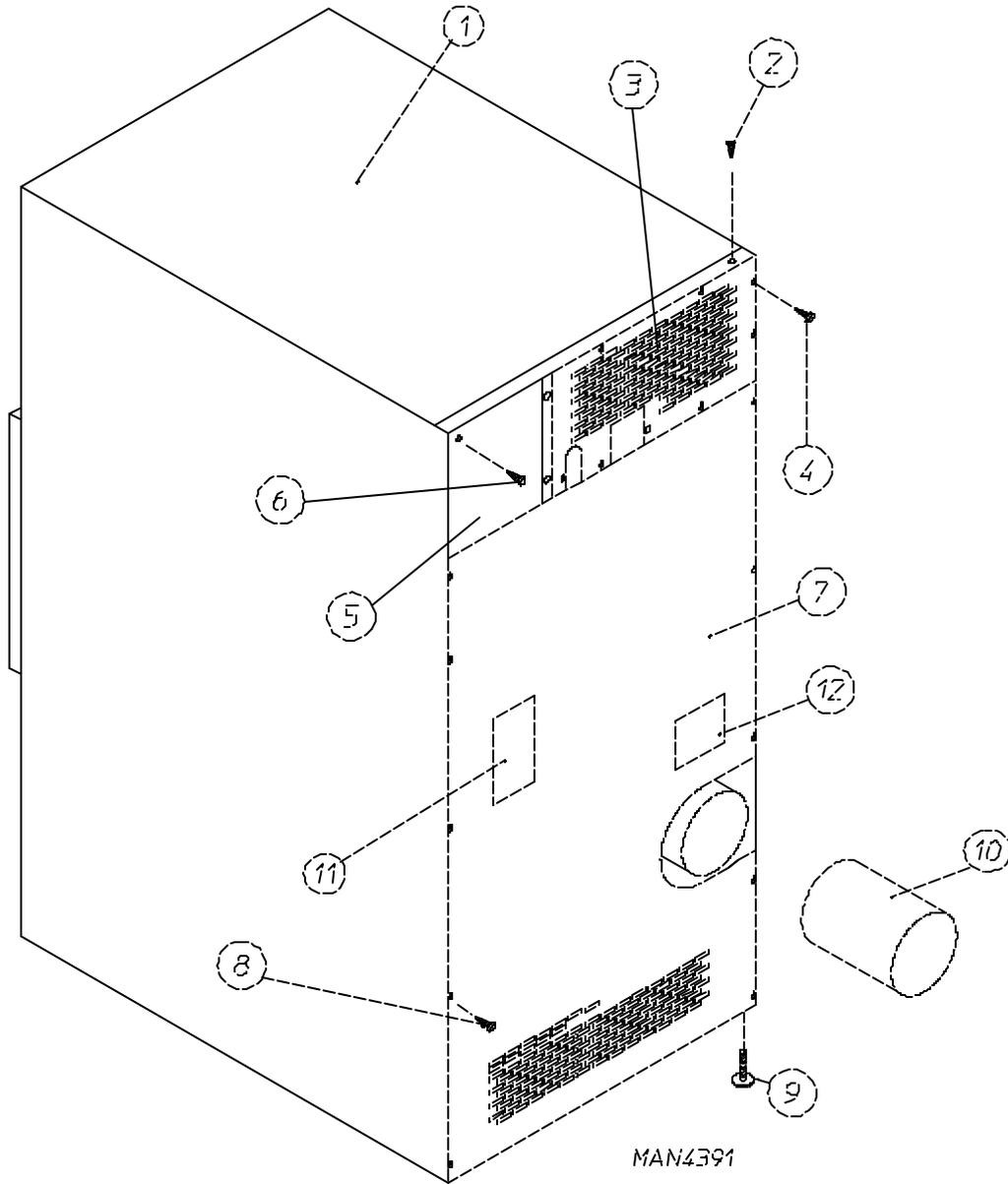

<u>Illus. No.</u>	<u>Part No.</u>	<u>Qty.</u>	<u>Description</u>
1	312527	1	Outer Top Assembly
2	150301	8	#8-18 x 7/16 Phillips Pan Head TEK Screw
3	323759	1	Top Back Guard Assembly (26-7/8" x 13-15/16")
4	150301	6	#8-18 x 7/16" Phillips Pan Head TEK Screw
5	323749	1	Rear Electrical Box Cover (10-13/16" x 9-3/4")
6	150301	6	#8-18 x 7/16" Phillips Pan Head TEK Screw
7	314511	1	Lower Back Guard
8	150301	10	#8-18 x 7/16" Phillips Pan Head TEK Screw
9	103500	4	Leveling Leg
10	882203	1	12" to 14" Exhaust Damper Increaser
11	112519	1	"Routine Maintenance Schedule" Label
12	114092	1	"Exhaust Transition Warning" Label

<u>Part No.</u>	<u>Description</u>
112075	“Ground Here” Label
112280	“Clean Lint Screen” Label
112804	Manometer (hydro gauge) For Measuring Gas Pressure
112284	“Phase 6 OPL Program Location Summary” Label
114001	“CAUTION - Exhaust/Lint Screen” Label
114006	“WARNING - Fire Hazards” Label
114051	“Phase A - B Factor” Label
117505	Aluminum Duct Tape (sold by the foot)
120100	3/8” Straight (BX) Connector
120301	1/2” x 45° (BX) Connector
120400	3/8” Red Jacket (BX) Insulator
120500	3/8” Jiffy Clip (BX Retainer Clip)
120600	3/8” Greenfield (BX)
120800	1/4” In-Line Connector
120802	Red Butt Connector
120902	#74B Wire Nut
120903	Crimp-On Wire Nut
121014	1/4” Insulated (female) Terminal
121499	4” Harness Tie
121500	7” Harness Tie
121503	Harness Tie Mounting Clip
404502	White Brush-In-Cap Bottle Touch-Up Paint
880884	Tumbler Bearing Puller
404507	Cornflower Blue Brush-In-Cap Bottle Touch-Up Paint
404513	Wrinkle Blue Brush-In-Cap Bottle Touch-Up Paint

ADC 450403 1- 04/13/99-50 2- 02/25/00-25 3- 05/12/00-35
4* 09/11/00-25

