



DN0030NC-10
DN0050NC-10
DN0080NC-10

Section 5:

Dryer Parts Data

Dryer Cabinet Group

Key	Description	T-30	T-50	T80	QTY
1	Loading Door Complete SS/ Brushed SS/Blk	9960-306-001	9960-305-001	9960-305-001	1
1	Loading Door Complete Wht/ Brushed SS/Blk	9960-306-003	9960-305-003	9960-305-003	1
2	Door Assy, Loading (Ring only) Brushed SS	9960-255-008	9960-284-002	9960-284-002	1
3	Plate Assy, Hinge (SS)	9982-374-001	9982-368-001	9982-368-001	1
3	Plate Assy, Hinge (Wht)	9982-374-003	9982-368-003	9982-368-003	1
*	Cover-Hinge Back, Black	9074-341-002	9074-340-002	9074-340-002	1
*	Screw-10Bx3/8, Black	9545-008-010	9545-008-010	9545-008-010	2
*	Screw Hinge to Door	9545-012-015	9545-012-015	9545-012-015	4
*	Nut, Hinge to Door	8640-413-002	8640-413-002	8640-413-002	4
4	Glass, Door	9212-002-003	9212-002-004	9212-002-004	1
5	Gasket, Door Glass (Black)	9206-413-001	9206-413-002	9206-413-002	1
*	Support Door Glass	9548-117-000	9548-117-000	9548-117-000	2
6	Gasket, Door Outer Rim (Black)	9206-420-003	9206-420-005	9206-420-005	1
7	Handle, Loading Door	9244-082-001	9244-082-001	9244-082-001	1
*	Screw, Handle	9545-018-017	9545-018-017	9545-018-017	2
8	Stud Door Catch	9531-033-002	9531-033-002	9531-033-002	1
9	Nut-Hex, #10-32	8640-413-001	8640-413-001	8640-413-001	1
10	Nut, Acorn	8640-413-003	8640-413-003	8640-413-003	1
*	Catch, Loading Door	9086-015-002	9086-015-002	9086-015-002	2
*	Rivit	8638-190-009	8638-190-009	8638-190-009	4
11	Strap, Hinge (Black)	9966-018-002	9966-014-002	9966-014-002	1
*	Plate Assy-Backup, Hinge	9982-386-001	9982-356-001	9452-790-001	2
*	Plate Assy-Backup, Hinge			9982-369-001	1
*	Reinforcement-Front panel			9817-003-001	1
12	Screw-Phillips, 10-32x1/2 Chrome	9545-012-003		9545-012-003	8
*	Screw-Phillips-Counter sink, 10- 32x1/2 Chrome	NA		9545-012-028	4
13	Screw-Special, Hinge to Door	9545-052-001	9545-052-001	9545-052-001	1
*	Nut-Allen, 1/4-20	8640-439-001	8640-439-001	8640-439-001	1
14	Washer-Fiber/Plastic	8641-436-003	8641-436-003	8641-436-003	1
15	Front Panel Assy (SS)	9454-918-001	9454-866-001	9454-868-001	1
15	Front Panel Assy (Wht)	9454-918-003	9454-866-003	9454-868-003	1
16	Screw-Phillips, 10Bx1 3/4	9545-008-014	9545-008-014	9545-008-014	4
17	Washer-Finish	8641-585-001	8641-585-001	8641-585-001	4
*	Nut-Spring	8640-399-001	8640-399-001	8640-399-001	4
*	Insulation-Front Panel, Top Half	9277-063-001	9277-057-001	9277-058-001	1
*	Insulation-Front Panel, Bottom Half	9277-063-002	9277-057-002	9278-058-002	1
18	Label-Warning	8502-753-001	8502-753-001	8502-753-001	1
19	Plug-Front Panel	9456-050-001	9456-050-001	9456-050-001	1
*	Switch-Door (Round)	9539-492-001	9539-492-001	9539-492-001	1
*	Switch-Door (Square)	9539-501-001	9539-501-001	9539-501-001	1
*	Wire-Assy, Blk	8220-063-026	8220-063-026	8220-063-026	1
*	Wire-Assy-Blu	8220-063-009	8220-063-009	8220-063-009	1
*	Cover-Door Switch			9074-351-001	1
*	Nut-#10-32unf, 2B			8641-413-002	2

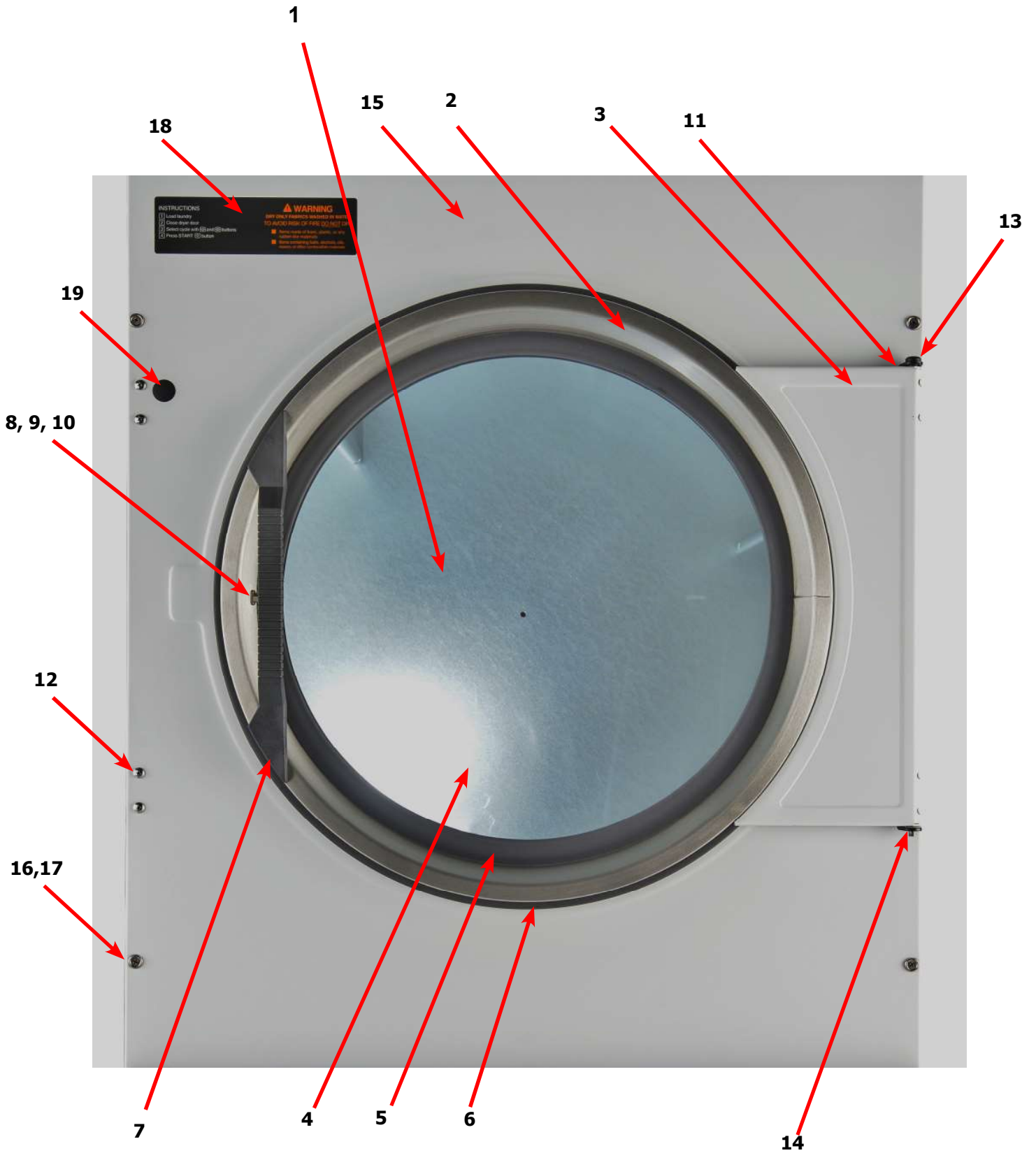

Dryer Cabinet Group Continued

Key	Description	T-30	T-50	T80	QTY
1	Nameplate - Dexter Dryer Black	9412-196-001	9412-196-001	9412-196-001	1
2	Door Assy-Upper, OPL (SS)	9960-288-001	9960-290-001	9960-292-001	1
2	Door Assy-Upper, OPL (Wht)	9960-288-003	9960-290-003	9960-292-003	1
*	Bracket-Hinge	9029-224-001	9029-224-001	9029-224-001	2
*	Rivit- 3/16, Hinge to Door	9491-009-001	9491-009-001	9491-009-001	2
*	Rivit- 3/16, Hinge to Cabinet	9491-009-001	9491-009-001	9491-009-001	AR
3	Trim-Upper Service Door, Black	9578-098-002	9578-094-002	9578-096-002	1
4	Screw-Phillips, 10Bx3/8, Black	9545-008-010	9545-008-010	9545-008-010	4
5	Screw-Phillips, 10Bx1 3/4	9545-008-014	9545-008-014	9545-008-014	2
6	Washer-Finish	8641-585-001	8641-585-001	8641-585-001	2
*	Nut-Spring	8640-399-001	8640-399-001	8640-399-001	2
7	Membrane Switch	9801-104-001	9801-104-001	9801-104-001	1
8	Kit-30/50/80 OPL, PCB-Controler	9732-249-001	9732-249-001	9732-249-001	1
*	Spacer-#6 x 1/2	9538-157-016	9538-157-015	9538-157-015	4
9	Nut- #6-32	8640-411-003	8640-411-003	8640-411-003	4
10	Wire Assy-GRN, 24"	8220-137-001	8220-137-001	8220-137-001	1
11	Fuse, .600MA/250V	8636-024-001	8636-024-001	8636-024-001	1
12	Support-Upper Service Door	9548-288-001	9548-288-001	9548-288-001	1
13	Clamp-Tube	9079-121-002	9079-121-002	9079-121-002	2
14	Nut, #6-32	8640-411-003	8640-411-003	8640-411-003	2
15	Clamp-Cable, 1/2"	8654-125-006	8654-125-006	8654-125-006	1
16	Nut, #6-32	8640-411-003	8640-411-003	8640-411-003	1
17	Insulation	9277-041-016	9277-041-016	9277-041-016	1
*	Harness-Control	9627-770-001	9627-770-001	9627-770-001	1
*	Harness-Temp Probe	9627-679-002	9627-679-002	9627-679-002	1

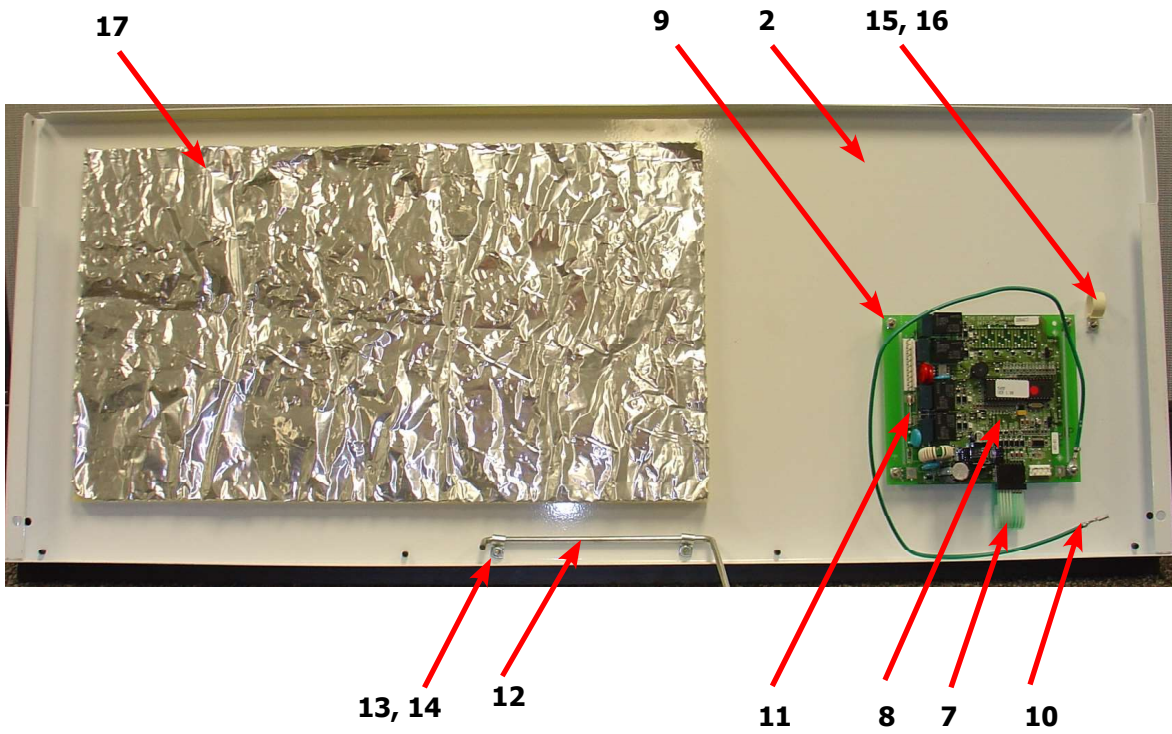

Dryer Cabinet Group Continued

Key	Description	T-30	T-50	T80	QTY
1	Door-Lower Service, OPL, SS	9108-131-001	9108-123-001	9108-127-001	1
1	Door-Lower Service, OPL, Wht	9108-131-003	9108-123-003	9108-127-003	1
2	Handle-Door, Lower Service, Black	9244-089-002	9244-087-002	9244-088-002	1
3	Screw-Phillips, 10Bx3/8, Black	9545-008-010	9545-008-010	9545-008-010	5
4	Handle-Door, Lower Service OPL	9244-084-002	9244-084-002	9244-084-002	1
5	Trim-Lower Kick, Black	9578-099-002	9578-095-002	9578-097-002	1
6	Screw-Phillips, 10Bx3/8, Black	9545-008-010	9545-008-010	9545-008-010	4
7	Screen Assy, Lint	9822-026-002	9822-026-001	9822-031-002	1
8	Switch-Door (Round)	9539-492-001	9539-492-001	9539-492-001	
*	Switch-Door (Square)	9539-501-001	9539-501-001	9539-501-001	1
9	Hinge-Door, Lower	9243-081-001	9243-082-001	9243-082-001	1
10	Screw-5/16, 10ABx3/8	9545-008-024	9545-008-024	9545-008-024	5
11	Bracket-Door Switch	9029-226-001	9029-226-001	9029-226-001	1
*	Rivit, 1/8 Low Profile	9491-009-004	9491-009-004	9491-009-004	2
12	Bracket-Chain	9029-233-001	9029-233-001	9029-233-001	2
*	Rivit, 1/8 Low Profile	9491-009-004	9491-009-004	9491-009-004	8
13	Hook, "S" Type	9248-022-002	9248-022-002	9248-022-002	4
14	Chain-Lower Service Door	9099-012-006	9099-012-006	9099-012-006	2

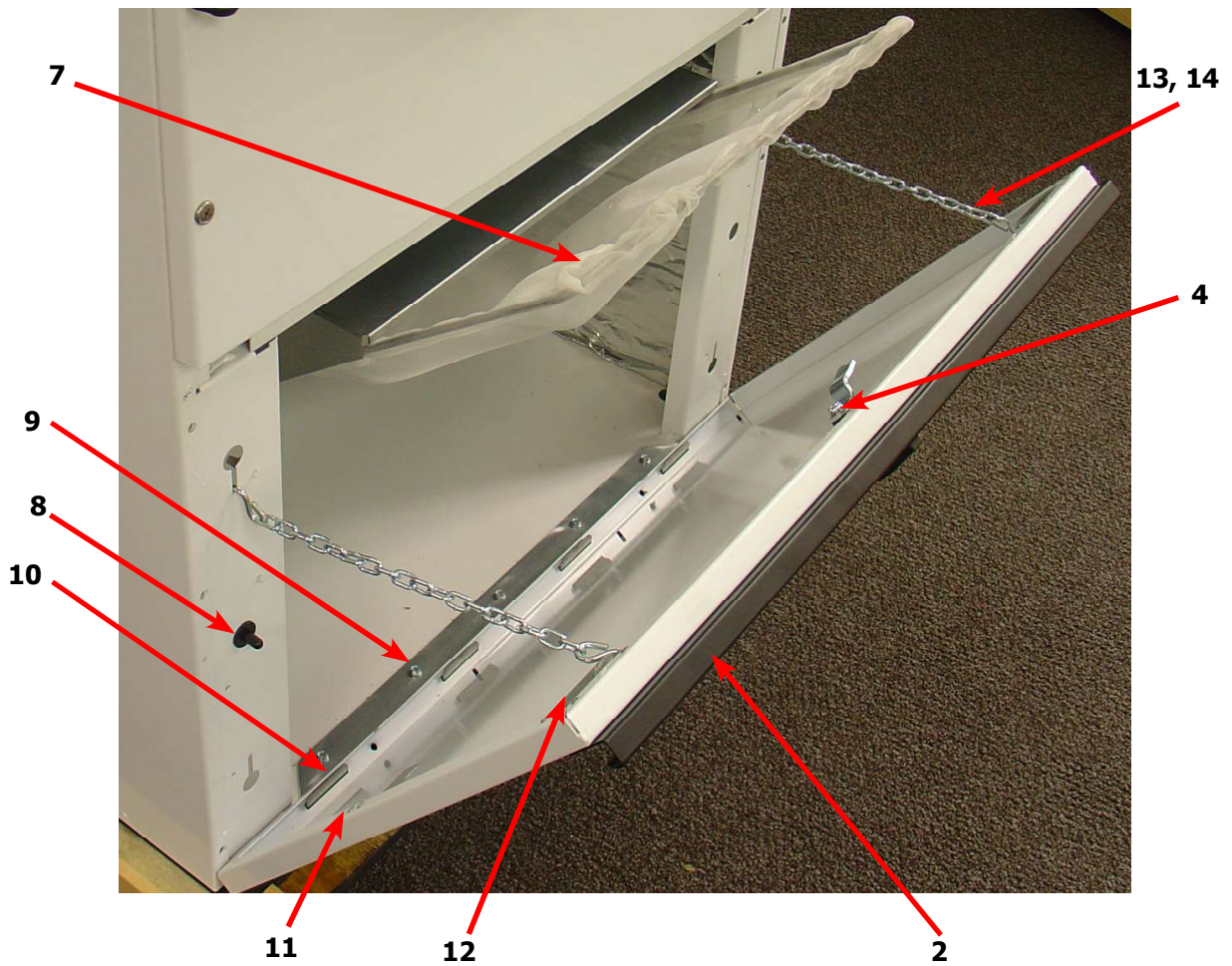
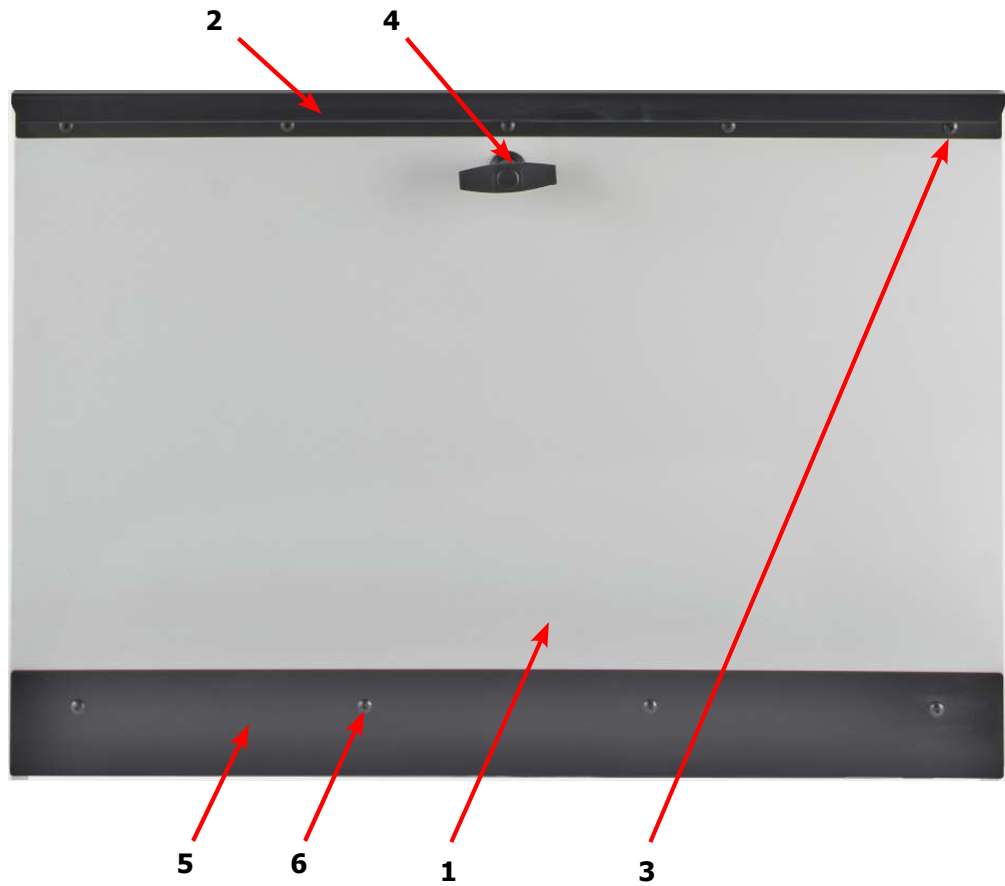

Dryer Cabinet Group Continued

Key	Description	T-30	T-50	T80	QTY
1	Insulation, Upper service Door	9277-041-006	9277-041-016	9277-041-016	1
2	Insulation, RH Burnner	9277-041-019	9277-041-023	9277-041-023	1
3	Insulation Tumbler Area, above Baffel	9277-041-020	9277-041-023		2
3	Insulation Tumbler Area, above Baffel		9277-041-023	9277-041-021	
4	Insulation Tumbler Area, below baffel	9277-041-020	9277-051-003		2
4	Insulation Tumbler Area, below baffel		9277-051-003	9277-041-004	2
4	Insulation Tumbler Area, below baffel			9277-041-004	6
5	Insulation Lint Compartment	9277-041-021	9277-041-024	9277-041-025	2
*	Screen Assy, Lint	9822-026-002	9822-026-001	9822-031-002	1
6	Switch-Door (Round)	9539-492-001	9539-492-001	9539-492-001	1
*	Switch-Door (Square)	9539-501-001	9539-501-001	9539-501-001	1
7	Hinge-Door, Lower	9243-081-001	9243-082-001	9243-082-001	1
8	Screw-5/16, 10ABx3/8	9545-008-024	9545-008-024	9545-008-024	AR
9	Lint Hood-Back	9240-038-001	9240-041-001	9240-044-001	1
10	Nut Wizlock, 8-32	8640-412-004	8640-412-004	8640-412-004	6
11	Lint hood, LH	9240-040-001	9240-043-001	9240-046-001	1
12	Lint hood, RH	9240-040-002	9240-043-002	9240-046-002	1
13	Lint hood, Top	9240-039-001	9240-042-001	9240-045-001	1
14	Screw, 5/16- 10ABx3/8	9545-008-024	9545-008-024	9545-008-024	14
15	Impeller, w/set screws	9278-043-001	9278-038-004	9278-037-003	1
16	Harness -Temp Probe	9627-679-002	9627-679-002	9627-679-002	1
17	Wire Nut, #71B	8640-276-005	8640-276-005	8640-276-005	2
18	Bracket, Temp Probe	9029-197-001	NA	NA	1
19	Screw-5/16, 10ABx3/8	9545-008-024	NA	NA	1
20	Temp Probe	9501-004-002	9501-004-002	9501-004-002	1
21	Screw-Phillips, 8Bx1/4	9545-045-005	9545-045-005	9545-045-005	1

30lb Temp Probe

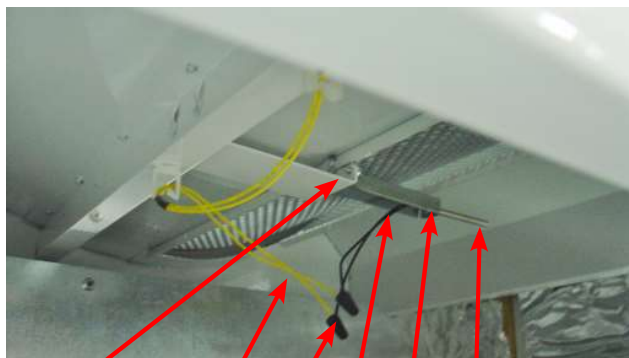

19 16 17 18 21 20

50Lb & 80Lb Temp Probe

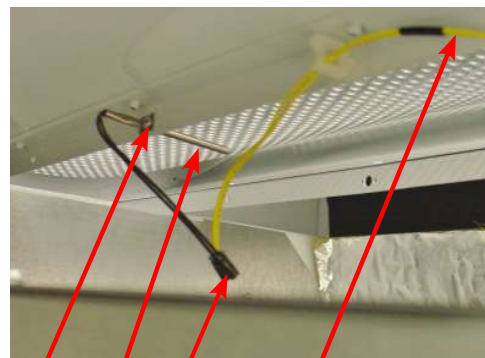

21 20 17 16

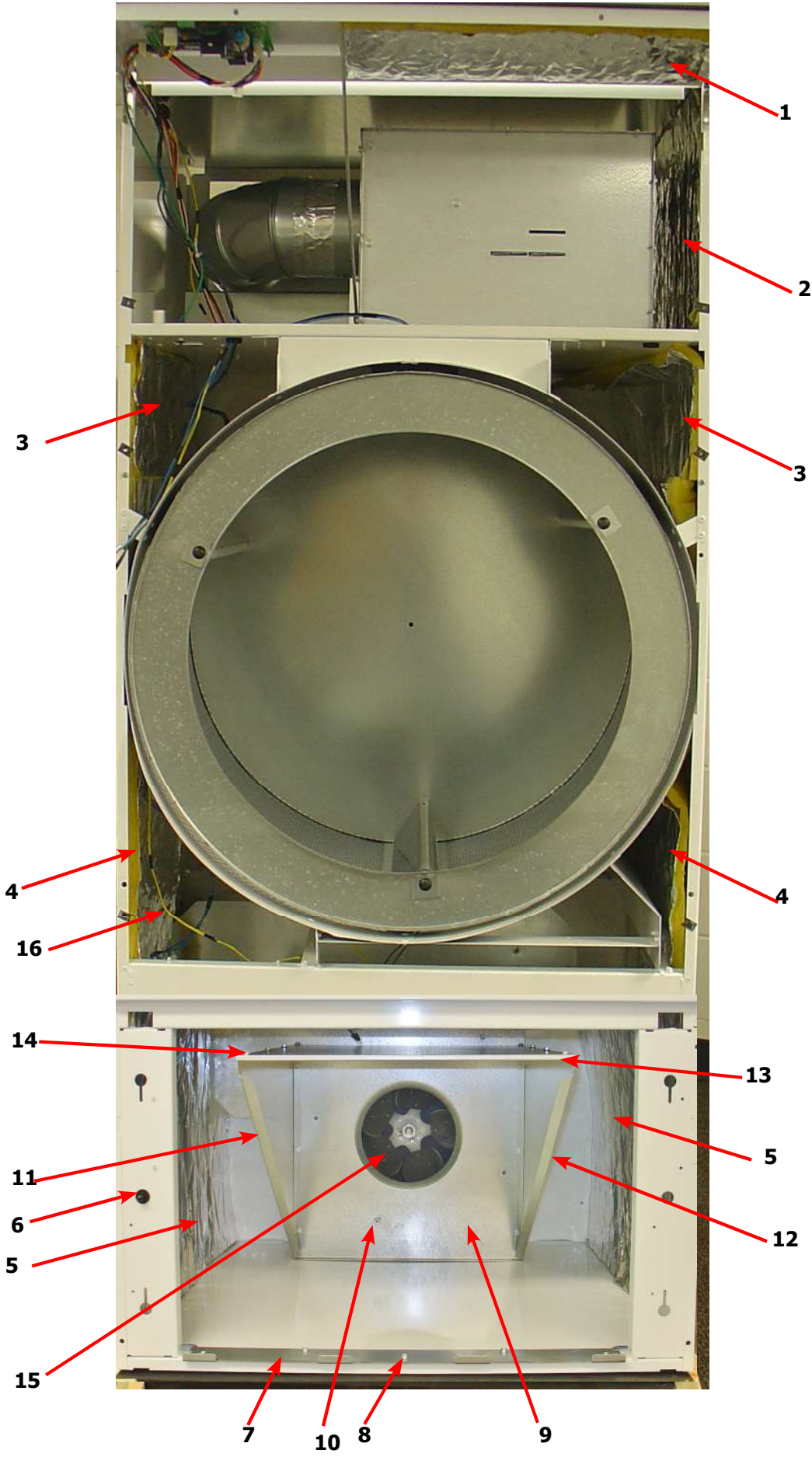

Dryer Rear View 30Lb

Key	Description	T-30	QTY
1	Motor	9376-311-003	1
2	Pulley	9453-157-001	1
*	Set screw	9545-028-013	1
3	Plate, Motor mounting	9982-370-002	1
*	Gasket, Motor Plate	9206-428-001	1
4	Nut-3/8-16, Plate to cabinet	8640-415-004	4
*	Impeller w/set screw	9278-043-001	1
5	Screw, 5/16-18x5/8	9545-014-004	4
6	Nut, 3/8-16	8640-415-004	4
7	Support Arm, Intermediate pulley	9991-053-001	1
8	Bolt- 3/8-16x1 1/4	9545-029-010	3
9	Nut, Wizlock, 3/8x16	8640-415-004	3
*	Cap Screw, 3/8-16x1 1/2	9545-029-003	1
*	Snap Ring	9487-200-003	1
*	Washer-Flat, 3/8x1	8641-581-035	1
10	Idler Arm Assembly	9861-022-001	1
11	Washer-Flat, 3/8x1	8641-581-035	2
12	Pulley, Idler w/Bearings	9908-039-004	1
13	Bearing, Bronze	9036-145-002	2
14	Snap Ring	9487-200-003	1
15	Hook "S" type	9248-022-002	3
16	Chain, Spring tension	9099-012-002	1
17	Spring, tension	9534-319-002	1
18	Chain, Limit	9099-012-007	1
19	Belt Drive	9040-076-003	1
*	Tolerance Ring	9487-234-005	1
20	Pulley, Driven	9908-049-002	1
21	Washer-Flat, 1/2	8641-581-021	1
22	Washer-Lock, Ext. tooth, 1/2	8641-582-016	1
23	Bolt-3/4, 1/2-13x1 1/4	9545-017-009	1
24	Belt, Driven	9040-073-009	1

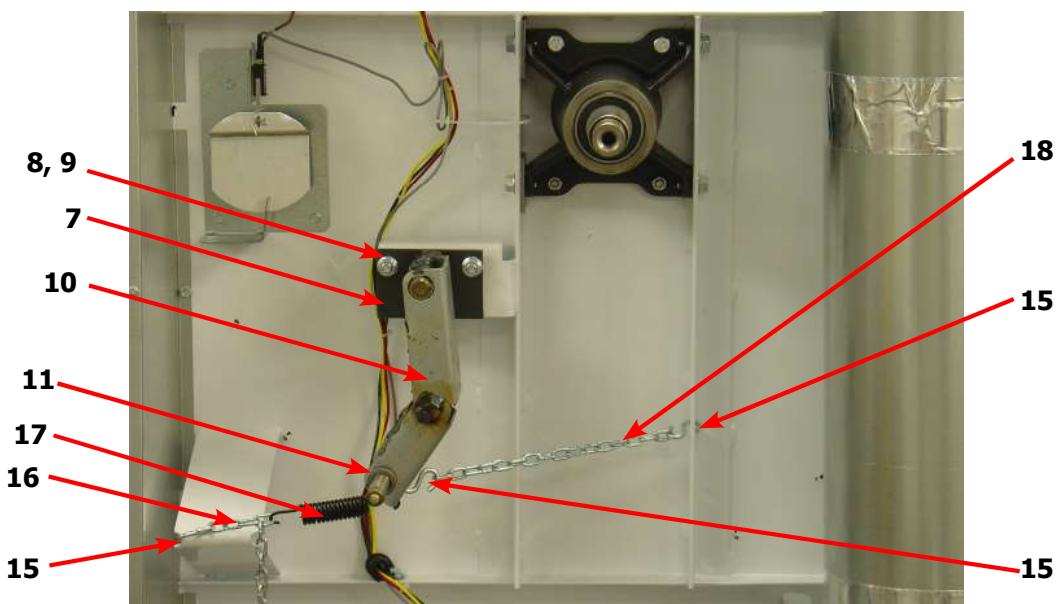

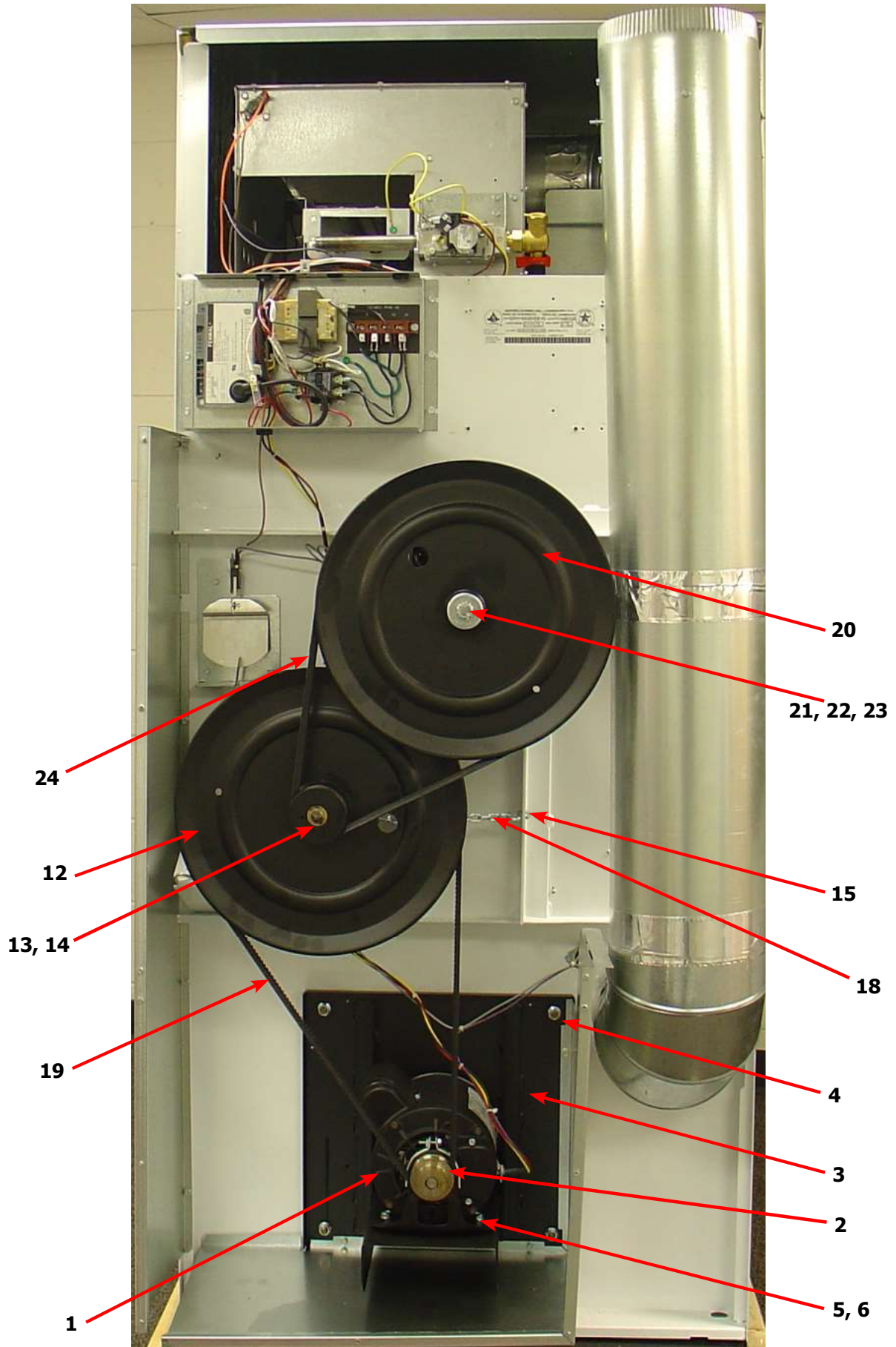

Key	Description	T-50	QTY
1	Motor	9376-317-003	1
2	Pulley	9453-169-013	1
*	Set screw	9545-028-013	1
3	Plate, Motor mounting	9982-370-002	1
*	Gasket, Motor Plate	9206-428-002	1
4	Nut-3/8-16, Plate to cabinet	8640-415-004	4
*	Impeller w/set screw	9278-038-004	1
5	Screw, 5/16-18x5/8	9545-014-004	4
6	Nut, 3/8-16	8640-415-004	4
7	Support Arm, Intermediate pulley	9991-053-002	1
8	Bolt- 3/8-16x1 1/4	9545-029-010	3
9	Nut, Wizlock, 3/8x16	8640-415-004	3
*	Cap Screw, 3/8-16x1 1/2	9545-029-012	1
*	Snap Ring	9487-200-003	1
*	Washer-Flat, 3/8x1	8641-581-035	1
10	Idler Arm Assembly	9861-022-002	1
*	Snap Ring (Support Arm keeper)	9487-200-003	1
*	Snap Ring	9487-200-003	1
*	Washer-Flat, 3/8x1	8641-581-035	1
11	Pulley, Idler w/Bearings	9908-048-003	1
12	Bearing, Bronze	9036-145-002	2
13	Snap Ring	9487-200-003	1
14	Hook "S" type	9248-022-002	3
15	Chain, Spring tension	9099-012-002	1
16	Spring, tension	9534-151-000	1
17	Belt Drive	9040-076-006	1
*	Tolerance Ring	9487-234-005	1
18	Pulley, Driven	9908-047-002	1
19	Washer-Flat, 1/2	8641-581-026	1
20	Washer-Lock, Ext. tooth, 1/2	8641-582-016	1
21	Bolt-3/4, 1/2-13x1/14	9545-017-009	1
22	Belt, Driven	9040-073-011	1
23	Thermostat-Overtemp, Reset	9576-207-006	1

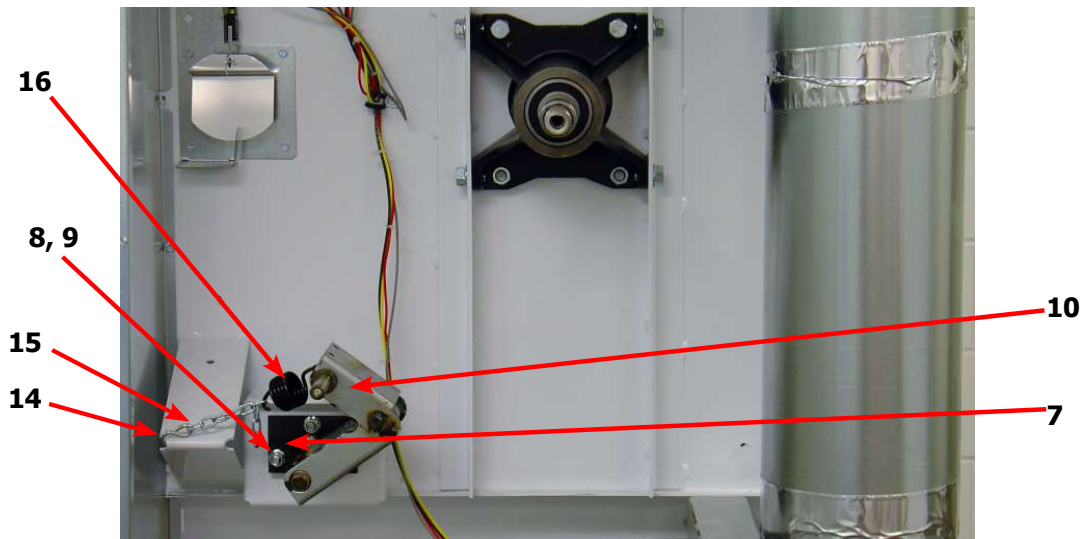

Dryer Rear View 50 Lb

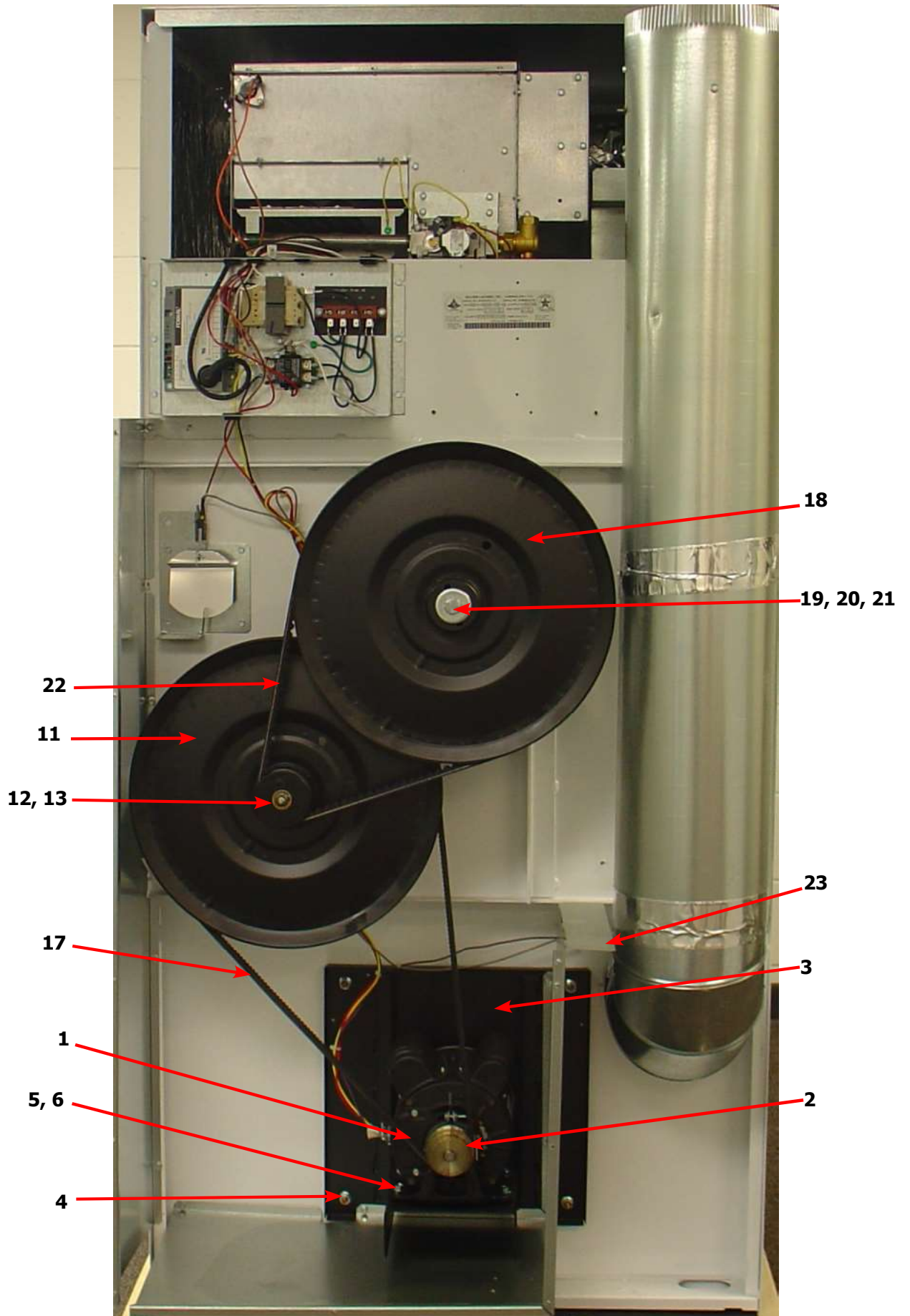

Key	Description	T-80	QTY
1	Motor	9376-317-003	1
2	Pulley	9453-157-001	1
*	Set screw	9545-028-013	1
3	Plate, Motor mounting	9982-372-002	1
*	Gasket, Motor Plate	9206-428-001	1
4	Nut-3/8-16, Plate to cabinet	8640-415-004	4
*	Impeller w/set screw	9278-037-003	1
5	Screw, 5/16-18x5/8	9545-014-004	4
6	Nut, 35/16-18	8640-400-003	4
*	Tolerance Ring	9487-234-001	1
7	Pulley, Driven	9908-043-002	1
8	Washer-Flat, 1/2	8641-581-026	1
9	Washer-Lock, Ext. tooth, 1/2	8641-582-016	1
10	Bolt-3/4, 1/2-13x1/14	9545-017-009	1
11	Support Arm, Intermediate pulley	9991-053-002	1
12	Bolt- 3/8-16x1 1/4	9545-029-010	3
13	Nut, Wizlock, 3/8x16	8640-415-004	3
*	Cap Screw, 3/8-16x1 1/2	9545-029-012	1
*	Snap Ring	9487-200-003	1
*	Washer-Flat, 3/8x1	8641-581-035	1
14	Idler Arm Assembly	9861-024-004	1
*	Snap Ring	9487-200-006	
*	Washer-Flat, 3/8x1	8641-581-039	1
15	Pulley, Idler w/Bearings	9908-042-006	1
*	Snapring, Inside-Bearing	9487-238-005	1
*	Bearing, Ball	9036-159-007	2
*	Spacer, Bearing	9538-173-002	1
16	Washer-Flat	8641-581-039	1
17	Nut, 5/8-11	8640-425-002	1
18	Hook "S" type	9248-022-002	3
19	Chain, Spring tension	9099-012-002	1
20	Spring, tension	9534-151-000	1
21	Belt Drive	9040-076-011	1
22	Belt, Driven	9040-073-012	1
23	Thermostat-Overtemp, Reset	9576-207-006	1

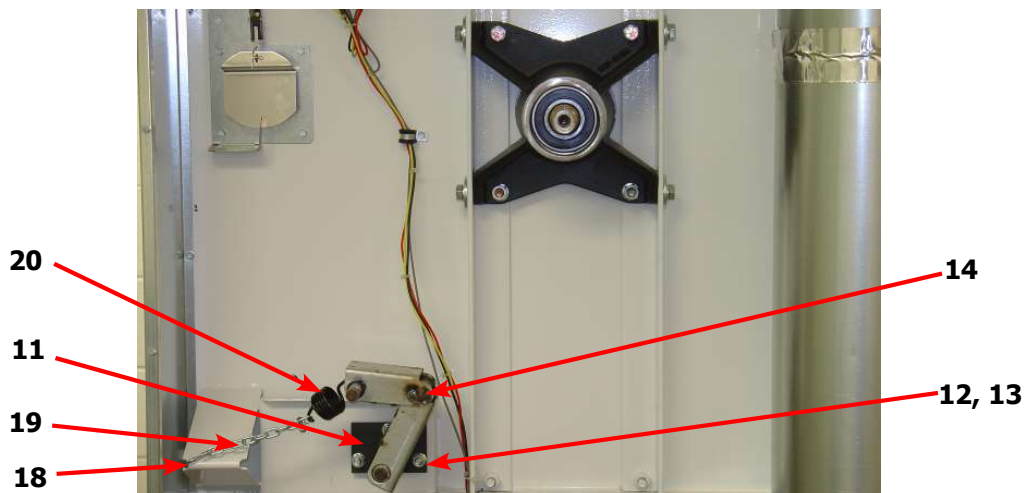

Dryer Rear View 80 Lb

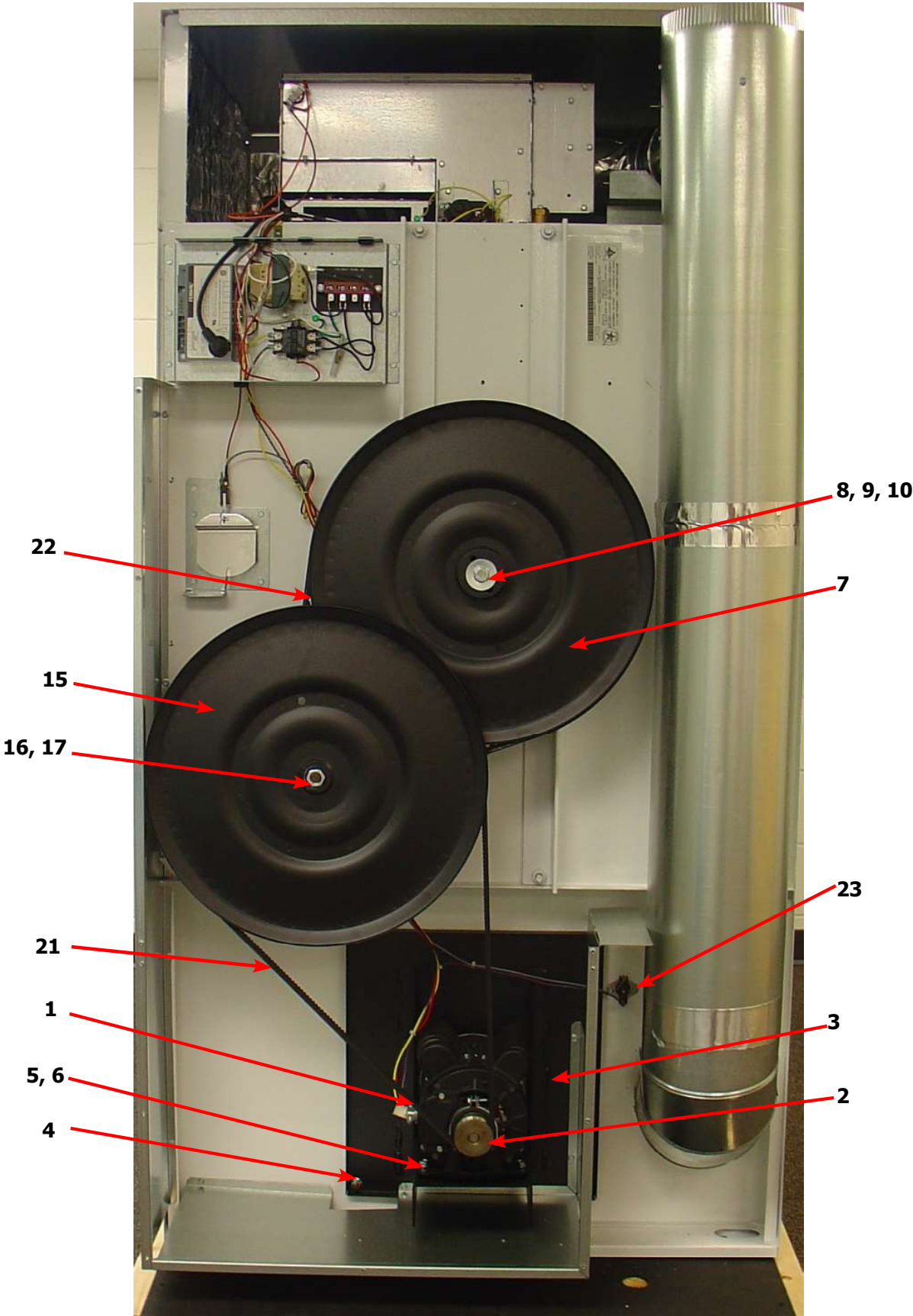

Dryer Rear View-Guard & Exhaust

Key	Description	T-30	T-50	T80	QTY
1	Cover Cabinet	9074-347-001	9074-348-001	9074-349-001	1
*	Screw-5/16, 10ABx3/8	9545-008-024	9545-008-024	9545-008-024	AR
2	Cover-Control Box	9074-346-001	9074-346-001	9074-346-001	1
3	Screw-5/16, 10ABx3/8	9545-008-024	9545-008-024	9545-008-024	AR
4	Guard, RH	9208-093-001	9208-097-001	9208-101-001	1
*	Screw-5/16, 10ABx3/8	9545-008-024	9545-008-024	9545-008-024	AR
5	Guard Base & LH	9208-094-001	9208-098-001	9208-102-001	1
*	Screw-5/16, 10ABx3/8	9545-008-024	9545-008-024	9545-008-024	AR
6	Guard-Lower	9208-095-001	9208-099-001	9208-103-001	1
7	Screw-5/16, 10ABx3/8	9545-008-024	9545-008-024	9545-008-024	AR
8	Guard-upper	9208-096-001	9208-100-001	9208-104-001	1
*	Screw-5/16, 10ABx3/8	9545-008-024	9545-008-024	9545-008-024	AR
9	Elbow-90 degree, 8"	9142-039-001	9142-039-001	9142-039-001	1
10	Pipe-Duct, 8"	9109-121-001	9109-121-001	9109-121-002	1
11	Tee-Duct, Recirculation, 8"-6"	9810-018-001	9810-018-001	9810-019-001	1
12	Damper	9125-002-001	9125-002-001	9125-008-001	1
*	Pin-Damper, Hinge	9451-146-002	9451-146-002	9451-146-002	1
*	Nut-Spring	8520-141-000	8520-141-000	8520-141-000	2
13	Bracket-Recirculation Duct, Small	9029-228-001	9029-228-001	9029-228-001	1
14	Pipe-Duct, 6"	9109-122-001	9109-122-002	9109-122-003	1
15	Bracket-Duct, Recirculation Large	9029-246-001	9029-247-001	9029-247-001	1
16	Elbow-90 degree, 6"	9142-039-002	9142-039-002	9142-039-002	1
*	Booklet-Owners	8514-208-001	8514-208-001	8514-208-001	1
17	Diagram & Schematics	9506-474-001	9506-474-001	9506-474-001	1
18	Label-Warning & Notice	8502-600-001	8502-600-001	8502-600-001	1
19	Label-Instructions	8502-645-001	8502-645-001	8502-645-001	1
20	Decal-Lighting & Clearance	8527-151-001	8527-151-001	8527-151-001	1
21	Label-High Voltage	8502-614-004	8502-614-004	8502-614-004	1

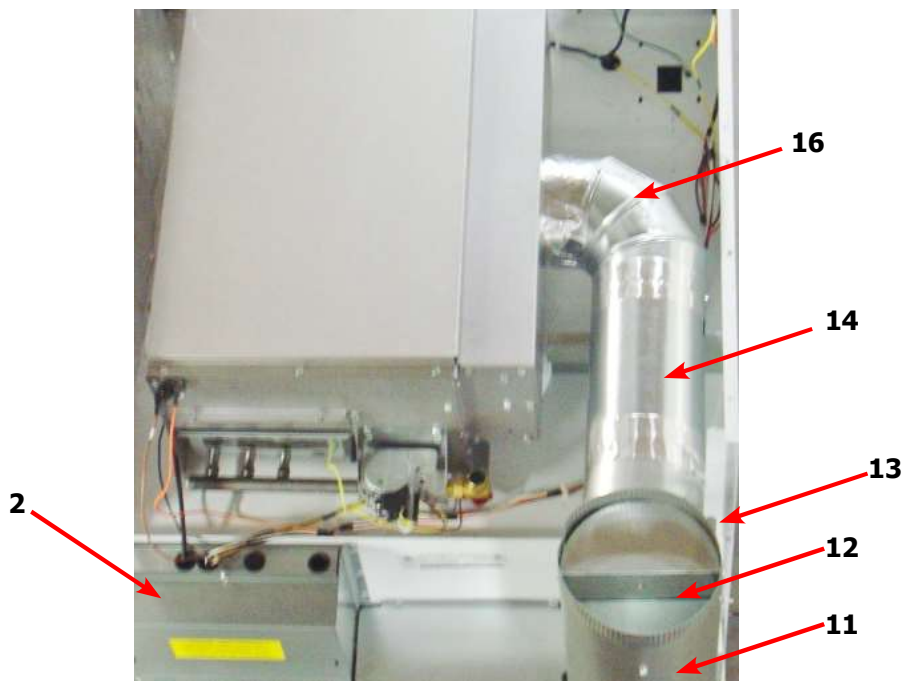

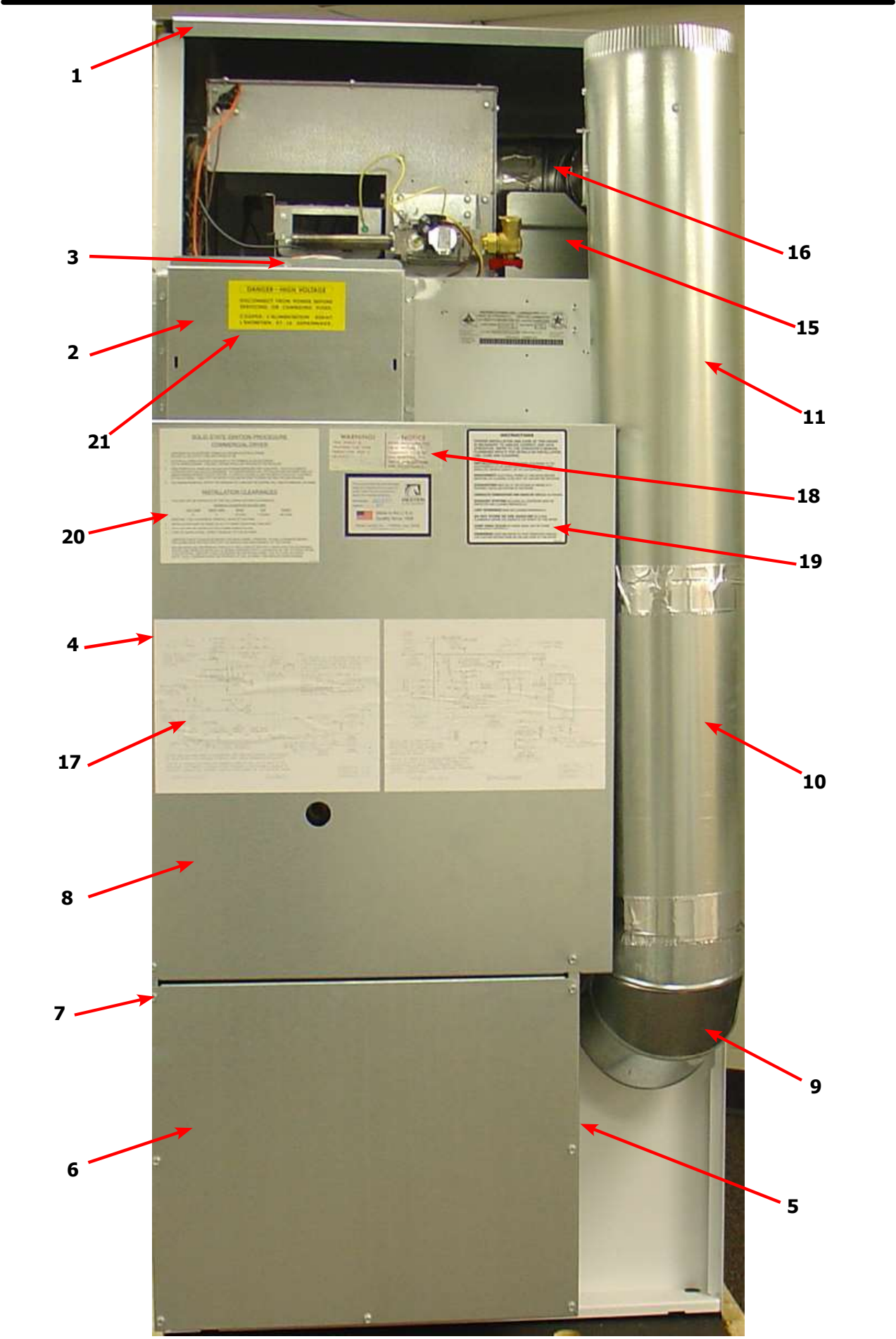

1

3

2

21

20

4

17

8

7

6

16

15

11

18

19

10

9

5

Dryer Rear View-Bearing Housing 30Lb

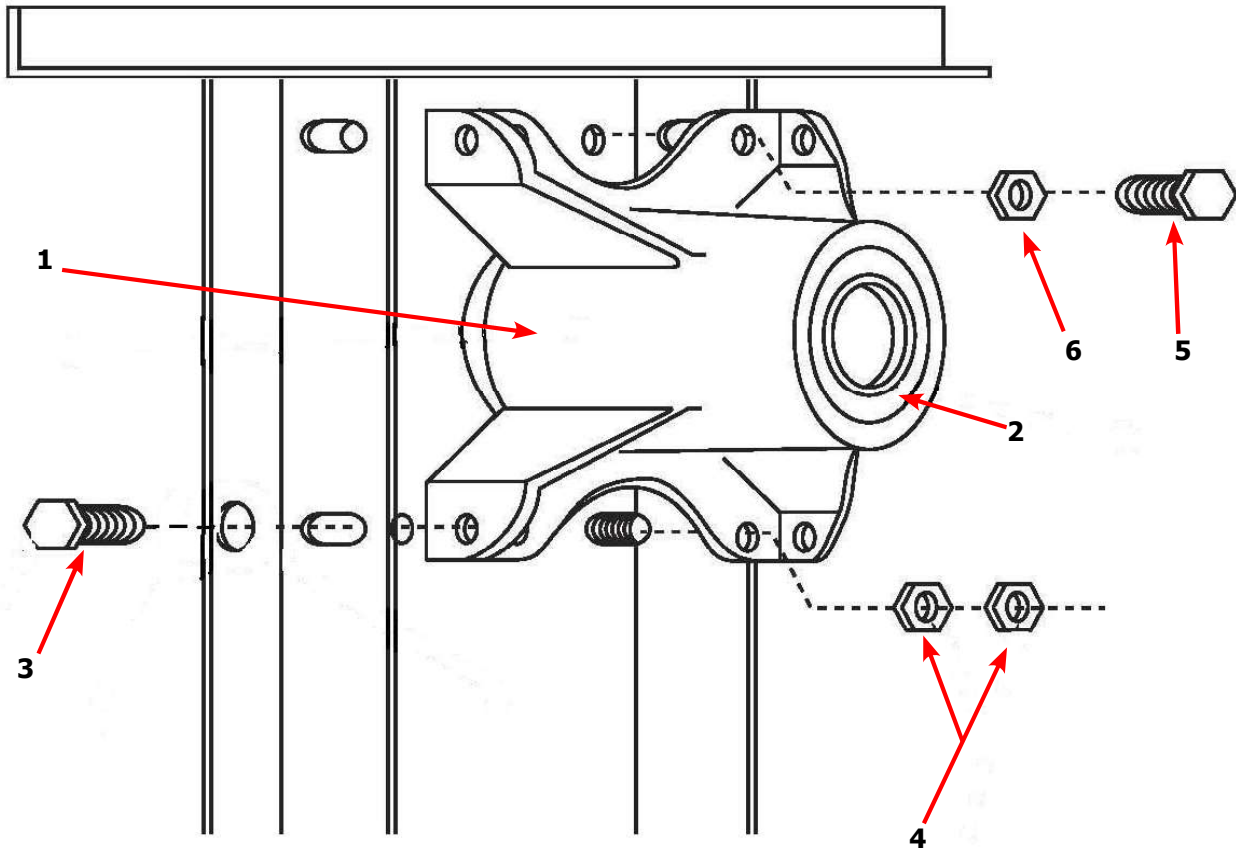

Key	Description	T-30	QTY
*	Bearing Housing Complete Assy (Includes bearings & Spacer)	9803-160-003	1
1	Housing, Bearing	9241-161-002	1
*	Bearing, Ball, Front	9036-130-001	1
*	Spacer, Bearing	9538-139-002	1
2	Bearing, Ball, Rear	9036-130-001	1
3	Screw-Wizlock, 3/8-24x3/4	9545-049-002	4
4	Nut, 5/16-18	8640-400-002	4
5	Screw, 3/8-24x1	9545-049-001	2
6	Nut, 3/8-24	8640-415-002	2
*	Shim, Tumbler	9538-139-002	AR

Dryer Tumbler Group 30Lb

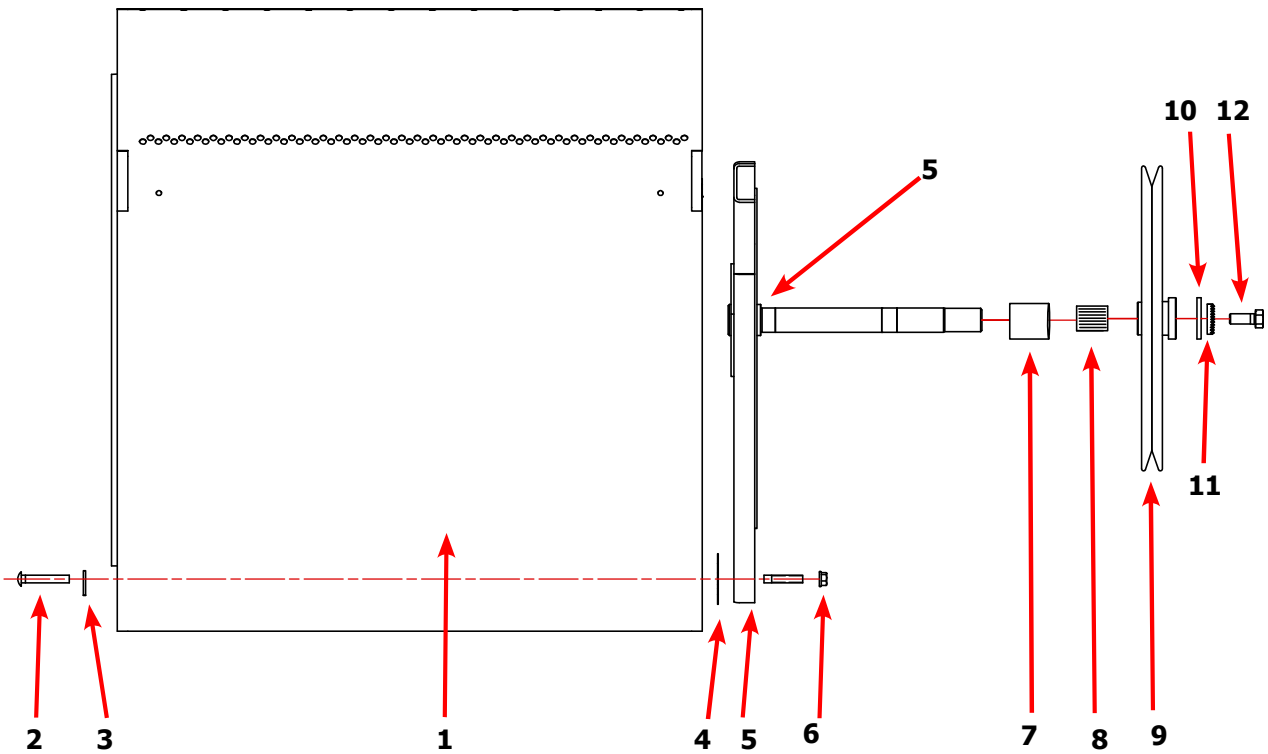

Key	Description	T-30	QTY
*	Tumbler Assy Complete W/Spider (GALV)	9848-147-001	1
1	Tumbler Assy (Galvanized)	9848-146-001	1
1	Tumbler Assy Complete W/Spider (SS & Galv front)	9848-147-002	1
1	Tumbler Assy (Stainless Galvanized front)	9848-146-002	1
2	Rod, Tumbler	9497-019-003	3
3	Washer, Special	8641-554-001	3
4	Shim	9552-013-000	AR
5	Spider Assy	9568-015-001	1
6	Nut, Wiz Lock	8640-415-004	3
7	Spacer-Shaft	9538-164-002	1
8	Tolerance Ring	9487-234-005	1
9	Pulley, Driven	9908-049-002	1
10	Washer -Flat	8641-581-026	1
11	LockWasher - IntTooth, 1"	8641-582-016	1
12	Screw, 1/2-13x1 1/4	9545-017-009	1

Dryer Rear View-Bearing Housing 50Lb

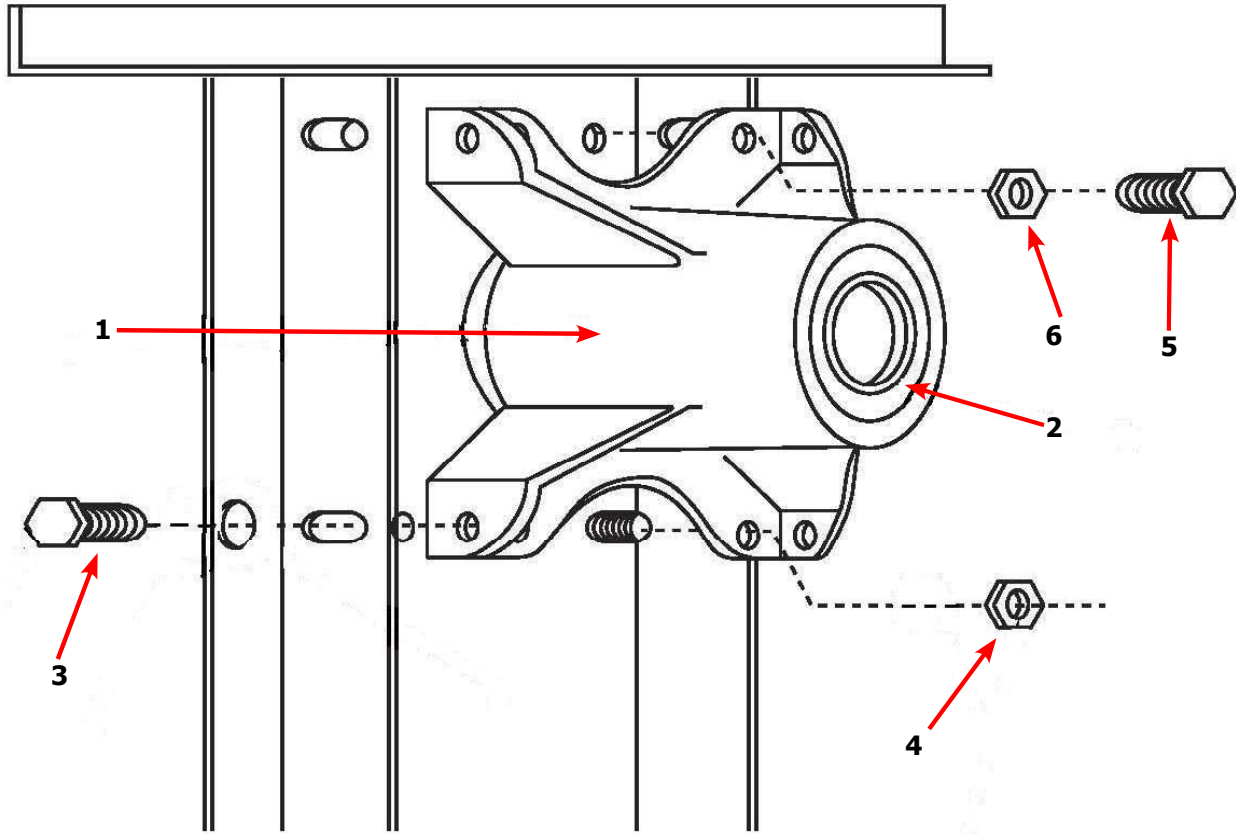

Key	Description	T-50	QTY
	Bearing Housing Complete Assy (Includes bearings & Spacer)	9803-201-001	1
1	Housing, Bearing	9241-189-002	1
*	Bearing, Ball, Front	9036-159-001	1
*	Spacer, Bearing	9538-183-001	1
2	Bearing, Ball, Rear	9036-159-003	1
3	Screw-Wizlock, 1/2-13x3/4	9545-017-017	4
4	Nut, 1/2-13	8640-417-002	2
5	Screw, 1/2-13x1 1/2	9545-017-018	2
6	Nut, 1/2-13	8640-417-002	2

Dryer Tumbler Group 50Lb

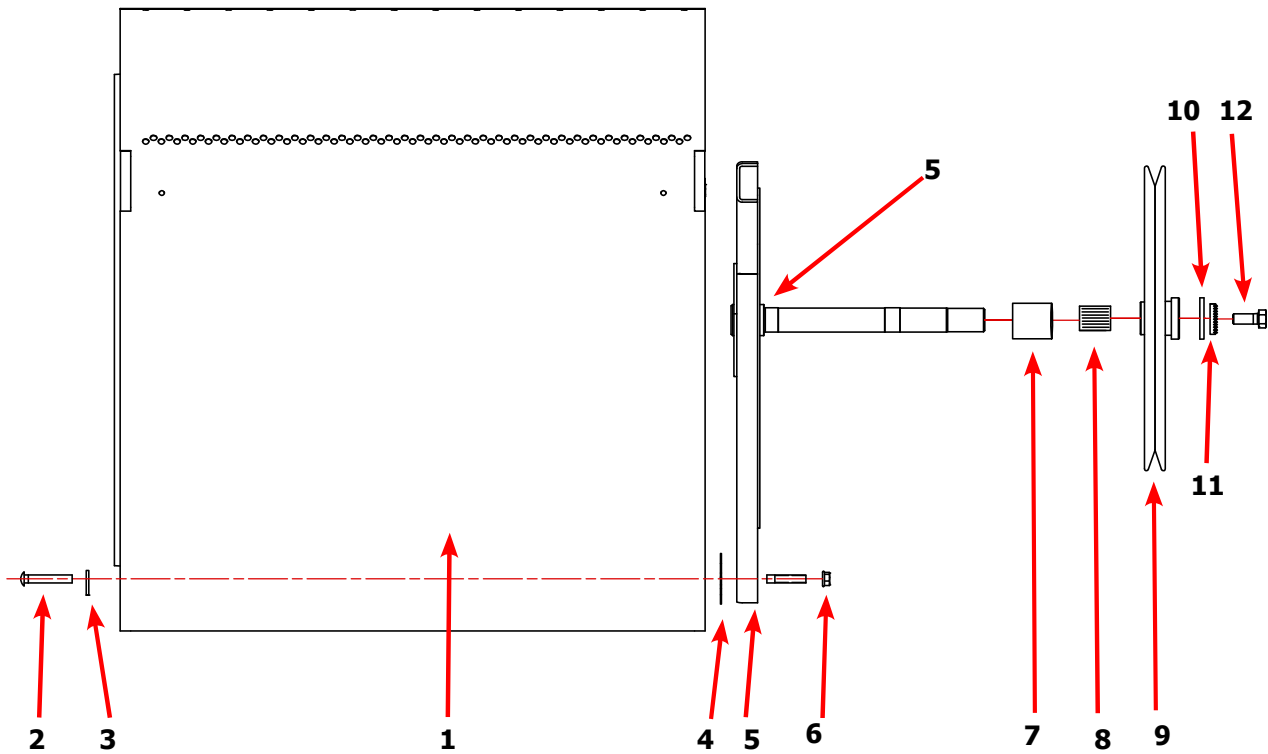

Key	Description	T-50	QTY
*	Tumbler Assy Complete W/Spider (GALV)	9848-149-001	1
1	Tumbler Assy (Galvanized)	9848-148-001	1
*	Tumbler Assy Complete W/Spider (SS & Galv front)	9848-149-002	1
1	Tumbler Assy (Stainless Galvanized front)	9848-148-002	1
2	Rod, Tumbler	9497-226-002	3
3	Washer, Special	8641-590-002	3
4	Shim	9552-013-000	AR
5	Spider Assy	9568-013-001	1
6	Nut, Wiz Lock	8640-417-005	3
7	Spacer-Shaft	9538-184-001	1
8	Tolerance Ring	9487-234-005	1
9	Pulley, Driven	9908-047-002	1
10	Washer -Flat	8641-581-026	1
11	LockWasher - IntTooth, 1"	8641-582-016	1
12	Screw, 1/2-13x1 1/4	9545-017-009	1

Dryer Rear View-Bearing Housing 80Lb

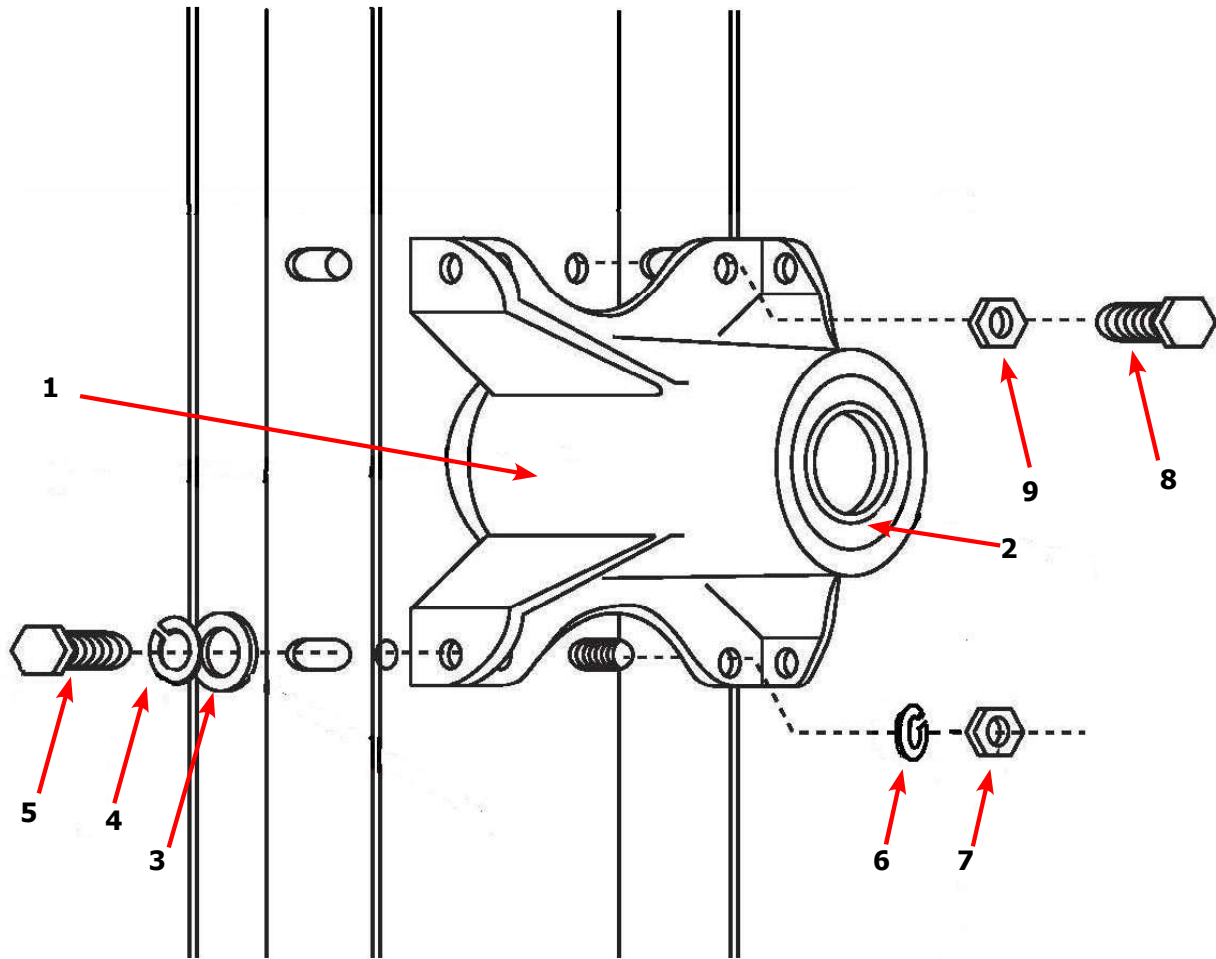

Key	Description	T80	QTY
	Bearing Housing Complete Assy (Includes bearings & Spacer)	9803-189-001	
1	Housing, Bearing	9241-183-003	
*	Bearing, Ball, Front	9036-159-001	
*	Spacer, Bearing		
2	Bearing, Ball, Rear	9036-159-002	
3	Washer, Flat 1/2	8641-581-026	
4	Lock Washer Spring, 1/2	8641-582-004	
5	Screw, 1/2-13x1	9545-017-004	
6	Lock Washer Spring, 1/2	8641-582-004	
7	Nut, 7/16-14	8640-416-001	
8	Screw, 7/16-14x1 1/2	9545-059-003	
9	Nut, 7/16-14	8641-416-001	

Dryer Tumbler Group 80Lb

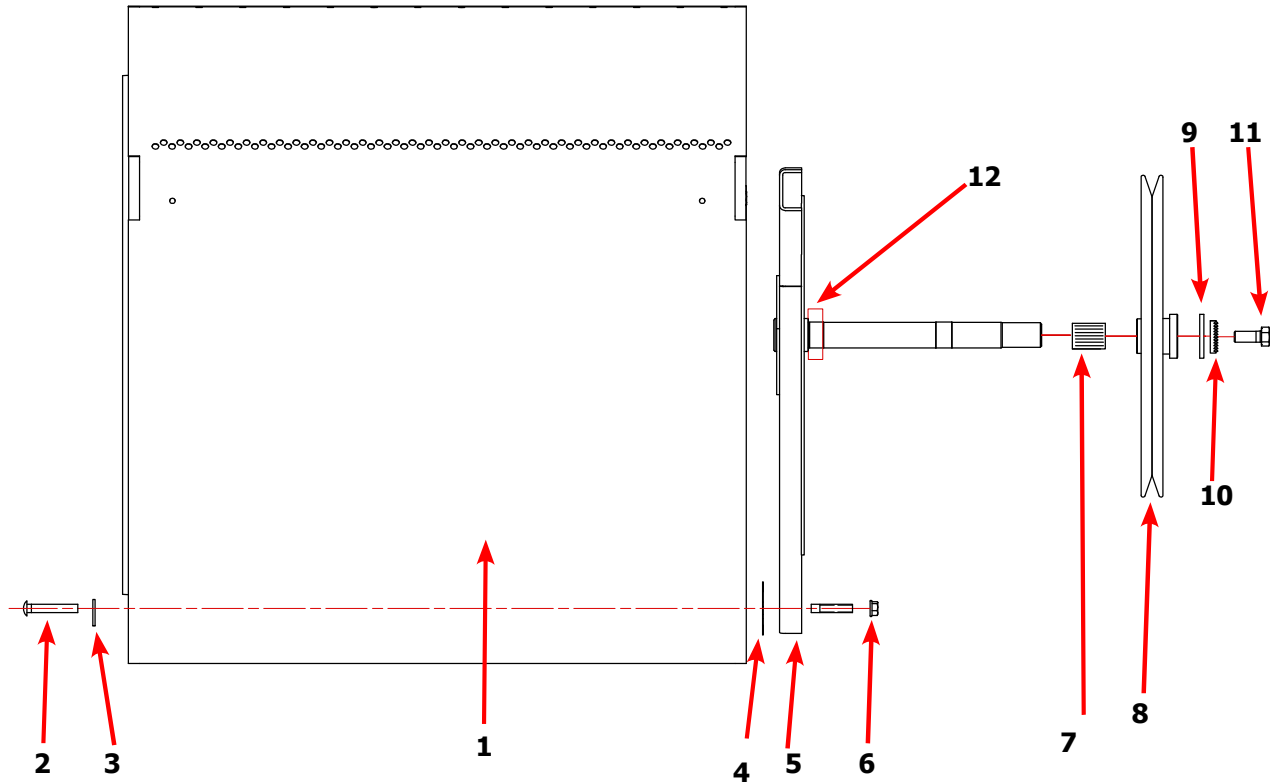

Key	Description	T80	QTY
*	Tumbler Assy Complete W/Spider (GALV)	9848-151-001	1
1	Tumbler Assy (Galvanized)	9848-150-001	1
1	Tumbler Assy Complete W/Spider (SS & Galv front)	9848-151-002	1
1	Tumbler Assy (Stainless Galvanized front)	9848-150-002	1
2	Rod, Tumbler	9497-266-001	4
3	Washer, Special	8641-590-001	4
4	Shim	9552-013-000	AR
5	Spider Assy w/Front Bearing	9873-008-001	1
6	Nut, Wiz Lock	8640-417-005	4
7	Tolerance Ring	9487-234-001	1
8	Pulley, Driven	9908-043-002	1
9	Washer -Flat	8641-581-026	1
10	LockWasher - IntTooth, 1"	8641-582-016	1
11	Screw, 1/2-13x1 1/4	9545-017-009	1
12	Bearing, Front	9036-159-002	1

Dryer Burner Housing Group 30Lb

Key	Description	Part Number	Qty
*	Housing Assembly, Burner	9803-210-001	1
1	Panel-Burner Housing, Side Left	9454-845-001	1
2	Baffle-Burner Housing, Center	9049-091-001	1
3	Panel-Burner Housing, Top	9454-871-001	1
4	Panel-Burner Housing, Front	9454-847-001	1
5	Panel-Burner Housing, Back	9454-848-001	1
6	Baffle-Burner Housing, Recirculation	9049-092-001	1
7	Baffle-Burner Housing, Front	9049-093-001	1
8	Duct Adaptor, 6"x3" long	9109-120-001	1
9	Burner, Main	9048-021-001	2
10	Bracket-Support, Electrode	9029-214-001	1
11	Bracket-Support, Gas Valve	9029-227-001	1
12	Electrode-Ignition	9875-002-003	1
13	Control Assy,Gas Valve, White Rodgers 36J	9857-192-001	1
14	Manifold Assy	9381-009-007	1
15	Valve-Gas Shutoff, (Optional)	9379-196-001	1
16	Thermostat-HI-Limit	9576-203-002	
17	Screw, 10ABx3/8	9545-008-024	24
18	Screw, 10ABx1/4	9545-008-001	17
19	Orfice-Natural, .125	9425-069-023	2
*	Orfice-LP, #48	9425-069-003	2
*	Kit, LP Conversion, White Rodgers	9732-102-018	1
20	Bracket-Support, Burner	9029-225-001	1
21	Panel-Burner Housing, Side Right	9454-861-001	1
22	Screw, 10-32TTx1/2 Green	9545-008-027	3
23	Screw, 8-32x3/8	9545-010-014	4

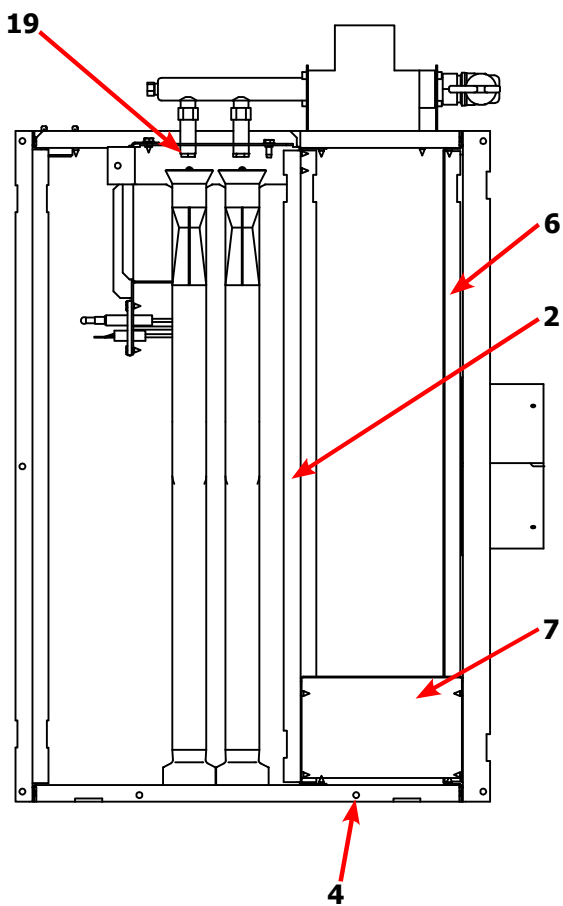
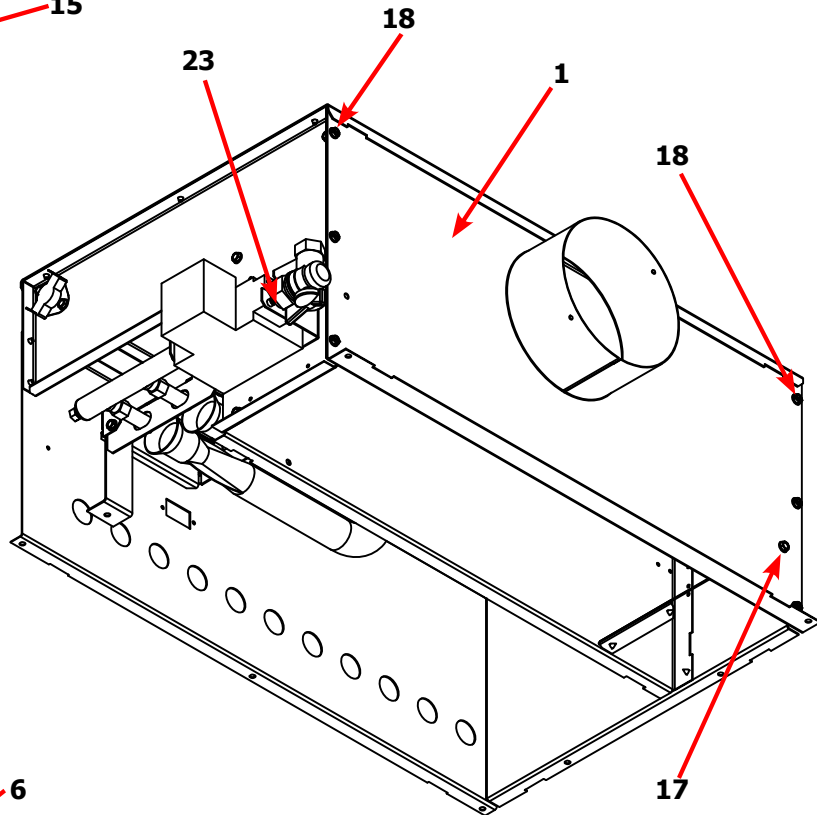
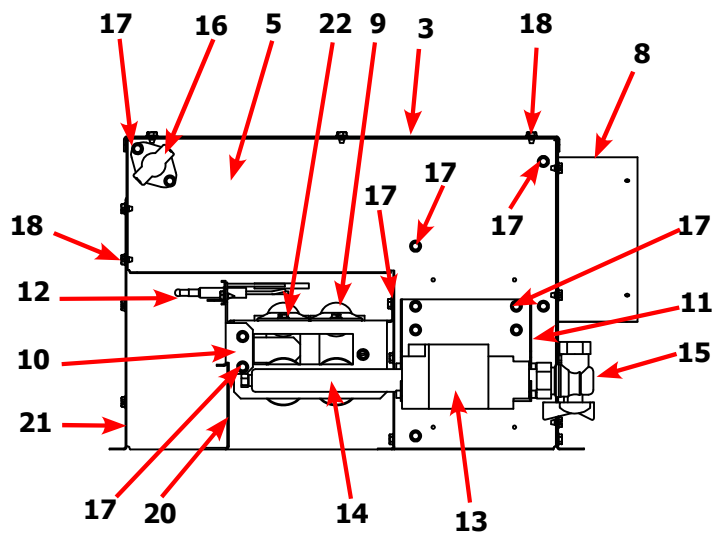

Dryer Burner Housing Group 50Lb

Key	Description	Part Number	Qty
	Housing Assembly, Burner	9803-211-001	1
1	Panel-Burner Housing, Front	9454-863-001	1
2	Panel-Burner Housing, Side Right	9454-861-001	1
3	Panel-Burner Housing, Side Left	9454-862-001	1
4	Panel-Burner Housing, Back	9454-864-001	1
5	Baffle-Burner Housing, Center	9049-098-001	1
6	Panel-Burner Housing, Top	9454-849-001	1
7	Panel-Burner Housing, Top	9074-343-001	1
8	Baffle-Burner Housing, Extention	9049-100-001	1
9	Duct Adaptor, 6"x1.25" long	9109-120-003	1
10	Baffle-Burner Housing, Recirculation	9049-099-001	1
11	Side-Extention Baffle, Burner Housing	9551-049-001	2
12	Bracket-Support, Burner	9029-213-001	1
13	Burner, Main	9048-021-001	3
14	Screw, 10T-32x1/2	9545-008-008	3
15	Electrode-Ignition	9875-002-003	1
16	Cover-Burner, Intet	9074-344-001	1
17	Bracket-Support, Gas Valve	9029-227-001	1
18	Control Assy,Gas Valve, White Rodgers 36J	9857-192-001	1
19	Screw, #8-32x3/8	9545-010-014	4
20	Valve-Gas Shutoff, (Optional)	9379-196-001	1
21	Manifold Assy	9381-010-003	1
*	Orfice-Natural, #30	9425-069-002	3
*	Orfice-LP, #48	9425-069-003	3
*	Kit, LP Conversion, White Rodgers	9732-102-017	1
23	Thermostat-HI-Limit	9576-203-002	1
24	Spacer-1/4x5/8 long	9538-166-009	2
25	Screw-8Bx1	9545-045-013	2
26	Screw, 10Bx1/4	9545-008-001	22
27	Screw, 10ABx3/8	9545-008-024	31

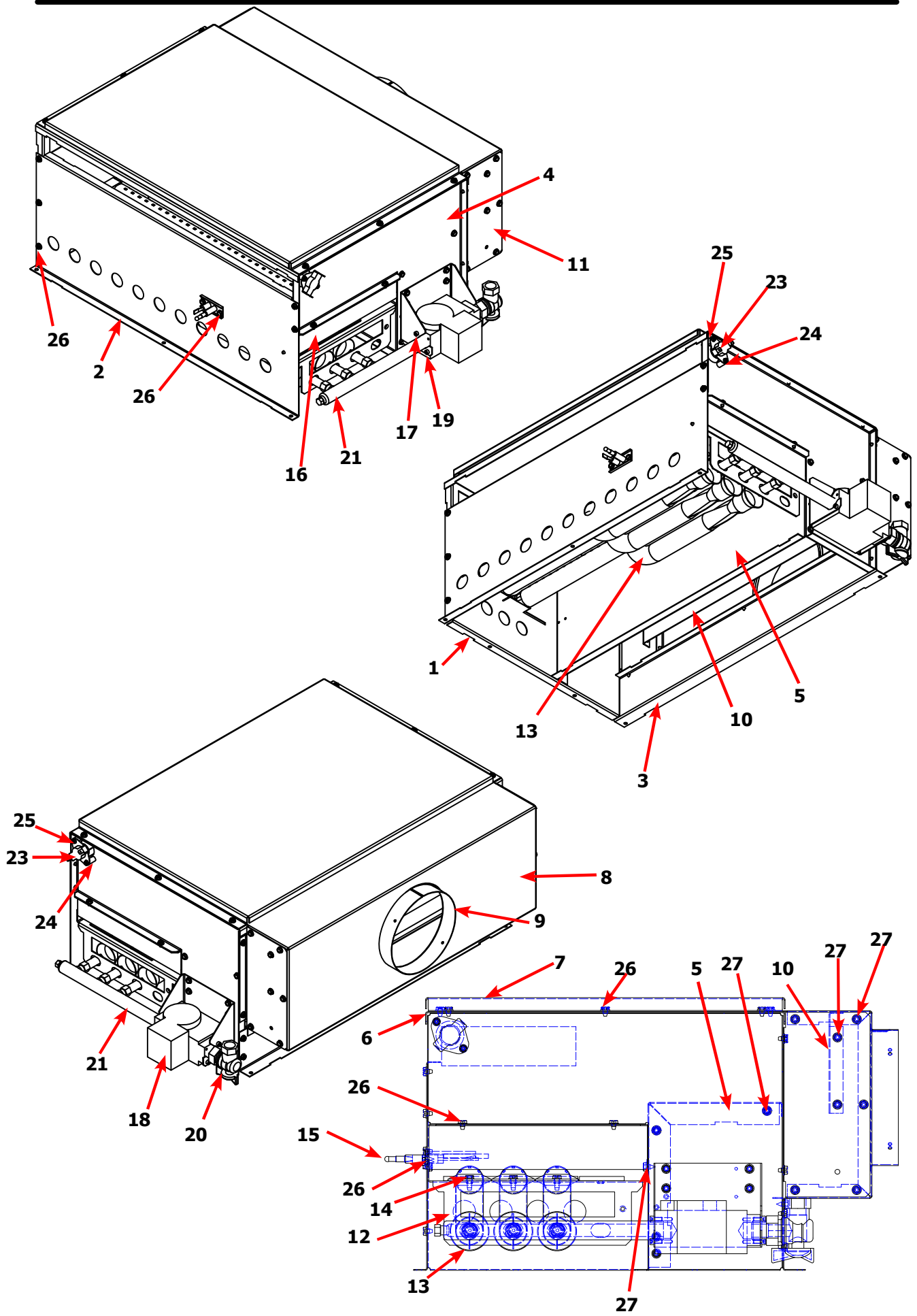

Dryer Burner Housing Group 80Lb

Key	Description	Part Number	Qty
	Housing Assembly, Burner	9803-212-001	1
1	Panel-Burner Housing, Front	9454-863-001	1
2	Panel-Burner Housing, Side Right	9454-861-001	1
3	Panel-Burner Housing, Side Left	9454-862-001	1
4	Panel-Burner Housing, Back	9454-864-001	1
5	Baffle-Burner Housing, Center	9049-098-001	1
6	Panel-Burner Housing, Top	9454-849-001	1
7	Panel-Burner Housing, Top	9074-343-001	1
8	Baffle-Burner Housing, Extention	9049-100-001	1
9	Duct Adaptor, 6"x1.25" long	9109-120-002	1
10	Baffle-Burner Housing, Recirculation	9049-099-001	1
11	Side-Extention Baffle, Burner Housing	9551-049-001	2
12	Bracket-Support, Burner	9029-213-001	1
13	Burner, Main	9048-021-001	4
14	Screw, 10T-32x1/2	9545-008-008	4
15	Electrode-Ignition	9875-002-003	1
16	Cover-Burner, Intet	9074-344-001	1
17	Bracket-Support, Gas Valve	9029-234-001	1
18	Control Assy,Gas Valve, White Rodgers 36J	9857-193-001	1
19	Bracket-support, Gas Valve Left hand	9029-235-001	4
20	Valve-Gas Shutoff, (Optional)	9379-196-001	1
21	Manifold Assy	9381-014-001	1
22	Orfice-Natural, #29	9425-069-021	3
*	Orfice-LP, #46	9425-069-022	3
*	Kit, LP Conversion, White Rodgers	9732-102-023	1
23	Thermostat-HI-Limit	9576-203-002	1
24	Spacer-1/4x5/8 long	9538-166-009	2
25	Screw-8Bx1	9545-045-013	2
26	Screw, 10Bx1/4	9545-008-001	22
27	Screw, 10ABx3/8	9545-008-024	31
28	Bushing-Reducer, 3/4x1/2	8615-104-009	1

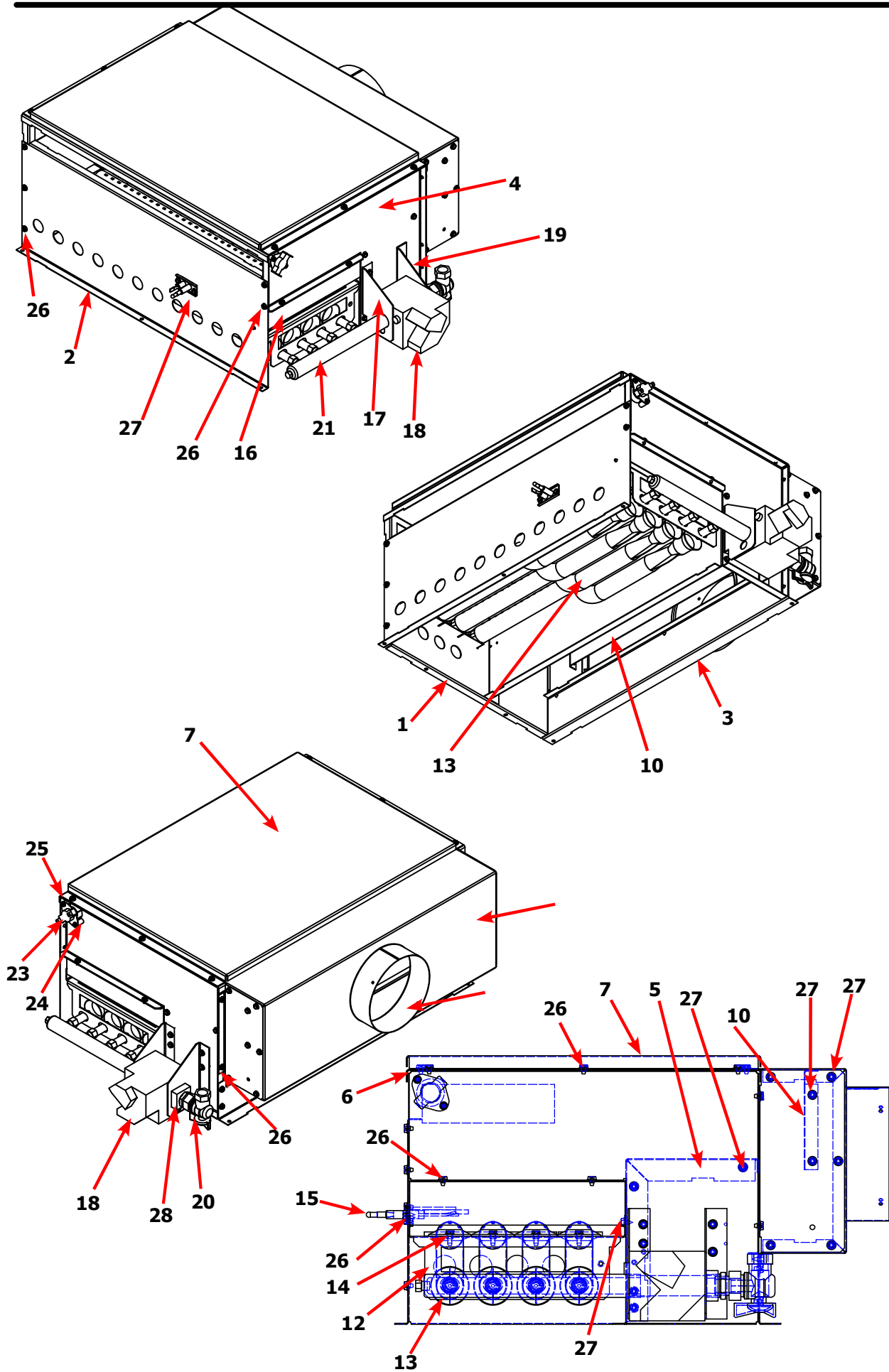

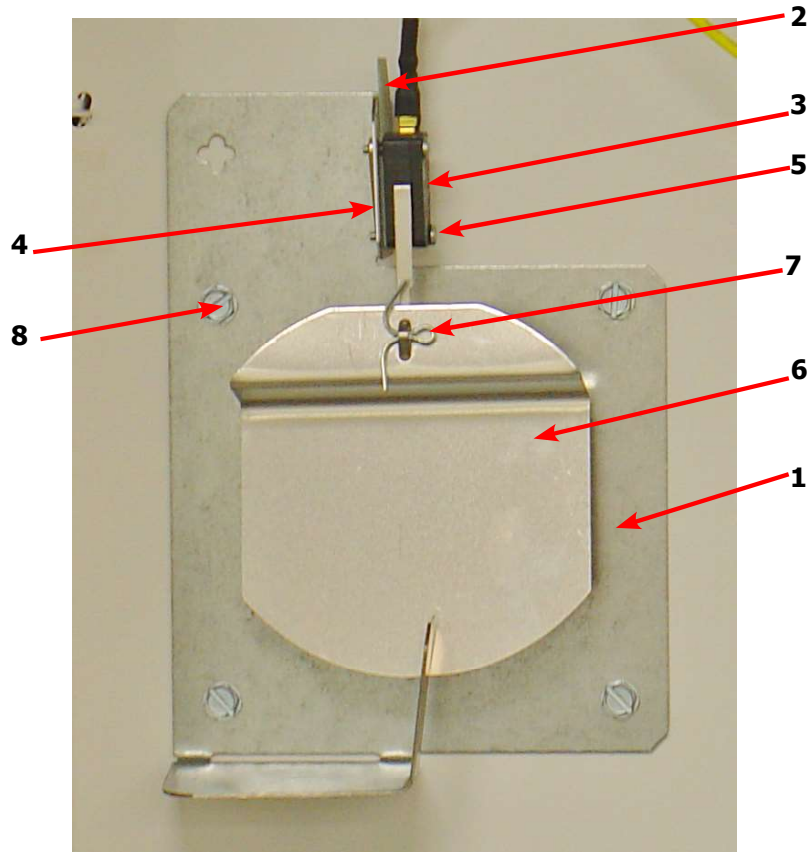

Key	Description	T-30	T-50	T80	QTY
*	Air Flow switch Assy	9801-095-001	9801-098-001	9801-098-001	1
1	Bracket-Airflow switch	9029-174-001	9029-200-001	9029-200-001	1
2	Shield-Switch	9550-169-003	9550-169-003	9550-169-003	1
3	Switch-Micro	9539-461-009	9539-461-009	9539-461-009	1
4	Nut-Twin, 4-40	8640-401-001	8640-401-001	8640-401-001	1
5	Screw-.625, 4-40	9545-020-001	9545-020-001	9545-020-001	2
6	Actuator-Air Flow Switch	9008-007-001	9008-007-001	9008-007-001	1
7	Pin-Cotter, .09375x.75	9451-169-002	9451-169-002	9451-169-002	1
8	Screw, 10Bx1/4	9545-008-001			4
8	Screw, 10Bx1/4		9545-008-001	9545-008-001	5

Electrical Box / Ignition Control

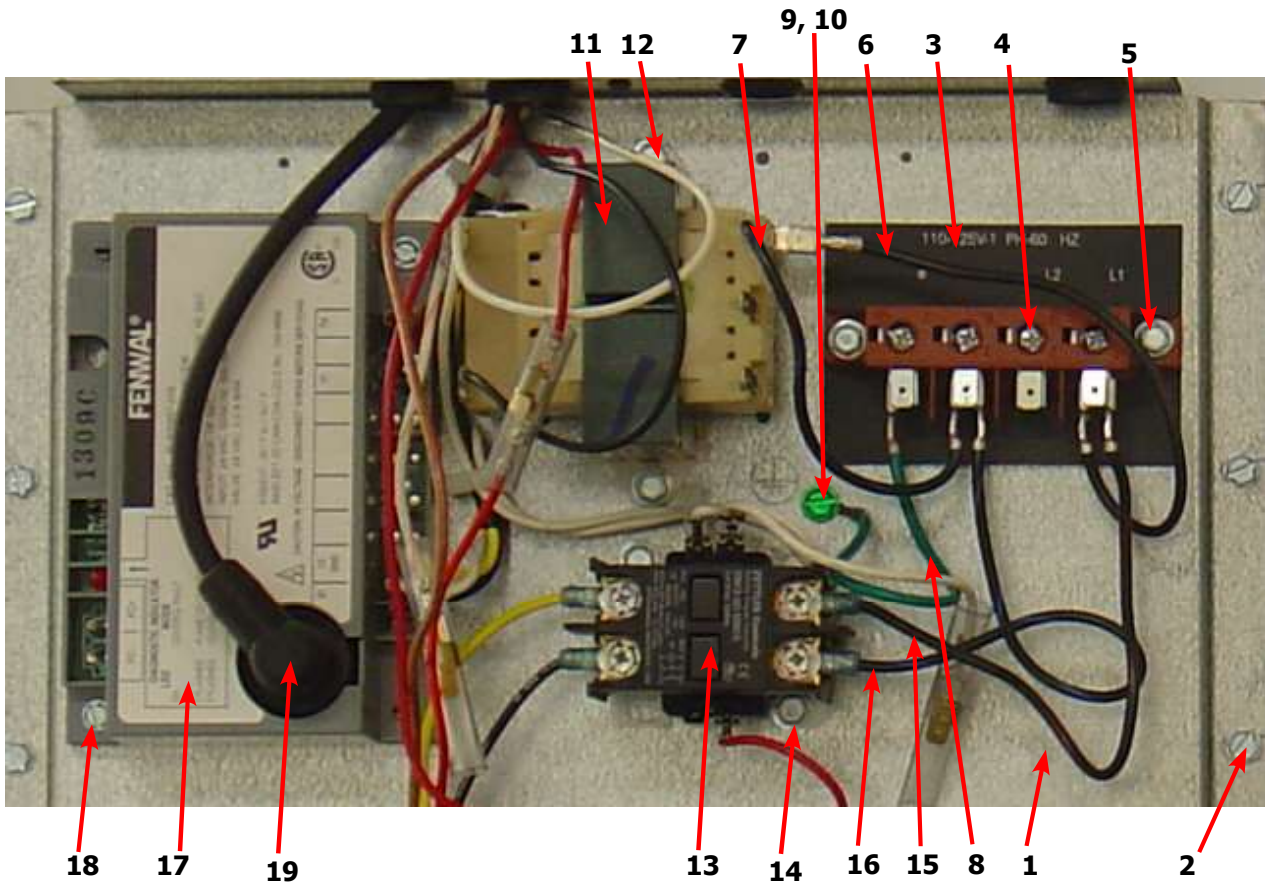

Key	Description	T-30	T-50	T80	QTY
1	Wrapper-Control Box	9636-200-001	9636-200-001	9636-200-001	1
2	Screw, 5/16-10AB-3/8	9545-008-001	9545-008-001	9545-008-001	6
*	Cover-Control Box	9074-346-001	9074-346-001	9074-346-001	1
*	Screw, 5/16-10AB-3/8	9545-008-024	9545-008-024	9545-008-024	1
3	Strip-Marker, Terminal	9558-029-005	9558-029-005	9558-029-005	1
4	Terminal Block Assy-Power, 4Pole	9897-035-001	9897-035-001	9897-035-001	1
5	Screw, 5/16-10AB-3/8	9545-008-024	9545-008-024	9545-008-024	2
6	Wire assy-Blk/Red, 6 1/2"	8220-001-230	8220-001-230	8220-001-230	1
7	Wire assy-Blk/Blu, 6 1/2"	8220-001-231	8220-001-231	8220-001-231	1
8	Wire Assy, GRN, 7"	8220-001-478	8220-001-478	8220-001-478	1
9	Screw- 10-32TTx1/2 GRN	9545-008-027	9545-008-027	9545-008-027	1
10	Lockwasher, External tooth	8641-582-006	8641-582-006	8641-582-006	1
11	Transformer, w/Circuit braker	8711-007-002	8711-007-002	8711-007-002	1
12	Screw, 5/16-10AB-3/8	9545-008-024	9545-008-024	9545-008-024	2
13	Relay-Motor, 30Amp, 24VAC	5192-299-002	5192-299-002	5192-299-002	1
14	Screw, 5/16-10AB-3/8	9545-008-024	9545-008-024	9545-008-024	2
15	Wire assy-Blk/Red, 9"	8220-146-001	8220-146-001	8220-146-001	1
16	Wire assy-Blk/Blu, 9"	8220-146-002	8220-146-002	8220-146-002	1
17	Control Assy, Ignition (Module)	9857-182-001	9857-182-001	9857-182-001	1
18	Screw-8Bx3/4"	9545-045-007	9545-045-007	9545-045-007	2
*	Harness, Ignition Module	9627-867-003	9627-867-003	9627-867-003	1
19	Wire Assy- High Voltage Lead	9631-403-009	9631-403-009	9631-403-009	1

Wiring Informative for 60hz Dryer - 10

INFORMATIVE 6102-018-158PR

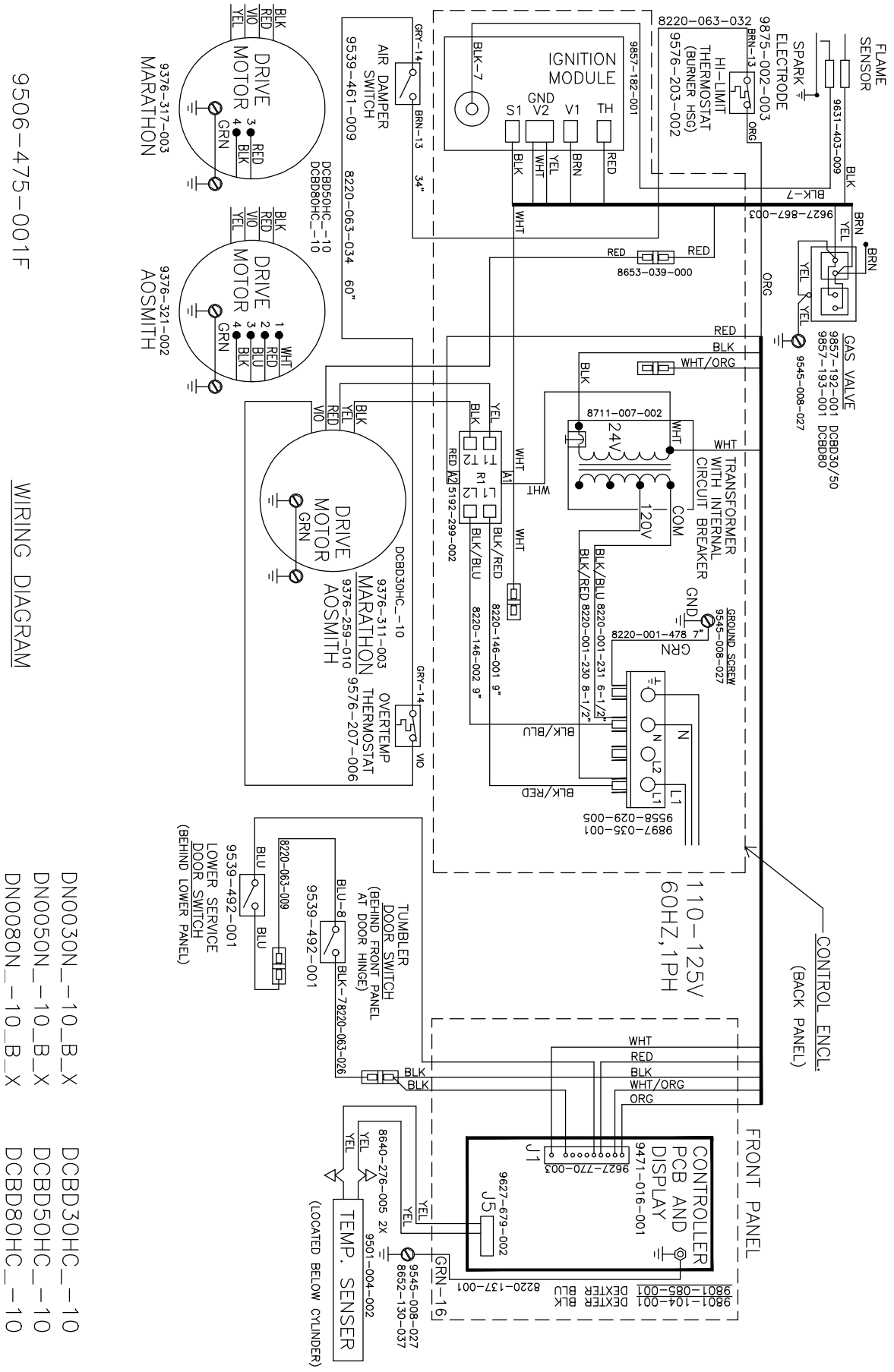

9506-475-001F

WIRING DIAGRAM

- DN0030N_-10_B_X
- DN0050N_-10_B_X
- DN0080N_-10_B_X
- DCBD30HC_-10
- DCBD50HC_-10
- DCBD80HC_-10

Section 6:

Electric Heated Dryer Parts Data

DN0030, 50EC_-74EB, 240V/3 Phase/60HZ 24KW

Key	Description	T-30	T-50	T80	QTY
	Power-Block, 3 Pole	9897-037-001	9897-037-001		1
	Power-Block, 1 Pole	9897-038-001	9897-038-001		1
	Terminal-Lug, Solderless	8652-134-002	8652-134-002		1
	Scrw-10-32TT x1/2 GRN	9545-008-027	9545-008-027		1
	Wire Assy-BLK #13 8"	8220-057-016	8220-057-016		3
	Wire Assy-BLK/RED, 12"	8220-151-001	8220-151-001		1
	Wire Assy-BLK/BLU, #12, 12"	8220-151-002	8220-151-002		1
	Wire Assy-BLK, #35, 9"	8220-078-008	8220-078-008		2
	Wire Assy, WHT, 8"	8220-057-019	8220-057-019		1
	Wire Assy-BLK/RED, #9, 9"	8220-146-001	8220-146-001		1
	Wire Assy-BLK/BLU, #21, 9"	8220-146-002	8220-146-002		1
	Transformer 120/24VAC	8711-007-002	8711-007-002		1
	Relay, R1-Motor Run	5192-299-002	5192-299-002		1
	Wire Assy-WHT, #10, 8"	8220-063-018	8220-063-018		1
	Relay, R2-Heat relay	5192-285-004	5192-285-004		1
	Varistor-Coil Suppressor	9733-003-001	9733-003-001		1
	Relay, Elements	5192-296-001	5192-296-001		1
	Wire Assy-BLK, #33, 8"	8220-057-015	8220-057-015		6
	Curcit Breaker, 3-Pole, 35AMP	5198-213-001	5198-213-001		2
	Wire Assy-BLK, #34, 36"	8220-061-008	8220-061-008		1
	Wire Assy-BLK, #34, 48"	8220-061-010	8220-061-010		1
	Heating Elements, 12KW, 208V	9870-096-006	9870-096-006		2
	Jumper-Formed	9295-004-001	9295-004-001		2
	Jumper-Formed	9295-005-001	9295-005-001		4

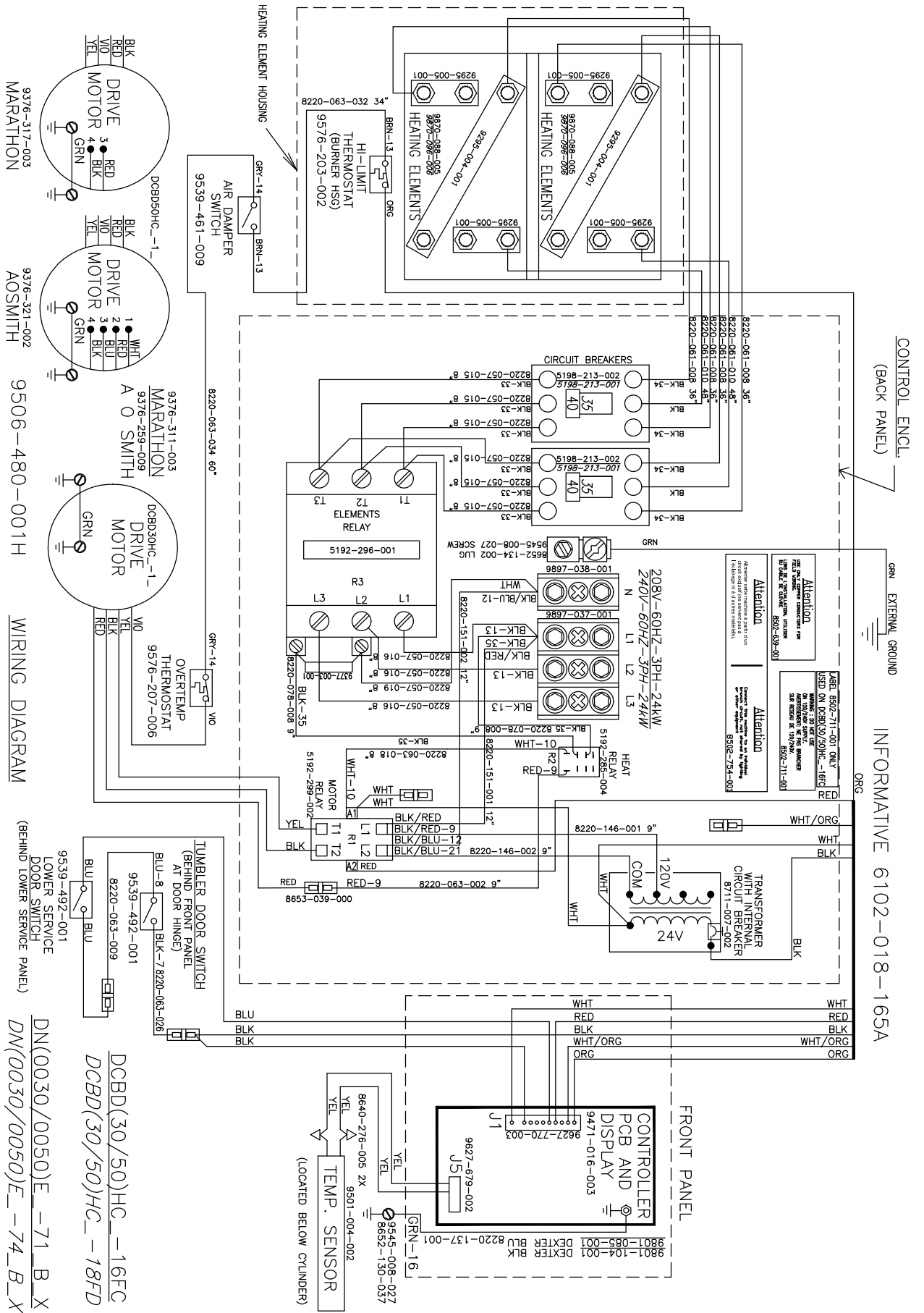

DN0050,80EC_-72EB, 208V/3 Phase/60HZ 30KW

Key	Description	T-30	T-50	T80	QTY
	Power-Block, 3 Pole		9897-037-001	9897-037-001	1
	Power-Block, 1 Pole		9897-038-001	9897-038-001	1
	Terminal marker		9558-032-001	9558-032-001	1
	Terminal-Lug, Solderless		8652-134-002	8652-134-002	1
	Screw-10-32TT x1/2 GRN		9545-008-027	9545-008-027	1
	Wire Assy-BLK 9"		8220-078-008	8220-078-008	1
	Wire Assy-BLK 8"		8220-057-014	8220-057-014	3
	Wire Assy-WHT 8"		8220-057-019	8220-057-019	
	Transformer 250/24VAC		8711-007-002	8711-007-002	1
	Wire Assy-BLK/RED, 12"		8220-151-001	8220-151-001	1
	Wire Assy-BLK/BLU, #12, 12"		8220-151-002	8220-151-002	1
	Wire Assy-BLK/RED, 9"		8220-146-001	8220-146-001	1
	Wire Assy-BLK/BLU, 9"		8220-146-002	8220-146-002	1
	Relay, R1-Motor Run		5192-299-002	5192-299-002	1
	Wire Assy-WHT, 10"		8220-063-018	8220-063-018	1
	Relay, R2-Heat relay		5192-285-004	5192-285-004	1
	Wire Assy-BLK, 9"		8220-078-008	8220-078-008	1
	Varistor-Coil Suppressor		9733-003-001	9733-003-001	1
	Relay, Elements		5192-294-001	5192-294-001	1
	Wire Assy-BLK, #33, 8"		8220-057-015	8220-057-015	6
	Curcit Breaker, 3-Pole, 25AMP		5198-213-004	5198-213-004	2
	Wire Assy-BLK, #34, 36"		8220-061-008	8220-061-008	6
	Wire Assy-BLK, #34, 48"		8220-061-010	8220-061-010	2
	Heating Elements, 17.3KW, 208V		9870-088-001	9870-088-001	2
	Jumper-Formed		9295-005-001	9295-005-001	4
	Jumper-Formed		9295-004-001	9295-004-001	2

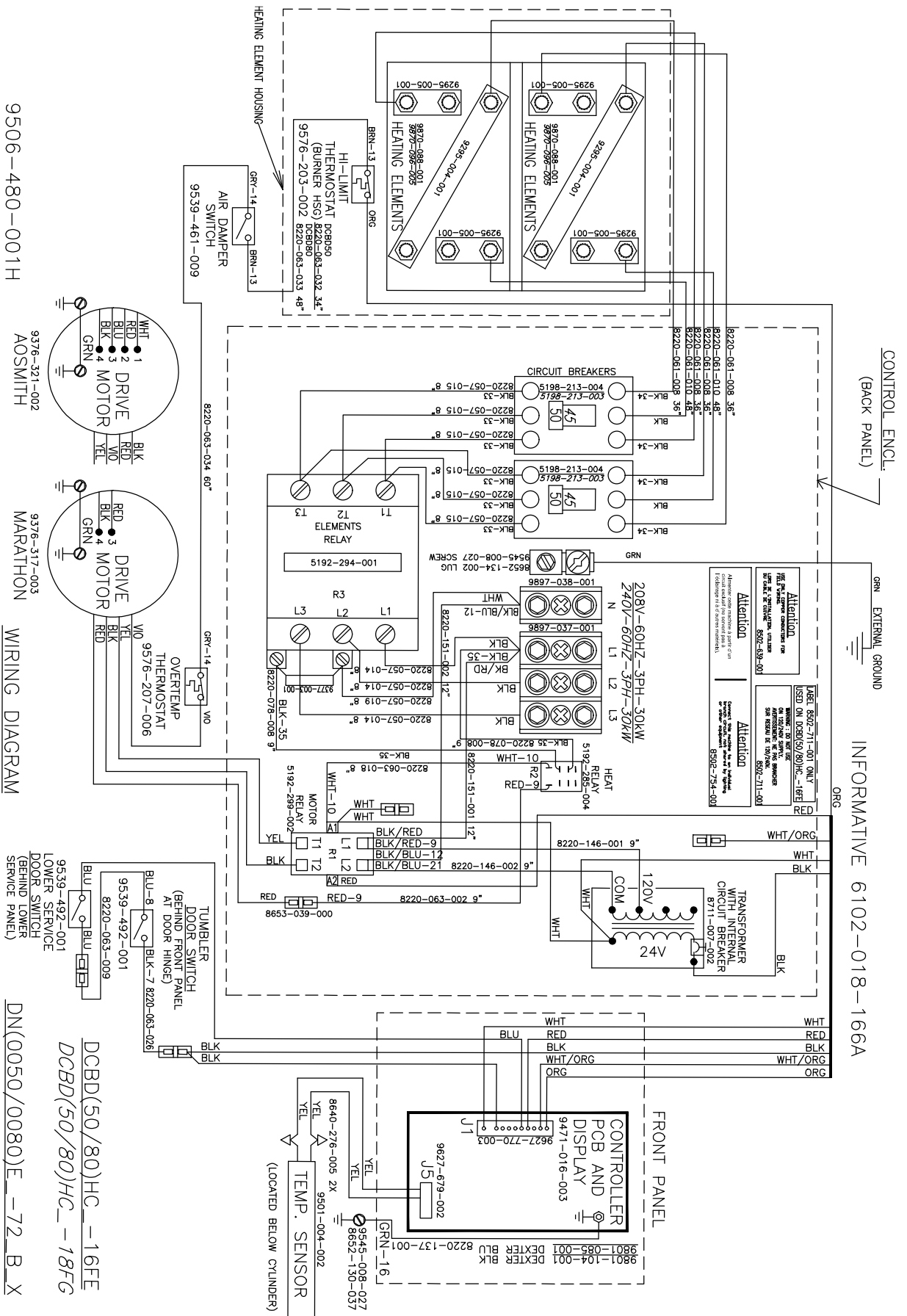

9506-480-001H

9376-321-002
AOSMITH

9376-317-003
MARATHON

WIRING DIAGRAM

9539-492-001
LOWER SERVICE DOOR SWITCH (BEHIND LOWER SERVICE PANEL)

9539-492-001
DCBD(50/80)HC-16FE
DCBD(50/80)HC-18FG

DN(0050/0080)E-72_B_X
DN(0050/0080)E-75_B_X

DN0080EC_-73EB, 208V/3 Phase/60HZ 34.6KW

Key	Description	T-30	T-50	T80	QTY
	Power-Block, 3 Pole			9897-037-001	1
	Power-Block, 1 Pole			9897-038-001	1
	Terminal marker			? 9558-032-001	1
	Terminal-Lug, Solderless			8652-134-002	1
	Screw-10-32TT x1/2 GRN			9545-008-027	1
	Wire Assy-BLK 9"			8220-078-008	1
	Wire Assy-BLU #2, 11"			8220-064-061	1
	Wire Assy-BLK 8"			8220-057-017	3
	Wire Assy-WHT 8"			8220-057-019	
	Transformer 250/24VAC			8711-008-002	1
	Wire Assy-BLK/RED, 12"			8220-151-001	1
	Wire Assy-BLK/BLU, #12, 12"			8220-151-002	1
	Wire Assy-BLK/RED, 9"			8220-146-001	1
	Wire Assy-BLK/BLU, 9"			8220-146-002	1
	Relay, R1-Motor Run			5192-299-002	1
	Wire Assy-WHT, 10"			8220-063-018	1
	Relay, R2-Heat relay			5192-285-004	1
	Wire Assy-BLK, 9"			8220-078-008	1
	Varistor-Coil Suppressor			9733-003-001	1
	Relay, Elements			5192-294-001	1
	Wire Assy-BLK, #33, 8"			8220-057-015	6
	Curcit Breaker, 3-Pole, 25AMP			5198-213-005	2
	Wire Assy-BLK, #34, 36"			8220-061-008	6
	Wire Assy-BLK, #34, 48"			8220-061-010	2
	Heating Elements, 17.3KW, 208V			9870-088-006	2
	Jumper-Formed			9295-005-001	4
	Jumper-Formed			9295-004-001	2

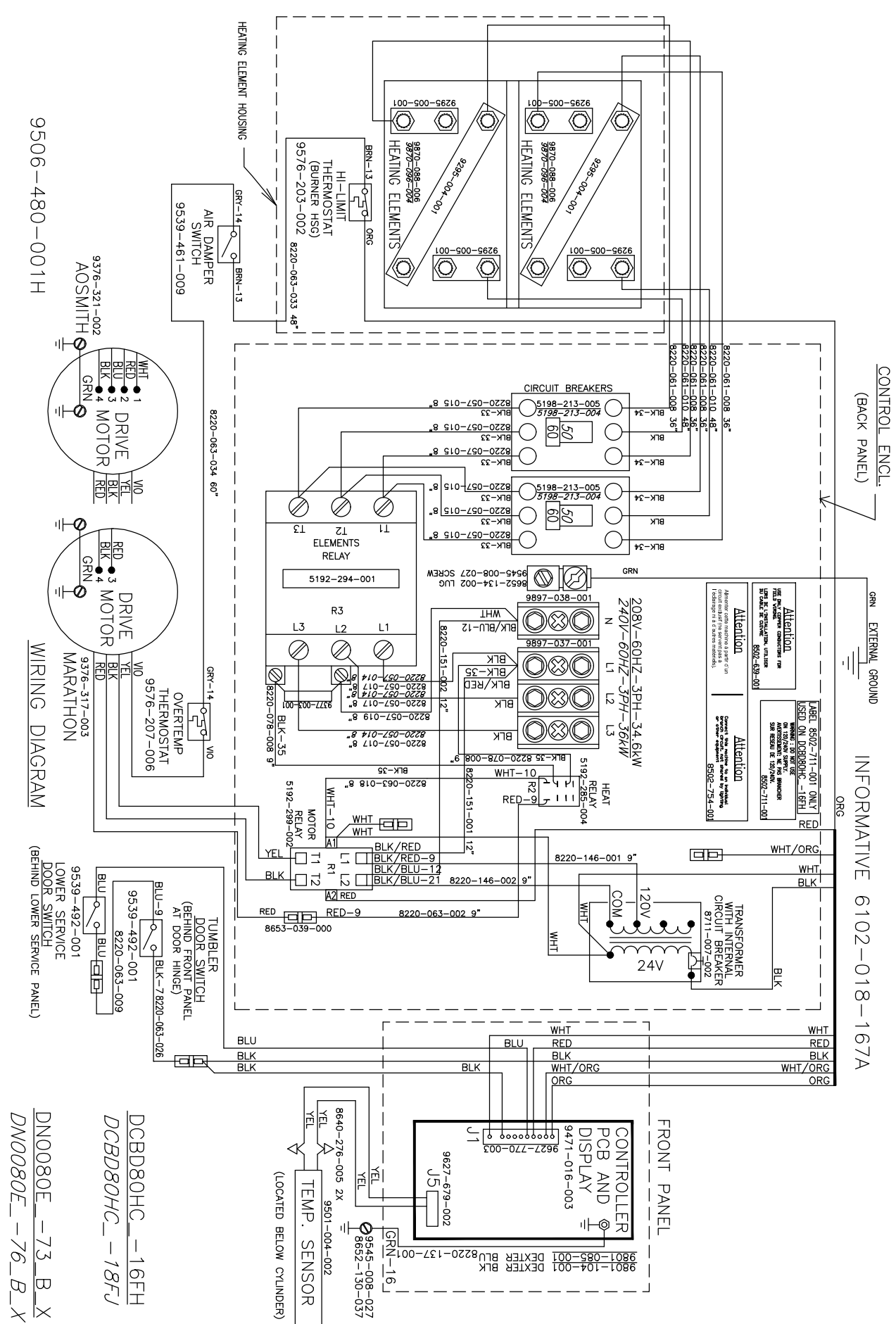

9506-480-001H

WIRING DIAGRAM

(BEHIND LOWER SERVICE PANEL)

DN0080E_73_B_X
 DN0080E_76_B_X

DCBD80HC_16FH
 DCBD80HC_18FU

Section 7:

50Hz

Dryer Parts Data

DN0030.50.80NC_-39 230VAC 1 PH 50Hz

Key	Description	T-30	T-50	T80	QTY
	Motor	9376-311-004	9376-317-004	9376-317-004	1
	Pulley	9453-169-009	9435-169-014	9453-169-009	1
	Strip Terminal Marker	9558-029-004	9558-029-004	9558-029-004	1
	Wiring Label-Schematic/Diagram	9506-496-001	9506-496-001	9506-496-001	1
	Switch Assembly-Air flow	9801-095-002			
	Bracket-Airflow switch	9029-174-002			
	Switch Micro	9539-461-009			
	Orfice Main Burner, #32	9425-069-009			2
	Orfice Main Burner, #32		9425-069-009		3
	Orfice Main Burner, #30			9425-069-002	4
	LP Kit	9732-102-019	9732-102-021	9732-102-022	1
	Overlay-Trim Lower door	9435-016-004	9435-016-005	9435-016-005	1

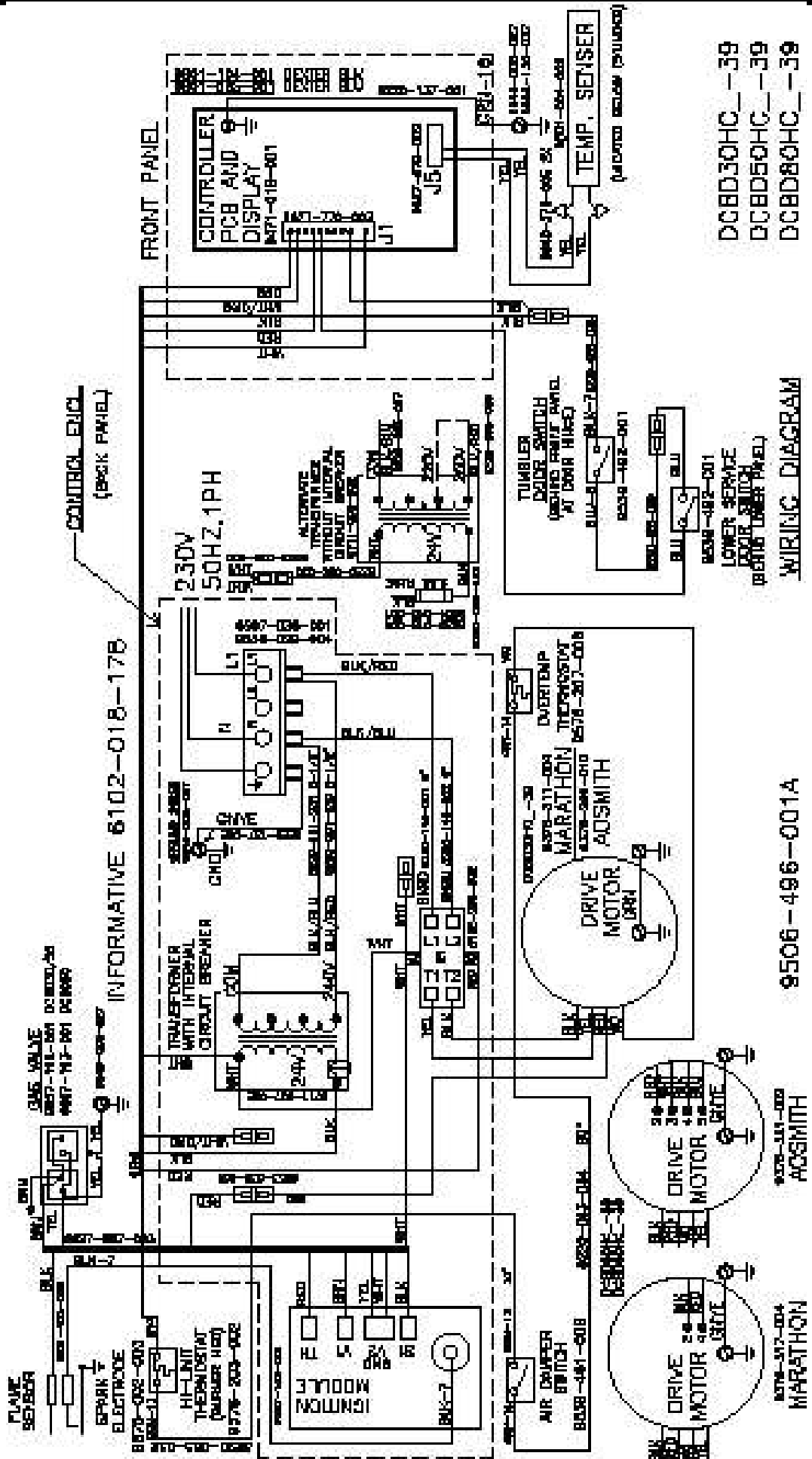

INFORMATIVE 6102-018-17B

DCBD30HC_ -39
 DCBD50HC_ -39
 DCBD80HC_ -39

WIRING DIAGRAM

9506-496-001A

