



DN0030ND-15EO
DN0050ND-15EO
DN0080ND-15EO

Section 5:

Dryer Parts

Data

Dryer Cabinet Group

Key	Description	T-30	T-50	T-80	QTY
1	Loading Door Complete SS/Brushed SS/Blk	9960-306-001	9960-305-001	9960-305-001	1
1	Loading Door Complete Wht/Brushed SS/Blk	9960-306-003	9960-305-003	9960-305-003	1
2	Door Assy, Loading (Ring only) Brushed SS	9960-255-008	9960-284-002	9960-284-002	1
3	Plate Assy, Hinge (SS)	9982-374-001	9982-368-001	9982-368-001	1
3	Plate Assy, Hinge (Wht)	9982-374-003	9982-368-003	9982-368-003	1
*	Cover-Hinge Back, Black	9074-341-002	9074-340-002	9074-340-002	1
*	Screw-10Bx3/8, Black	9545-008-010	9545-008-010	9545-008-010	2
*	Screw Hinge to Door	9545-012-015	9545-012-015	9545-012-015	4
*	Nut, Hinge to Door	8640-413-002	8640-413-002	8640-413-002	4
4	Glass, Door	9212-002-003	9212-002-004	9212-002-004	1
5	Gasket, Door Glass (Black)	9206-413-001	9206-413-002	9206-413-002	1
*	Support Door Glass	9548-117-000	9548-117-000	9548-117-000	2
6	Gasket, Door Outer Rim (Black)	9206-420-003	9206-420-005	9206-420-005	1
7	Handle, Loading Door	9244-093-001	9244-093-001	9244-093-001	1
*	Screw, Handle	9545-018-017	9545-018-017	9545-018-017	2
8	Stud Door Catch	9531-033-002	9531-033-002	9531-033-002	1
9	Nut-Hex, #10-32	8640-413-001	8640-413-001	8640-413-001	1
10	Nut, Acorn	8640-413-003	8640-413-003	8640-413-003	1
*	Catch, Loading Door	9086-015-002	9086-015-002	9086-015-002	2
*	Rivit	9244-093-001	9244-093-001	9244-093-001	4
11	Strap, Hinge (Black)	9966-018-002	9966-014-002	9966-014-002	1
*	Plate Assy-Backup, Hinge	9982-386-001	9982-356-001		2
*	Plate Assy-Backup, Hinge			9982-369-001	1
*	Reinforcement-Front panel			9817-003-001	1
12	Screw-Phillips, 10-32x1/2 Chrome	9545-012-003	9545-012-003	9545-012-003	8
*	Screw-Phillips-Counter sink, 10-32x1/2 Chrome	9545-012-028	9545-012-028	9545-012-028	4
13	Screw-Special, Hinge to Door	9545-052-001	9545-052-001	9545-052-001	1
*	Nut-Allen, 1/4-20	8640-439-001	8640-439-001	8640-439-001	1
14	Washer-Fiber/Plastic	8641-436-003	8641-436-003	8641-436-003	1
15	Front Panel Assy (Wht)	9989-623-008	9989-624-008	9989-625-008	1
15	Front Panel Assy (ss)	9989-623-007	9989-624-007	9989-625-007	1
16	Screw-Phillips, 10Bx1 3/4	9545-008-014	9545-008-014	9545-008-014	4
17	Washer-Finish	8641-585-001	8641-565-001	8641-585-001	4
*	Nut-Spring	8640-399-001	8640-399-001	8640-399-001	4
*	Insulation-Front Panel, Top Half	9277-063-001	9277-057-001	9277-058-001	1
*	Insulation-Front Panel, Bottom Half	9277-063-002	9277-057-002	9277-058-002	1
18	Label-Warning	8502-758-001	8502-758-001	8502-758-001	1
19	Plug-Front Panel	9456-050-001	9456-055-001	9456-050-001	1
*	Switch-Door Closed	9539-492-001	9539-501-001	9539-492-001	1
*	Wiringharness-door Switch	9627-918-001	9627-948-001	9627-918-001	1
*	Wire-Assy-Blu	8220-063-009	8220-063-009	8220-063-009	1

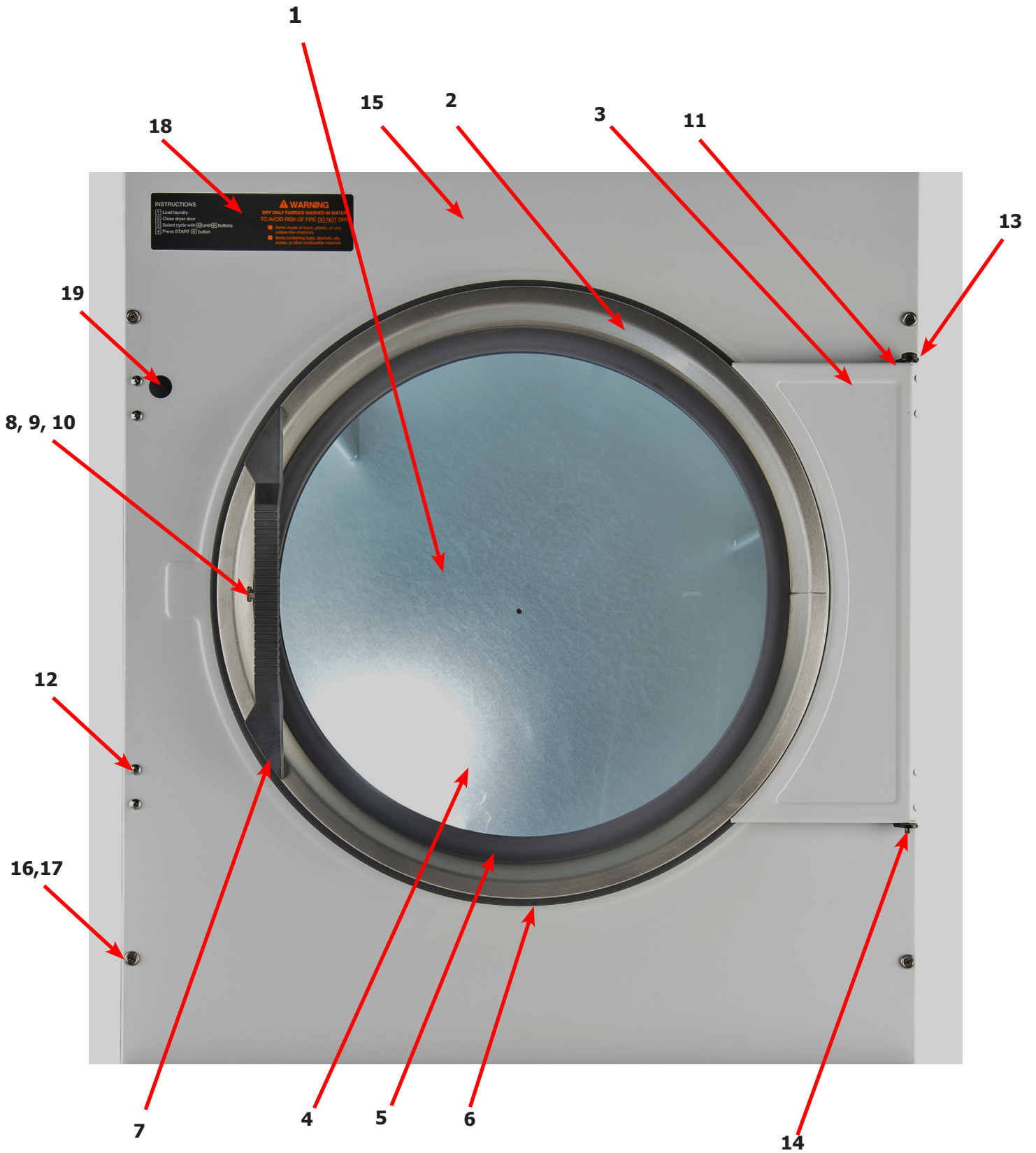

Dryer Cabinet Group Continued

Key	Description	T-30	T-50	T-80	QTY
1	Nameplate - Dexter Dryer Black	9412-252-001	9412-253-001	9412-254-001	1
2	Door Assy-Upper, OPL (SS)	9960-325-007	9960-326-009	9960-327-009	1
2	Door Assy-Upper, OPL (Wht)	9960-325-008	9960-326-010	9960-327-010	1
3	Bracket-Hinge	9029-224-001	9029-224-001	9029-224-001	2
	Screw-hxwshd,10-32x3/8	9545-012-015	9545-012-015	9545-012-015	2
	Nut-hexkeps,#10-32unf,2b	8640-413-002	8640-413-002	8640-413-002	4
*	Rivit- 3/16, Hinge to Door	9491-009-001	9491-009-001	9491-009-001	2
*	Rivit- 3/16, Hinge to Cabinet	9491-009-001	9491-009-001	9491-009-001	AR
4	Trim-Upper Service Door, Black	9578-098-002	9578-094-002	9578-096-002	1
5	Screw-Phillips, 10Bx3/8, Black	9545-008-010	9545-008-010	9545-008-010	4
6	Screw-Phillips, 10Bx1 3/4	9545-008-014	9545-008-014	9545-008-014	2
7	Washer-Finish	8641-585-001	8641-585-001	8641-585-001	2
*	Nut-Spring	8640-399-001	8640-399-001	8640-399-001	2
8	Support-Upper Service Door	9548-288-001	9548-288-002	9548-288-002	1
*	Clamp-tube	9079-121-002	9079-121-002	9079-121-002	2
*	Nut-hexkeps,#6-32	8640-411-003	8640-411-003	8640-411-003	2
9	Contrlassy-display,2.0,opl,dry	9857-230-002	9857-230-002	9857-230-002	2
*	Button-control,2.0,opl	9035-063-001	9035-063-001	9035-063-001	1
*	Window-display,lcd(w/gasket)	9635-021-002	9635-021-002	9635-021-002	1
*	Nut, #6-32	8640-411-003	8640-411-003	8640-411-003	4
*	Clamp-Cable, 1/2"	9079-121-002	9079-121-002	9079-121-002	2
*	Nut, #6-32	8640-411-003	8640-411-003	8640-411-003	1
10	Insulation	9277-041-016	9277-041-016	9277-041-016	1
11	Harness-Control	9627-922-001	9627-922-001	9627-922-001	1
*	Harness-Temp Probe	9627-917-001	9627-917-001	9627-917-001	1
12	Pcbassy-maincontrol	9799-027-001	9799-027-001	9799-027-001	1
	Screw-hxwshrdundct,#10bx1/2	9545-008-024	9545-008-026	9545-008-024	4
	Wireasy,2.0,t-1200/t-30fss	8220-158-027	8220-158-011	8220-158-017	1
	Wiringharness-power,relay	9627-919-003	9627-919-003	9627-919-003	1
	Cableassy-usb,snapin	9806-024-001	9806-024-001	9806-024-001	1
13	Bracket-mtg,control	9029-301-001	9029-301-001	9029-301-001	1
*	Screw-hxwshrduncutd,10abx3/8	9545-008-024	9545-008-024	9545-008-024	4
*	Bushing-insulated,1"	9053-067-004	9053-067-004	9053-067-004	2

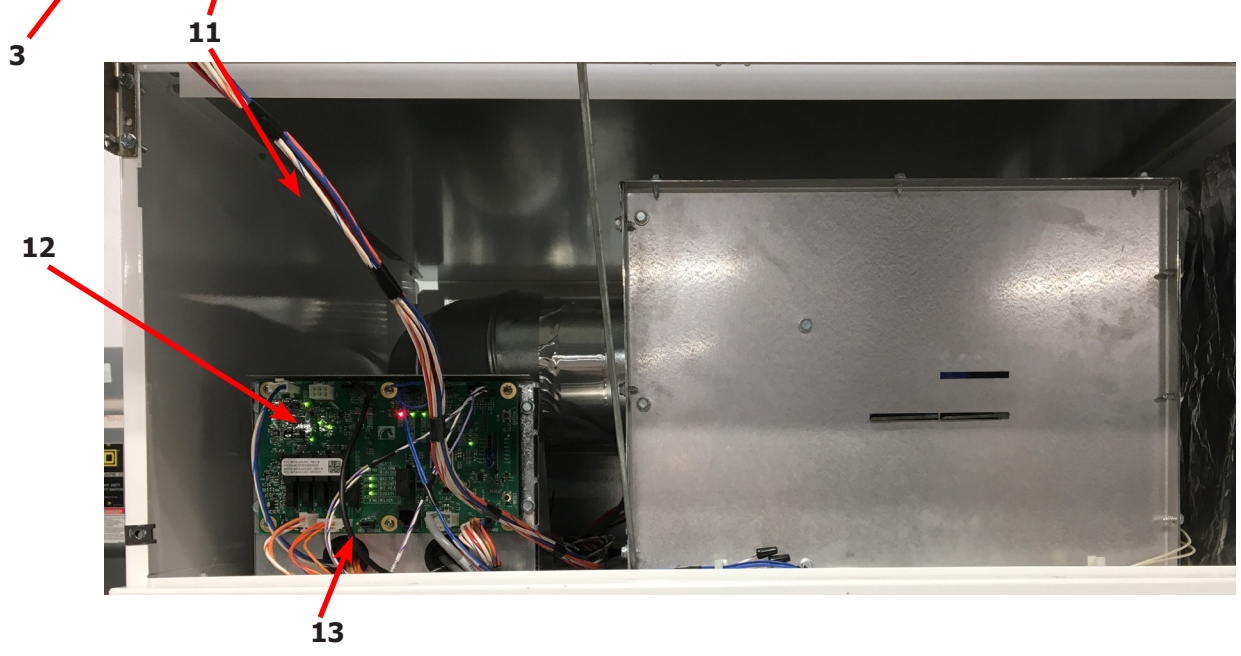
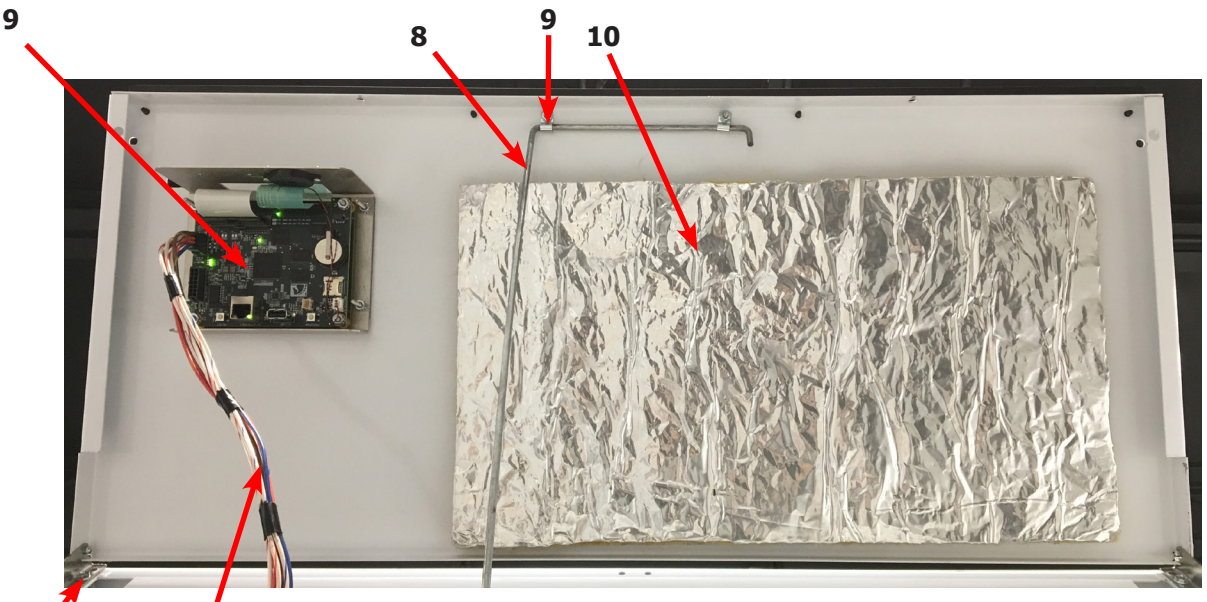
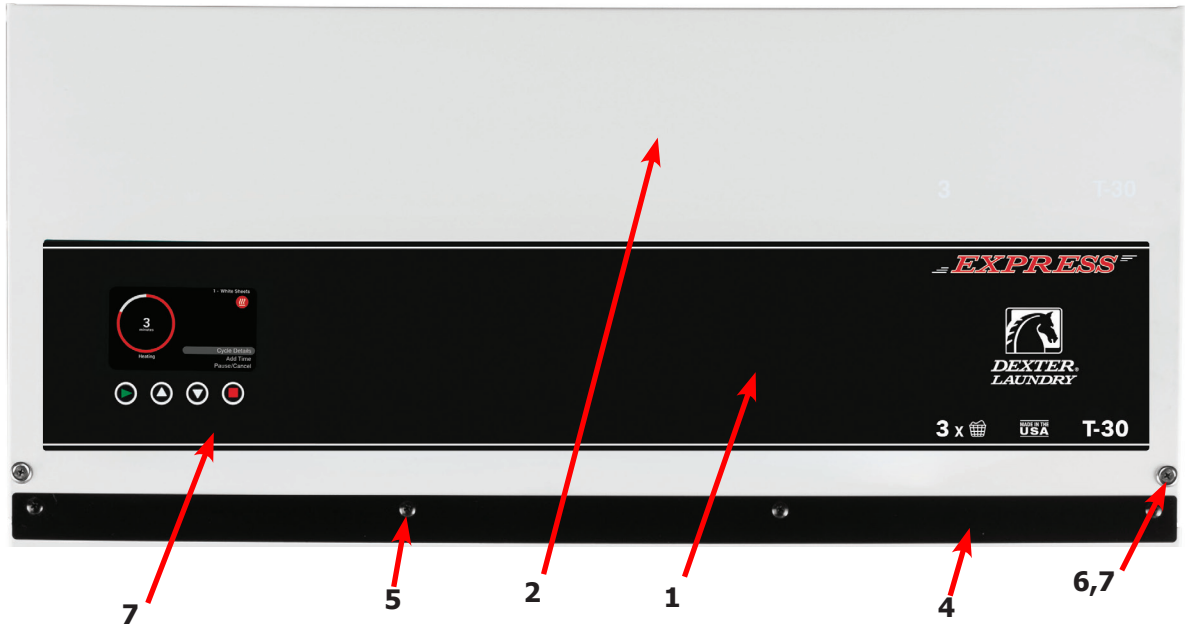

Dryer Cabinet Group Continued

Key	Description	T-30	T-50	T-80	QTY
1	Door-Lower Service, OPL, SS	9960-321-003	9960-322-003	9960-323-003	1
1	Door-Lower Service, OPL, Wht	9960-321-004	9960-322-004	9960-323-004	1
2	Handle-Door, Lower Service, Black	9244-089-002	9244-087-002	9244-088-002	1
3	Screw-Phillips, 10Bx3/8, Black	9545-008-010	9545-008-010	9545-008-010	5
4	Handle-Door, Lower Service OPL	9244-084-002	9244-084-002	9244-084-002	1
5	Trim-Lower Kick, Black	9578-099-002	9578-095-002	9578-097-002	1
6	Screw-Phillips, 10Bx3/8, Black	9545-008-010	9545-008-010	9545-008-010	4
7	Screen Assy, Lint	9822-026-002	9822-026-001	9822-031-002	1
8	Switch-Door Closure (Circular)	9539-492-001	9539-492-001	9539-492-001	2
*	Switch-Door Closure (Square)	9539-501-001	9539-501-001	9539-501-001	2
9	Hinge-Door, Lower	9243-081-001	9243-082-001	9243-082-001	1
10	Screw-5/16, 10ABx3/8	9545-008-024	9545-008-024	9545-008-024	5
11	Bracket-Door Switch	9029-226-001	9029-226-001	9029-226-001	1
*	Rivit, 1/8 Low Profile	9491-009-004	9491-009-004	9491-009-004	2
12	Bracket-Chain	9029-223-001	9029-223-001	9029-223-001	2
*	Rivit, 1/8 Low Profile	9491-009-004	9491-009-004	9491-009-004	8
13	Hook, "S" Type	9248-022-002	9248-022-002	9248-022-002	4
14	Chain-Lower Service Door	9099-012-006	9099-012-006	9099-012-006	2
*	Leg-leveling	8544-006-001	8544-006-001	8544-006-001	4

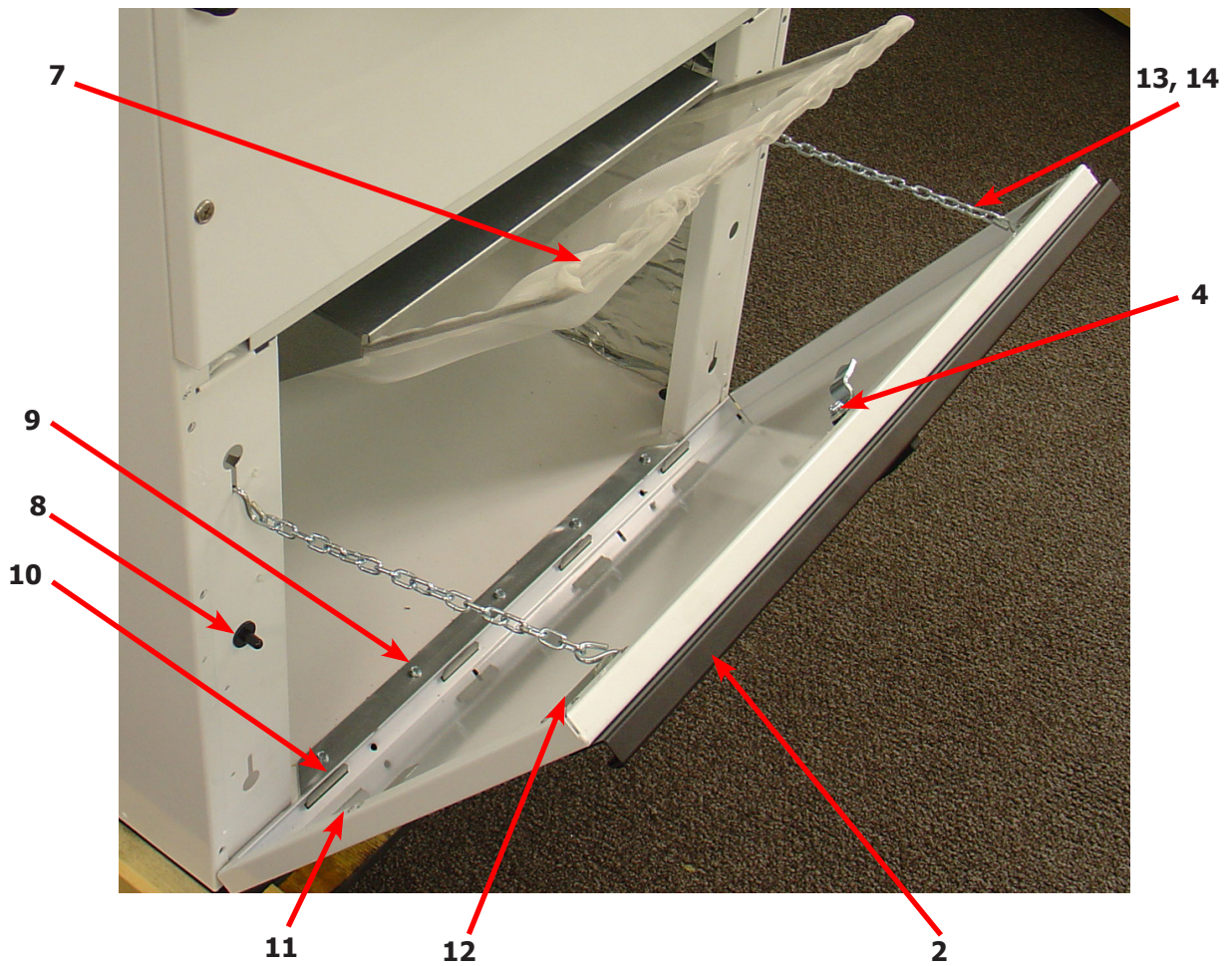
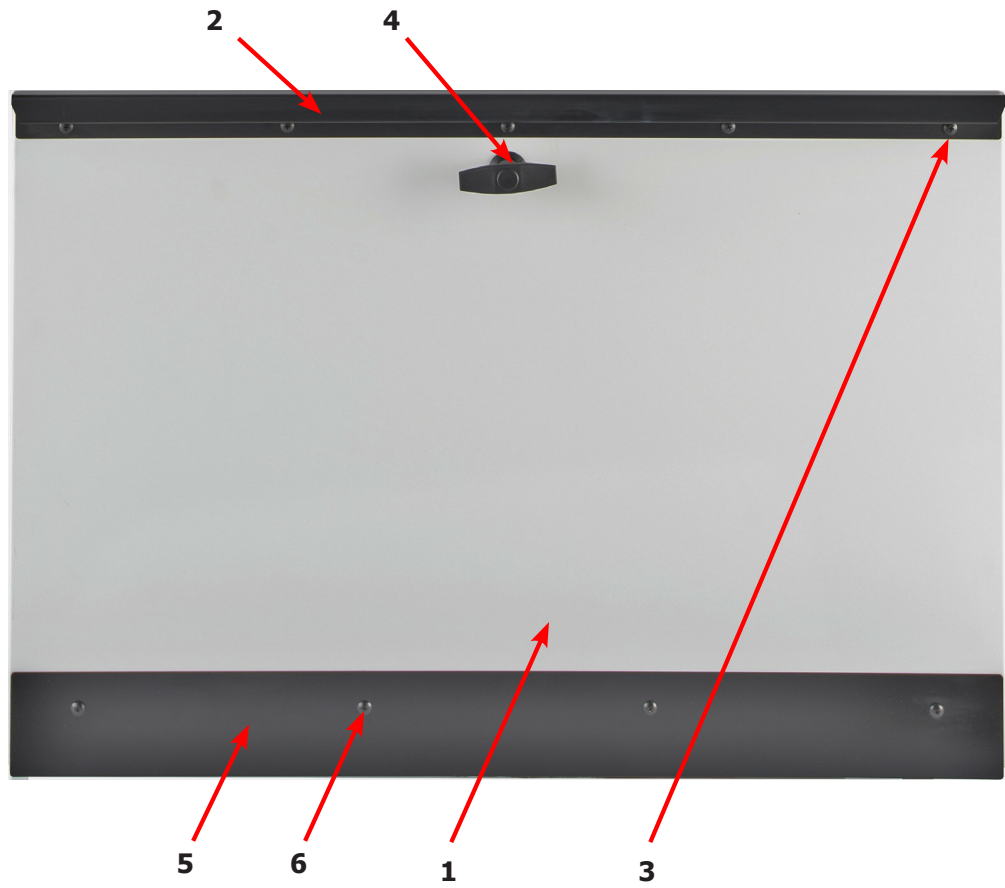

Dryer Cabinet Group Continued

Key	Description	T-30	T-50	T-80	QTY
1	Insulation, Upper service Door	9277-041-016	9277-041-016	9277-041-016	1
2	Insulation, RH Burner	9277-041-019		9277-041-023	1
3	Insulation Tumbler Area, above Baffle	9277-041-020		9277-041-021	2
*	Insulation Tumbler Area, above Baffle			9277-051-004	3
4	Insulation Tumbler Area, below baffle	9277-041-020			2
*	Insulation Tumbler Area, below baffle			9277-051-004	3
5	Insulation Lint Compartment	9277-041-021		9277-041-025	2
*	Screen Assy, Lint	9822-026-002	9822-026-001	9822-031-002	1
6	Switch-Door Closure	9539-492-001	9539-501-001	9539-492-001	AR
7	Hinge-Door, Lower	9243-081-001	9243-082-001	9243-082-001	1
8	Screw-5/16, 10ABx3/8	9545-008-024	9545-008-024	9545-008-024	AR
9	Lint Hood-Back	9240-038-001	9240-041-001	9240-044-001	1
10	Nut Wizlock, 8-32	8640-412-004	8640-412-004	8640-412-004	6
11	Lint hood, LH	9240-040-001	9240-043-001	9240-046-001	1
12	Lint hood, RH	9240-040-002	9240-043-002	9240-046-002	1
13	Lint hood, Top	9240-039-001	9240-042-001	9240-045-001	1
14	Screw, 5/16- 10ABx3/8	9545-008-024	9545-008-024	9545-008-024	14
15	Impeller, w/set screws	9278-043-001	9278-037-003	9278-037-003	1
16	Harness -Temp Probe	9627-917-001	9627-917-001	9627-917-001	1
17	Wire Nut, #71B	8640-276-005	8640-276-005	8640-276-005	2
18	Bracket, Temp Probe	9029-197-001	N/A	N/A	1
19	Screw-5/16, 10ABx3/8	9545-008-024	N/A	N/A	2
20	Temp Probe	9501-004-004	9501-004-004	9501-004-004	1
21	Screw-Phillips, 8Bx1/4	9545-045-005	9545-045-005	9545-045-005	1

30lb Temp Probe

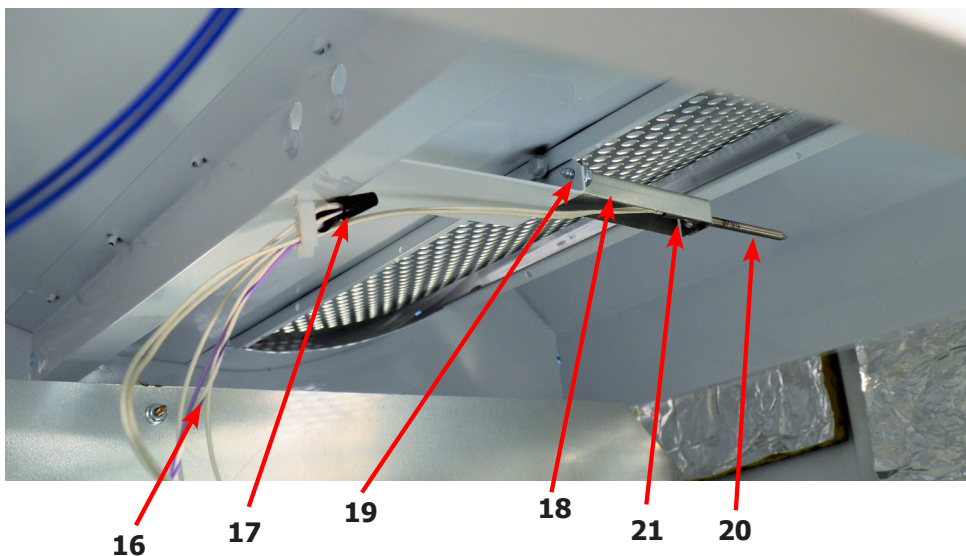

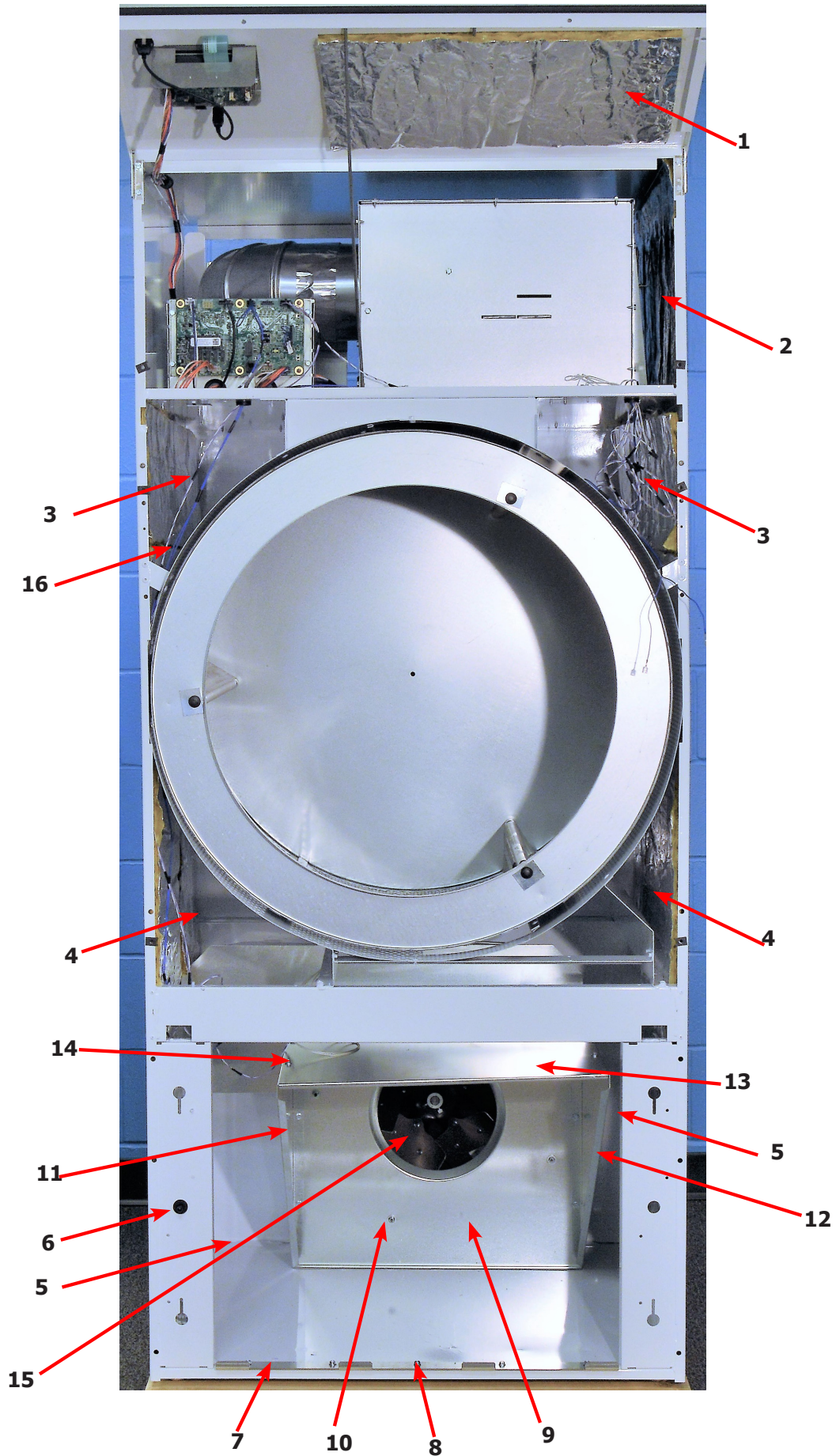

Dryer Rear View 30Lb

Key	Description	T-30	QTY
1	Motor	9376-311-005	1
2	Pulley	9453-157-001	1
*	Set screw	9545-028-013	1
3	Plate, Motor mounting	9982-370-002	1
*	Gasket, Motor Plate	9206-428-002	1
4	Nut-3/8-16, Plate to cabinet	8640-415-004	4
*	Impeller w/set screw	9278-043-001	1
5	Screw, 5/16-18x5/8	9545-014-004	4
6	Nut, 5/16-18	8640-400-003	4
7	Support Arm, Intermediate pulley	9991-053-001	1
8	Bolt- 3/8-16x1 1/4	9545-029-010	3
9	Nut, Wizlock, 3/8x16	8640-415-004	3
*	Cap Screw, 3/8-16x1 1/2	9545-029-003	1
*	Snap Ring	9487-200-003	1
*	Washer-Flat, 3/8x1	8641-581-035	3
10	Idler Arm Assembly	9861-022-001	1
11	Washer-Flat, 3/8x1	8641-581-035	2
12	Pulley, Idler w/Bearings	9908-039-004	1
13	Bearing, Bronze	9036-145-002	2
14	Snap Ring	9487-200-003	1
15	Hook "S" type	9248-022-002	3
16	Chain, Spring tension	9099-012-002	1
17	Spring, tension	9534-319-002	1
18	Chain, Limit	9099-012-007	1
19	Belt Drive	9040-076-003	1
*	Tolerance Ring	9487-234-005	1
20	Pulley, Driven	9908-049-002	1
21	Washer-Flat, 1/2	8641-581-026	1
22	Washer-Lock, Ext. tooth, 1/2	8641-582-016	1
23	Bolt-3/4, 1/2-13x1 1/4	9545-017-009	1
24	Belt, Driven	9040-073-009	1
25	Thermostat-safety reset	9576-207-006	1
*	Screw-hxwshrundrcuthd,10abx3/8	9545-008-024	2

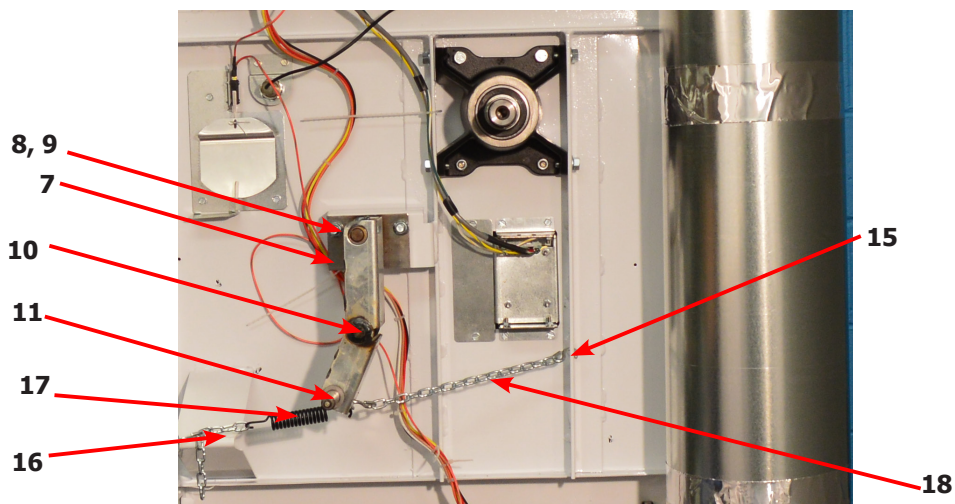

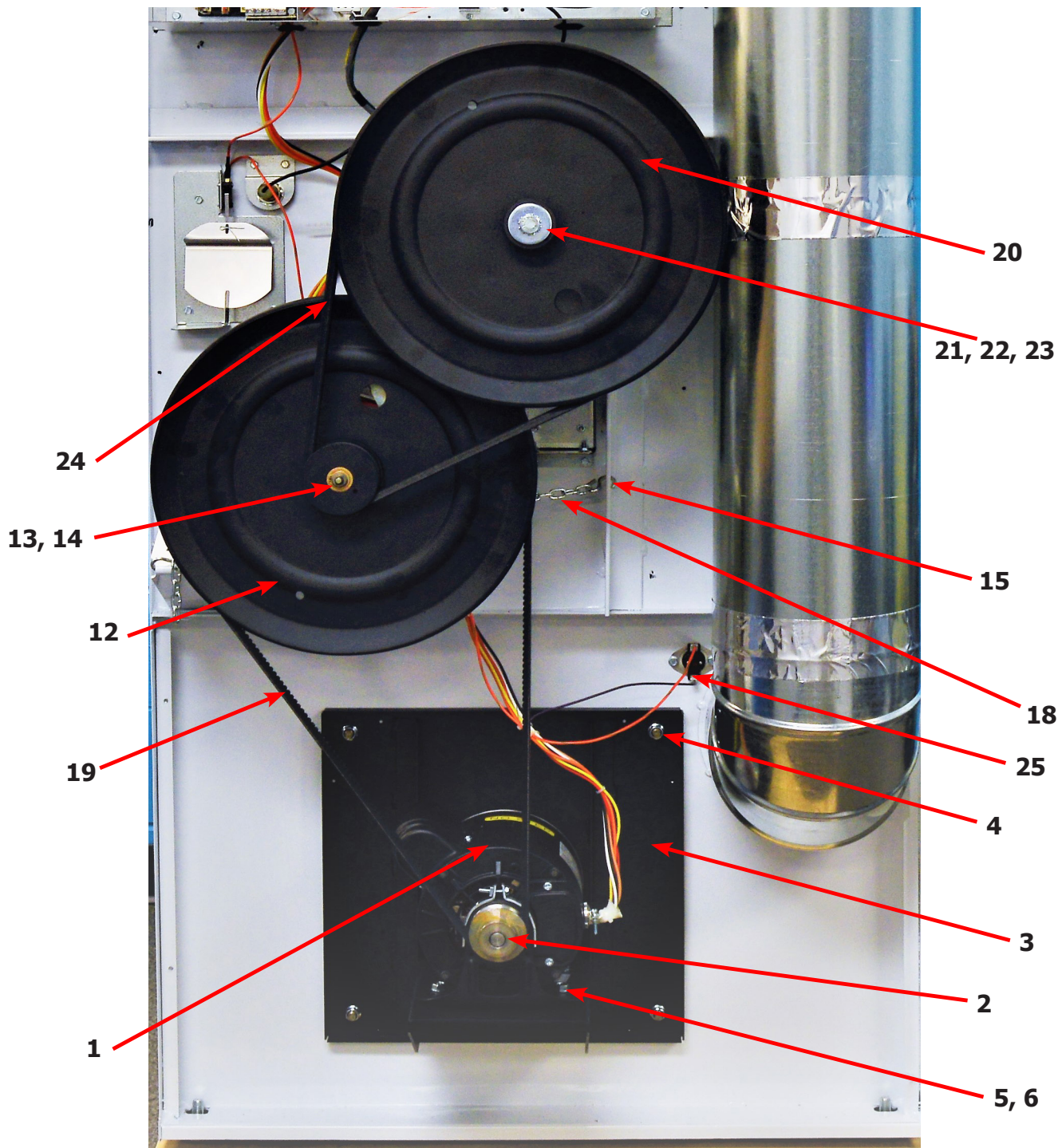

Dryer Rear View 50Lb

Key	Description	T-50	QTY
1	Motor	9376-317-001	1
2	Pulley	9453-169-013	1
*	Set screw	9545-028-013	1
3	Plate, Motor mounting	9982-370-002	1
*	Gasket, Motor Plate	9206-428-002	1
4	Nut-3/8-16, Plate to cabinet	8640-415-004	4
*	Impeller w/set screw	9278-037-003	1
5	Screw, 5/16-18x5/8	9545-014-004	4
6	Nut, 5/16-18	8640-400-003	4
7	Support Arm, Intermediate pulley	9991-053-002	1
8	Bolt- 3/8-16x1 1/4	9545-029-010	3
9	Nut, Wizlock, 3/8x16	8640-415-004	3
*	Cap Screw, 3/8-16x1 1/2	9545-029-012	1
*	Snap Ring	9487-200-003	1
*	Washer-Flat, 3/8x1	8641-581-035	3
10	Idler Arm Assembly	9861-022-002	1
11	Washer-Flat, 3/8x1	8641-581-035	2
12	Pulley, Idler w/Bearings	9908-048-003	1
13	Bearing, Bronze	9036-145-002	2
14	Snap Ring	9487-200-003	1
15	Hook "S" type	9248-022-002	3
16	Chain, Spring tension	9099-012-002	1
17	Spring, tension	9534-319-002	1
18	Chain, Limit		1
19	Belt Drive	9040-076-006	1
*	Tolerance Ring	9487-234-005	1
20	Pulley, Driven	9908-047-002	1
21	Washer-Flat, 1/2	8641-581-026	1
22	Washer-Lock, Ext. tooth, 1/2	8641-582-016	1
23	Bolt-3/4, 1/2-13x1 1/4	9545-017-009	1
24	Belt, Driven	9040-073-011	1
25	Thermostat-safety reset	9576-207-006	1
*	Screw-hxwshrndrcuthd,10abx3/8	9545-008-024	2

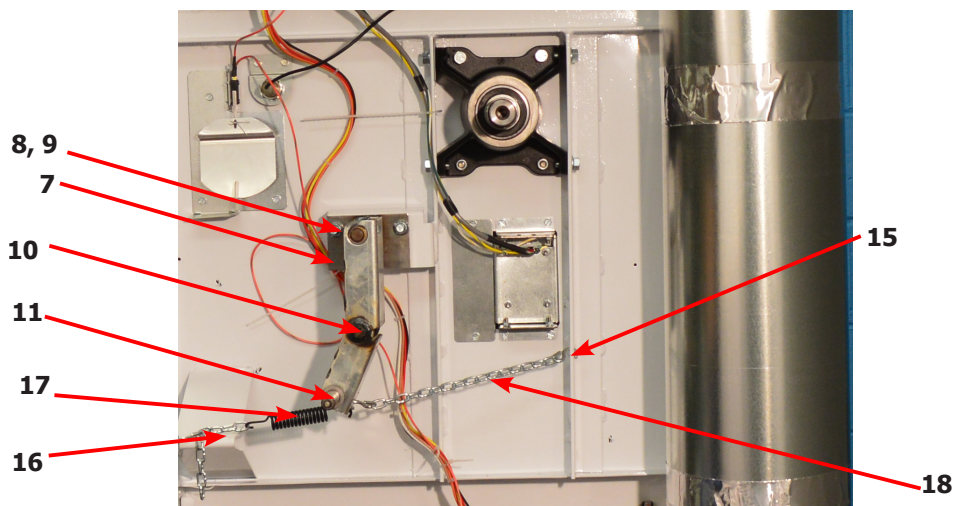

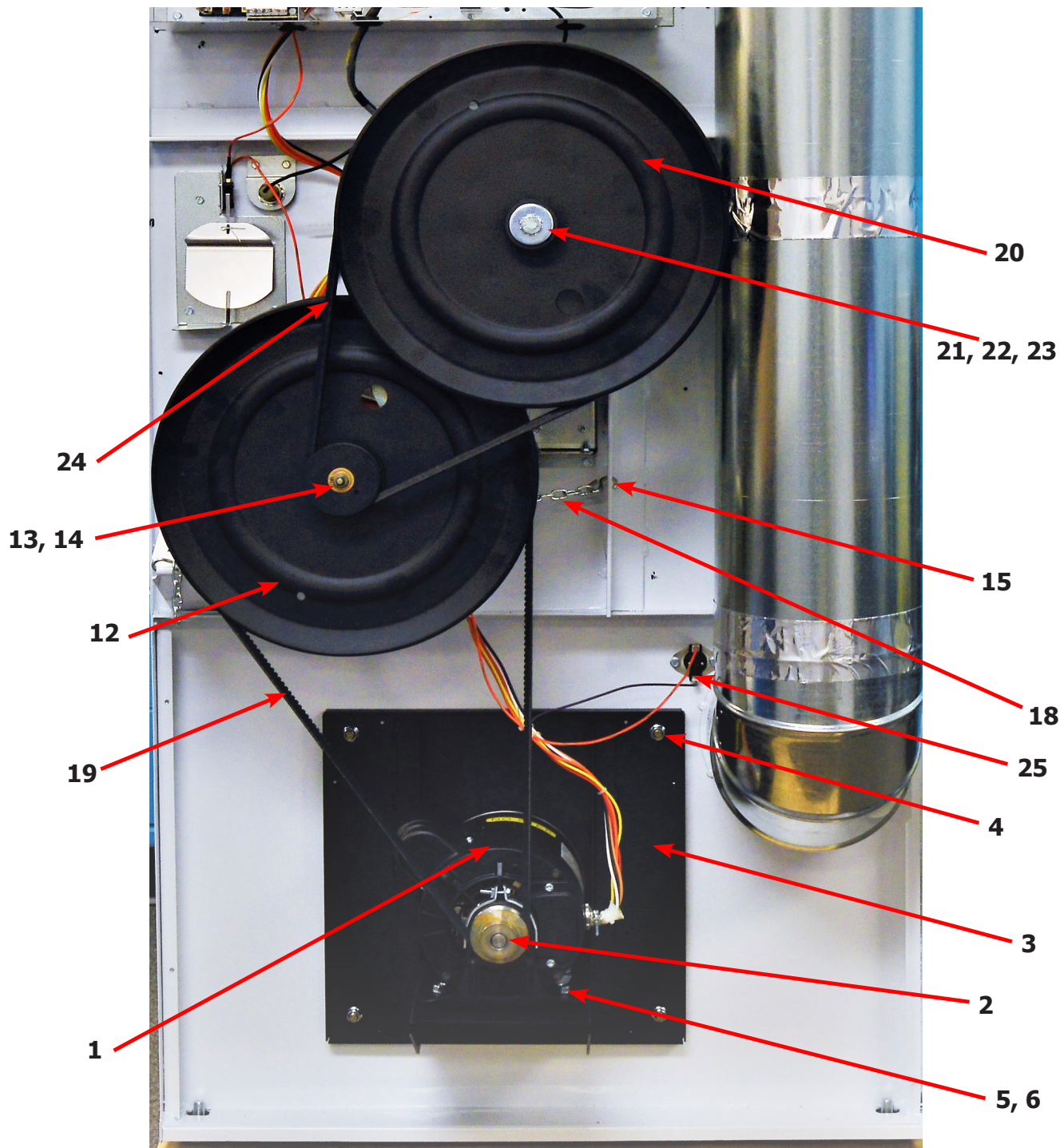

Key	Description	T-80	QTY
1	Motor	9376-317-001	1
2	Pulley	9453-157-001	1
*	Set screw	9545-028-013	1
3	Plate, Motor mounting	9982-372-002	1
*	Gasket, Motor Plate	9206-428-002	1
4	Nut-3/8-16, Plate to cabinet	8640-415-004	4
*	Impeller w/set screw	9278-037-003	1
5	Screw, 5/16-18x5/8	9545-014-004	4
6	Nut, 5/16-18	8640-400-003	4
*	Tolerance Ring	9487-234-001	1
7	Pulley, Driven	9908-043-002	1
8	Washer-Flat, 1/2	8641-581-026	1
9	Washer-Lock, Ext. tooth, 1/2	8641-582-016	1
10	Bolt-3/4, 1/2-13x1/14	9545-017-009	1
11	Support Arm, Intermediate pulley	9991-053-002	1
12	Bolt- 3/8-16x1 1/4	9545-029-010	3
13	Nut, Wizlock, 3/8x16	8640-415-004	3
*	Cap Screw, 3/8-16x1 1/2	9545-029-012	1
*	Snap Ring	9487-200-003	1
*	Washer-Flat, 3/8x1	8641-581-035	1
14	Idler Arm Assembly	9861-024-004	1
*	Snap Ring	9487-200-006	1
*	Washer-Flat,	8641-581-039	1
15	Pulley, Idler w/Bearings	9908-042-006	1
*	Snpring, Inside-Bearing	9487-238-005	1
*	Bearing, Ball	9036-159-007	2
*	Spacer, Bearing	9538-173-002	1
16	Washer-Flat	8641-581-039	1
17	Nut, 5/8-11	8640-425-002	1
18	Hook "S" type	9248-022-002	3
19	Chain, Spring tension	9099-012-009	1
20	Spring, tension	9534-151-000	1
21	Belt Drive	9040-076-011	1
22	Belt, Driven	9040-073-012	1
23	Thermostat-Overtemp, Reset	9576-207-006	1
*	Plug-plastic,7/8"	9456-041-006	1

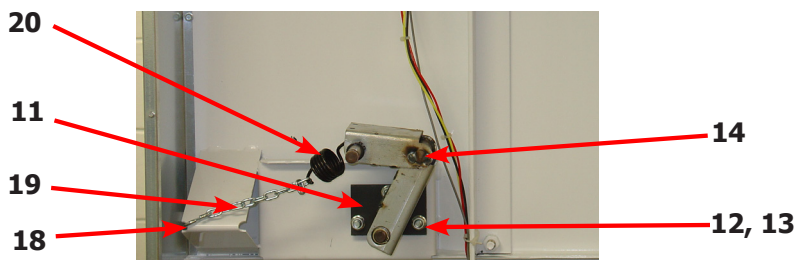

Dryer Rear View 80 Lb

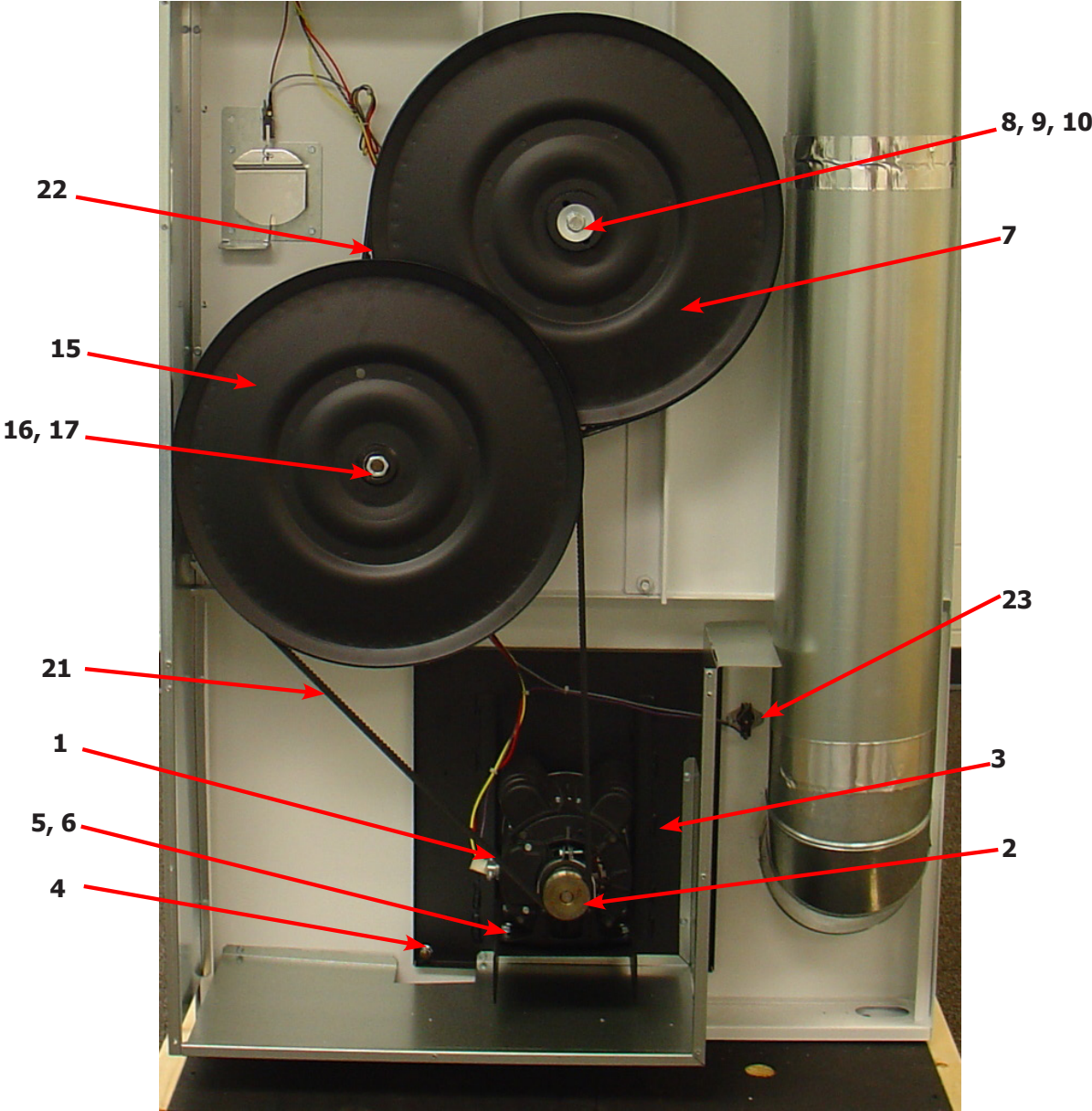

Dryer Rear View-Guard & Exhaust

Key	Description	T-30	T-50	T-80	QTY
1	Cover Cabinet	9074-347-001	9074-348-001	9074-349-001	1
*	Screw-5/16, 10ABx3/8	9545-008-024	9545-008-024	9545-008-024	AR
2	Cover-Control Box	9074-346-001	9074-353-001	9074-346-001	1
3	Screw-5/16, 10ABx3/8	9545-008-024	9545-008-024	9545-008-024	AR
4	Guard, RH	9208-093-001	9208-097-001	9208-101-001	1
*	Screw-5/16, 10ABx3/8	9545-008-024	9545-008-024	9545-008-024	AR
5	Guard Base & LH	9208-094-001	9208-098-001	9208-102-001	1
*	Screw-5/16, 10ABx3/8	9545-008-024	9545-008-024	9545-008-024	AR
6	Guard-Lower	9208-095-001	9208-099-001	9208-103-001	1
7	Screw-5/16, 10ABx3/8	9545-008-024	9545-008-024	9545-008-024	AR
8	Guard-upper	9208-150-001	9208-152-001	9208-105-001	1
*	Screw-5/16, 10ABx3/8	9545-008-024	9545-008-024	9545-008-024	AR
9	Elbow-90 degree, 8"	9142-039-001	9142-039-001	9142-039-001	1
10	Pipe-Duct, 8"	9109-121-001	9109-121-002	9109-121-002	1
11	Tee-Duct, Recirculation, 8"-6"	9810-018-001	9810-018-001	9810-019-001	1
12	Damper	9125-002-001		9125-008-001	1
*	Pin-Damper, Hinge	9451-146-002		9451-146-002	1
*	Nut-Spring	8520-141-000		8520-141-000	2
13	Bracket-Recirculation Duct, Small	9029-228-001	9029-228-001	9029-228-001	1
*	Screw-hxwshrndrcuthtd,10abx3/8	9545-008-024	9545-008-024	9545-008-024	2
14	Pipe-Duct, 6"	9109-122-001	9109-122-003	9109-122-003	1
15	Bracket-Duct, Recirculation Large	9029-246-001	9029-247-001	9029-247-001	1
*	Screw-hxwshrndrcuthtd,10abx3/8	9545-008-024	9545-008-024	9545-008-024	2
16	Elbow-90 degree, 6"	9142-039-002	9142-039-002	9142-039-002	1
*	Booklet-Owners	8514-291-001	8514-291-001	8514-291-001	1
17	Wiringlabel-diagram/inform	9507-017-001	9507-036-001	9507-040-001	1
	Wiringlabel-schematic	9508-017-001	9507-036-001	9508-040-001	
18	Label-Warning & Notice	8502-763-001	8502-763-001	8502-763-001	1
19	Label-Instructions (English)	8502-645-001	8502-645-001	8502-645-001	1
	Label-Instructions (French)	8502-645-002	8502-645-002	8502-645-002	
20	Decal-Lighting & Clearance (English)	8527-151-001	8527-151-001	8527-151-001	1
	Decal-Lighting & Clearance (French)	8527-151-002	8527-151-002	8527-151-002	
21	Label-High Voltage	8502-614-004		8502-614-001	1

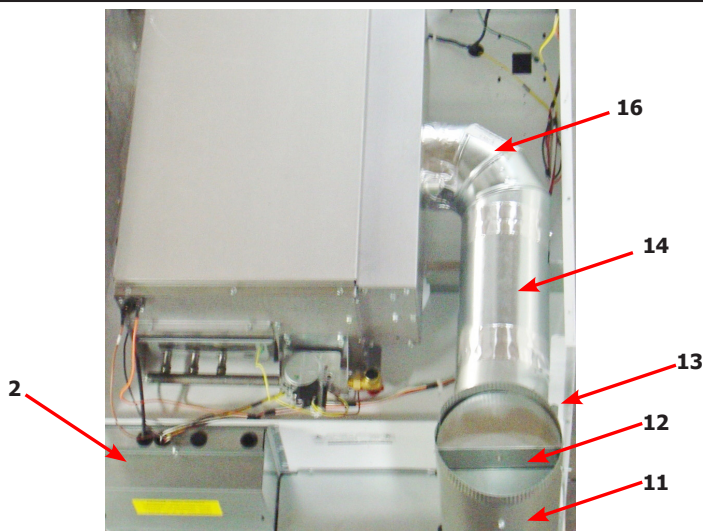

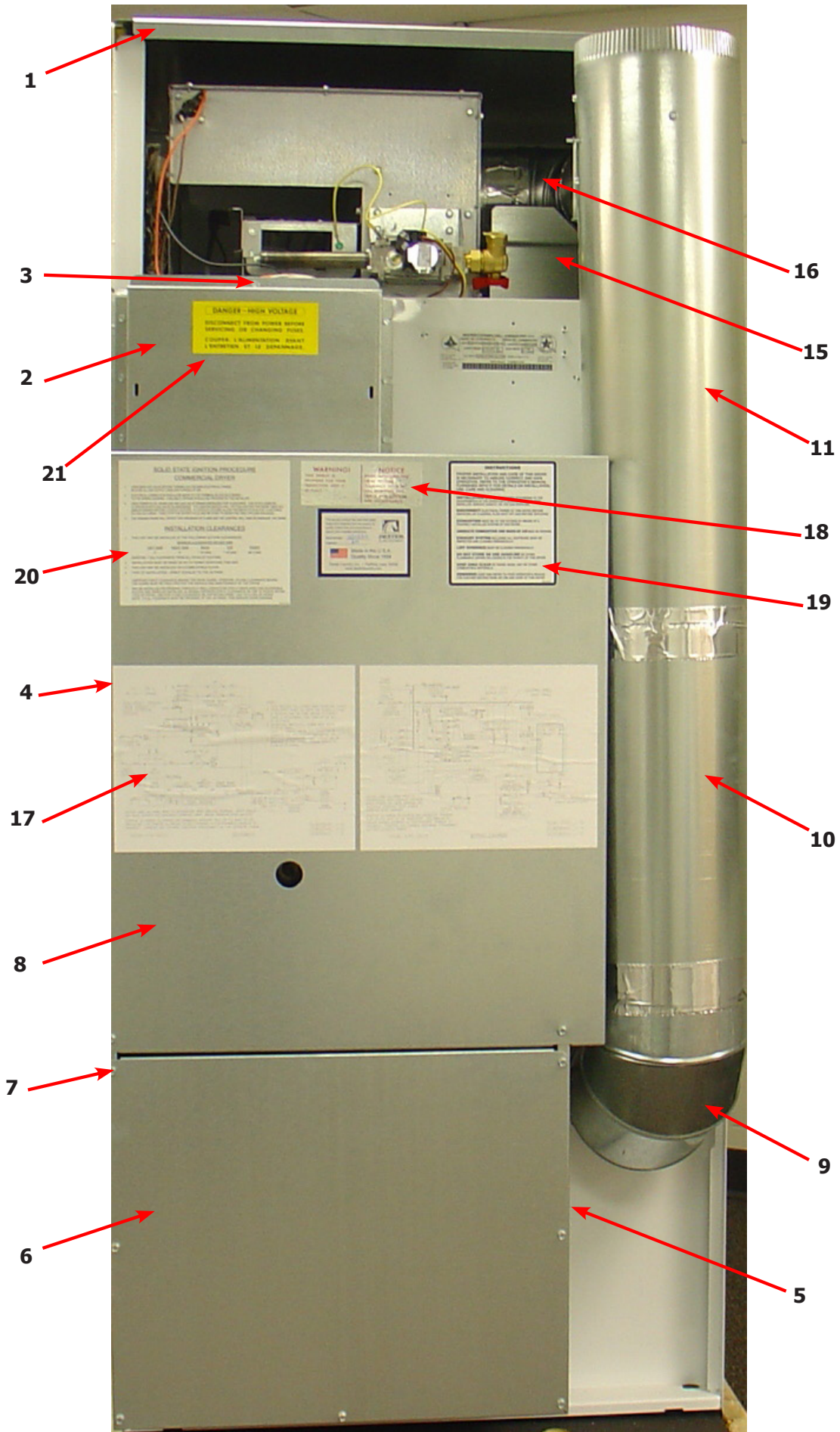

Dryer Rear View-Bearing Housing 30Lb

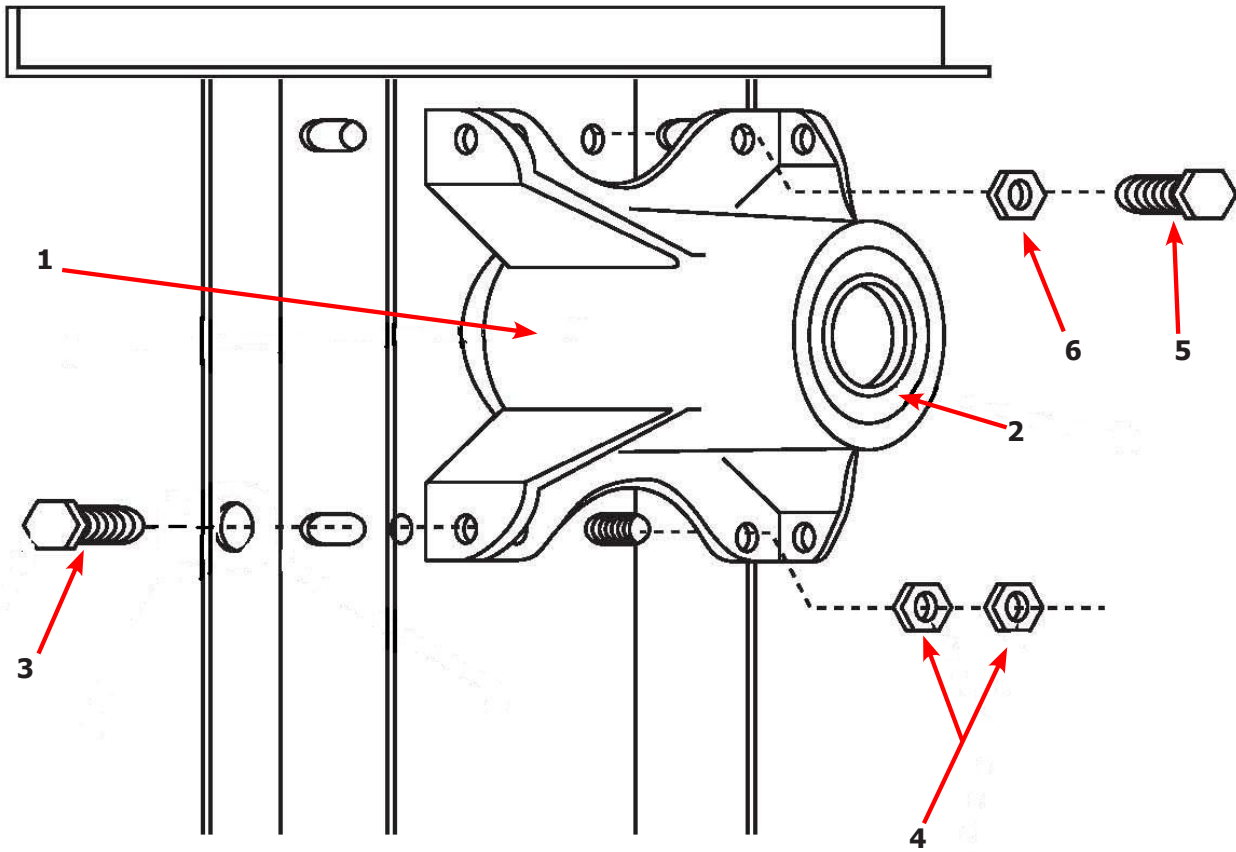

Key	Description	T-30	QTY
*	Bearing Housing Complete Assy (Includes bearings & Spacer)	9803-160-003	1
1	Housing, Bearing	9241-161-002	1
*	Bearing, Ball, Front	9036-130-001	1
*	Spacer, Bearing	9538-139-002	1
2	Bearing, Ball, Rear	9036-130-001	1
3	Screw-Wizlock, 3/8-24x3/4	9545-049-002	4
4	Nut, 5/16-18	8640-400-002	4
5	Screw, 3/8-24x1	9545-049-001	2
6	Nut, 3/8-24	8640-415-002	2
*	Shim, Tumbler	9552-013-003	AR

Dryer Tumbler Group 30Lb

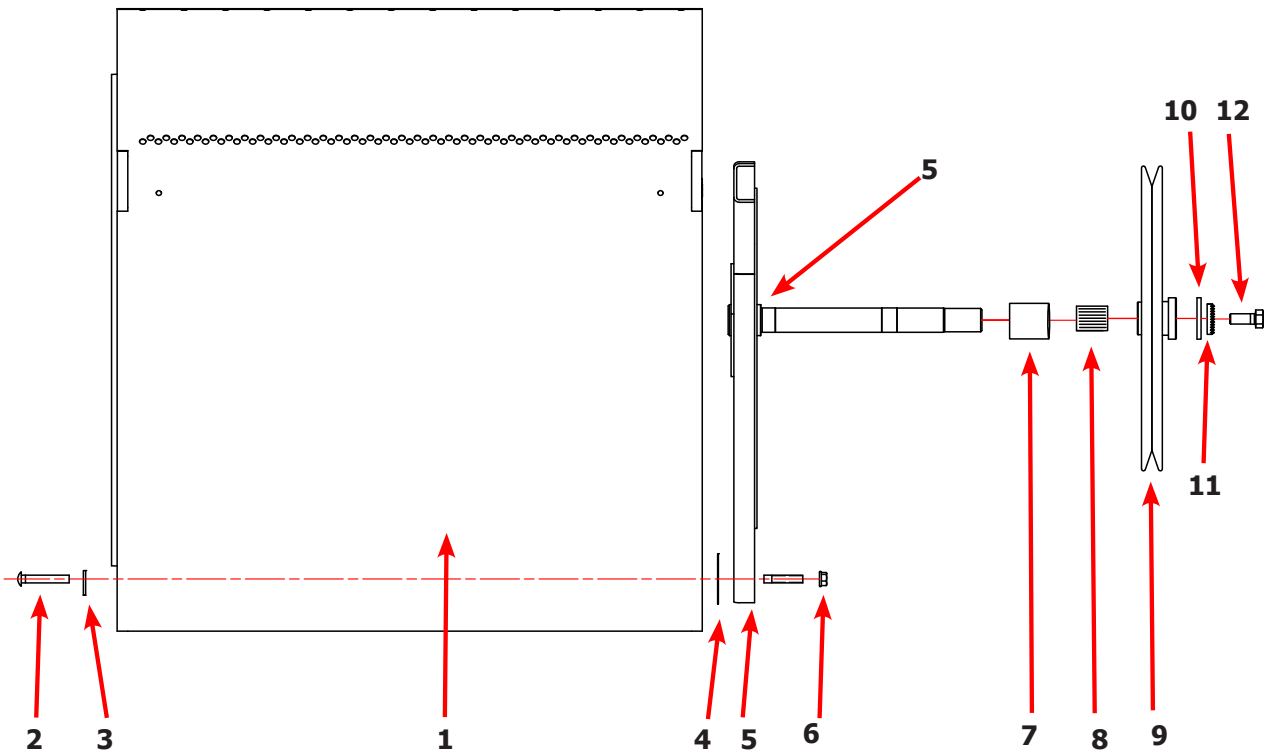

Key	Description	T-30	QTY
*	Tumbler Assy Complete W/Spider (GALV)	9848-147-003	1
1	Tumbler Assy (Galvanized)	9848-146-004	1
1	Tumbler Assy Complete W/Spider (SS & Galv front)	9848-147-004	1
1	Tumbler Assy (Stainless Galvanized front)	9848-146-005	1
2	Rod, Tumbler	9497-019-003	3
3	Washer, Special	8641-554-001	3
4	Shim	9552-013-000	AR
5	Spider Assy	9568-015-002	1
6	Nut, Wiz Lock	8640-415-004	3
7	Spacer-Shaft	9538-164-002	1
8	Tolerance Ring	9487-234-005	1
9	Pulley, Driven	9908-049-002	1
10	Washer -Flat	8641-581-026	1
11	LockWasher - IntTooth, 1"	8641-582-016	1
12	Screw, 1/2-13x1 1/4	9545-017-009	1

Dryer Rear View-Bearing Housing 50Lb

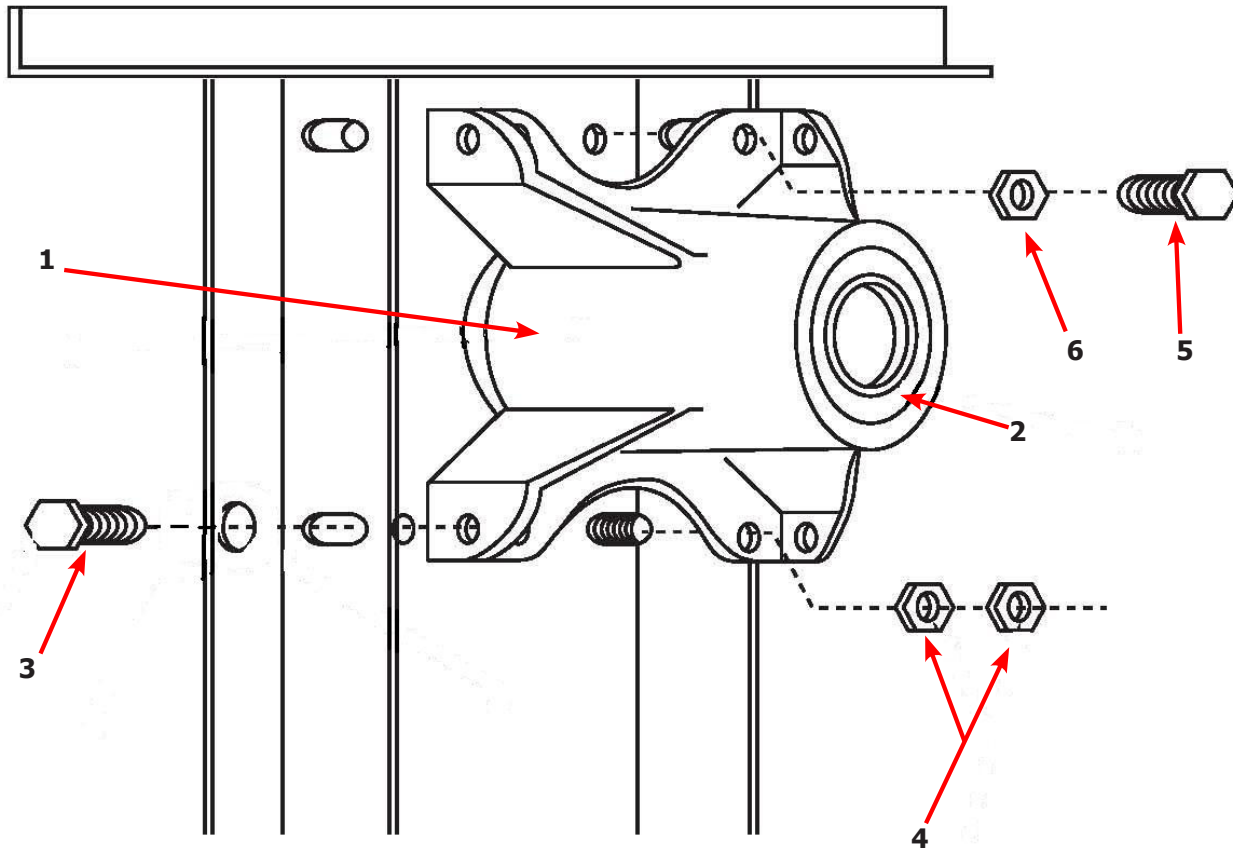

Key	Description	T-50	QTY
*	Bearing Housing Complete Assy (Includes bearings & Spacer)	9803-201-001	1
1	Housing, Bearing	9241-189-002	1
*	Bearing, Ball, Front	9036-159-001	1
*	Spacer, Bearing	9538-183-001	1
2	Bearing, Ball, Rear	9036-159-003	1
3	Screw-Wizlock, 1/2-13x3/4	9545-017-017	4
5	Screw, 1/2-13x1 1/2	9545-017-018	2
6	Nut, 1/2-13	8640-417-002	2
*	Shim, Tumbler	9552-013-003	AR

Dryer Tumbler Group 50Lb

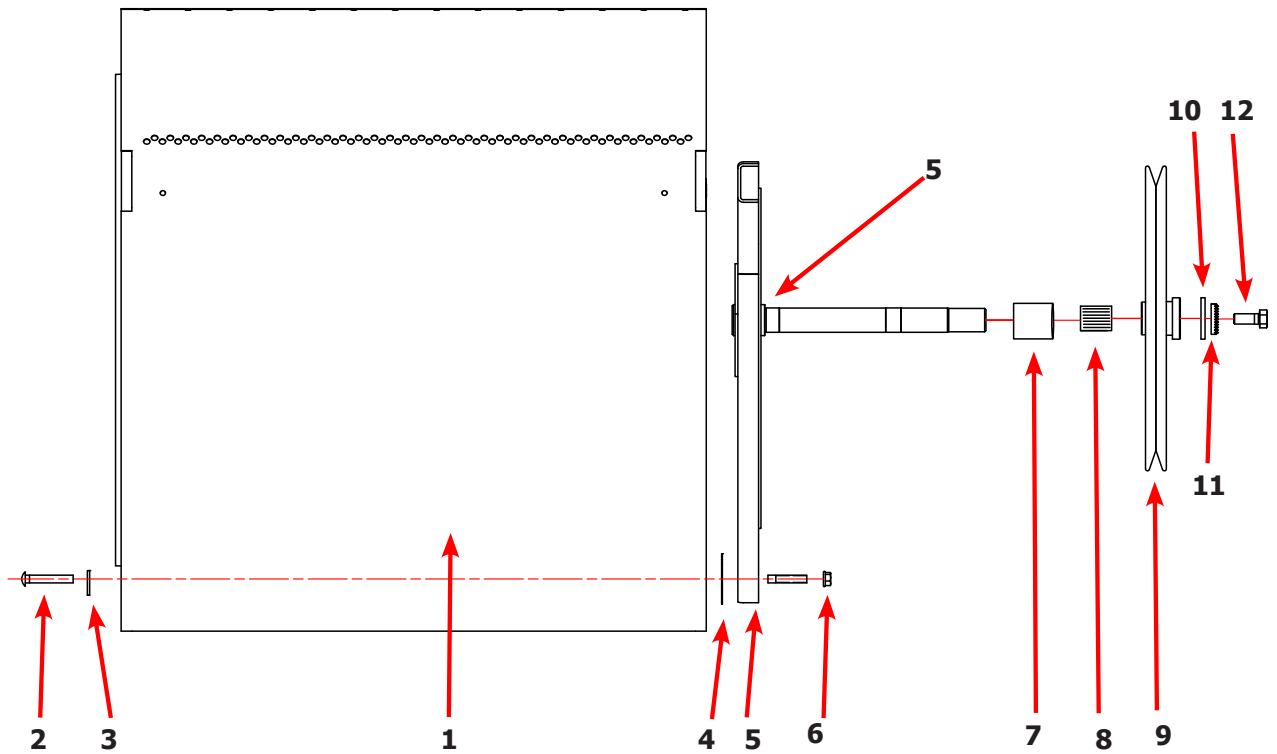

Key	Description	T-50	QTY
*	Tumbler Assy Complete W/Spider (GALV)	9848-158-003	1
1	Tumbler Assy (Galvanized)	9848-157-003	1
1	Tumbler Assy Complete W/Spider (SS & Galv front)	9848-158-004	1
1	Tumbler Assy (Stainless Galvanized front)	9848-157-004	1
2	Rod, Tumbler	9497-226-002	3
3	Washer, Special	8641-590-002	3
4	Shim	9552-013-000	AR
5	Spider Assy	9568-017-002	1
6	Nut, Wiz Lock	8640-417-005	3
7	Spacer-Shaft	9538-184-001	1
8	Tolerance Ring	9487-234-005	1
9	Pulley, Driven	9908-047-002	1
10	Washer -Flat	8641-581-026	1
11	LockWasher - IntTooth, 1"	8641-582-016	1
12	Screw, 1/2-13x1 1/4	9545-017-009	1

Dryer Rear View-Bearing Housing 80Lb

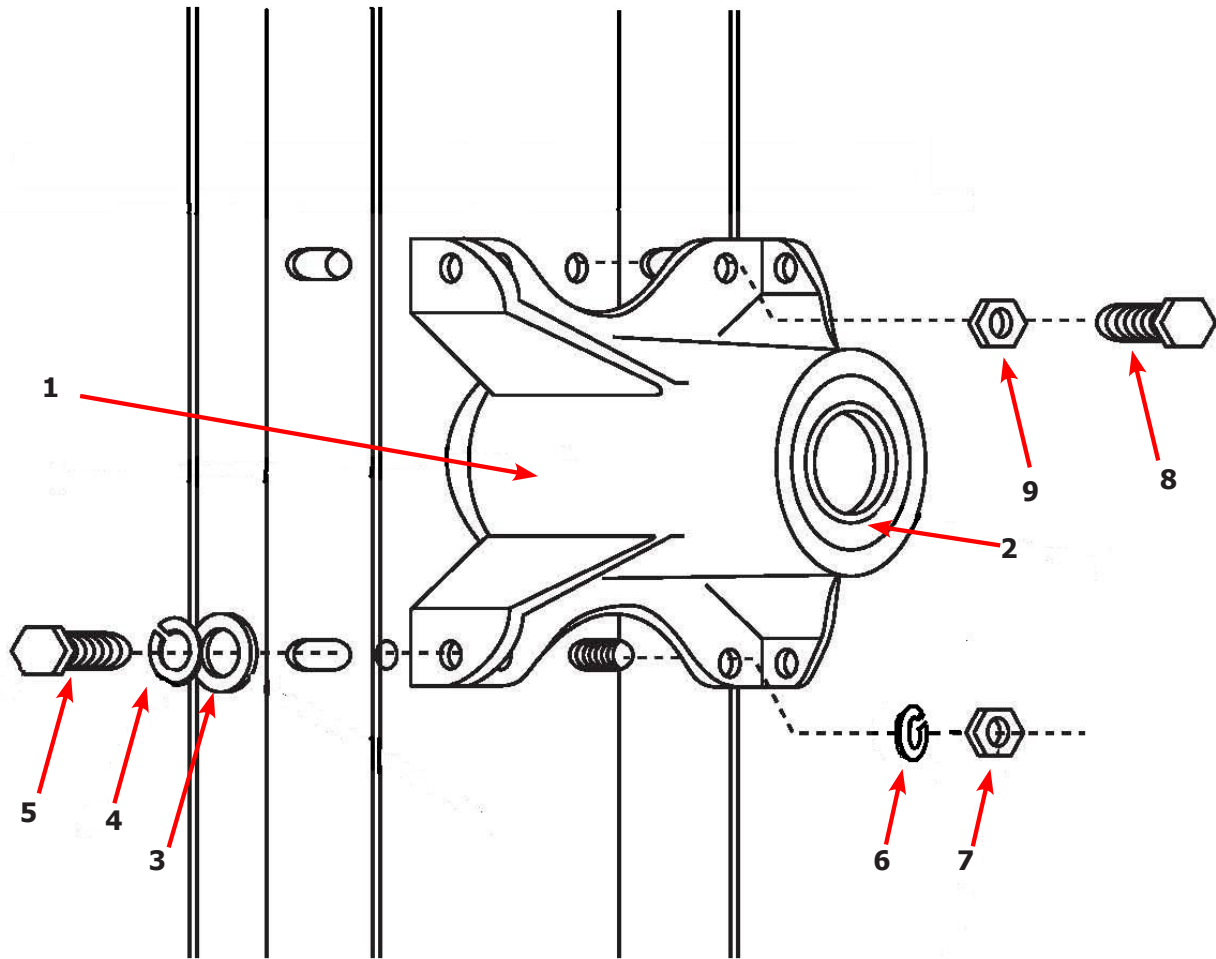

Key	Description	T80	QTY
	Bearing Housing Complete Assy (Includes bearings & Spacer)	9803-189-001	1
1	Housing, Bearing	9241-183-003	1
*	Bearing, Ball, Front	9036-159-001	1
2	Bearing, Ball, Rear	9036-159-002	1
3	Washer, Flat 1/2	8641-581-026	4
4	Lock Washer Spring, 1/2	8641-582-004	2
5	Screw, 1/2-13x1	9545-017-004	4
6	Lock Washer Spring, 1/2	8641-582-004	4
7	Nut, 7/16-14	8640-416-001	2
8	Screw, 7/16-14x1 1/2	9545-059-003	2
9	Nut, 7/16-14	8641-416-001	2

Dryer Tumbler Group 80Lb

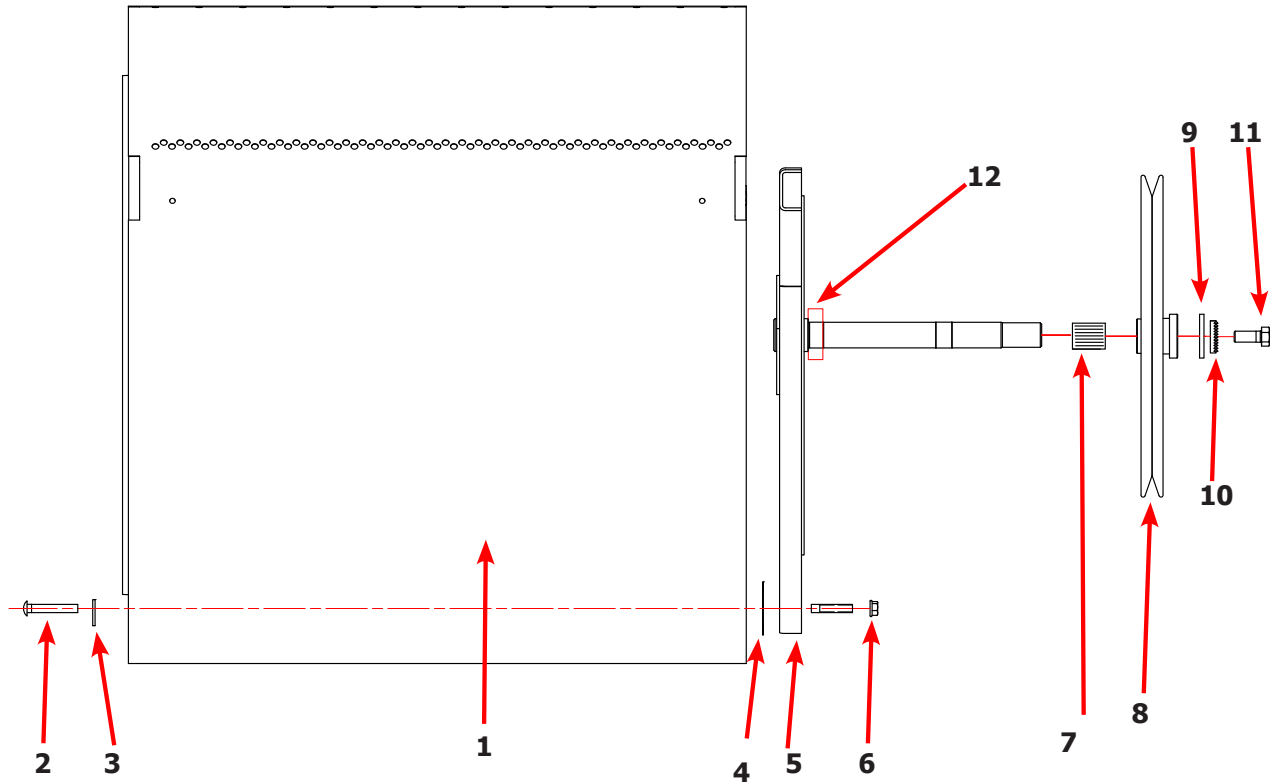

Key	Description	T80	QTY
*	Tumbler Assy Complete W/Spider (GALV)	9848-151-005	1
1	Tumbler Assy (Galvanized)	9848-150-005	1
1	Tumbler Assy Complete W/Spider (SS & Galv front)	9848-151-006	1
1	Tumbler Assy (Stainless Galvanized front)	9848-150-006	1
2	Rod, Tumbler	9497-226-001	4
3	Washer, Special	8641-590-001	4
4	Shim	9552-013-000	AR
5	Spider Assy w/Front Bearing	9873-008-001	1
6	Nut, Wiz Lock	8640-417-005	4
7	Tolerance Ring	9487-234-001	1
8	Pulley, Driven	9908-043-002	1
9	Washer -Flat	8641-581-026	1
10	LockWasher - IntTooth, 1"	8641-582-016	1
11	Screw, 1/2-13x1 1/4	9545-017-009	1
12	Bearing, Front	9036-159-002	1

RMC Parts

Key	Description	T-30	T-50	T-80	QTY
1	Strip-sensing,moisture	9558-034-001	9558-034-001	9558-034-001	1
*	Rivet-blind,3/16steel	9491-009-001	9491-009-001	9491-009-001	6
2	Controlsassy-rotatingpcb,rmc	9857-248-001	9857-248-001	9857-248-001	1
*	Screw-hxwshrundrcuthd,10abx3/8	9545-008-024	9545-008-024	9545-008-024	2
3	Wiringharness-rmc,sensor,	9627-941-001	9627-941-002	9627-941-003	1
4	Conduit-rmcwires,	6068-052-001	6068-053-001	6068-054-001	1
*	Screw-hxwshrundrcuthd,10abx3/8	9545-008-024	9545-008-024	9545-008-024	2
5	Grommet-3/16id	9209-037-002	9209-037-002	9209-037-002	1
6	Screw-hxwshdsl,10-32tx1/2grn	9545-008-027	9545-008-027	9545-008-027	1
*	Lockwasher-exttooth,#10	8641-582-006	8641-582-006	8641-582-006	1
7	Bracketassy-cabinet,rmc	9985-204-001	9985-204-001	9985-204-001	2
*	Screw-hxwshdsl,10bx1/4	9545-008-001	9545-008-001	9545-008-001	4
8	Controlsassy-stationarypcb,rmc	9857-247-001	9857-247-001	9857-247-001	1
*	Nut-hexkeps,#10-32unf,2b	8640-413-002	8640-413-002	8640-413-002	2
9	Wiringharn-rmc,can/pwr,	9627-940-001	9627-940-001	9627-940-002	1
10	Cover-service,rmc	9074-385-001	9074-385-001	9074-385-001	1
*	Screw-hxwshdsl,10bx1/4	9545-008-001	9545-008-001	9545-008-001	2

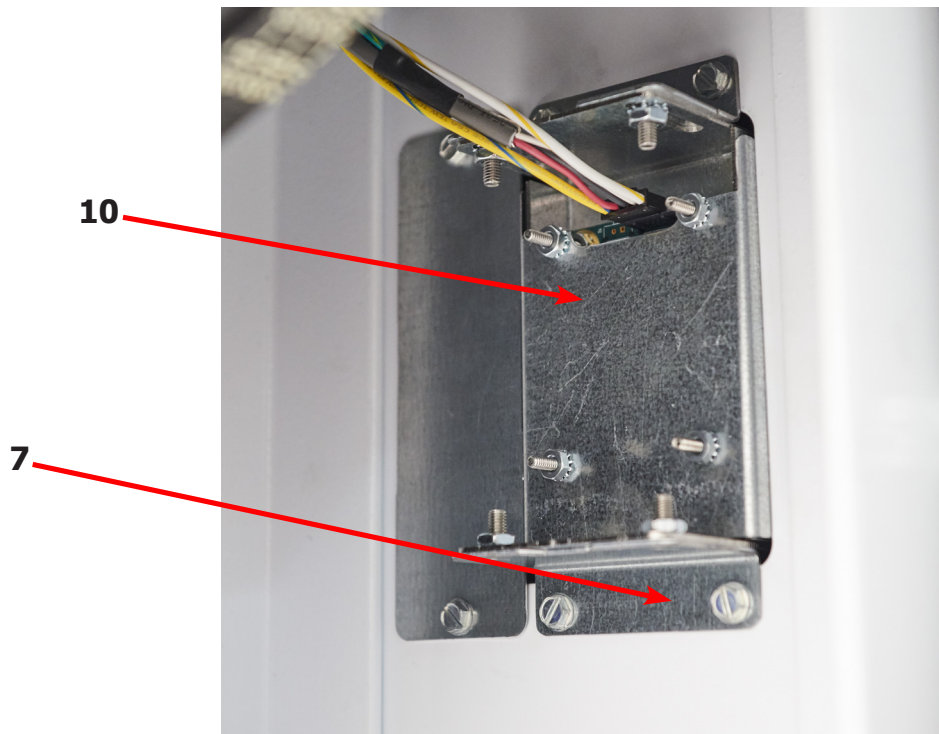

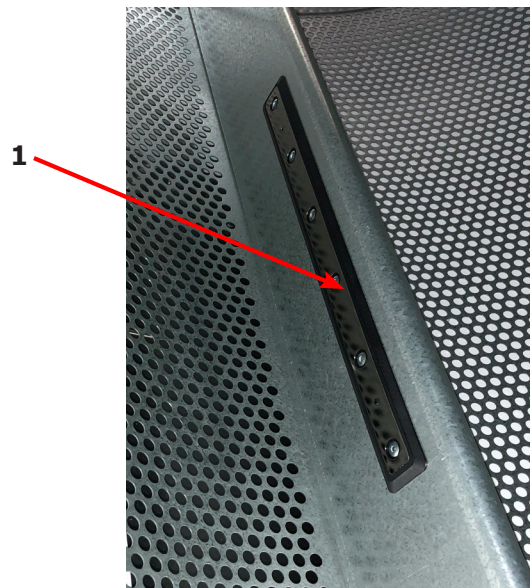
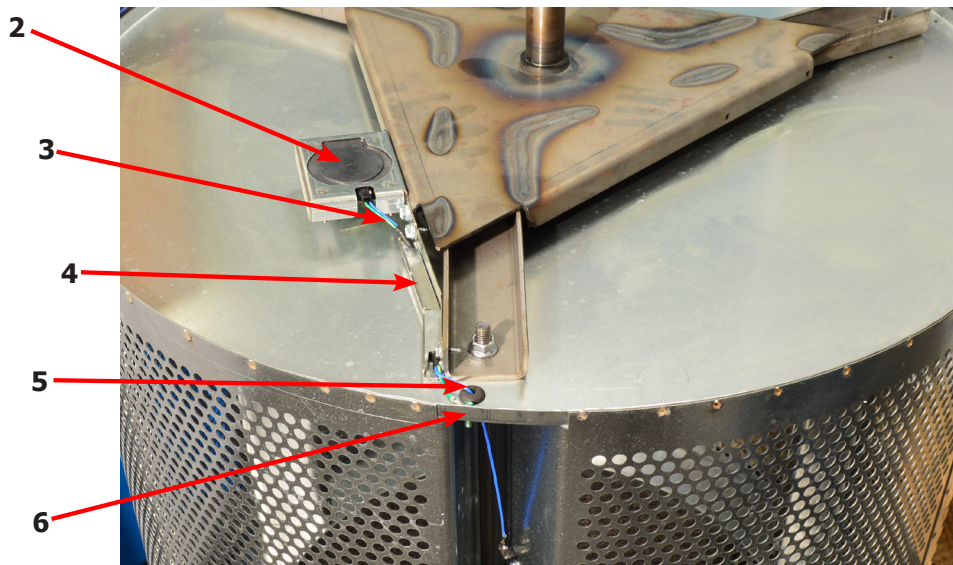
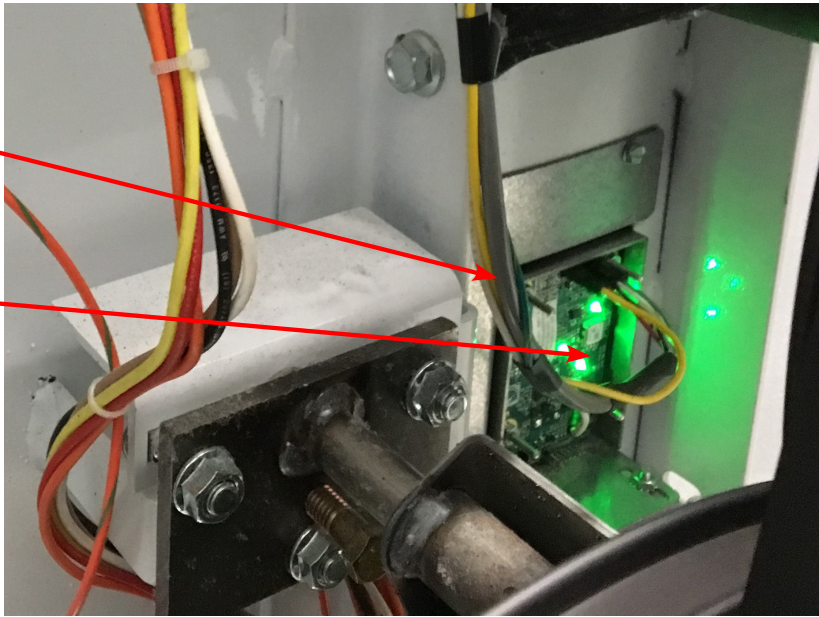

Water Suppression Parts

Key	Description	T-30	T-50	T-80	QTY
1	Nozzleassy-firesuppression	9872-004-001	9872-004-001	9872-004-001	1
*	Screw-hxwshrndrcuthd,10abx3/8	9545-008-024	9545-008-024	9545-008-024	3
2	Tube-nozzle,inlet	9574-261-001	9574-261-001	9574-261-001	1
3	Bushing-support	9053-083-001	9053-083-001	9053-083-001	1
*	Screw-hxwshrndrcuthd,10abx3/8	9545-008-024	9545-008-024	9545-008-024	1
4	Fitting-adapt,3/8nptto1/2hose	8615-115-001	8615-115-001	8615-115-001	1
5	Valve-water,24v,epdm(nsf)	9379-183-013	9379-183-013	9379-183-013	1
6	Wireasy-jumper,org/brn,101-6	8220-161-001	8220-161-001	8220-161-001	1
7	Wireasy-jumper,wht/org,60"-6"	8220-090-019	8220-090-019	8220-090-019	1
8	Screw-hxwshrhdndct,#10bx1/2	9545-008-026	9545-008-026	9545-008-026	2
9	Hose-water,3"	9242-453-031	9242-453-031	9242-453-031	2
10	Fitting-y,1/2	8615-119-001	8615-119-001	8615-119-001	1
11	Hose-water,"	9242-453-032	9242-453-033	9242-453-033	1
*	Clamp-hose,worm,1in	8654-117-015	8654-117-015	8654-117-015	6
*	Clamp-cable	8654-061-001	8654-061-001	8654-061-001	2
*	Screw-hxwshrndrcuthd,10abx3/8	9545-008-024	9545-008-024	9545-008-024	2
12	Guard-watervale	9208-145-001	9208-145-001	9208-145-001	1
*	Screw-hxwshrndrcuthd,10abx3/8	9545-008-024	9545-008-024	9545-008-024	2
13	Thermostat-fss	9576-212-001	9576-212-001	9576-212-001	1
*	Screw-hxwshdsltld,8bx1/2	9545-045-002	9545-045-002	9545-045-002	2
	Wireasy-jumper,org,77"	8220-162-001	8220-162-001	8220-162-001	1
14	Pcbassy-relay	9799-028-001	9799-028-001	9799-028-001	1
*	Screw-hxwshrndrcuthd,10abx3/8	9545-008-024	9545-008-024	9545-008-024	2
15	Wireasy-jumper,v2.0,relaypcb	8220-159-006	8220-159-006	8220-159-006	1
16	Wiringharness-cntrl/relay,v2.0	9627-921-001	9627-921-001	9627-921-001	1
17	Switch-momentary,n.o.	9539-500-001	9539-500-001	9539-500-001	1
*	Wireasy-org,49"	8220-108-015	8220-108-015	8220-108-015	1
18	Wiringharness-relaypowerboard	9628-006-001	9628-006-001	9628-006-001	1
*	Wireasy-jumper,wht/org,5"	8220-161-002	8220-161-002	8220-161-002	1
*	Wireasy-org,11"	8220-108-014	8220-108-014	8220-108-014	1
19	Bracket-mtg,ohpsensor	9029-315-001	9029-315-001	9029-315-001	
*	Screw-hxwshrndrcuthd,10abx3/8	9545-008-024	9545-008-024	9545-008-024	

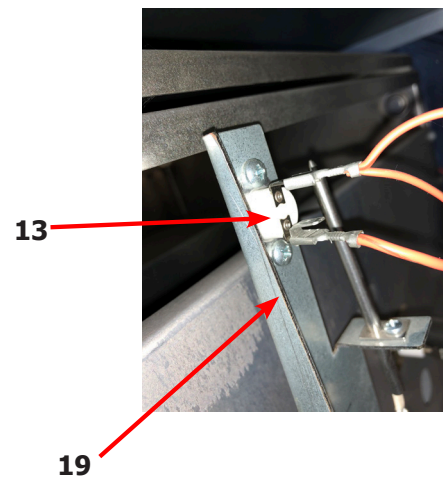
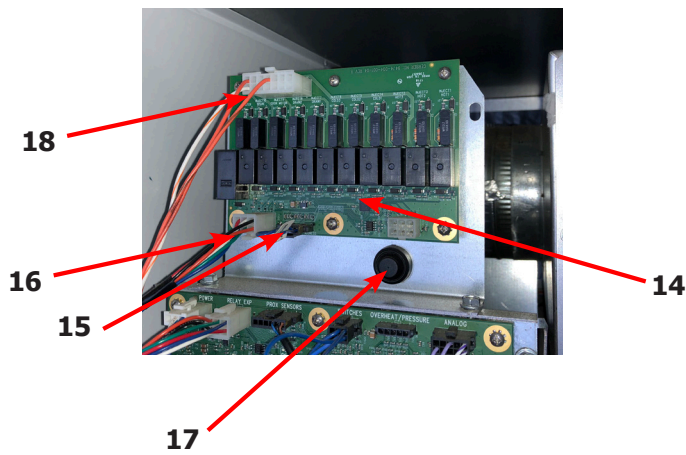
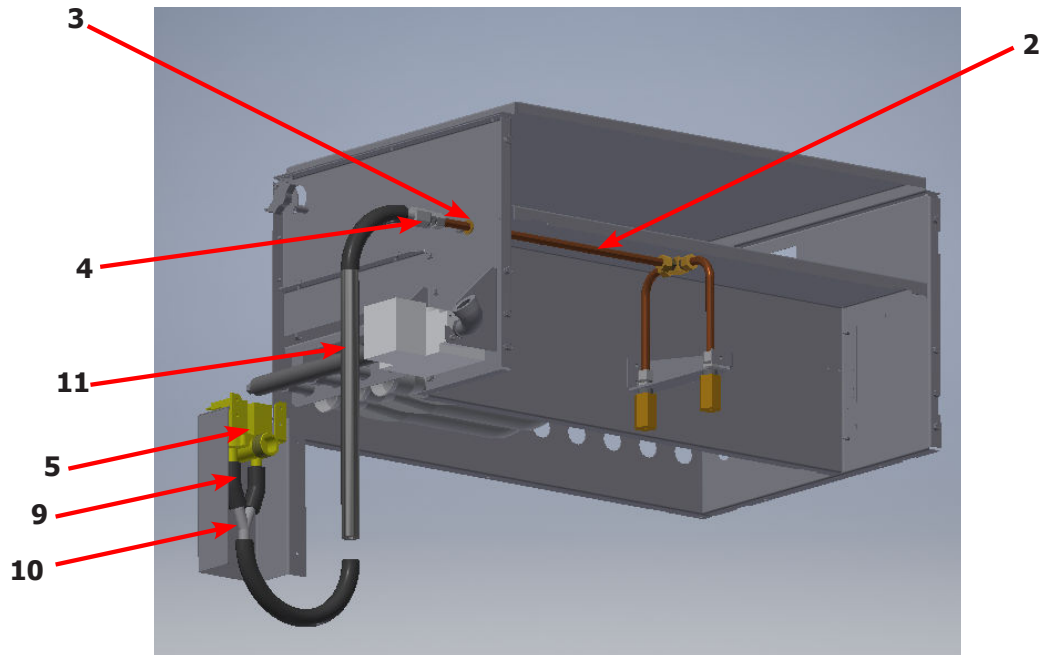
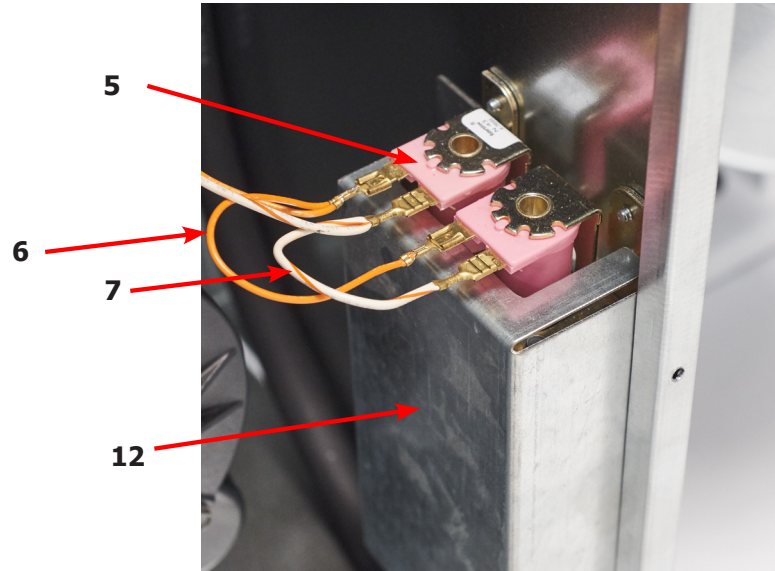

Dryer Burner Housing Group 30Lb

Key	Description	T-30	QTY
*	Housing Assembly, Burner	9803-210-001	1
1	Panel-Burner Housing, Side Left	9454-976-001	1
2	Baffle-Burner Housing, Center	9049-091-001	1
3	Panel-Burner Housing, Top	9454-975-001	1
4	Panel-Burner Housing, Front	9454-847-001	1
5	Panel-Burner Housing, Back	9454-848-001	1
7	Baffle-Burner Housing, Front	9049-093-001	1
8	Duct Adaptor, 6"x3" long	9109-120-001	1
9	Burner, Main	9048-021-001	2
10	Bracket-Support, Electrode	9029-214-001	1
11	Bracket-Support, Gas Valve	9029-227-001	1
12	Electrode-Ignition	9875-002-003	1
13	Control Assy,Gas Valve, White Rodgers 36J	9857-192-001	1
14	Manifold Assy	9381-009-007	1
16	Thermostat-HI-Limit	9576-203-002	1
*	Wireasy-org,#14,24"	8220-095-040	1
*	Wireasy-org,27"	8220-095-054	1
17	Screw, 10ABx3/8	9545-008-024	22
18	Screw, 10ABx1/4	9545-008-001	17
19	Orfice-Natural, .125	9425-069-023	2
*	Orfice-LP, #48	9425-069-003	2
*	Kit, LP Conversion, White Rodgers	9732-102-018	1
20	Bracket-Support, Burner	9029-225-001	1
21	Panel-Burner Housing, Side Right	9454-861-001	1
22	Screw, 10-32TTx1/2 Green	9545-008-027	3
23	Screw, 8-32x3/8	9545-010-014	4
24	Sensor-temp(thermistr),10k,wht	9501-004-004	1
25	Bracket-mtg,ohpsensor	9029-315-001	1
*	Screw-hxwshrundrcuthd,10abx3/8	9545-008-024	3
*	Screw-rdhdc,8bx1/4	9545-045-005	1
*	Nut-wireconn,#71b,blk	8640-276-005	2

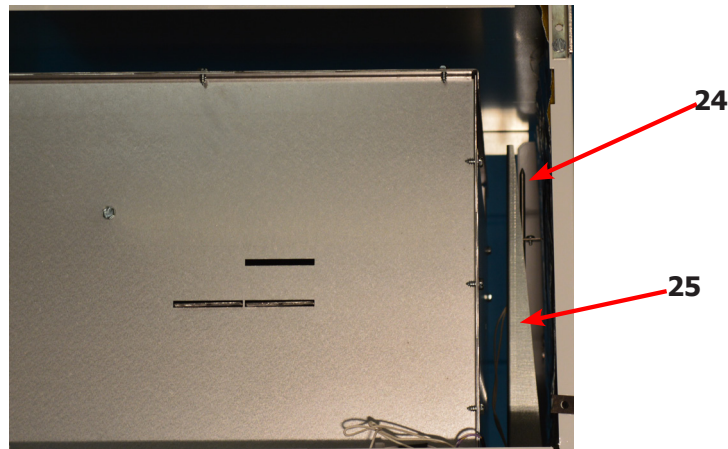

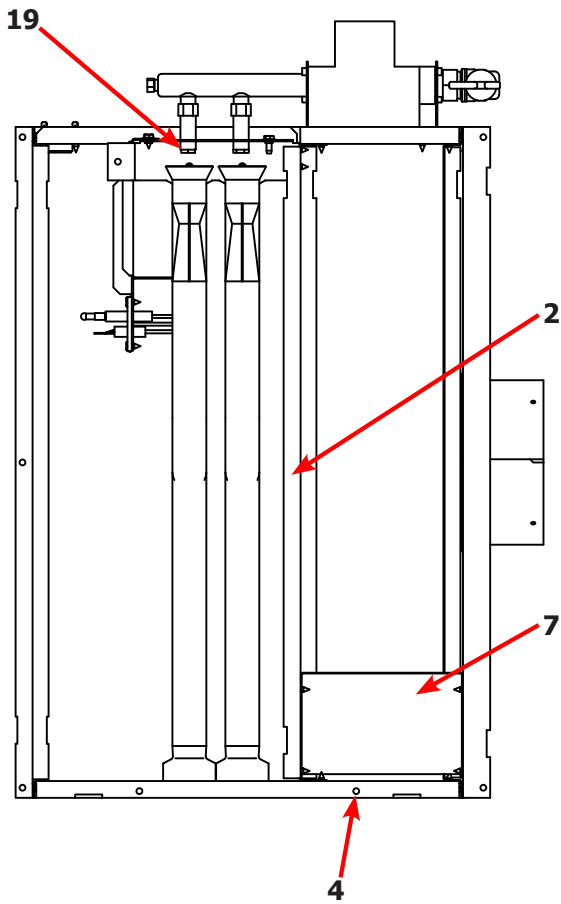
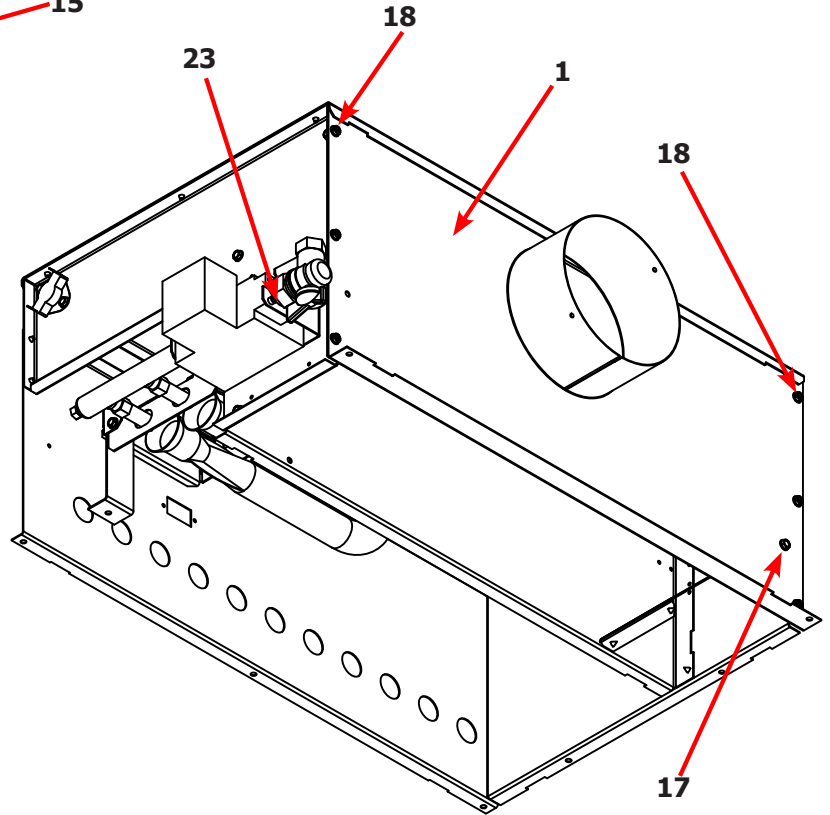
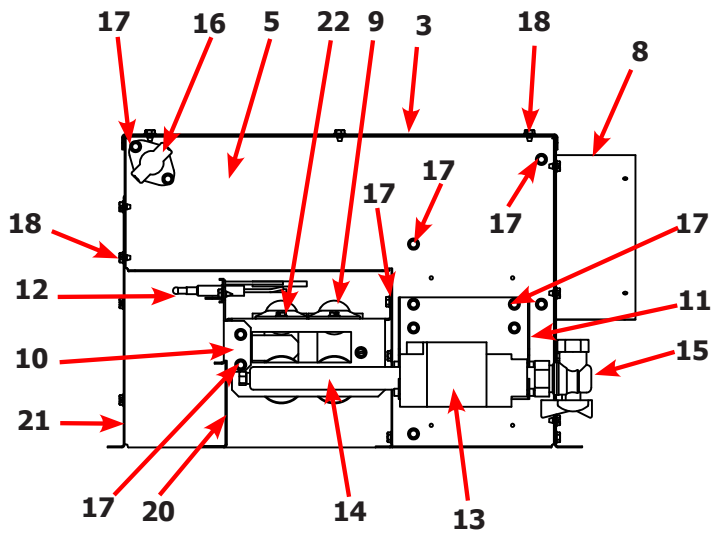

Dryer Burner Housing Group 50Lb

Key	Description	T-50	QTY
*	Housing Assembly, Burner	9803-211-001	1
1	Panel-Burner Housing, Side Left	9454-862-001	1
2	Baffle-Burner Housing, Center	9049-098-001	1
3	Panel-Burner Housing, Top	9454-977-001	1
4	Panel-Burner Housing, Front	9454-863-001	1
5	Panel-Burner Housing, Back	9454-864-001	1
7	Baffle-Burner Housing, Front		1
8	Duct Adaptor, 6"x3" long		1
9	Burner, Main	9048-021-001	2
10	Bracket-Support, Electrode		1
11	Bracket-Support, Gas Valve	9029-227-001	1
12	Electrode-Ignition	9875-002-003	1
13	Control Assy,Gas Valve, White Rodgers 36J	9857-192-001	1
14	Manifold Assy	9381-010-003	1
16	Thermostat-HI-Limit	9576-203-002	1
*	Wireasy-org,#14,24"		1
*	Wireasy-org,27"		1
17	Screw, 10ABx3/8		22
18	Screw, 10ABx1/4		17
19	Orfice-Natural, .125	9425-069-002	2
*	Orfice-LP, #48		2
*	Kit, LP Conversion, White Rodgers		1
20	Bracket-Support, Burner	9029-213-001	1
21	Panel-Burner Housing, Side Right	9454-861-001	1
22	Screw, 10-32TTx1/2 Green		3
23	Screw, 8-32x3/8		4
24	Sensor-temp(thermistr),10k,wht	9501-004-004	1
25	Bracket-mtg,ohpsensor	9029-315-001	1
*	Screw-hxwshrundrcuthd,10abx3/8	9545-008-024	3
*	Screw-rdhdc,8bx1/4	9545-045-005	1
*	Nut-wireconn,#71b,blk	8640-276-005	2

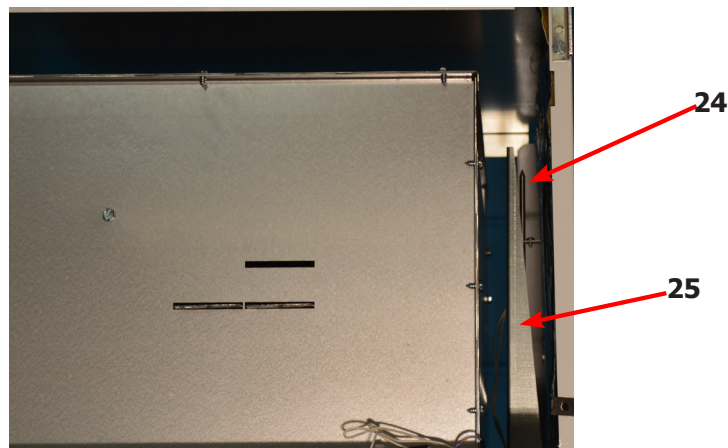

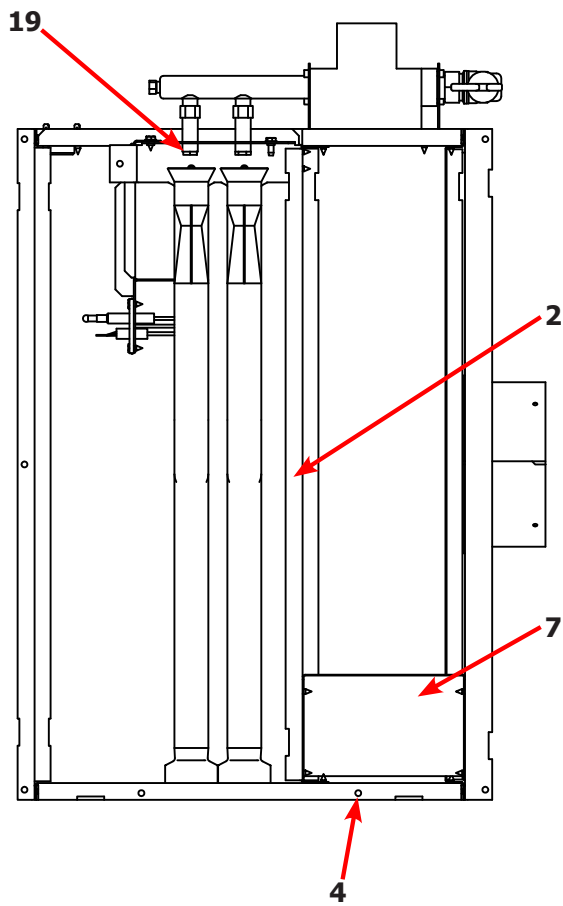
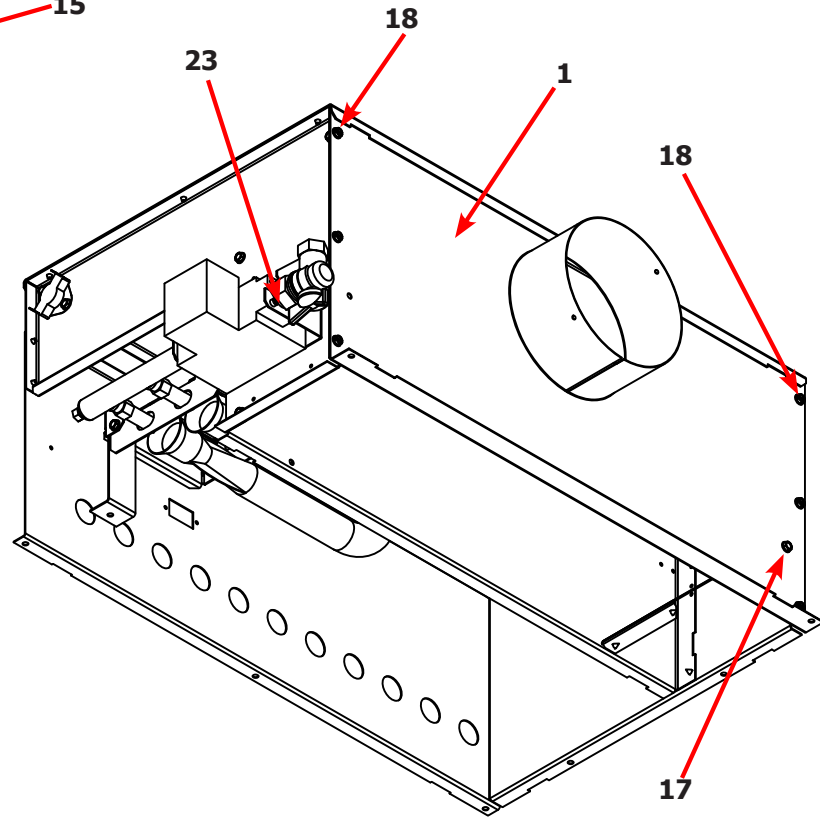
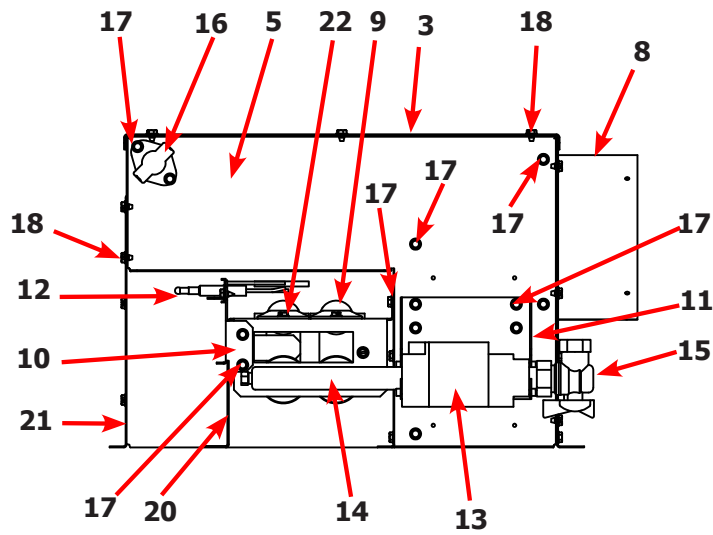

Dryer Burner Housing Group 80Lb

Key	Description	Part Number	Qty
	Housing Assembly, Burner	9803-212-001	1
1	Panel-Burner Housing, Front	9454-863-001	1
2	Panel-Burner Housing, Side Right	9454-861-001	1
3	Panel-Burner Housing, Side Left	9454-862-001	1
4	Panel-Burner Housing, Back	9454-864-001	1
5	Baffle-Burner Housing, Center	9049-098-001	1
6	Panel-Burner Housing, Top	9454-977-001	1
7	Panel-Burner Housing, Top	9074-343-001	1
8	Baffle-Burner Housing, Extention	9049-118-001	1
9	Duct Adaptor, 6"x1.25" long	9109-120-002	1
11	Side-Extention Baffle, Burner Housing	9551-069-001	2
12	Bracket-Support, Burner	9029-213-001	1
13	Burner, Main	9048-021-001	4
14	Screw, 10T-32x1/2	9545-008-008	4
15	Electrode-Ignition	9875-002-003	1
16	Cover-Burner, Intet	9074-344-001	1
17	Bracket-Support, Gas Valve	9029-234-001	1
18	Control Assy,Gas Valve, White Rodgers 36J	9857-193-001	1
19	Bracket-support, Gas Valve Left hand	9029-235-001	4
21	Manifold Assy	9381-014-001	1
22	Orfice-Natural, #29	9425-069-021	3
*	Orfice-LP, #46	9425-069-022	3
*	Kit, LP Conversion, White Rodgers	9732-102-023	1
23	Thermostat-HI-Limit	9576-203-002	1
24	Spacer-1/4x5/8 long	9538-166-009	2
25	Screw-8Bx1	9545-045-013	2
26	Screw, 10Bx1/4	9545-008-001	22
27	Screw, 10ABx3/8	9545-008-024	25
28	Sensor-temp(thermistr),10k,wht	9501-004-004	1
29	Bracket-mtg,ohpsensor	9029-315-001	1
*	Screw-hxwshrndrcuthd,10abx3/8	9545-008-024	3
*	Screw-rdhdc,8bx1/4	9545-045-005	1
*	Nut-wireconn,#71b,blk	8640-276-005	2

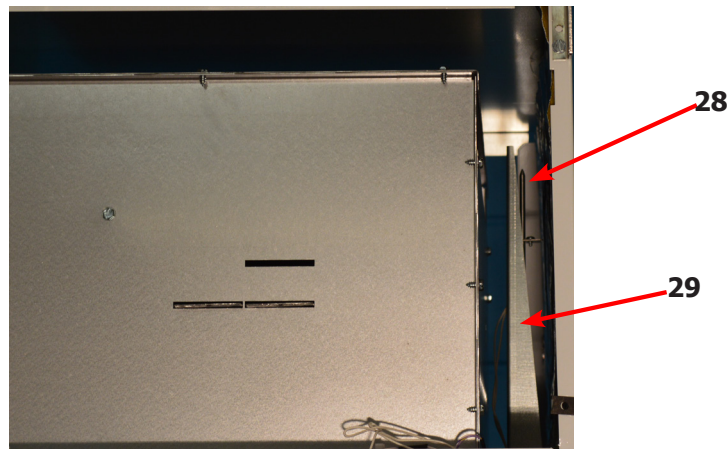

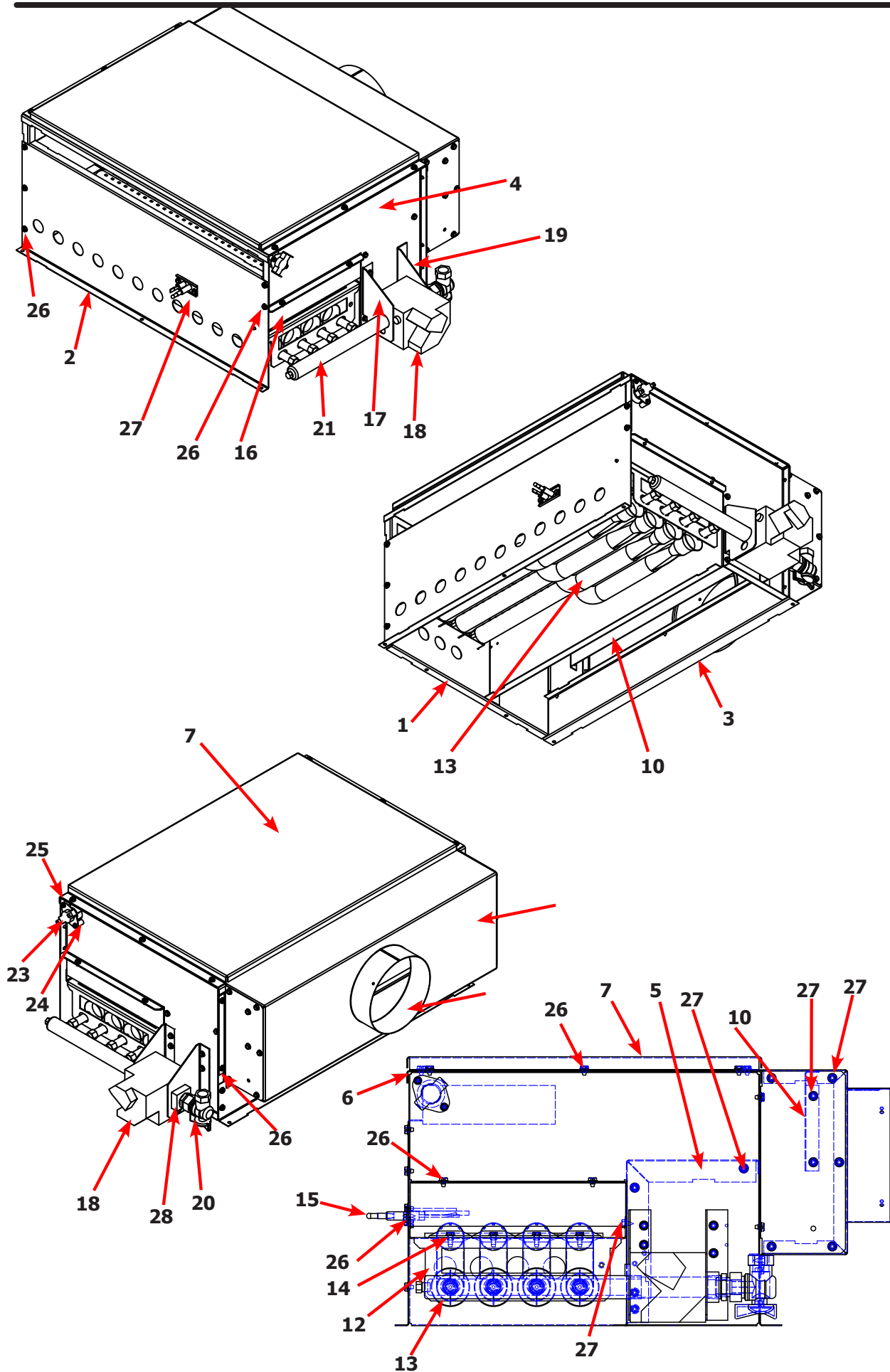

Electrical Box / Ignition Control

Key	Description	T-30	T-50	T-80	QTY
*	Control assembly opl	9857-240-001	9857-240-001	9857-240-003	
1	Wrapper-control box,	9636-203-001	9636-203-001	9636-203-001	1
2	Terminal blockasy-power,4pole	9897-035-001	9897-035-001	9897-035-001	1
*	Strip-marker,terminal	9558-029-003	9558-029-003	9558-029-003	1
*	Screw-hxwshrhdndct,#10bx1/2	9545-008-026	9545-008-026	9545-008-026	2
3	Transformer-control,w/circuit	8711-007-002	8711-007-002	8711-007-002	1
4	Relay-motor,30amp,24vac	5192-299-002	5192-299-002	5192-299-002	1
*	Screw-hxwshrndrcuthd,10abx3/8	9545-008-024	9545-008-024	9545-008-024	4
5	Relay	5192-285-004	5192-285-004	5192-285-004	1
*	Screw-hxwshdsl,6bx3/8	9545-031-003	9545-031-003	9545-031-003	2
6	Standoff-wiresaddle/arrowhead	9527-007-001	9527-007-001	9527-007-001	9
7	Controls assy-ignition	9857-182-001	9857-182-001	9857-182-001	1
*	Screw-hxwshrhdsl,8bx3/4	9545-045-007	9545-045-007	9545-045-007	2
8	Terminal block assembly-power	9897-039-001	9897-039-001	9897-039-001	1
	Screw-hxwshdsl,6bx3/8	9545-031-003	9545-031-003	9545-031-003	1
9	Terminal block assembly-power	9897-026-002	9897-026-002	9897-026-002	1
*	Screw-panhdr,#8abx1/2	9545-045-012	9545-045-012	9545-045-012	2
10	Terminal blockasy-injector,7pos	9897-032-002	9897-032-002	9897-032-002	1
*	Screw-pnhdr,6abx3/4	9545-031-010	9545-031-010	9545-031-010	2
11	Elecperiph-power supply,12v	9150-054-001	9150-054-001	9150-054-001	1
*	Screw-pnhdr,6abx3/4	9545-031-010	9545-031-010	9545-031-010	2
12	Elecperiph-power supply,24vdc	9150-057-001	9150-057-001	9150-057-001	1
*	Screw-pnhdrsems,#4-40x3/16	9545-020-009	9545-020-009	9545-020-009	2
*	Wireasy-jumper,blk/brn,15"	8220-113-006	8220-113-006	8220-113-006	1
*	Wireassy-jumper,blk/org,15"	8220-113-007	8220-113-007	8220-113-007	1
*	Wireasy-jumper,blk/brn,9-17	8220-147-003	8220-147-003	8220-147-003	1
*	Wireasy-jumper,blk/org,9-17	8220-147-004	8220-147-004	8220-147-004	1
*	Wireasy-blk/brn,15"	8220-146-011	8220-146-011	8220-146-011	1
*	Wireasy-blk/org,15"	8220-146-012	8220-146-012	8220-146-012	1
*	Wireasy-wht/org,14"	8220-063-046	8220-063-046	8220-063-046	1
*	Wireasy-wht/org,14"	8220-062-054	8220-062-054	8220-062-054	1
*	Wireasy-blk,17"	8220-078-027	8220-078-027	8220-078-027	2
13	Wiring harness-ignition control	9627-867-014	9627-867-014	9627-867-014	1
14	Wireasy-grn/yel,7"	8220-137-002	8220-137-002	8220-137-002	1
*	Screw-hxwshrhdsl,10-32ttx1/2grn	9545-008-027	9545-008-027	9545-008-027	1
*	Lock washer-exttooth,#10	8641-582-006	8641-582-006	8641-582-006	1
15	Wireasy-high voltage,#7,29 1/4"	9631-403-009	9631-403-009	9631-403-009	1
16	Bracket-control box,	9029-294-001	9029-294-001		2
*	Bracket-control			9029-254-001	2
*	Screw-hxwshrndrcuthd,10abx3/8	9545-008-024	9545-008-024	9545-008-024	6
17	Wire Bushing	9053-067-002	9053-067-002	9053-067-002	6

Electrical Box / Ignition Control

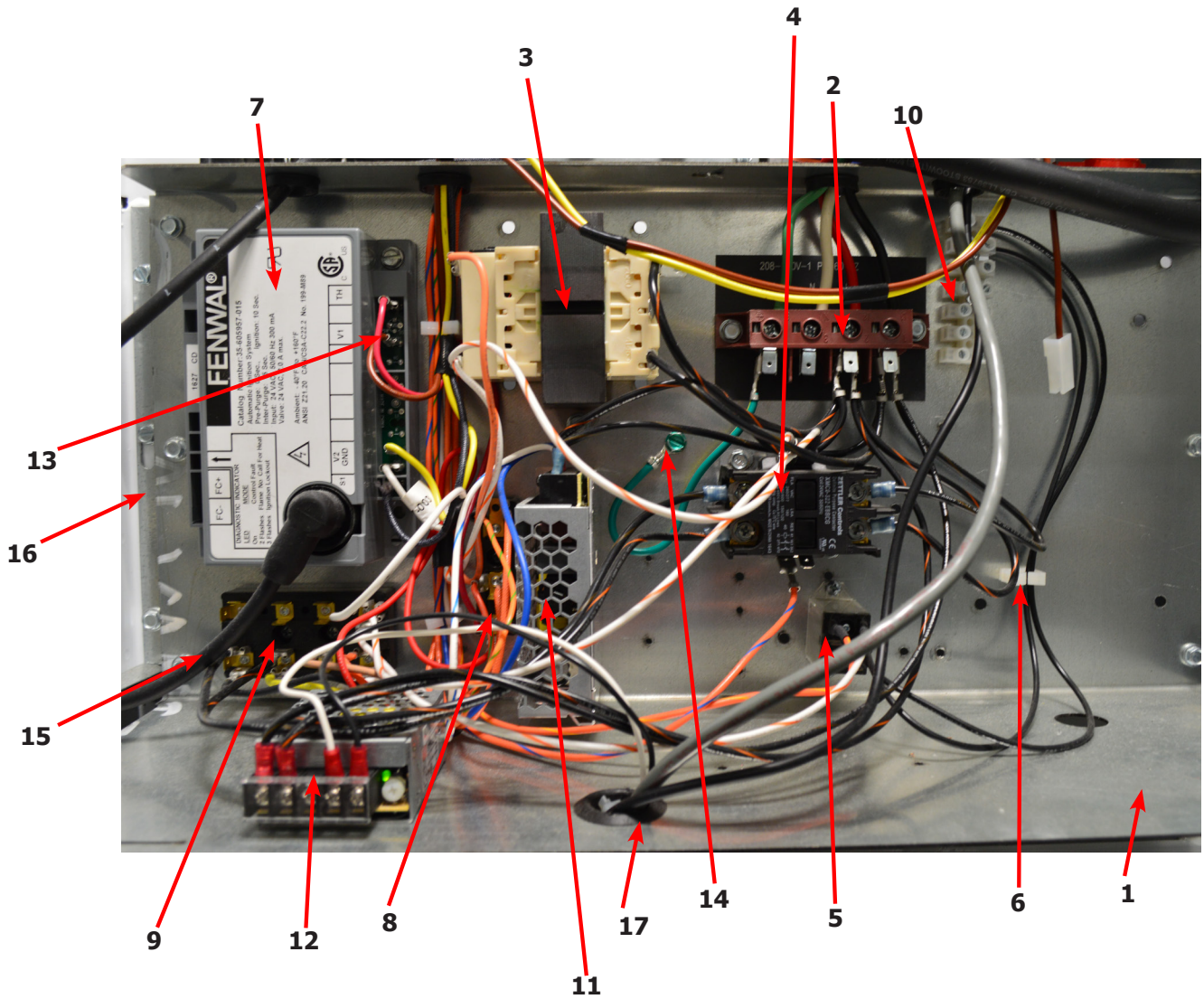

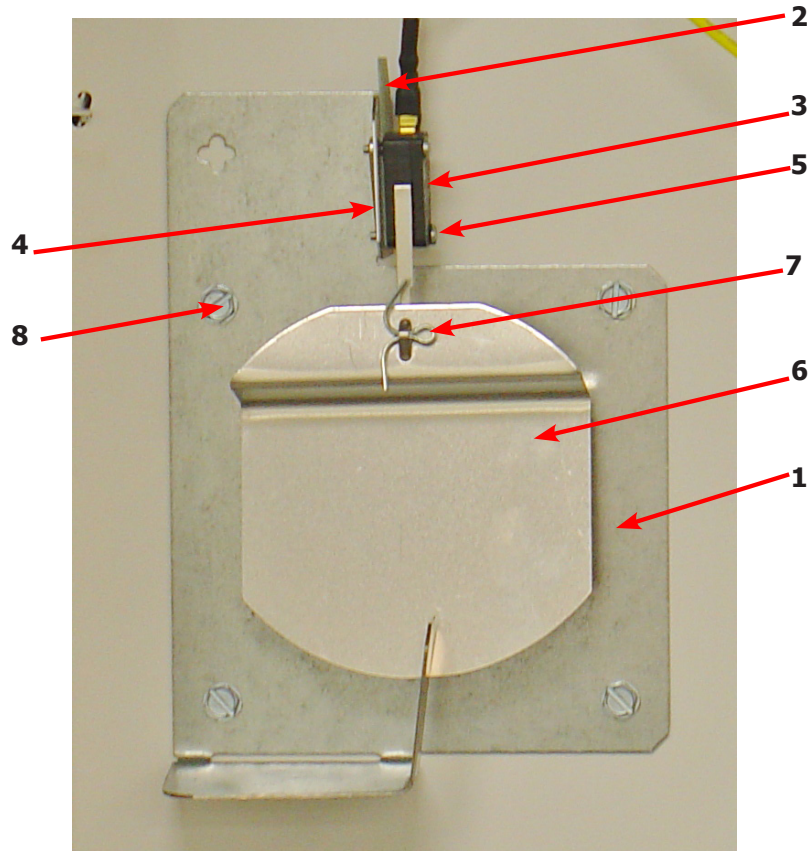

Key	Description	T-30	T-50	T-80	QTY
*	Air Flow switch Assy	9801-095-001	9801-098-002	9801-098-002	1
1	Bracket-Airflow switch	9029-174-001	9029-200-002	9029-200-002	1
2	Shield-Switch	9550-169-003	9550-169-003	9550-169-003	1
3	Switch-Micro	9539-461-009	9539-461-009	9539-461-009	1
4	Nut-Twin, 4-40	8640-401-001	8640-401-001	8640-401-001	1
5	Screw-.625, 4-40	9545-020-001	9545-020-001	9545-020-001	2
6	Actuator-Air Flow Switch	9008-007-001	9008-007-001	9008-007-001	1
7	Pin-Cotter, .09375x.75	9451-169-002	9451-169-002	9451-169-002	1
8	Screw, 10Bx1/4	9545-008-001			3
8	Screw, 10Bx1/4		9545-008-001	9545-008-001	5

Wiring Diagram T-50 Dryer -15

CAUTION: LABEL ALL WIRES PRIOR TO DISCONNECTION WHEN SERVICING CONTROLS. WIRING ERRORS CAN CAUSE IMPROPER AND DANGEROUS OPERATION. VERIFY PROPER OPERATION AFTER SERVICING.
 ATTENTION: AU MOMENT DEL'ENTRETIEN DES COMMANDES, ETIQUETEZ TOUTS LES FILS AVANT DE LES DEBRANCHER. DES ERREURS DE CABLAGE PEUVENT ENTRAINER UN FONCTIONNEMENT INADEQUAT ET DANGEREUX. S'ASSURER QUE L'APPAREIL FONCTIONNE ADEQUATEMENT UNE FOIS L'ENTRETIEN TERMINE.

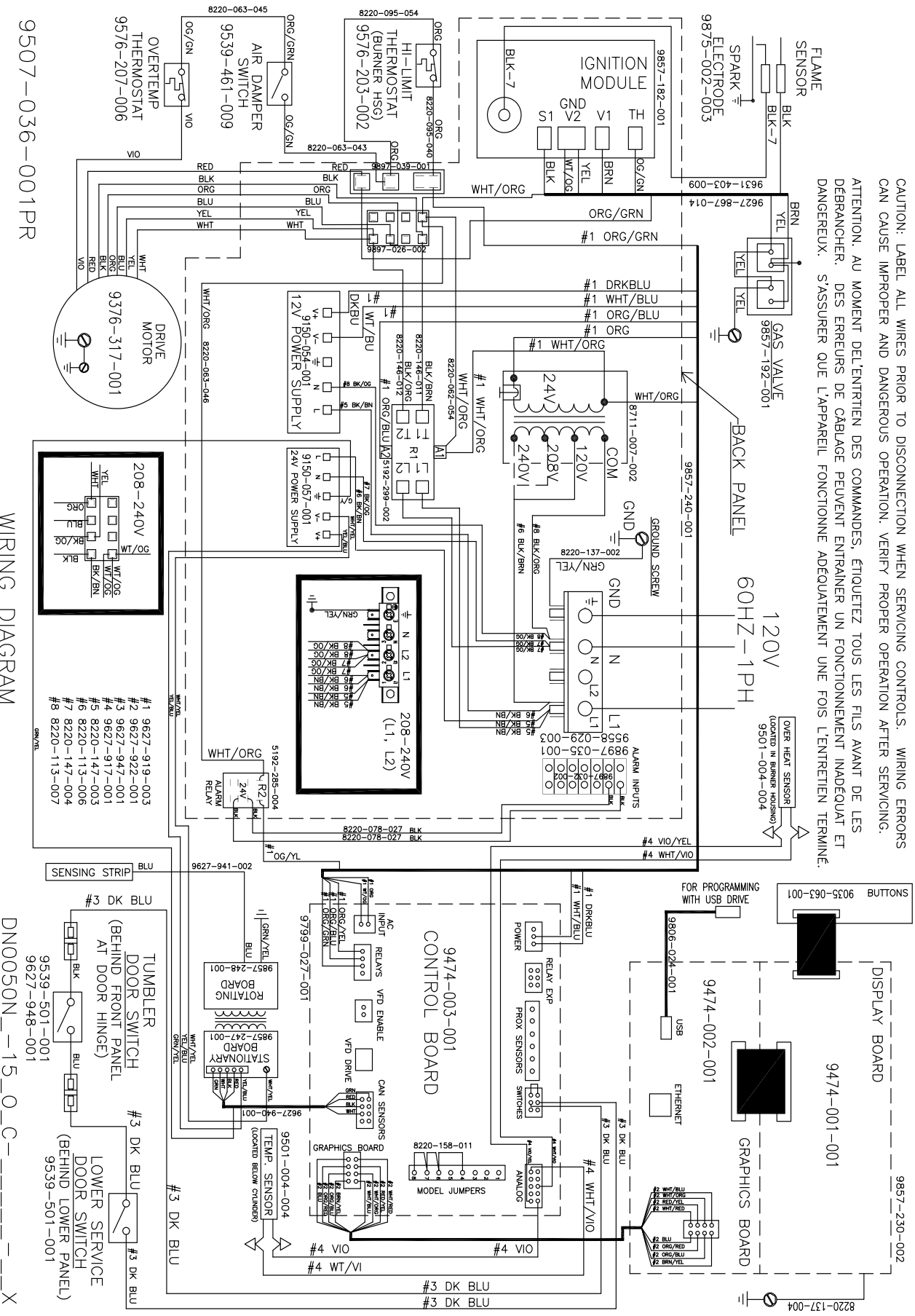

WIRING DIAGRAM

Wiring Diagram T-80 Dryer -15

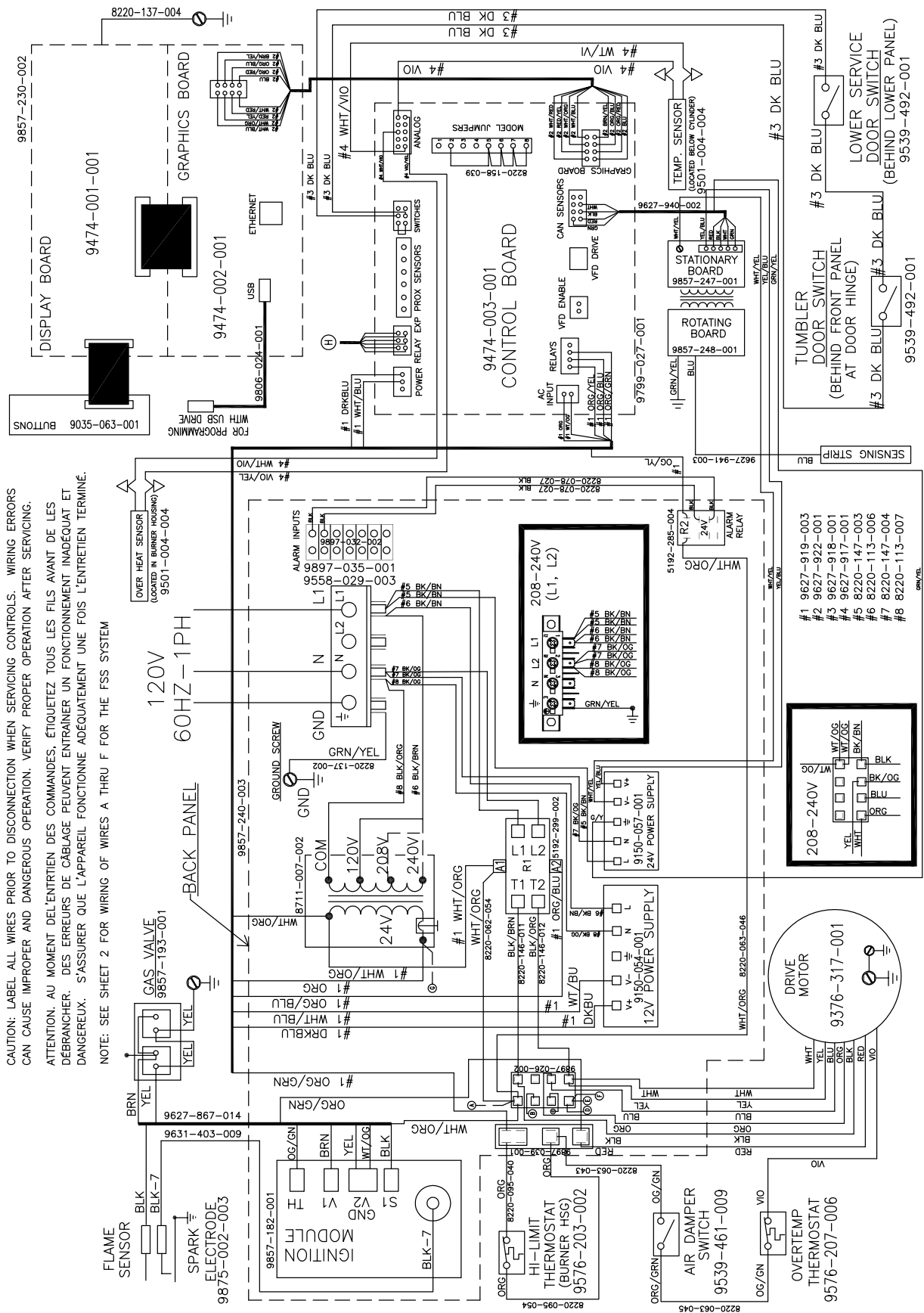

CAUTION: LABEL ALL WIRES PRIOR TO DISCONNECTION WHEN SERVICING CONTROLS. WIRING ERRORS CAN CAUSE IMPROPER AND DANGEROUS OPERATION. VERIFY PROPER OPERATION AFTER SERVICING.

ATTENTION: AU MOMENT DE L'ENTRIEN DES COMMANDES, ÉTIQUETEZ TOUS LES FILS AVANT DE LES DEBRANCHER. DES ERREURS DE CÂBLAGE PEUVENT ENTRAÎNER UN FONCTIONNEMENT INADÉQUAT ET DANGEREUX. S'ASSURER QUE L'APPAREIL FONCTIONNE ADÉQUATEMENT UNE FOIS L'ENTRETIEN TERMINÉ.

NOTE: SEE SHEET 2 FOR WIRING OF WIRES A THRU F FOR THE FSS SYSTEM

DN0080N_ -15_0_D_ _ _ _ X

WIRING DIAGRAM

9507-041-001PR

Optional Water Schematic

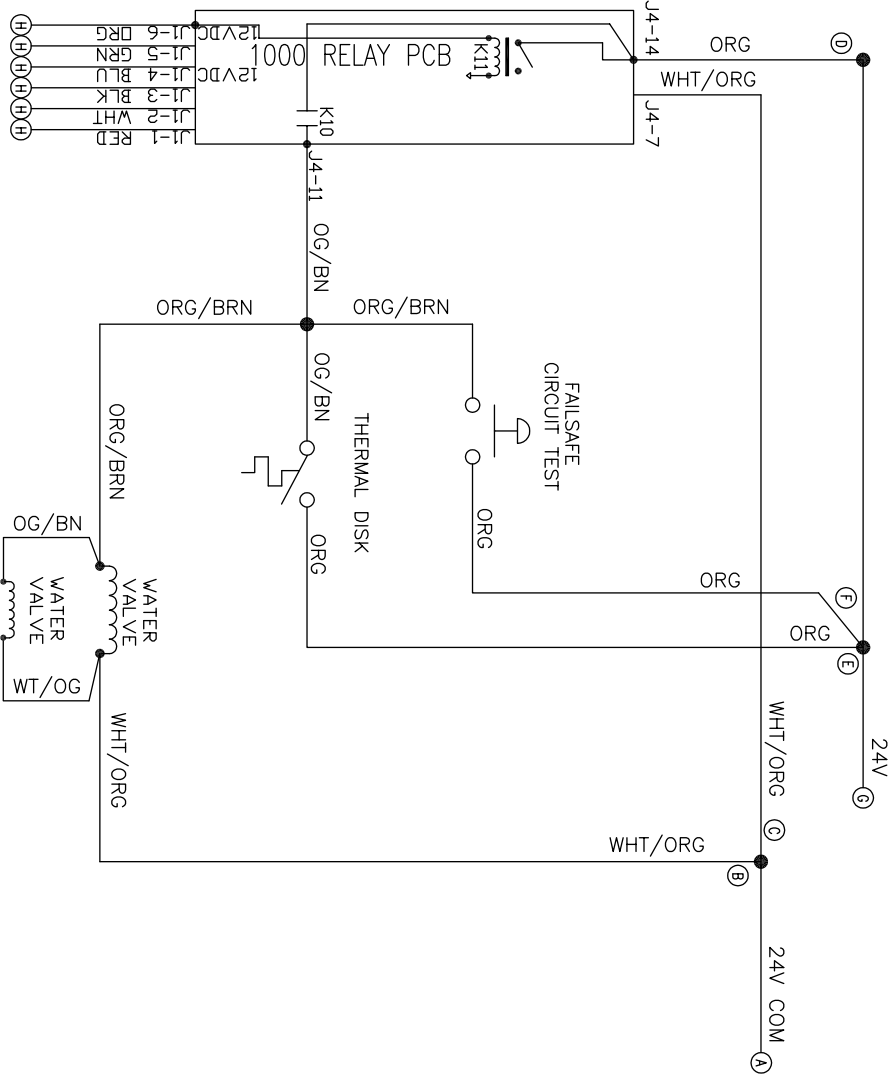

Optional Water Wiring Diagram

