



Section 6:

Parts Data
30# Stack



Cabinet Group - 30 lbs

Key	Part Number	Description	Quantity
*	9960-256-032	Door Assy., Loading Complete-Wht	2
*	9960-256-034	Door Assy., Loading Complete-SS	2
1	9960-255-008	Door Assy., Loading-SS(ring only)	2
2	9982-280-014	Plate Assy., Hinge (Wht) No Pin	2
2	9982-280-012	Plate Assy., Hinge (SS) No Pin.....	2
*	9545-012-015	Screw, Hinge to Door	8
*	8640-413-002	Nut, Hinge to Door	8
3	9212-002-003	Glass, Door	2
4	9206-413-001	Gasket, Glass (Black).....	2
*	9548-117-000	Support, Door Glass	2
5	9206-420-003	Gasket, Outer Rim (Black)	2
6	9244-082-001	Handle, Loading Door	2
*	9545-018-017	Screw, Handle 1/4-20 x 3/8	2
*	9531-033-001	Stud, Door Catch	2
*	8640-413-001	Nut, Hex	2
*	8640-413-003	Nut, Acorn	2
*	9086-015-002	Catch, Loading Door	2
*	8638-190-009	Pop Rivet for mtg. catch	4
*	8641-582-019	Lockwasher	4
*	8640-399-001	Spring Nut	6
7	9989-569-006	Panel Assy., Front- Lower (Wht)	1
7	9989-569-004	Panel Assy., Front- Lower (SS)	1
8	9989-568-006	Panel Assy., Front- Upper (Wht)	1
8	9989-568-004	Panel Assy., Front- Upper (SS)	1
9	9545-008-014	Screw, Phillips 10B x 1 3/4".....	14
9	8541-585-001	Washer finish	6
*	8640-399-001	Nut, Spring	12
10	9544-072-002	Strap, Hinge	2
*	9345-008-020	Screw, Hinge to Panel	8
11	9545-052-001	Screw, Door to Hinge Strap (Special Black Type)	2
*	8641-436-003	Washer, Fiber	2

Cabinet Group - 30 lbs (continued)

Key	Part Number	Description	Quantity
14	9141-175-002	Escutcheon, Upper	1
15	9435-026-001	Trim, Overlay-Upper (Blue).....	1
15	9435-034-001	Trim, Overlay-Upper (Black)	1
16	9141-176-002	Escutcheon, Lower	1
17	9435-020-001	Trim, Overlay-Lower (Blue).....	1
17	9435-028-001	Trim, Overlay-Lower Black)	1
18	9412-154-001	Nameplate Stack Dryer Express (Blue).....	.1
18	9412-167-001	Nameplate Stack Dryer Express (Black)1
21	8650-026-002	Lock, Thumb Turn	2
22	9857-187-001	Controls Assy, Electronic Mounted With Membrane Switch (Blue). 1	1
22	9857-187-003	Controls Assy, Electronic Mounted With Membrane Switch (Black) 1	1
22	9801-096-001	Membrane Switch Assy (Blue)	1
22	9801-105-001	Membrane Switch Assy (Black).....	1
23	8650-012-003	Lock and Key, Control #6324	1
24	9501-006-002	Sensor Temp Control.....	2
24	9486-137-002	Retainer - Push On.....	2
25	9866-004-010	Lint Drawer Assembly (Blue)	2
25	9866-004-013	Lint Drawer Assembly (Black).....	2
25	9435-003-009	Overlay trim, lint dwr, upper/lower (Blue)	1
25	9435-029-002	Overlay trim, lint dwr, upper/lower (Black).....	1
*	9545-020-009	Screw.....	10
*	9532-143-001	Felt Seal (back of lint screen assembly)	2
*	9181-036-001	Lint Screen Assembly ONLY (no front)	2
*	9555-057-002	Replaceable Lint Screen Only2
*	9095-044-001	Cam, Lock Lint Drawer2
*	9545-008-001	Lint Screen Strap Hold Down Screws 10Bx 1/4	32
*	9627-885-001	Harness, Electronic Control1
*	9095-044-001	Cam, Lock Control.....	1
*	6292-006-007	Key 6324 only for Computer.....	2
*	9627-886-001	Harness, Heat Sensor.....	1
*	9277-041-011	Insulation Cabinet Cover1
*	9209-037-002	Grommet, 3/16 ID	2
*	8544-006-001	Leg, Leveling 1/2"	4
*	9074-261-001	Cover, Cabinet (Top).....	1
*	9732-102-011	LP Kit for DDAD Dryers.....	1
*	9732-243-001	Stack Dryer Trunnion Puller.....	1
*	9555-057-003	Replaceable Lint Screen Fine Mesh Only1
*	9277-063-001	Insulation-Front Panel-Top Half	2
*	9277-063-002	Insulation-Front Panel-Lower Half.....	2
*	8640-276-002	Wire Nut Connector Grey.....	4
*	9527-007-002	Standoff Wire Saddle.....	8
*	9544-041-002	Strap - Bead Tie.....	1

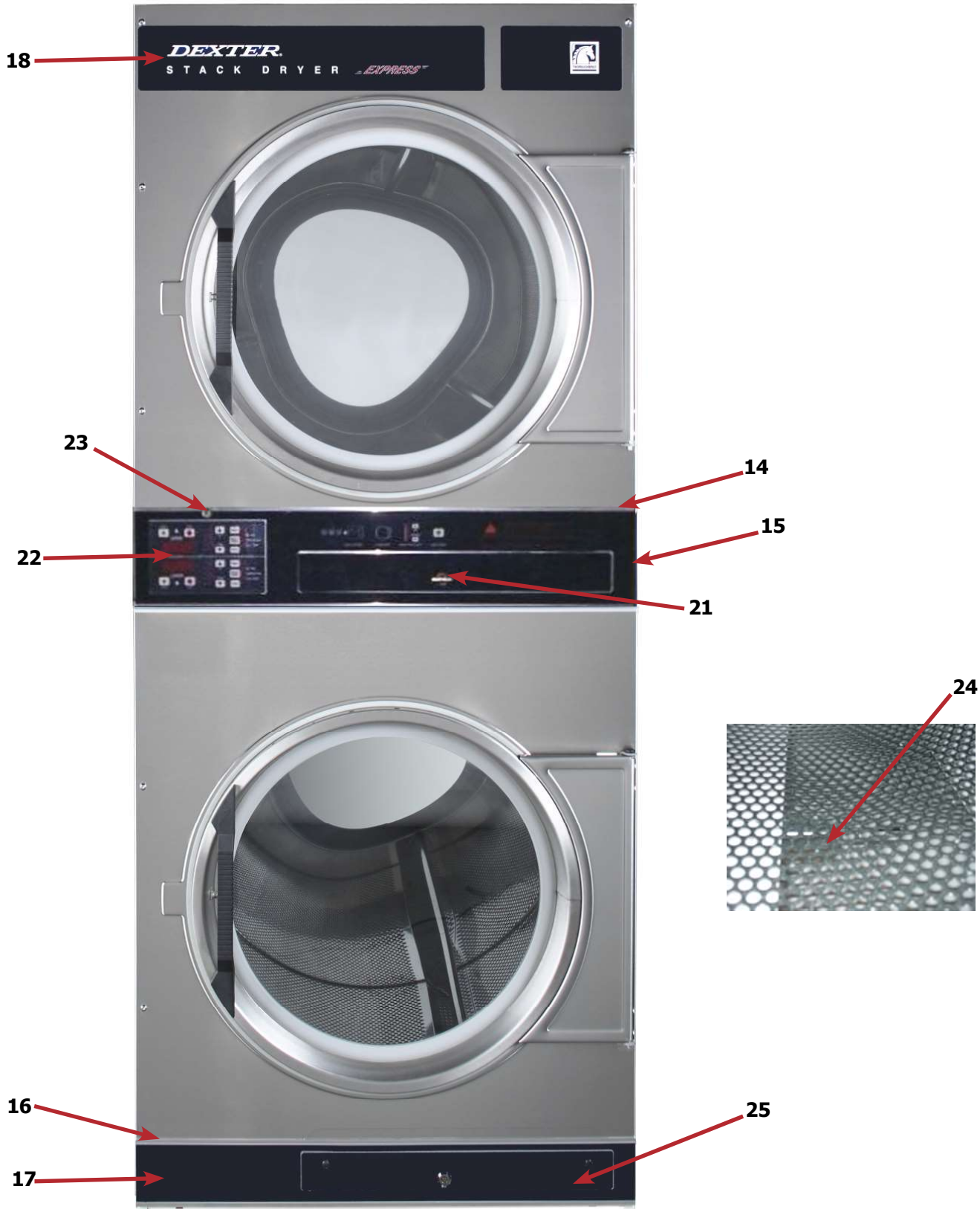

Door Switch Group - 30 lbs

Part Number
9539-487-001

Description
Door Switches2

Quantity



Hinge Plate Cover

1	9074-341-002	Cover-Hinge, Black.....	2
2	8636-018-001	Screw-TRHDCR, 10B x 3/8, Black.....	4

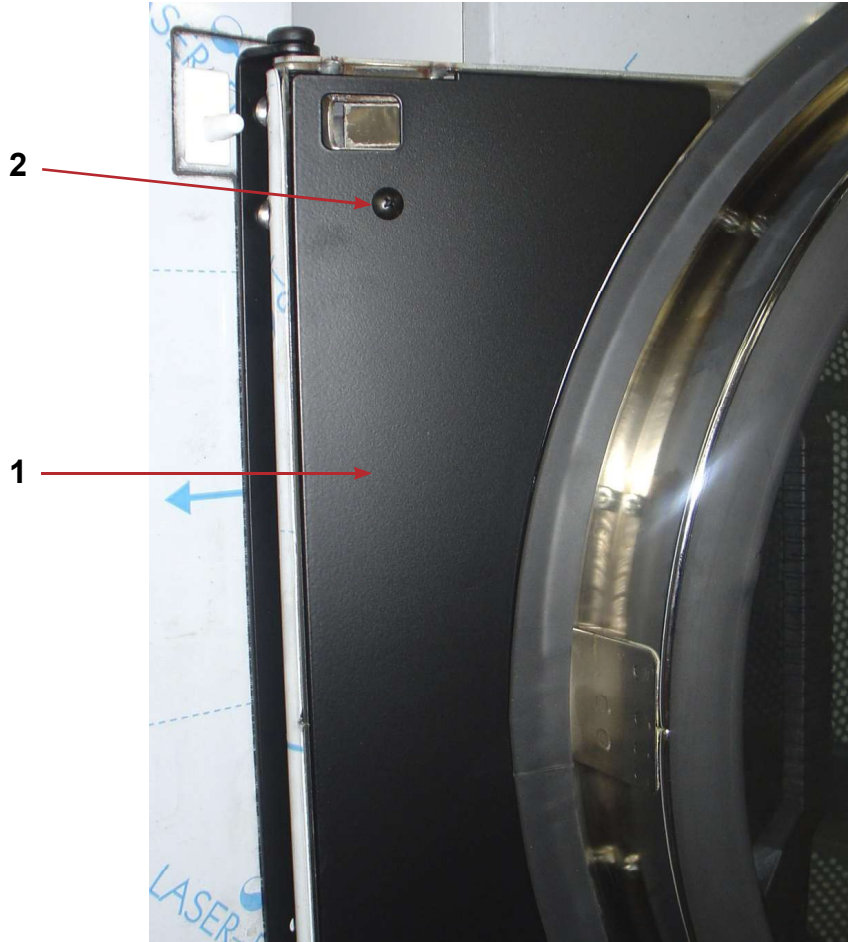

Bearing Housing Group

Key	Part Number	Description	Quantity
*	9803-160-003	Bearing Housing Complete Assy (Includes bearings & Spacer).....	1
1	9241-161-002	Housing, Bearing.....	1
*	9036-130-001	Bearing, Ball, Front	1
*	9538-139-002	Spacer, Bearing	1
2	9036-130-001	Bearing, Ball, Rear	1
3	9545-049-002	Screw-Wizlock, 3/8-24x3/4	4
4	8640-400-002	Nut, 5/16-18.....	4
5	9545-049-001	Screw, 3/8-24x1.....	2
6	8640-415-002	Nut, 3/8-24.....	2
*	9538-139-002	Shim, Tumbler	AR

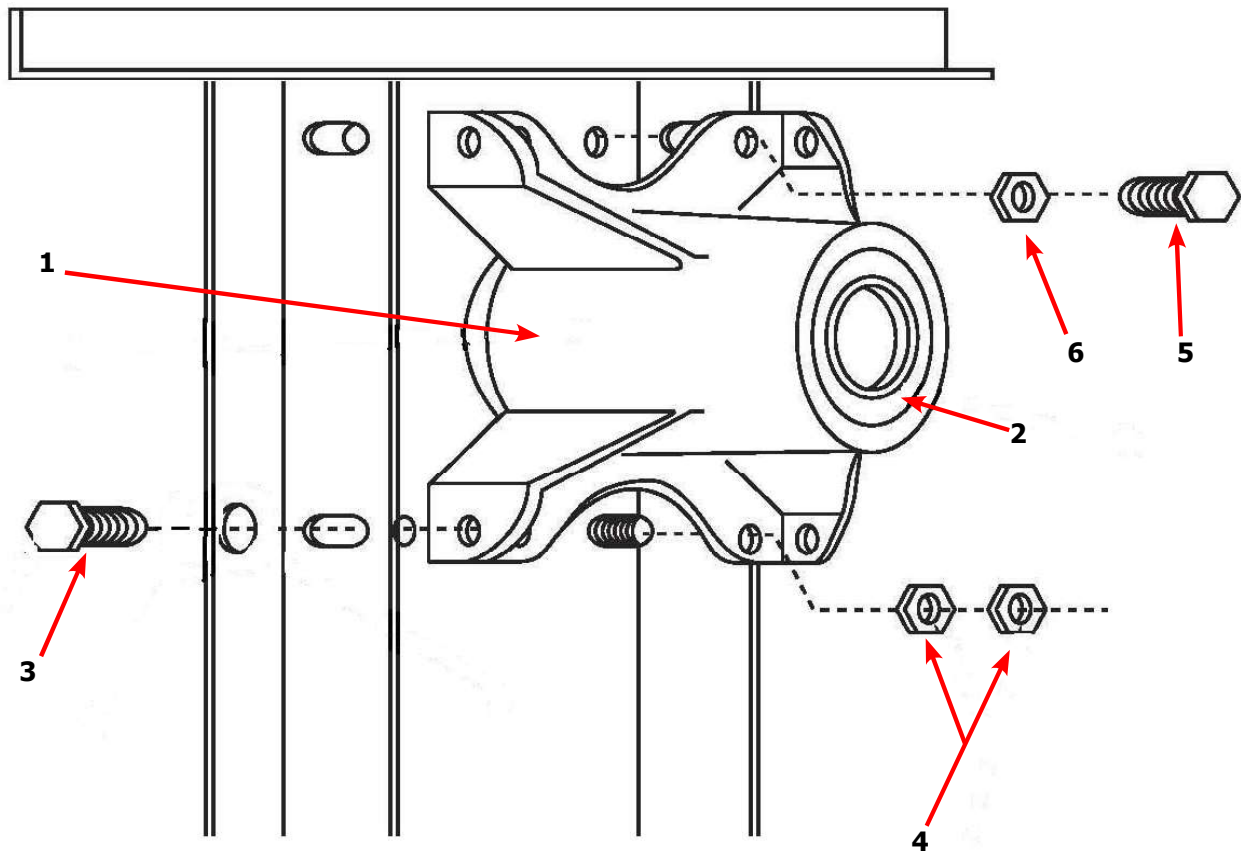

Tumbler Group

Key	Part Number	Description	Quantity
*	9848-147-001	Tumbler Assy Complete W/Spider (GALV).....	1
*	9848-147-002	Tumbler Assy Complete W/Spider (SS & Galv front)	1
1	9848-146-001	Tumbler Assy (Galvanized).....	1
1	9848-146-002	Tumbler Assy (Stainless Galvanized front)	1
2	9497-019-003	Rod, Tumbler	3
3	8641-554-001	Washer, Special.....	3
4	9552-013-000	Shim	AR
5	9568-015-001	Spider Assy.....	1
6	8640-415-004	Nut, Wiz Lock	3
7	9538-164-001	Spacer-Shaft.....	1
8	9487-234-005	Tolerance Ring	1
9	9908-049-002	Pulley, Driven.....	1
10	8641-581-026	Washer -Flat.....	1
11	8641-582-016	LockWasher - IntTooth, 1".....	1
12	9545-017-009	Screw, 1/2-13x1 1/4.....	1

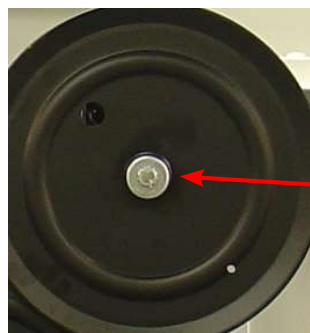
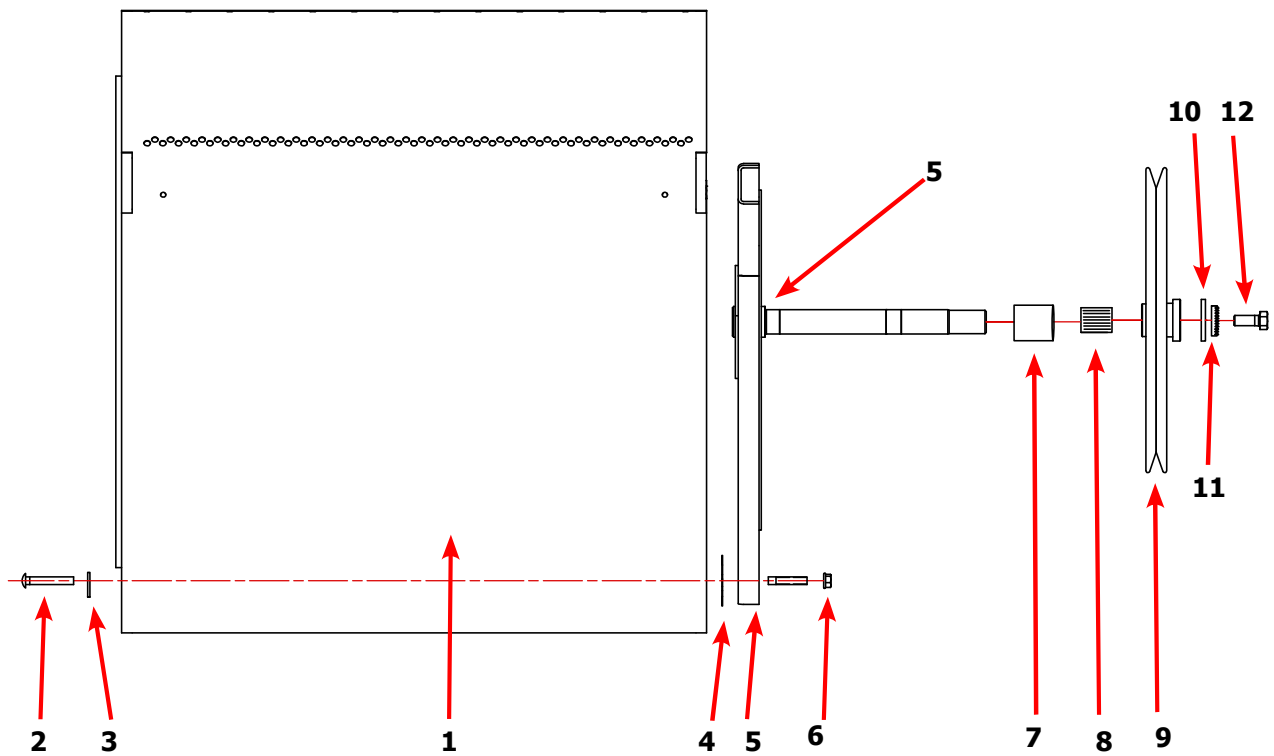

10, 11, 12

Burner Housing Group - 30 lbs

Key	Part Number	Description	Quantity
1a	9452-730-001	Service Burner Plate Front... ..	2
1	9452-729-001	Service Plate baffle Recirculation Chamber Clean Out	2
2	9545-008-001	Screw	16
18	9003-220-001	Angle, Burner Support	2
17	9048-020-001	Burner, Main	4
4	9545-008-001	Screw 10B x1/4"8
5	9875-002-003	Electrode Assy, Ignition	2
19	9545-045-001	Screw, Electrode Mtg 8B x 1/4"	4
7	9379-186-001	Valve, Gas Shut Off (Optional)	1
8	9857-192-001	Control Assy, Gas	2
9	9381-012-001	Manifold, Assy 2 Part 1 Piece	2
22	8615-104-038	Pipe Plug in end of Burner Manifold	2
11	9452-749-001	Plate Assy, Hi-Limit Stat Ignitor	2
12	9576-203-002	Thermostat, Hi-Limit	2
13	9074-329-001	Cover, Hi-Limit Stat Ignitor	2
15	9074-336-001	Cover, Safety Stat	2
16	9857-116-003	Control, Ignition Fenwall (3 trybox)	2
*	9803-229-001	Housing Assembly, Burner2
*	9545-008-006	Screw 10AB x 3/8"	4
*	9545-991-001	Panel, Back Burner Housing.....	2
*	9425-069-023	Orifice, Burner-Natural #125	4
*	9425-069-024	Orifice, Burner-LP #49.....	4
*	9039-915-001	Bracket, Gas Control	2
*	9545-008-006	Screw4
*	9538-142-001	Spacer, Hi-Limit	4
*	9545-045-007	Screw 8B x 3/4"	4
*	9545-008-006	Screw	6
*	9576-207-008	Thermostat, Safety Shutoff	2
*	9545-008-006	Screw	4
*	9545-008-006	Screw	4
*	9550-173-001	Shield, Burner Inlet1
*	9732-102-011	Kit, LP Conversion DDAD Kit2

^ Models built before 9/07

Burner Housing Group Photos - 30 lbs

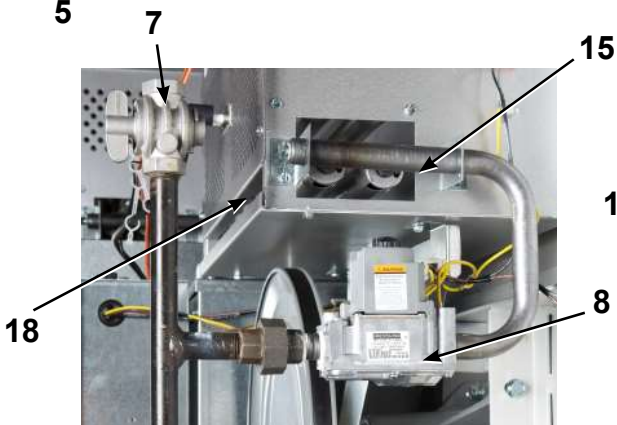
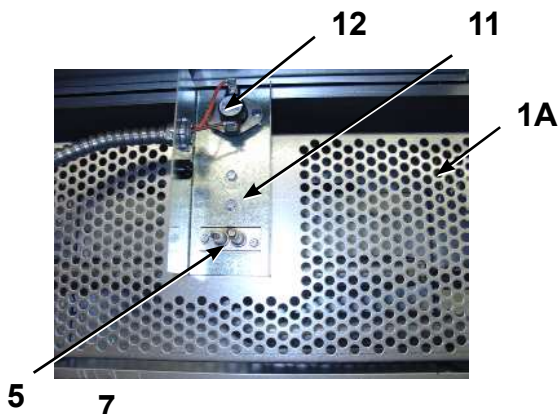
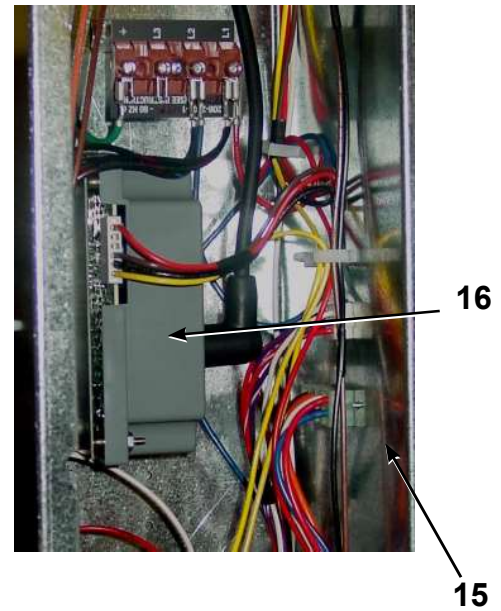
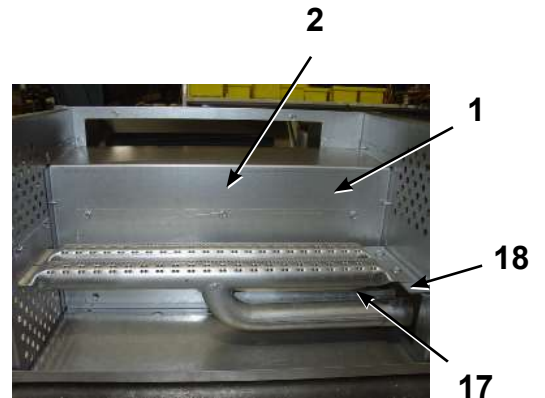
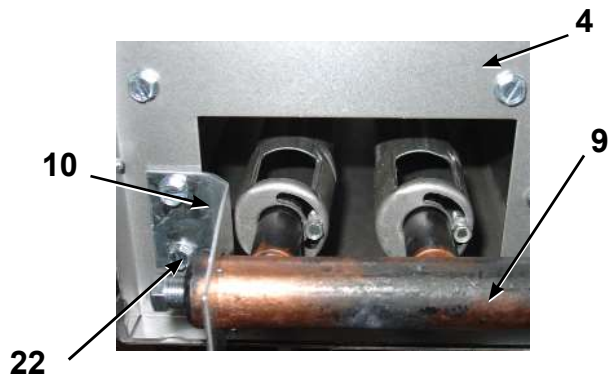

Rear View - 30 lbs

Key	Part Number	Description	Quantity
*	9627-861-001	Wire Harness Overtemperature Switch.....	2
*	9801-095-001	Switch Assy, Air Flow	2
1	9539-461-009	Switch, Air Flow.....	2
2	9029-174-001	Bracket, Switch- Air Flow	2
3	9008-007-001	Actuator, Switch	2
4	9451-169-002	Pin, Cotter	2
5	9545-020-001	Screw 4-40 x 5/8"	4
*	8640-401-001	Nut, Special Twin #4-40.....	2
*	9550-169-003	Shield, Switch.....	2
*	9545-008-001	Screw 10 Bx 1/4".....	6
7	9376-331-001	Motor, Drive 5hp	2
*	9732-202-026	Motor, Drive Kit.....	2
8	9452-740-001	Plate, Motor Mtg.....	2
*	9545-029-008	Bolt 3/8" - 16 x 3/4".....	8
*	8641-582-003	Lockwash Spring 3/8	8
9	9545-018-019	Screw, Motor Plate to Back Assy. 1/4-20x 2 1/2	8
9	86411-582-007	Lockwasher 1/4.....	8
9	9538-163-006	Spacer	8
9	8641-581-017	Flat Washer 1/4 x 7/8.....	24
9	9209-086-002	Rubber Grommet.....	8
*	9538-166-006	Grommet Spacers.....	8
*	9545-028-013	Screw, Set	4
10	9962-017-002	Back Assy, Blower Hsg.....	2
26	9278-039-001	Impeller, W/Set Screws.....	2
11	9991-053-001	Support Assy, Intermed. Pulley	2
12	9545-029-010	Bolt, Rd Hd 3/8-16 x 1 1/4.....	6
13	9545-029-003	Bolt, 3/8-16 x 1 1/2.....	2
12	8640-415-004	Nut Flange Wiziocok 3/8" - 16	6
12	8641-581-035	Washer, Flat.....	6
14	9861-022-001	Arm Assy-Tension, Complete	2
*	8641-581-035	Washer, Flat.....	2
15	9487-200-003	Ring-Retaining	6
16	9908-039-004	Pulley Assy, Intermediate with bronze flange bearing	2
*	9036-145-002	Bearing - Bronze Flange.....	4
17	9908-040-001	Pulley Driven.....	2
*	9306-006-000	Key Tumbler Shaft Woodcuff	2
*	8640-222-000	Nut Hex 1" - 14	2
*	8641-582-015	Washer Lock	2
*	9538-164-001	Spacer, Shaft	2
18	86A1-582-015	Washer, Lock	2
19	9040-077-001	Belt, Drive- Motor.....	2
20	9040-073-009	Belt, Drive- Tumbler	2
21	9534-319-002	Spring, Tension	2
22	9099-012-002	Chain, Tension.....	2
23	9248-022-002	Hook, Tension	2
*	9125-007-001	Damper Inside Duct Exhaust Upper	1
24	9451-146-001	Pin, Damper Hinge	2
*	8520-141-000	Nut, Spring	4
*	9425-007-002	Damper, Inside Duct Exhaust Lower	1
*	9545-008-026	Screw #10B x 1/2.....	6
25	9074-363-001	Cover Duct Upper.....	1
*	9074-364-001	Cover Duct Lower.....	1
*	9545-008-026	Screw 10ABx 1/2".....	14
25	9973-033-001	Heat Recirculation Assembly Duct.....	2
27	9453-157-001	Motor Pulley - Driver.....	1
*	9029-173-001	Bracket for Wire Harness Under Burner Housing.....	2
*	9545-008-024	Screw 10 AB x 3/8	58

Rear View Photos - 30 lbs

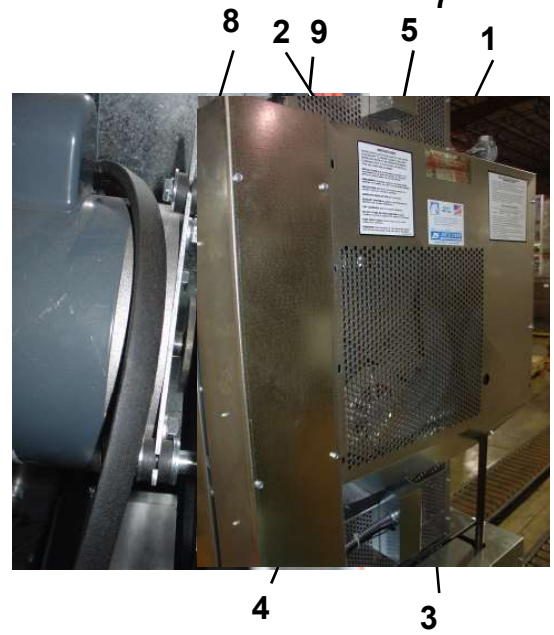
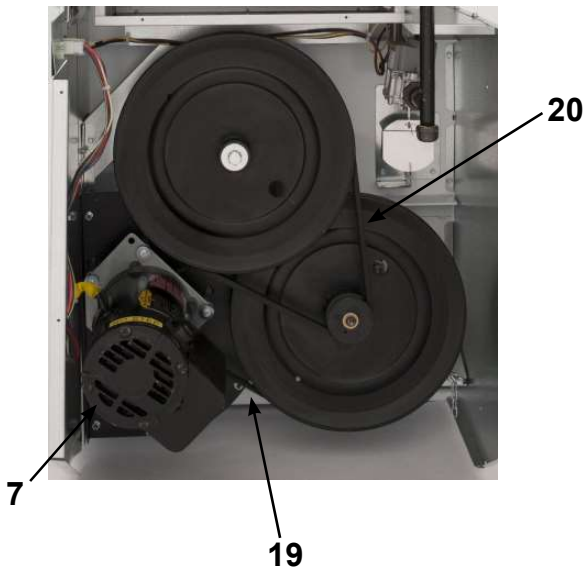
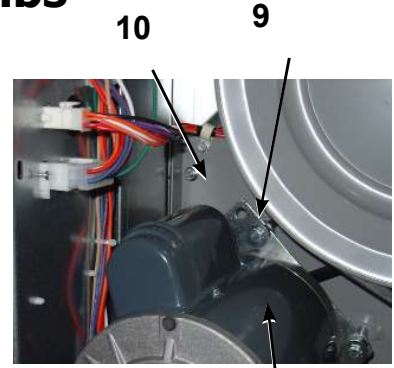
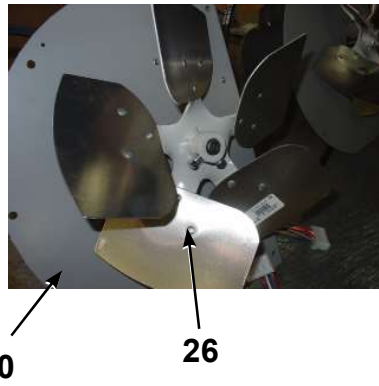
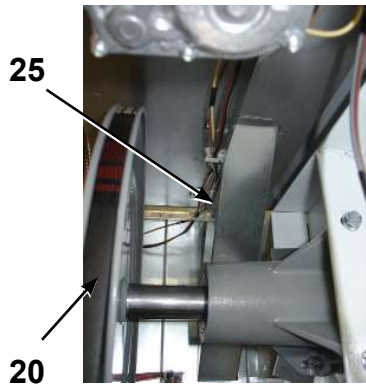

Rear Panel & Cover Group - 30 lbs

Key	Part Number	Description	Quantity
1	9208-083-001	Back Drive Guard Panel.....	2
*	9545-008-024	Screws, Guard.....	*
2	9208-076-001	Back Side Guard Panel Ass'y.....	2
3	9074-365-001	Cabinet (TOP COVER)	1
*	8544-006-001	Legs Leveling.....	4
5	9545-008-024	Screws 10 AB x 3/8	4
6	9577-062-001	Top Duct w/ Oval.....	1
4	9108-117-001	Electric Box Cover w/ Hinge.....	1
*	9545-008-024	Screws, Electronic Box Cover	3

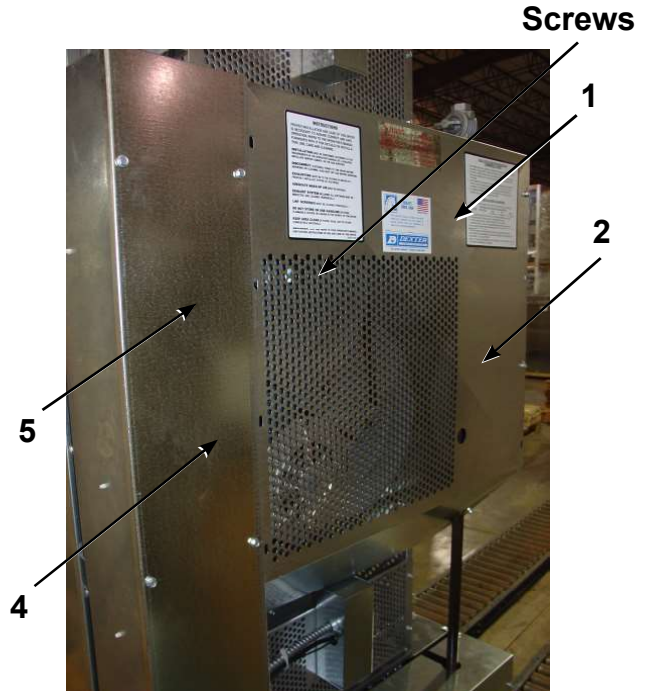
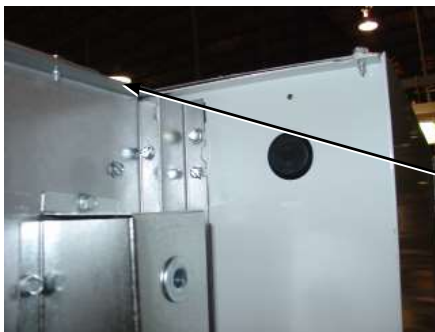

Screws

OPL Control Board - 30 lbs

Key	Part Number	Description	Quantity
1	9857-187-001	Control Assembly (Blue)	1
1	9857-187-003	Control Assembly (Black)	1
2	9471-017-001	PCB Control Board	1
3	9471-018-001	PCB Display Board	1
4	9500-007-001	Cable, Upper Control Long	1
5	9500-007-002	Cable, Lower Control Long	1
6	9801-096-001	Membrane Switch Assembly (Blue)	1
6	9412-167-001	Membrane Switch Assembly (Black).....	1
7	8636-024-001	Fuse, 600ma / 250v	2
*	9627-885-001	Harness Main Control OPL Stack Dryer	1

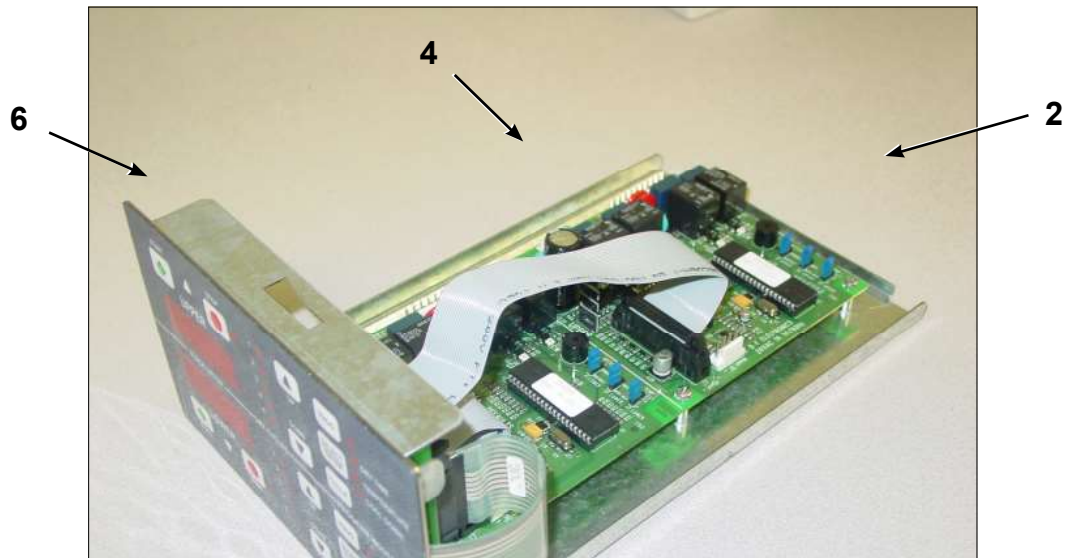
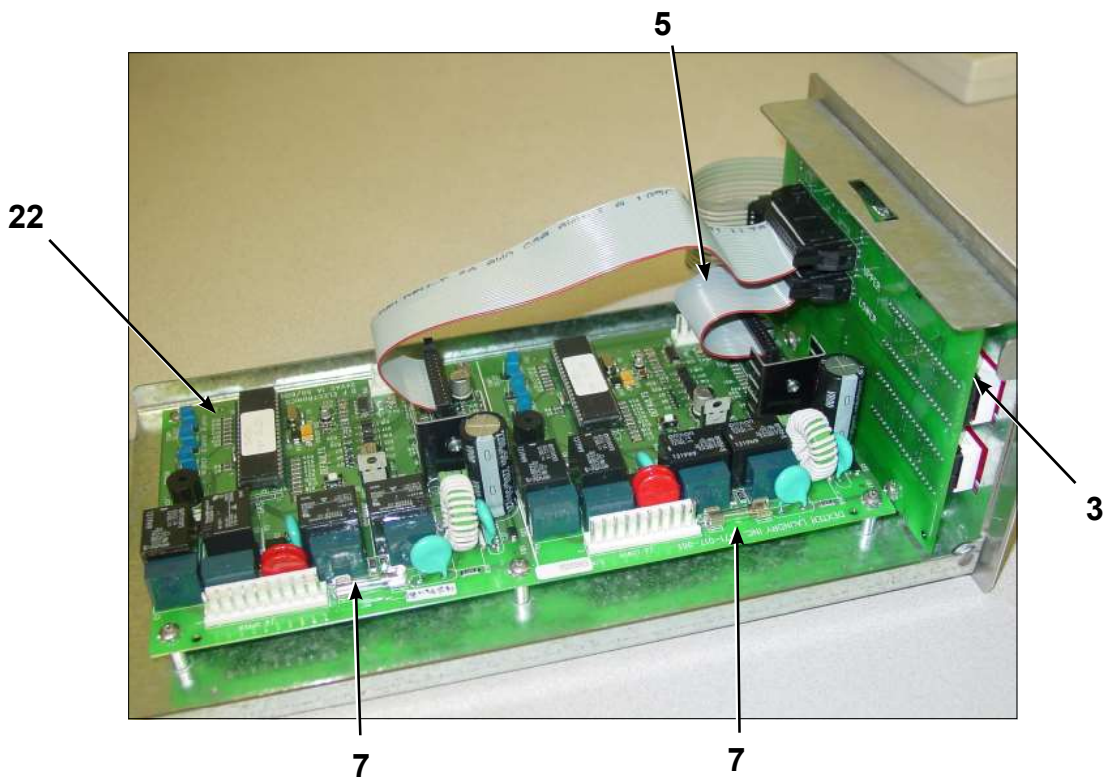

Control Assembly Group

Key	Part Number	Description	Quantity
*	9857-187-003	Control Assembly Complete (all below included)	1
*	9074-317-001	Control Box Cover	1
1	8653-068-003	Connector Conduit 3/8" STR.....	1
2	9558-029-003	Strip Terminal Marker (Behind Input Power) to above #3	1
3	9897-035-001	Terminal Block Assembly Main Power Inlet	1
*	9545-008-024	Screws 10AB x 3/8"	4
*	9627-859-003	Wire Harness - Power Main	1
4	8220-001-478	Wire Assembly Green 7"	1
5	9545-008-027	Screw # 10-32 x 12 Green	1
*	8641-582-006	Lockwasher Ext Tooth #10.....	1
6	9897-026-002	Terminal Block Main Power Middle	1
7	9897-026-001	Terminal Block.....	2
*	9545-045-012	Screw #8 ABx1 2 for terminal block.....	6
8	8711-013-001	Transformer Control.....	1
*	9545-008-024	Screws 10AB x 3/8"	4
9	9857-182-001	Ignition Control	2
*	9545-008-018	Screws 10AB x 3/4"	4
10	9631-403-009	Wire Assembly High Voltage Upper.....	1
11	9627-867-005	Wire Harness Ignition Control Upper.....	1
12	9631-403-008	Wire Assembly High Voltage Lower.....	1
13	9627-867-006	Wire Harness Ignition Control Lower.....	1
*	9053-067-002	Bushing Wire 7/8".....	4
14	9200-001-002	Fuseholder Assembly.....	3
*	8636-018-001	Fuse 1.5 Amp.....	2
*	8636-018-004	Fuse 2.5 Amp.....	1
15	5192-299-001	Relay Power.....	2
*	9545-045-012	Screws Power #8 AB x 1/2".....	4
*	8220-062-036	Wire Assembly Red/Black 14".....	1
*	8220-062-037	Wire Assembly Red/White 14".....	1
16	9627-864-006	Wire Harness Motor Extension.....	2
17	9527-007-001	Stand Off - Wire Saddle / Arrowhead	5
18	9627-863-001	Wire Harness Main Extension Access Under Burner Housing	4

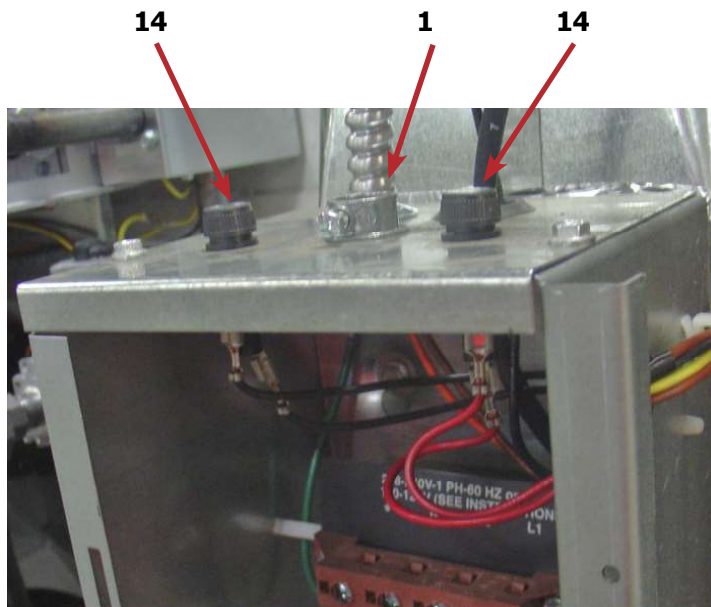

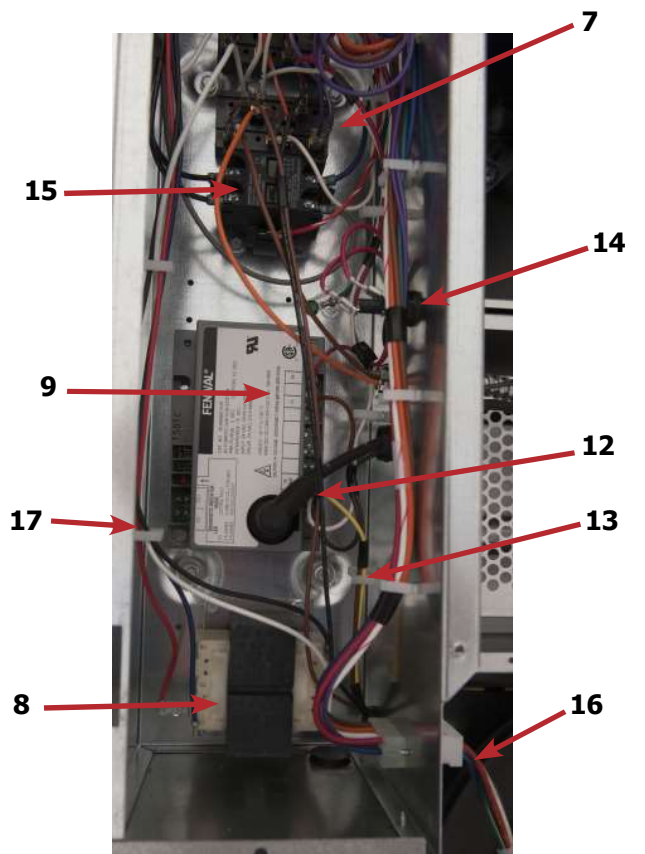
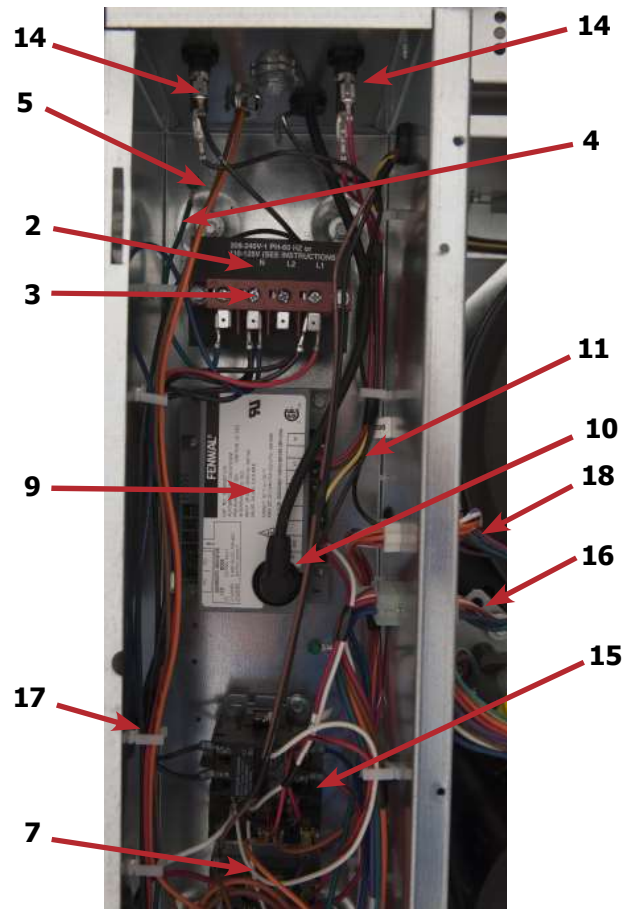
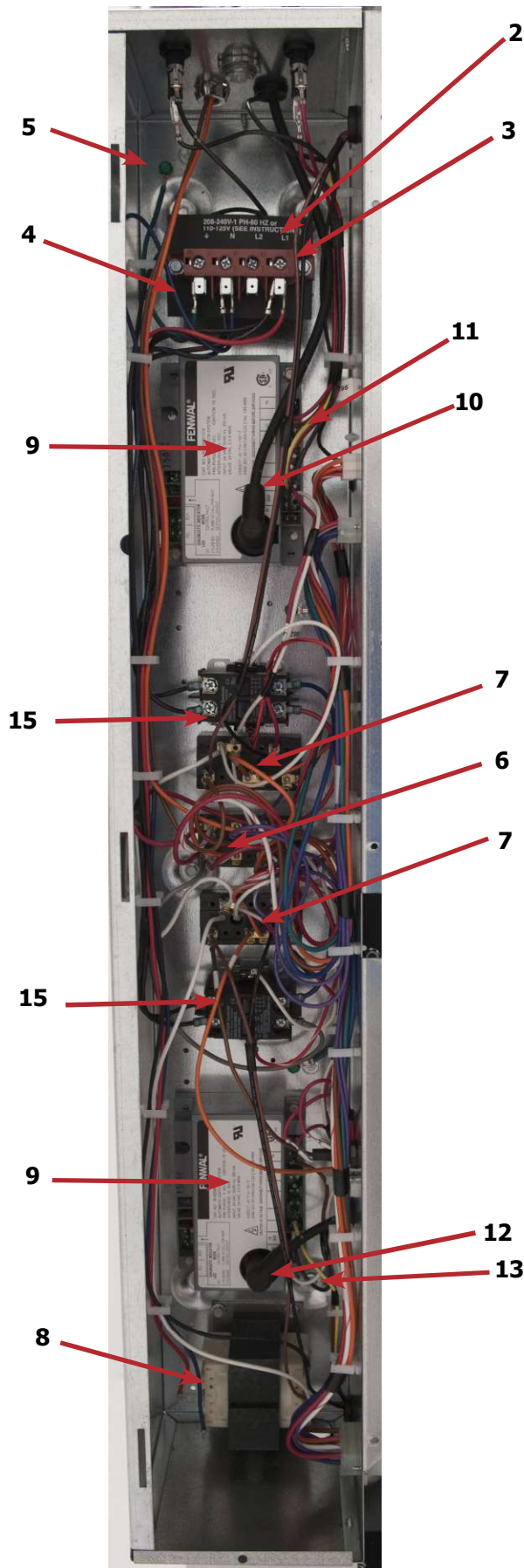

Wiring Group - 30 lbs

Key	Part Number	Description	Quantity
*	9627-859-003	Wiring Harness- Main Power	1
*	9631-403-008	Wire, Hi Voltage, Spark 18 1/2" Lower	1
*	9631-403-009	Wire High Voltage, Spark 29 1/4" Upper	1
*	8502-645-001	Label Instruction.....	1
*	9506-353-001	Wiring Label Schematic/Diagram.....	1
*	9627-867-005	Wire Harness Ignition Upper Low Voltage	1
*	9627-867-006	Wire Harness Ignition Lower Low Voltage	1
*	9627-887-001	Wire Harness Main Extension.....	1
*	9627-864-006	Wire Harness Motor Extension	2
*	8220-062-036	Wire Assembly Red/Black 14".....	1
*	8220-062-037	Wire Assembly Red/White 14".....	1
*	8220-062-038	Wire Assembly White 14".....	2
*	9627-861-001	Wire Harness - Overtemp / Airswitch	2
*	9627-885-001	Wire Harness Main Controller	1
*	9627-866-001	Wire Harness - Heat Sensor	1
*	8527-112-001	Decal Lighting and Clearance.....	1
*	8502-600-001	Label Warning & Notice.....	2
*	9506-651-001	Schematic Label	1
*	8514-259-001	Owners Manual.....	1
*	8507-330-001	Instruction Transient Voltage Suppressor	1
*	8507-350-001	Instructions Dryer Install / Start	1
*	8220-137-001	Wire Assembly Green 24"	1
*	8220-001-466	Wire Assembly Yellow 4 7/8" Gas Valve	2
*	8220-095-038	Wire Assembly Orange 48"	2
*	9506-651-001	Wiring Diagram.....	1
*	8220-095-040	Wire Assembly Orange 24"	1
*	8220-095-041	Wire Assembly Brown 24".....	1
*	9053-067-002	Bushings Wire 7/8".....	7
*	8220-095-039	Wire Assembly Brown 48"	1
*	9897-026-001	Terminal Block.....	2
*	9897-026-002	Terminal Block.....	2
*	9200-001-002	Fuse Holder.....	2
*	8636-018-001	Fuse 1.5 A.....	2
*	5192-298-002	Relay, Power 24 VAC	2
*	9897-035-001	Terminal Block Power 4 Pole	1
*	9558-029-003	Strip Marker, Terminal	1



Section 7:

Parts Data
50# Stack



Cabinet Group - 50lb

Key	Part Number	Description	Quantity
*	9960-285-002	Door Assy., Loading Complete-Wht	2
*	9960-285-001	Door Assy., Loading Complete-SS	2
1	9960-284-002	Door Assy., Loading-SS(ring only)	2
2	9982-353-002	Plate Assy., Hinge (Wht) No Pin	2
2	9982-353-001	Plate Assy., Hinge (SS) No Pin.....	2
*	9545-012-015	Screw, Hinge to Door	8
*	8640-413-002	Nut, Hinge to Door	8
3	9212-002-004	Glass, Door	2
4	9206-164-010	Gasket, Glass (Gray).....	2
4	9206-413-002	Gasket, Glass (Black).....	2
*	9548-117-000	Support, Door Glass	2
5	9206-420-004	Gasket, Outer Rim (Gray)	2
5	9206-420-005	Gasket, Outer Rim (Black)	2
6	9244-082-001	Handle, Loading Door	2
*	9545-018-017	Screw, Handle 1/4-20 x 3/8	2
*	9531-033-001	Stud, Door Catch	2
*	8640-413-001	Nut, Hex	2
*	8640-413-003	Nut, Acorn	2
*	9086-015-002	Catch, Loading Door	2
*	8638-190-009	Pop Rivet for mtg. catch	4
*	8641-582-006	Lockwasher	4
*	8640-399-001	Spring Nut	6
7	9989-517-011	Panel Assy., Front- Lower (Wht)	1
7	9989-517-009	Panel Assy., Front- Lower (SS)	1
8	9989-517-015	Panel Assy., Front- Upper (Wht)	1
8	9989-517-013	Panel Assy., Front- Upper (SS)	1
*	9277-054-001	Insulation Front Panel, half moon (top).....	2
*	9277-054-002	Insulation Front Panel, half moon (bottom).....	2
*	9545-008-014	Screw, FLHDCR, 10B x 1.....	14
*	8641-582-019	Lockwasher	8
*	8640-399-001	Nut, Spring	12
10	9544-069-002	Strap, Hinge (Wht)	2
10	9544-069-004	Strap, Hinge (SS/Gray)	2
*	9545-012-028	Screw, Hinge to Panel	8
11	9545-052-001	Screw, Door to Hinge Strap (Special Black Type)	2
*	8641-436-003	Washer, Fiber	2

Cabinet Group - 50lb (Continued)

Key	Part Number	Description	Quantity
14	9994-049-001	Escutcheon, Upper	1
15	9435-025-001	Trim, Overlay-Upper (Blue)	1
15	9435-033-001	Trim, Overlay-Upper (Black).....	1
16	9994-051-001	Escutcheon, Lower	1
17	9435-023-001	Trim, Overlay-Lower (Blue)	1
17	9435-031-002	Trim, Overlay-Lower (Black).....	1
*	9545-020-009	Screw	10
18	9412-154-002	Nameplate Stack Dryer Express (Blue).....	.1
18	9412-167-001	Nameplate Stack Dryer Express (Black)1
21	9866-007-002	Lint Drawer Assembly (Blue).....	2
21	9866-007-003	Lint Drawer Assembly (Black)	2
21	9435-024-001	Overlay Trim, Lint Drwr (Blue).....	1
21	9435-032-001	Overlay Trim, Lint Drwr (Black)	1
*	9532-143-001	Felt Seal (back of lint screen assembly)	2
*	9805-039-001	Lint Screen Assembly ONLY (no front)	2
*	9555-057-008	Replaceable Lint Screen Only2
24	8650-026-002	Lock and Key, Lint Drawer Thumb Turn	2
*	9505-043-001	Cam, Lock.....	.2
*	9545-008-001	Lint Screen Strap Hold Down Screws 10Bx 1/4	32
22	9857-187-001	Controls Assy, Electronic w/Membrane Switch (Blue)	1
22	9857-187-003	Controls Assy, Electronic w/Membrane Switch (Black)	1
22	9801-096-001	Membrane Switch Assy (Blue).....	1
22	9801-105-001	Membrane Switch Assy (Black)	1
*	9627-885-001	Harness, Electronic Control1
*	6292-006-007	Cam, Lock Control	1
*	9627-886-001	Harness, Heat Sensor1
*	9277-041-017	Insulation Cabinet Cover1
20	9501-004-004	Sensor Temp Control (10K Ohms).....	2
*	9545-045-005	Screw, Round Head (Mounts sensor; phillips head).....	2
*	9209-037-002	Grommet, 3/16 ID	2
*	8544-006-001	Leg, Leveling 1/2"	4
*	9074-320-001	Cover, Cabinet (Top)	1
*	9732-253-001	DDAD Kit for Dryers without Neutral and using 208-240 volt....	1
*	9732-102-013	LP Kit for DDAD Dryers 108K BTU	1
*	9732-243-001	Stack Dryer Trunnion Puller	1
*	9555-057-010	Replaceable Lint Screen Fine Mesh Only1
*	9277-054-001	Insulation-Front Panel-Top Half	2
*	9277-054-002	Insulation-Front Panel-Lower Half	2
*	9501-008-002	Bracket for Heat Sensor Mounting (Under Basket) with Sensor ..	2
*	8640-276-002	Wire Nut Connector Grey.....	4
*	9527-007-002	Standoff Wire Saddle	8
*	9544-041-002	Strap - Bead Tie	1

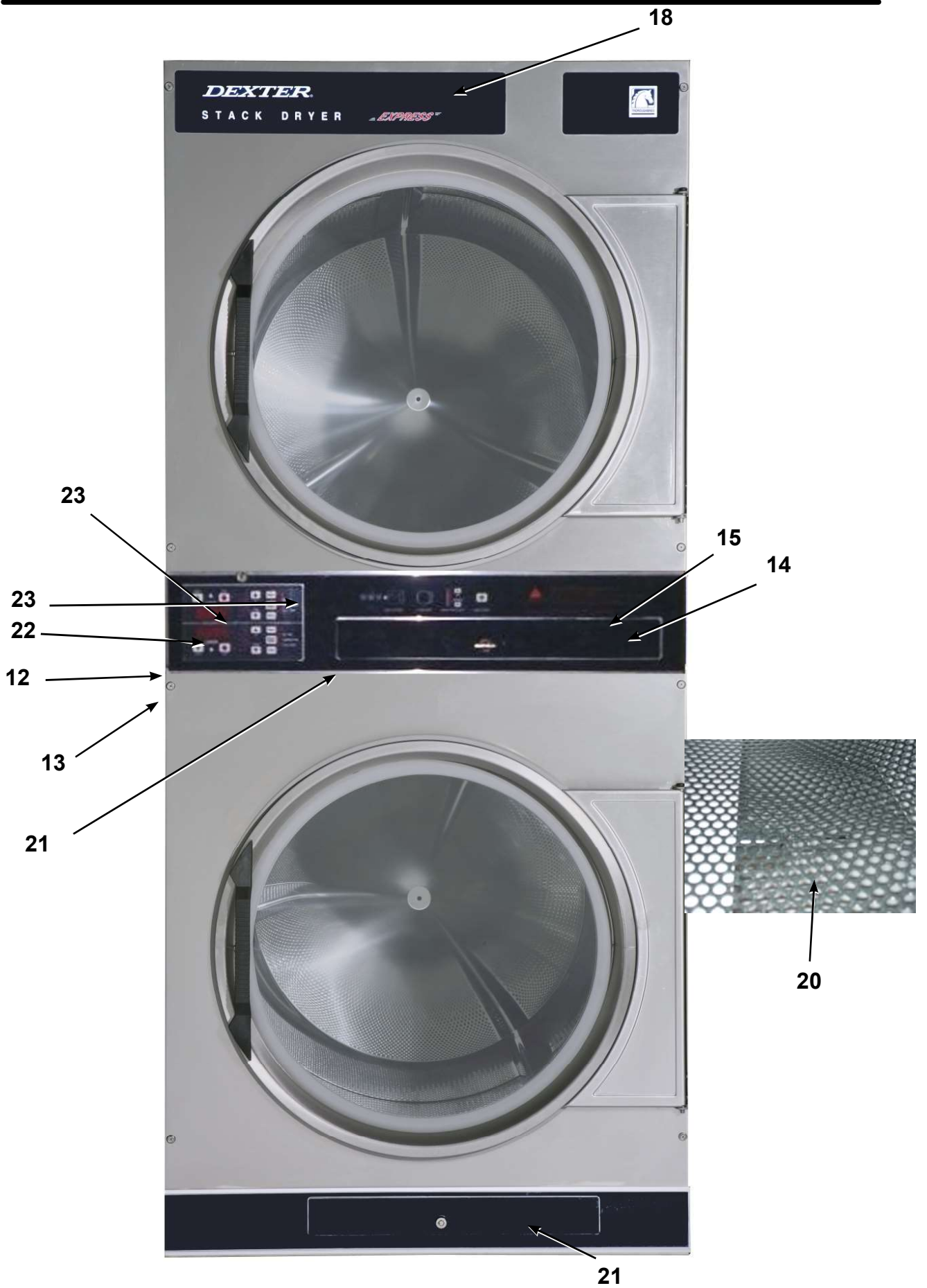

OPL Control Board

Key	Part Number	Description	Quantity
1	9857-187-001	Control Assembly (Blue)	1
1	9857-187-003	Control Assembly (Black)	1
2	9471-017-001	PCB Control Board	1
3	9471-018-001	PCB Display Board	1
4	9500-007-001	Cable, Upper Control Long	1
5	9500-007-002	Cable, Lower Control Long	1
6	9801-096-001	Membrane Switch Assembly (Blue)	1
6	9412-167-001	Membrane Switch Assembly (Black).....	1
7	8636-024-001	Fuse, 600ma / 250v	2
*	9627-885-001	Harness Main Control OPL Stack Dryer	1

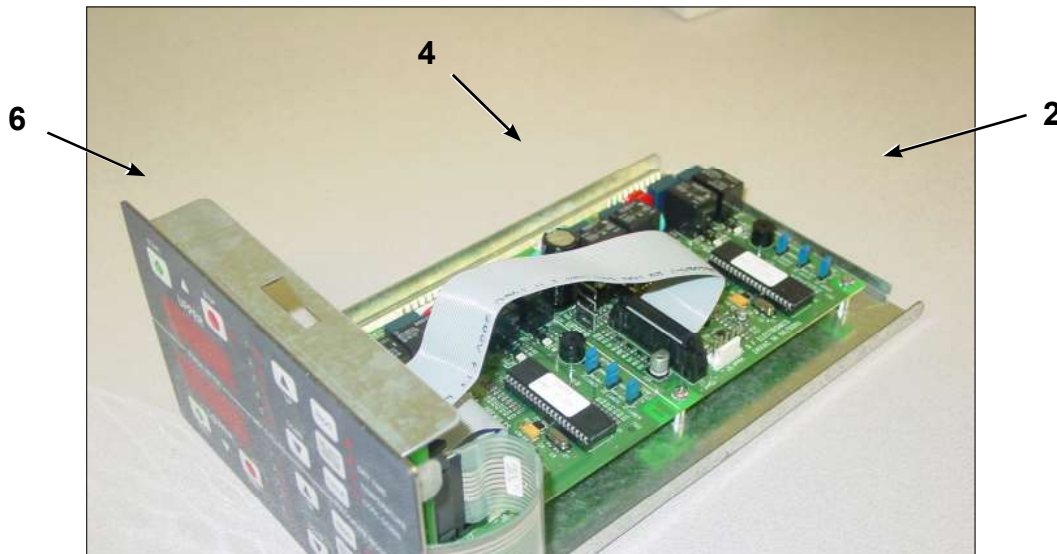
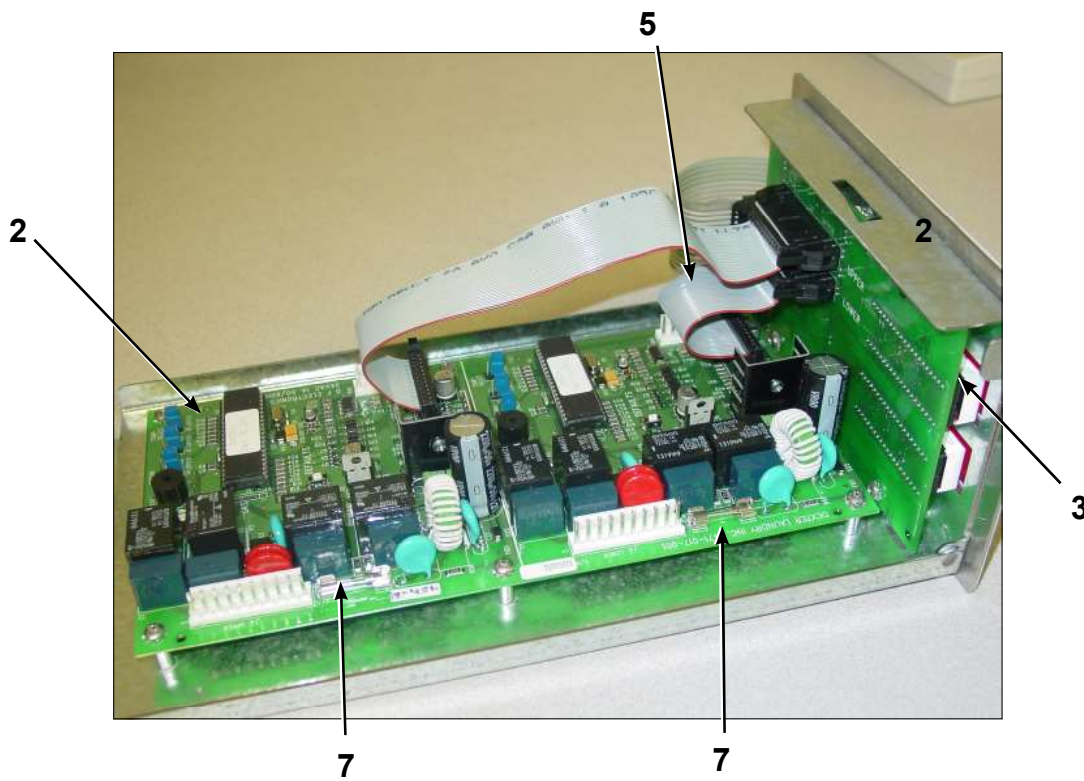

Bearing Housing Group

Key	Part Number	Description	Quantity
1	9241-189-002	Housing, Bearing	2
2	9036-159-003	Bearing, Ball Rear.....	2
*	9538-183-001	Spacer, Bearing	2
*	9036-159-001	Bearing, Ball Front.....	2
5	9545-017-017	Bolt, 1/2 x 3/4.....	8
7	8640-417-002	Nut, 1/2	8
*	9803-201-001	Bearing Housing Complete Ass'y (includes bearings,spacer)	2
4	9545-017-018	Screw 1/2 x 1 1/2	4

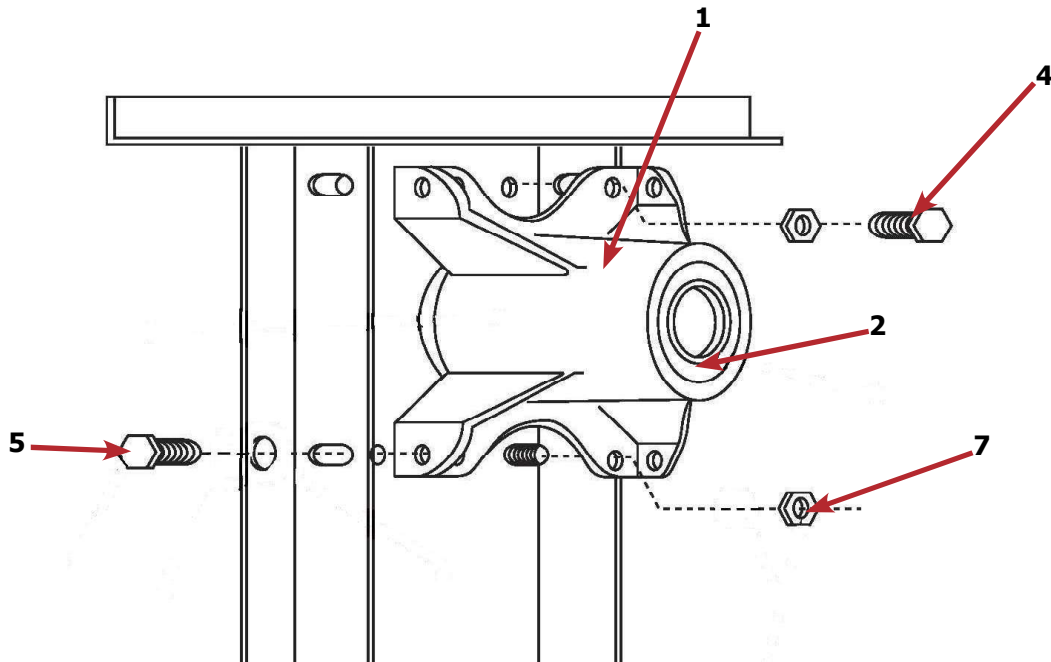

Burner Housing Group - 50lb

Key	Part Number	Description	Quantity
*	9803-230-001	Housing Assembly, Burner2
1a	9452-730-001	Service Burner Plate Front... ..	2
1	9452-850-001	Service Plate baffle Recirculation Chamber Clean Out	2
*	9545-008-006	Screws	8
2	9545-008-001	Screw	16
18	9003-220-001	Angle, Burner Support	2
*	9545-008-006	Screw4
17	9048-020-002	Burner, Main	4
*	9545-008-006	Screw 10AB x 3/8"	4
*	9454-992-001	Panel, Back Burner Housing.....	2
4	9545-008-001	Screw 10B x1/4"8
5	9875-002-003	Electrode Assy, Ignition	2
19	9545-045-001	Screw, Electrode Mtg 8B x 1/4".....	4
7	9379-186-001	Valve, Gas Shut Off (Optional)	1
8	9587-192-001	Control Assy, Gas	2
9	9381-012-001	Manifold, Assembly 2 Part 1 Piece	2
*	9425-069-021	Orifice, Burner-Natural #29.....	4
*	9425-069-022	Orifice, Burner-LP #46.....	4
10, 14	9029-175-001	Bracket, Manifold.....	.4
22	8615-104-038	Pipe Plug in end of Burner Manifold	2
*	9545-008-006	Screw4
12	9576-203-002	Thermostat, Hi-Limit	2
*	9538-142-001	Spacer, Hi-Limit	4
*	9545-045-007	Screw 8B x 3/4".....	4
13	9074-329-001	Cover, Hi-Limit Stat Ignitor	2
*	9545-008-006	Screw	6
*	9576-207-008	Thermostat, Safety Shutoff	2
*	9545-008-006	Screw	4
15	9825-062-001	Cover, Safety Stat	2
*	9545-008-006	Screw	4
16	9857-116-003	Control, Ignition Fenwall (3 trybox)	2
*	9732-102-013	Kit, LP Conversion DDAD Kit2
*	9838-018-003	Welded One Piece Gas Pipe Assembly	1

Burner Housing Group Photos - 50lb

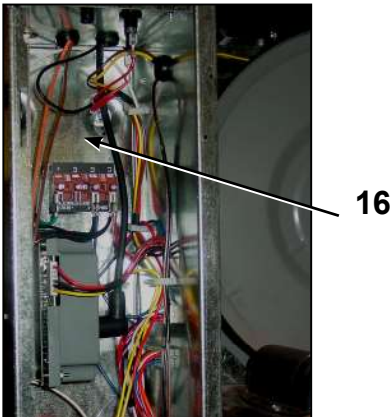
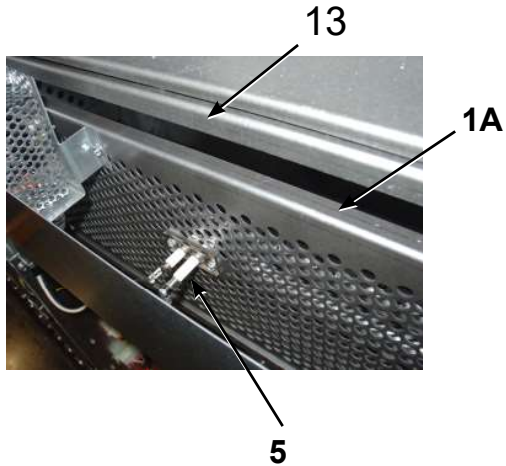
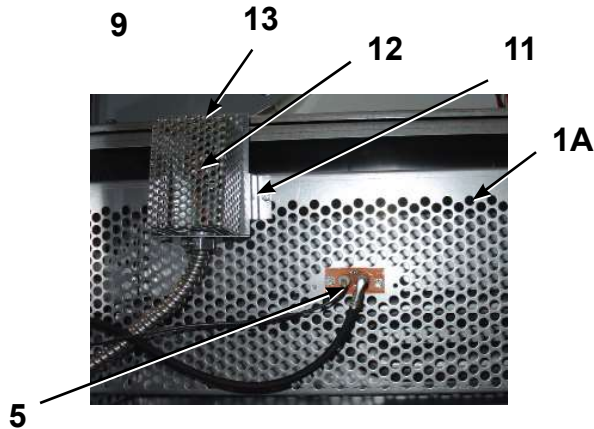
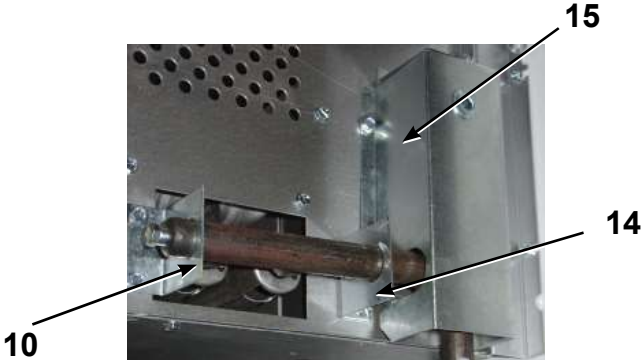
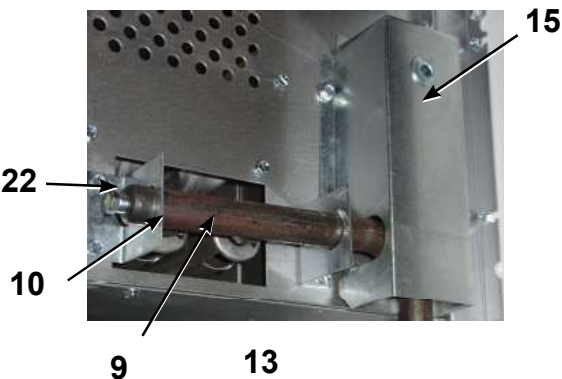
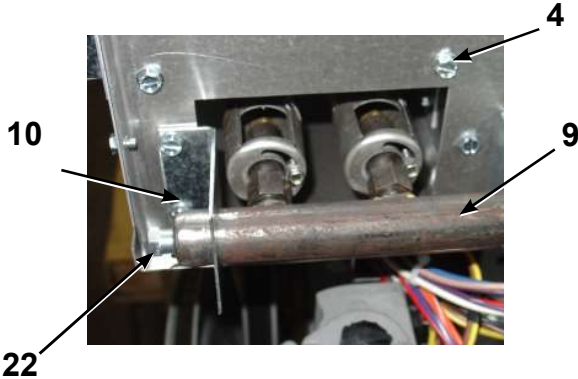

Rear View

Key	Part Number	Description	Quantity
*	9627-861-001	Wire Harness, Overtemperature Switch Upper	1
*	9801-098-001	Switch Assy, Air Flow	2
1	9539-461-009	Switch, Air Flow	2
2	9029-200-001	Bracket, Switch-Air Flow	2
*	8640-401-001	Nut, Special Twin .#4-40	2
*	9550-169-003	Shield, Switch	2
3	9008-007-001	Actuator, Switch.....	2
4	9451-169-002	Pin, Cotter.....	2
5	9545-020-001	Screw, 4-40x 5/8	4
7	9376-322-001	Motor, Drive	2
27	9453-169-013	Motor-Pulley, Driver.....	2
*	9452-770-001	Plate, Motor Mounting	2
9	9962-018-002	Plate, Impeller Mounting.....	2
*	9538-163-006	Spacer, Motor Mounting	8
*	9545-029-008	Screws, Hex Cap.....	8
*	8641-582-003	Lock Washers	8
*	9545-018-019	Screw HXHD 1/4-20 x 2 1/2	8
*	8641-581-017	Washer-Flat, 1/4 x 7/8	32
*	9538-166-006	Spacer, Metal.....	8
12	9991-053-001	Support Assy, Intermediate pulley	2
12	9545-029-010	Bolt, Rd Hd 3/8-16 x 1 1/4	6
12	8640-415-004	Nut Flange Wizlock 3/8 - 16	6
12	8641-581-035	Washer, Flat	6
13	9545-029-003	Bolt, 3/8 - 16 x 1 1/2.....	2
14	9861-022-001	Arm Assy-Tension, Complete.....	2
*	9487-200-003	Ring-Retaining	6
16	9908-048-003	Pulley Assy, Intermediate w/Bronze Flange Bearing	2
*	9036-145-002	Bearing - Bronze Flange	4
17	9908-047-002	Pulley Driven, Tumbler.....	2
*	9487-234-005	Tolerance Ring.....	2
34	8641-581-026	Washer, Flat 1/2" for Tumbler Pulley.....	2
35	9545-017-009	Bolt, 1/2" - 13 x 1 1/4	2
36	8641-582-016	Washer, Star 1/2" for Tumbler Pulley	2
*	9538-184-001	Spacer, Shaft.....	2
19	9040-076-009	Belt, Drive Motor and intermediate.....	2
20	9040-073-011	Belt, Driven-intermediate to.....	2
21	9534-151-000	Spring, Tension.....	2
22	9099-012-005	Chain Tension.....	2
23	9248-022-002	Hook, Tension	2
*	9451-146-001	Pin, Damper Hinge.....	2
*	8520-141-000	Nut, Spring.....	4
*	9825-334-001	Cover, Duct-Upper	1
25	9973-032-001	Heat Recirculation Assembly Duct	2
*	9545-028-013	Set Screw.....	2
30	9278-043-001	Impeller	2
*	9125-007-001	Damper, Exhaust Duct - Upper	1
*	9125-007-002	Damper, Exhaust Duct - Lower	1
*	8520-141-000	Nut, Spring.....	4
*	9545-008-026	Screw #10B x 1/2	14
*	9074-335-001	Cover, Duct - Lower	1
*	9545-008-024	Screw #10AB x 3/8	58
*	9029-173-001	Bracket for Wire Harness Under Burner Housing	2

Rear View Photos - 50lb

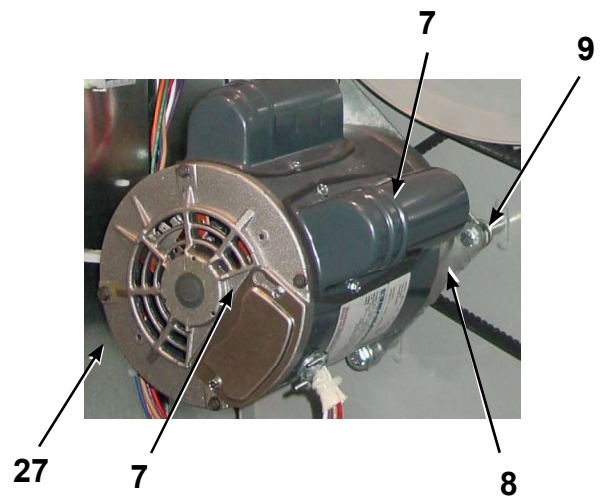
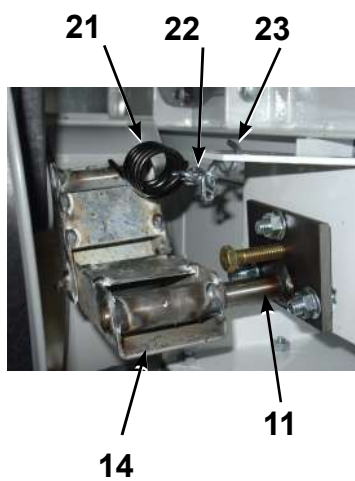
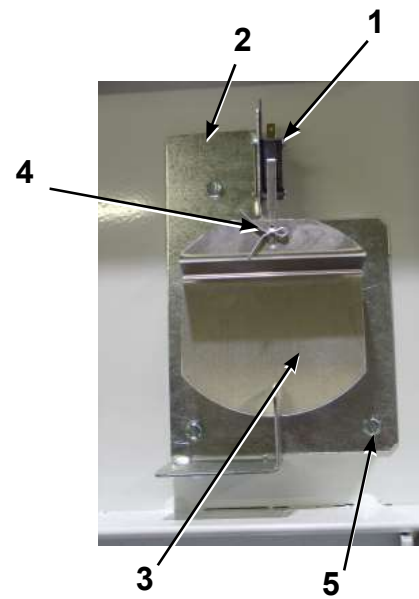
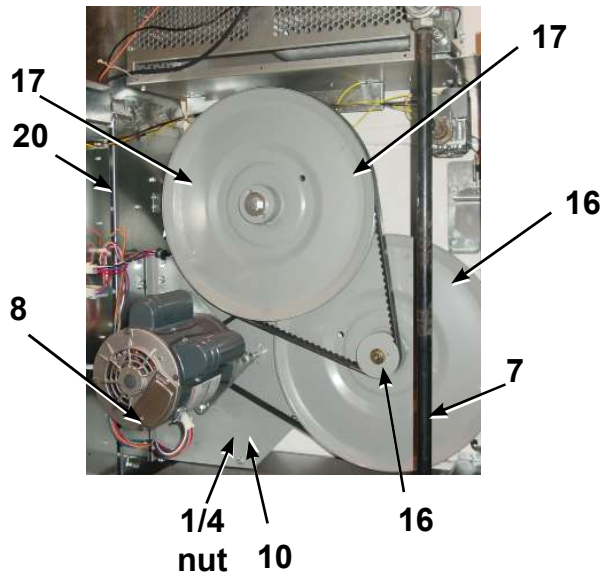
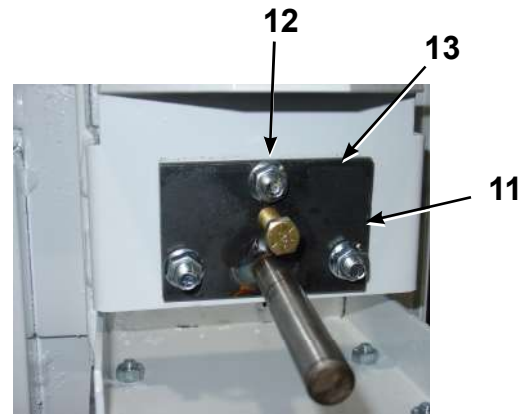
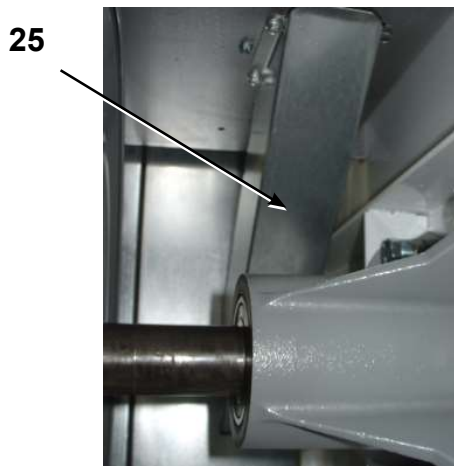

Rear Panel & Cover Group - 50 lbs

Key	Part Number	Description	Quantity
1	9208-090-001	Rear Guard Side Panel 1.....	2
4	9545-008-024	Screws 10 AB x 3/8.....	30
*	9208-089-001	Rear Guard Top, Lower.....	1
7	9545-008-024	Screws 10 AB x 3/8.....	6
8	9208-089-001	Rear Guard Back Panel.....	2
*	9545-008-024	Screws, Guard.....	*
10	8502-600-001	Label Warning & Notice.....	1
11	8502-645-001	Label - Instructions.....	1
12	9109-113-001	Transition Assembly Outlet.....	1
13	9074-320-001	Top Cover Dryer Panel.....	1
14	9550-188-001	Top Burner Housing Heat Shield.....	1

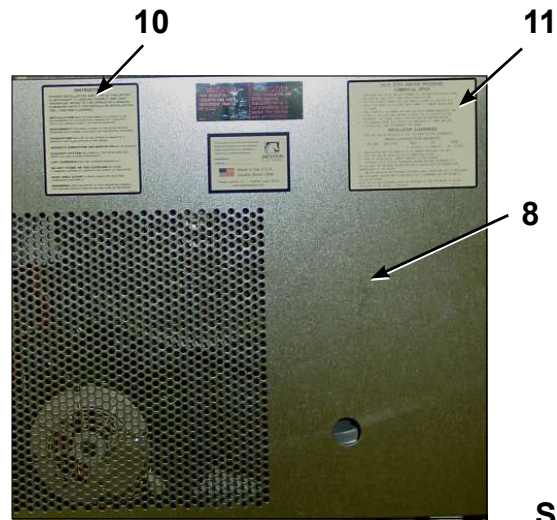
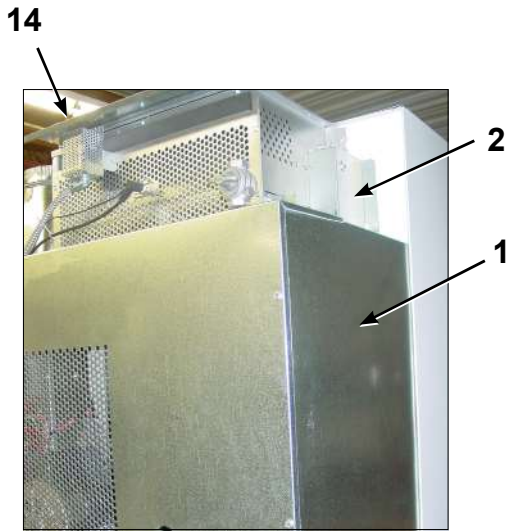

Screws

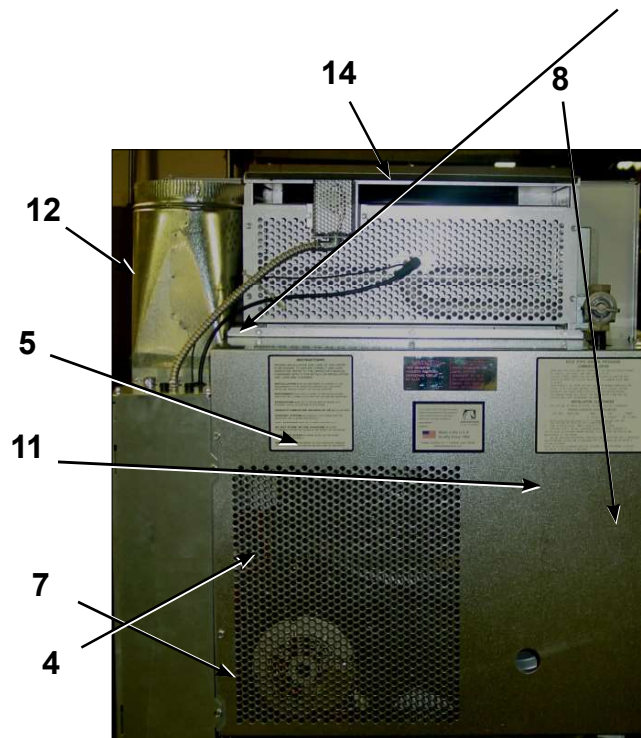
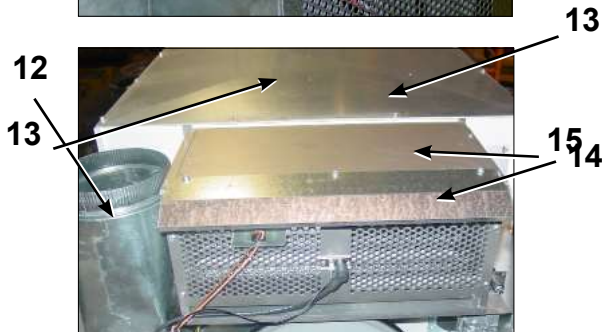

Tumbler Group

Key	Part Number	Description	Quantity
1	9848-148-001	Tumber Assembly Galvanized.....	2
*	9848-157-001	New Tumbler, Taller Baffles (Anti-Roping).....	2
*	9848-148-002	Tumbler Assembly Stainless Steel.....	2
*	9848-149-001	Tumbler Assembly Galvanized w/spider.....	2
*	9848-158-001	New Tumbler, Taller Baffles (Anti-Roping) w/spider.....	2
*	9848-149-002	Tumbler Assembly Stainless w/spider.....	2
2	9568-013-001	Spider Assembly	2
3	9497-226-002	Rod, Tumbler	6
5	8640-417-005	Nut, 1/2 - 136
4	8641-590-002	Washer, Special	6
6	9552-013-000	ShimAR

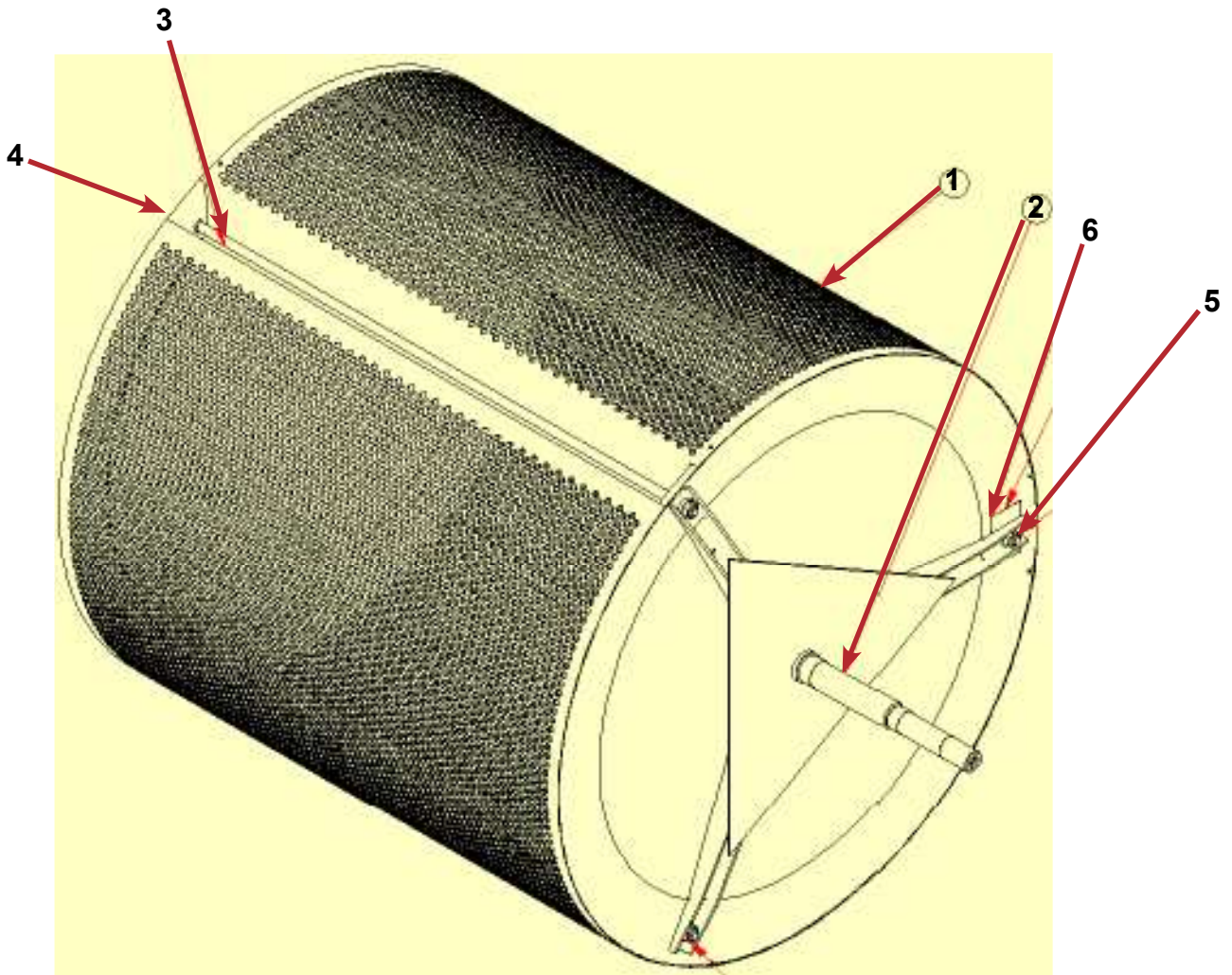

Control Assembly Group

Key	Part Number	Description	Quantity
*	9857-187-003	Control Assembly Complete (all below included)	1
*	9074-317-001	Control Box Cover	1
1	8653-068-003	Connector Conduit 3/8" STR.....	1
2	9558-029-003	Strip Terminal Marker (Behind Input Power) to above #3	1
3	9897-035-001	Terminal Block Assembly Main Power Inlet	1
*	9545-008-024	Screws 10AB x 3/8"	4
*	9627-859-003	Wire Harness - Power Main	1
4	8220-001-478	Wire Assembly Green 7"	1
5	9545-008-027	Screw # 10-32 x 12 Green	1
*	8641-582-006	Lockwasher Ext Tooth #10.....	1
6	9897-026-002	Terminal Block Main Power Middle	1
7	9897-026-001	Terminal Block.....	2
*	9545-045-012	Screw #8 ABx1 2 for terminal block.....	6
8	8711-013-001	Transformer Control.....	1
*	9545-008-024	Screws 10AB x 3/8"	4
9	9857-182-001	Ignition Control	2
*	9545-008-018	Screws 10AB x 3/4"	4
10	9631-403-009	Wire Assembly High Voltage Upper.....	1
11	9627-867-005	Wire Harness Ignition Control Upper.....	1
12	9631-403-008	Wire Assembly High Voltage Lower.....	1
13	9627-867-006	Wire Harness Ignition Control Lower.....	1
*	9053-067-002	Bushing Wire 7/8".....	4
14	9200-001-002	Fuseholder Assembly.....	3
*	8636-018-001	Fuse 1.5 Amp.....	2
*	8636-018-004	Fuse 2.5 Amp.....	1
15	5192-299-001	Relay Power.....	2
*	9545-045-012	Screws Power #8 AB x 1/2".....	4
*	8220-062-036	Wire Assembly Red/Black 14".....	1
*	8220-062-037	Wire Assembly Red/White 14".....	1
16	9627-864-006	Wire Harness Motor Extension.....	2
17	9527-007-001	Stand Off - Wire Saddle / Arrowhead	5
18	9627-863-001	Wire Harness Main Extension Access Under Burner Housing	4

Control Protection Fuse 2.5 Amp **14** **1** **14** Ignition Upper Pocket Protection Fuse 1.5 Amp

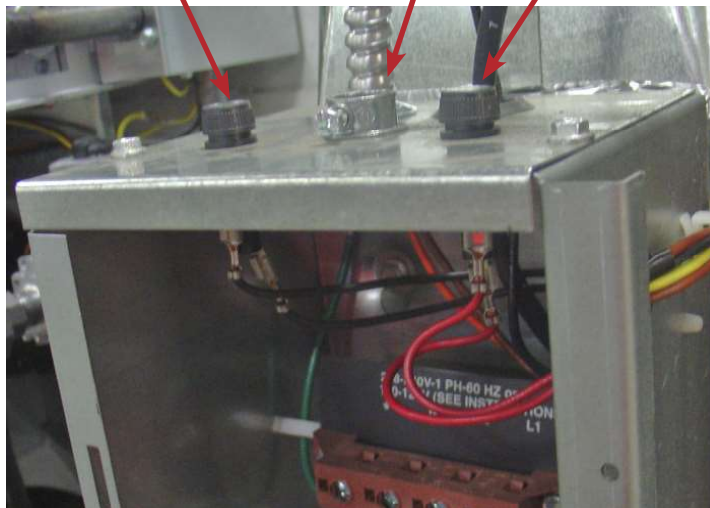

Not Shown:
24VAC Ignition Lower
Pocket Protection
Fuse

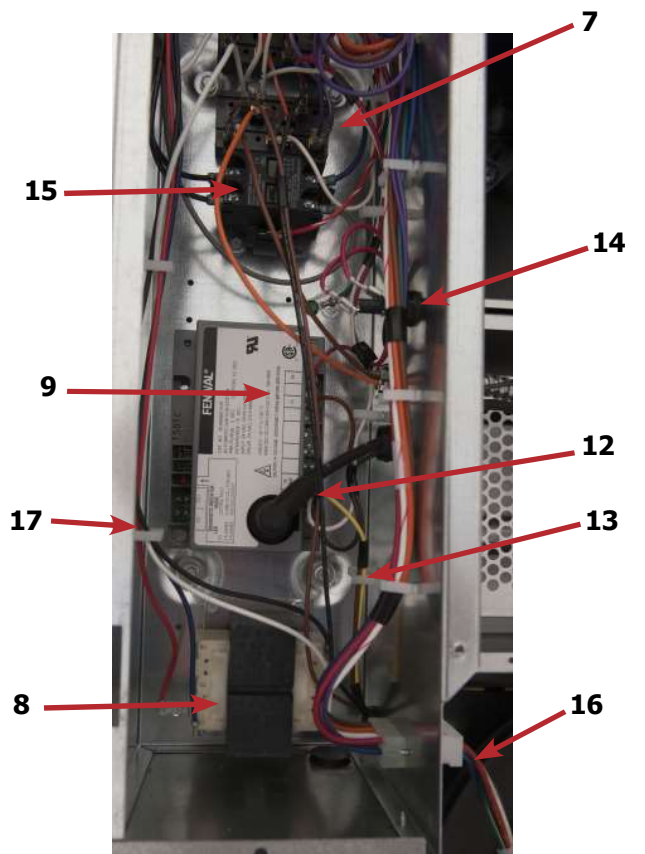
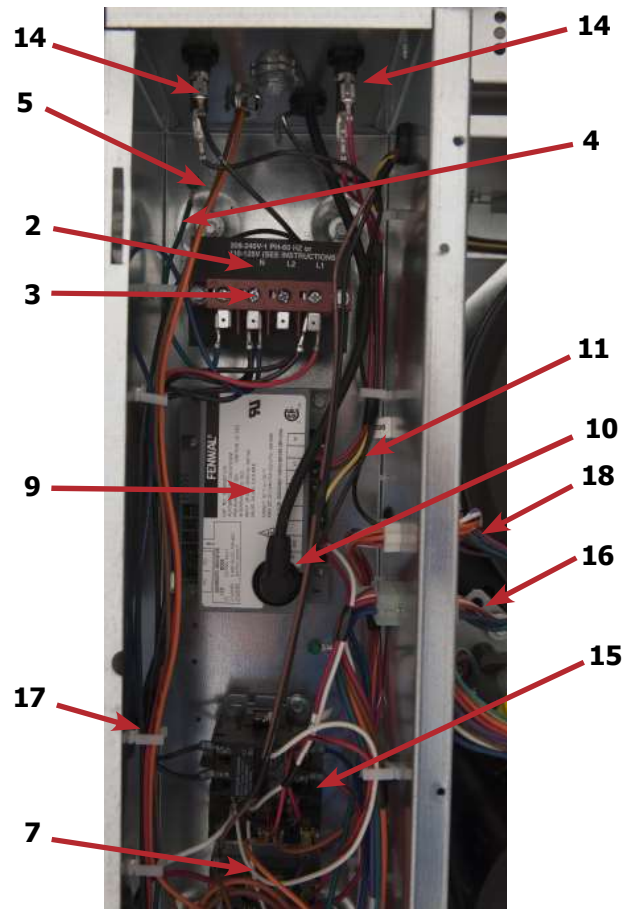
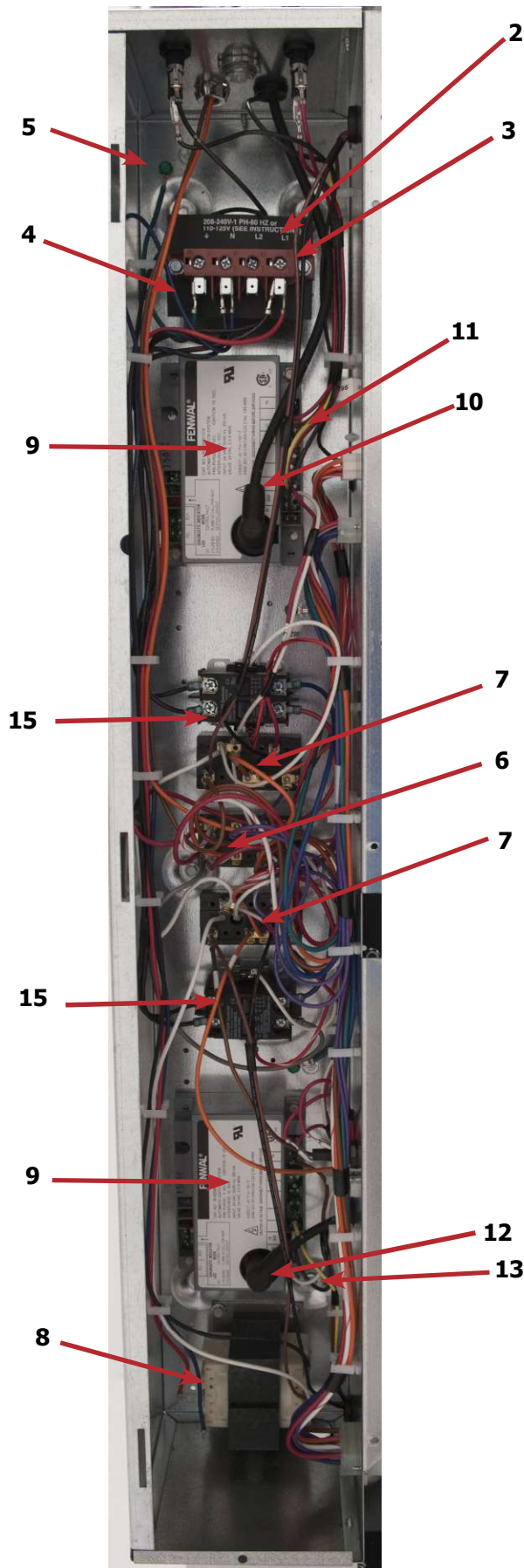

Door Switch Group

Part Number
9539-487-001

Description
Door Switches 2

Quantity



Section 8:

Electric Heated 60Hz

Electric Heated Parts DN30X2EC-71/-74EB

Key	Part Number	Description	Quantity
*	8220-001-499	Wire-BLK, 26"	2
*	8220-057-016	Wire-BLK, 8", 8 AWG.....	6
*	8220-057-021	Wire-WHT, 5 1/2", 18 AWG.....	2
*	8220-057-023	Wire-BLK, 9 1/2", 10 AWG.....	12
*	8220-057-031	Wire-BLK, 36", 12 AWG.....	1
*	8220-057-032	Wire-RED, 36", 12 AWG.....	1
*	8220-061-011	Wire-BLK, 17", 10 AWG	12
*	8220-063-020	Wire-WHT/BLK, 65" 18 AWG.....	1
*	8220-078-014	Wire-BLK, 22" 18 AWG.....	2
*	8220-095-023	Wire-BRN, 54" 18 AWG.....	2
*	8220-103-002	Wire-Red, 19" 18AWG.....	2
*	9636-155-001	Wrapper-Housing, Heater.....	2
*	9545-008-001	Screw 10B x 1/4.....	6
*	9551-032-001	Side-Housing, Heater, Right Hand.....	2
*	9551-033-001	Side-Housing, Heater, Left Hand.....	2
*	9551-040-001	Side Control Heater.....	4
*	9114-044-001	Defl ector-Bottom Housing.....	2
*	9545-008-024	Screw-10AB x 3/8.....	6
*	9058-026-001	Bottom-Housing, Heater.....	2
*	9545-008-024	Screw-10AB x 3/8.....	22
*	9114-045-001	Defl ector-Wraper, Housing.....	2
*	9545-008-024	Screw-10AB x 3/8.....	8
*	9114-046-001	Defl ector-Baffl e.....	12
*	9049-078-001	Baffl e-Housing, Heater.....	2
*	9636-191-001	Wrapper-Control, Heater.....	2
*	9074-293-001	Cover-Plate, Heater.....	2
*	9551-040-001	Side-Control Heater.....	4
*	9545-008-024	Screw-10AB x 3/8.....	16
*	9029-194-001	Bracket-Control, Heater.....	4
*	9074-333-001	Cover-Control, Heater.....	2
*	9545-018-014	Screw-1/4-20 x 3/4.....	8
*	9277-041-014	Insulation.....	2
*	9029-181-001	Bracket-Back, Panel.....	1
*	9074-337-001	Cover-Terminal, Heater.....	2
*	9576-207-006	Thermostat-Overtemp, Manual reset.....	2
*	9538-166-005	Spacer Over Temp Thermostat.....	4
*	9982-364-001	Plate Assembly-Overtemp switch.....	2
*	9627-861-002	Harness-Over Temp Switch.....	2
*	9348-066-001	Lever-Overtemp Switch.....	2
*	9452-769-001	Plate-Over Temp Switch.....	2
*	9497-229-001	Rod-Over Temp Switch.....	2
*	9488-011-002	Rail-Din, 35 x 15mm.....	2

DN30X2EC-71/-74EB 240/60/3 24KW

Key	Part Number	Description	Quantity
*	5192-285-004	Relay.....	2
*	5192-296-001	Relay, Heating Element.....	2
*	9377-003-001	Varister-Coil Suppressor.....	2
*	5198-213-002	Circuit Breaker-3 Pole.....	4
*	8652-134-002	Terminal-Lug, Solderless.....	4
*	9870-093-004	Heater Element, 12KW 208V.....	6
*	9295-004-002	Jumper-Formed.....	4
*	9295-005-002	Jumper-Straight.....	8
*	9897-037-001	Block-Power, 3 Pole.....	2
*	9897-038-001	Block-Power, 1 Pole.....	2
*	9506-466-001	Wiring-Schematic.....	1
*	9506-467-001	Wiring-Diagram.....	1
*	9506-468-001	Wiring-Diagram/Schematic.....	1
*	8514-202-001	Booklet-Owners, DDAD30HC_-16FC.....	1

30Lb Schematic Diagram -71

IMPORTANT: RETAIN THIS ELECTRICAL SCHEMATIC FOR SERVICE.
9506-466-002PR

SCHEMATIC

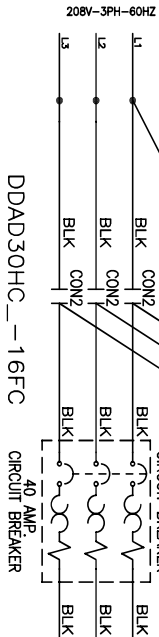
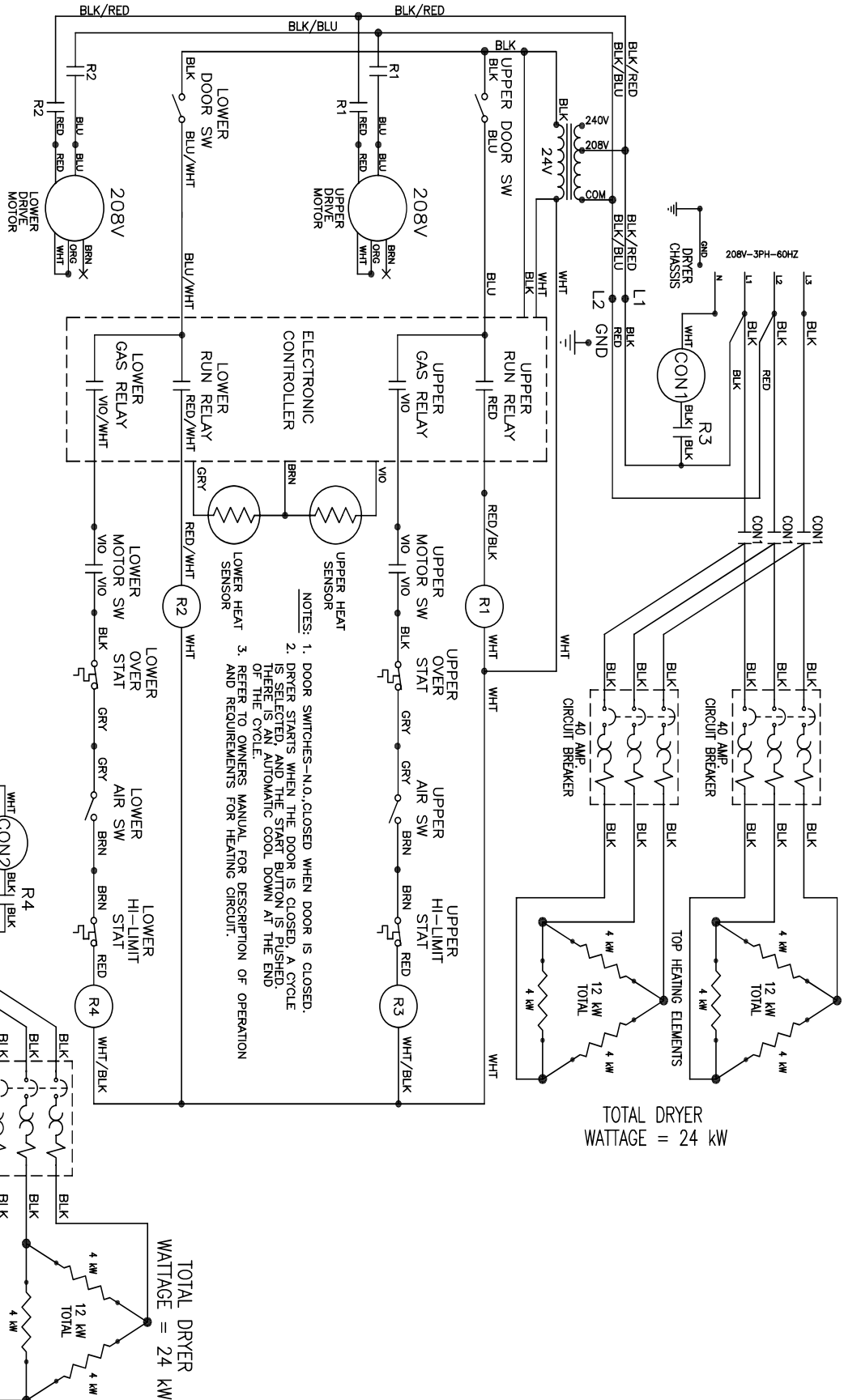

30Lb Wiring Diagram -71

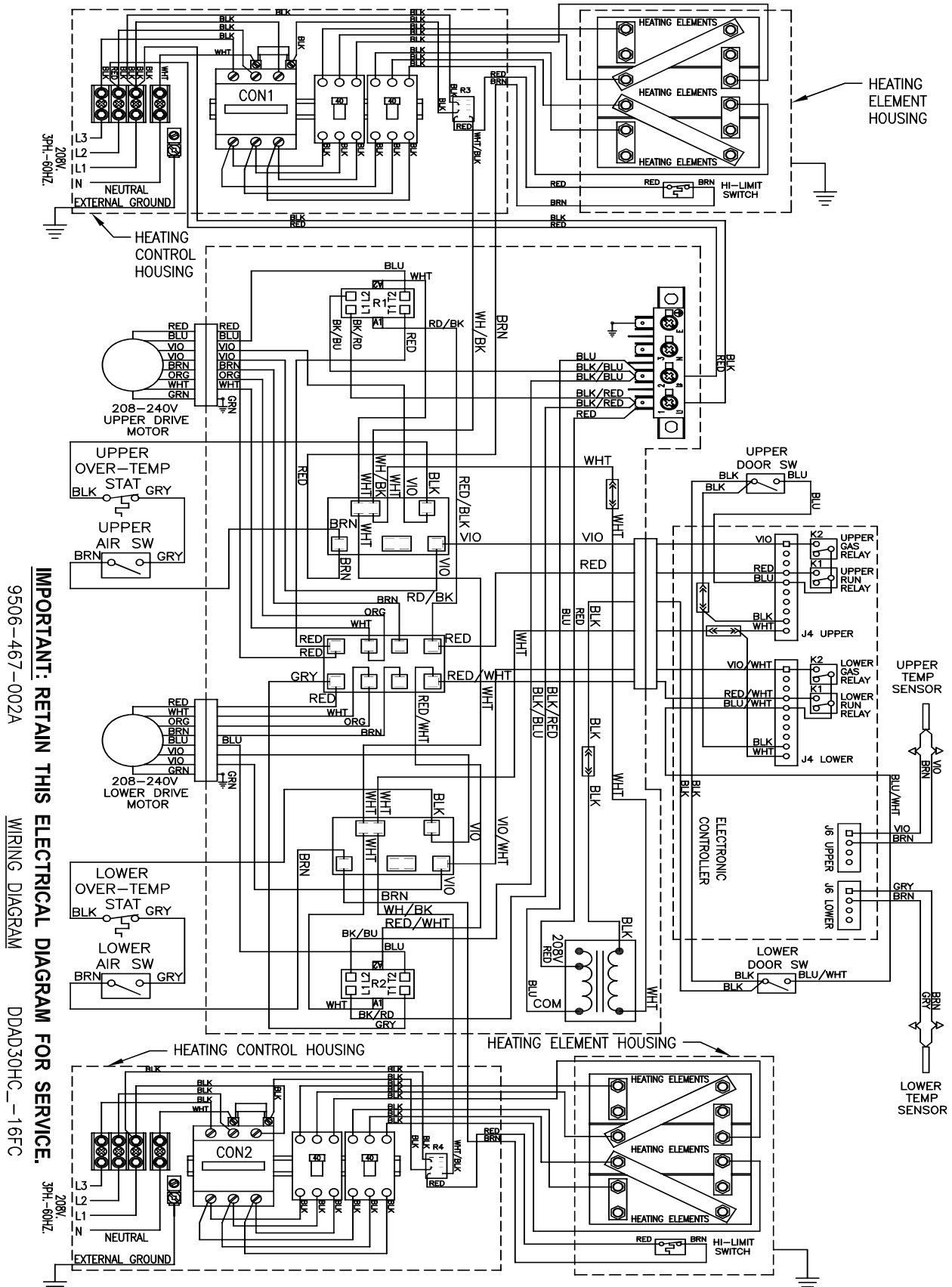

30Lb Schematic Diagram -74

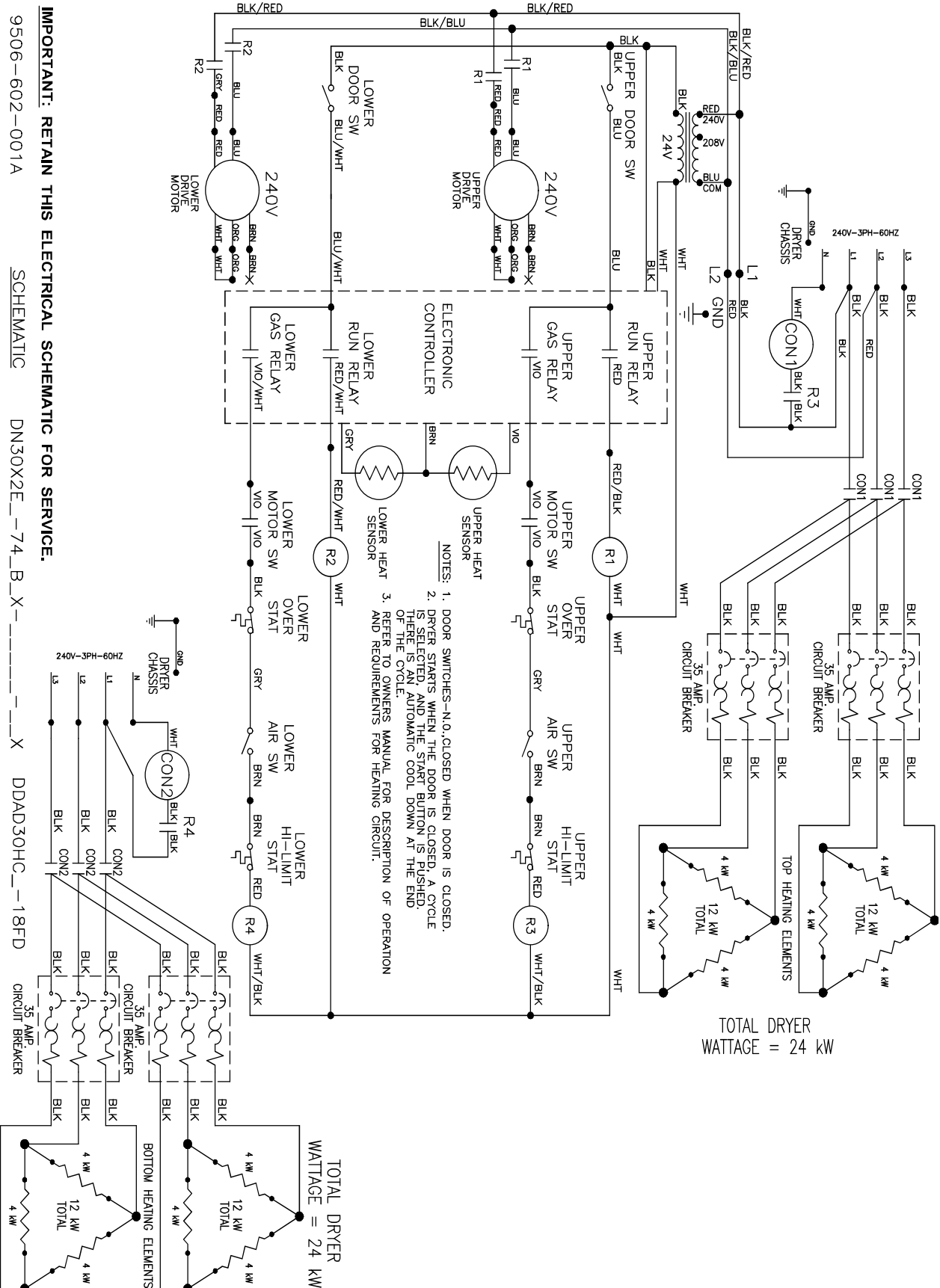

30Lb Wiring Diagram -74

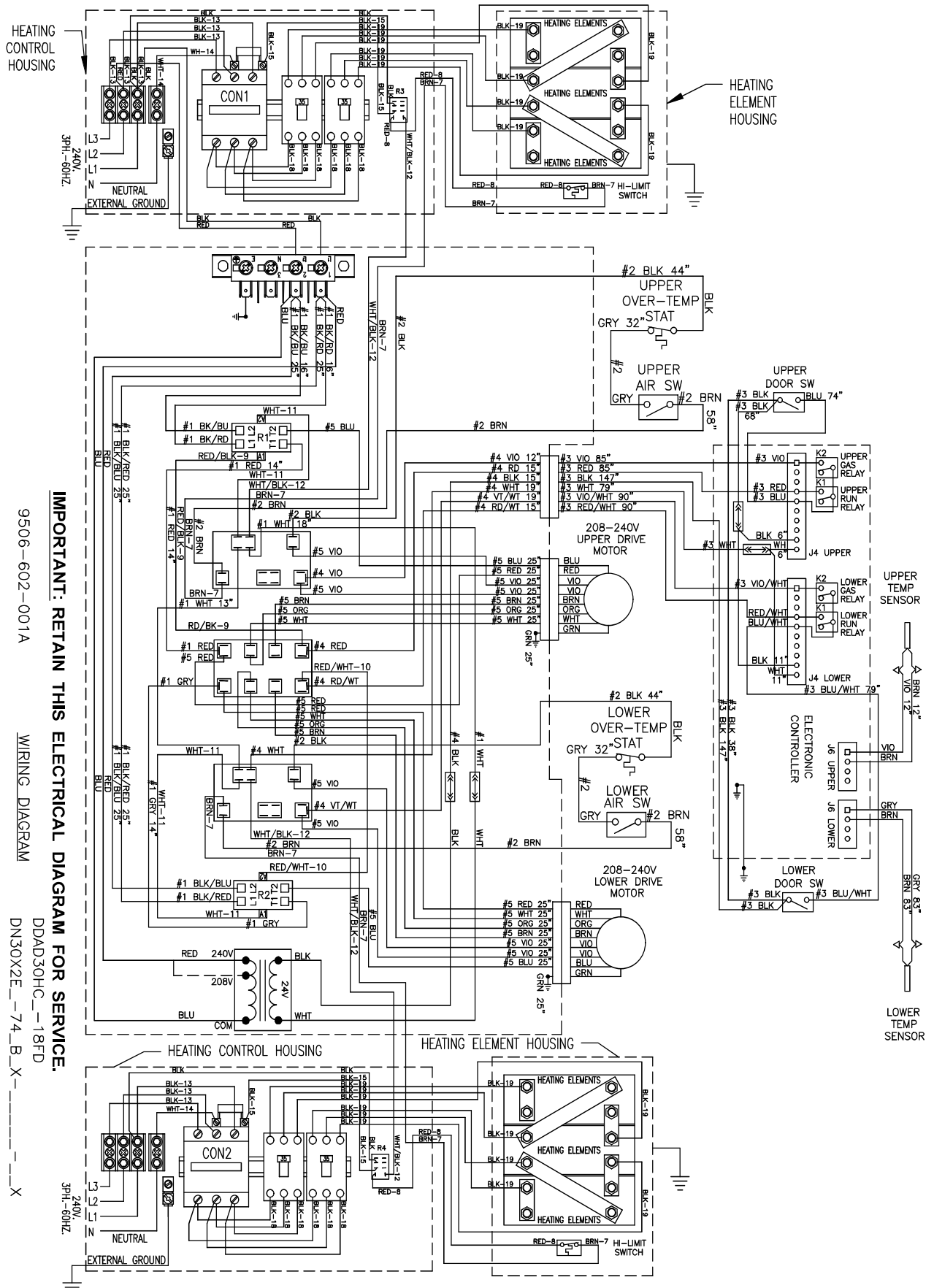

IMPORTANT: RETAIN THIS ELECTRICAL DIAGRAM FOR SERVICE.
 9506-602-001A WIRING DIAGRAM
 DDAD30HC-18FD
 DN30X2E-74_B_X

30Lb Wiring Diagram -77

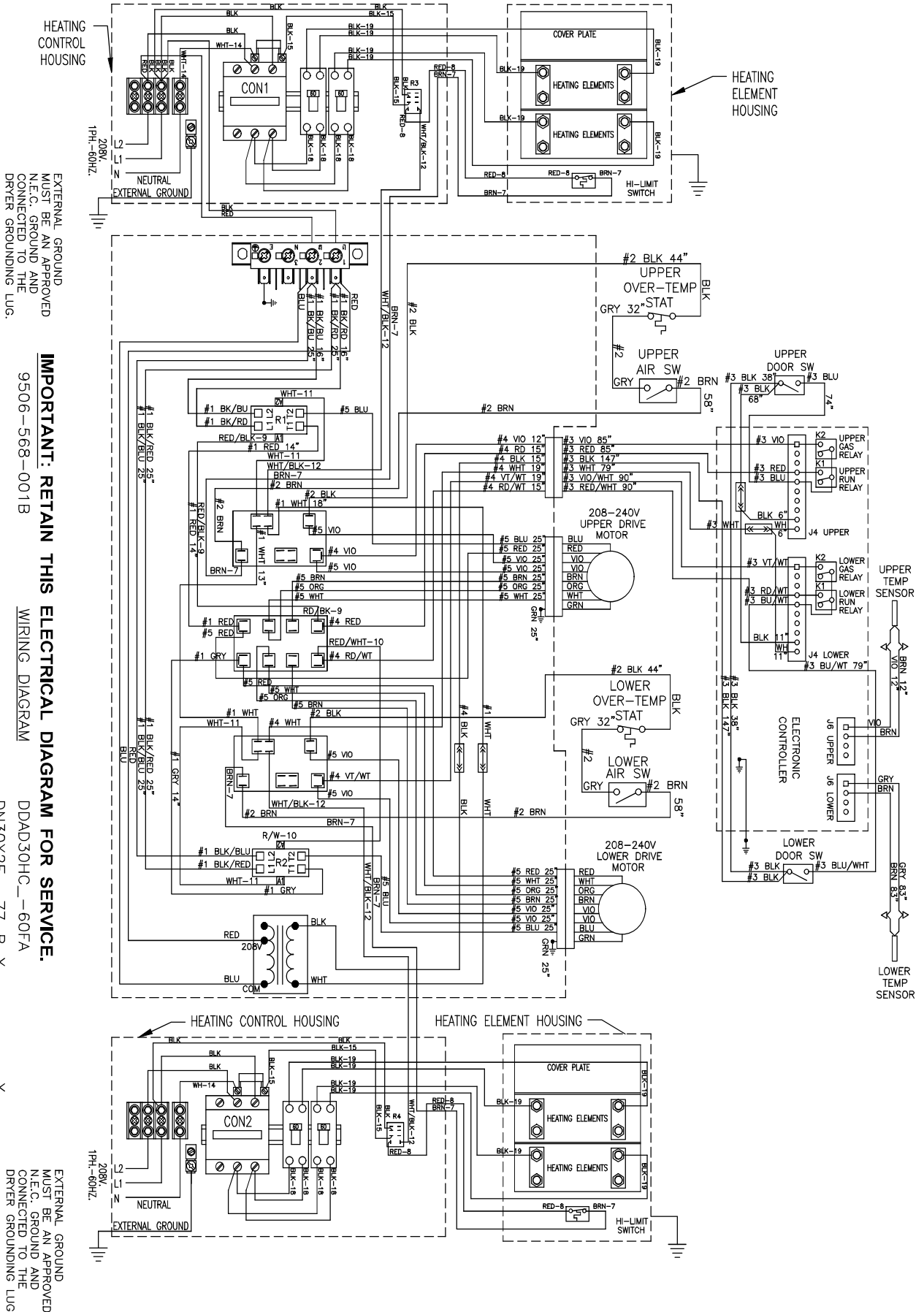

EXTERNAL GROUND
MUST BE AN APPROVED
N.E.C. GROUND AND
CONNECTED TO THE
DRYER GROUNDING LUG.

IMPORTANT: RETAIN THIS ELECTRICAL DIAGRAM FOR SERVICE.

9506-568-001B
WIRING DIAGRAM
DDAD30HC-60FA
DN30XE-77_B-X

EXTERNAL GROUND
MUST BE AN APPROVED
N.E.C. GROUND AND
CONNECTED TO THE
DRYER GROUNDING LUG.

30Lb Schematic Diagram -78

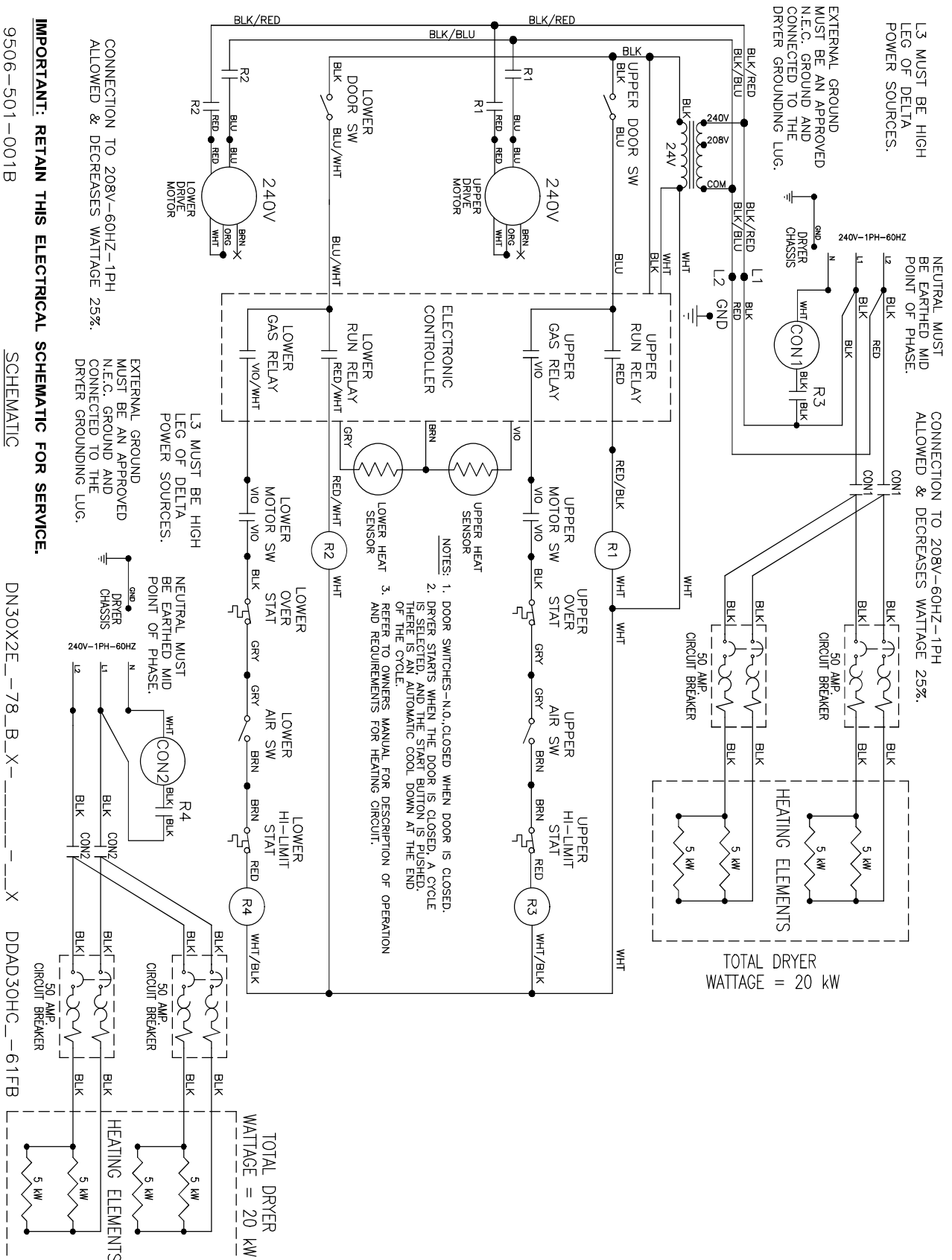

30Lb Wiring Diagram -78

NEUTRAL MUST BE EARTHED MID POINT OF PHASE.
L3 MUST BE HIGH LEG OF DELTA POWER SOURCES.

HEATING CONTROL HOUSING

EXTERNAL GROUND MUST BE AN APPROVED N.E.C. GROUND AND CONNECTED TO THE DRYER GROUNDING LUG.

CONNECTION TO 208V-60HZ-1PH ALLOWED & DECREASES WATTAGE 25%.

CONNECTION TO 208V-60HZ-1PH ALLOWED & DECREASES WATTAGE 25%.

NEUTRAL MUST BE EARTHED MID POINT OF PHASE.
L3 MUST BE HIGH LEG OF DELTA POWER SOURCES.

HEATING CONTROL HOUSING

EXTERNAL GROUND MUST BE AN APPROVED N.E.C. GROUND AND CONNECTED TO THE DRYER GROUNDING LUG.

CONNECTION TO 208V-60HZ-1PH ALLOWED & DECREASES WATTAGE 25%.

CONNECTION TO 208V-60HZ-1PH ALLOWED & DECREASES WATTAGE 25%.

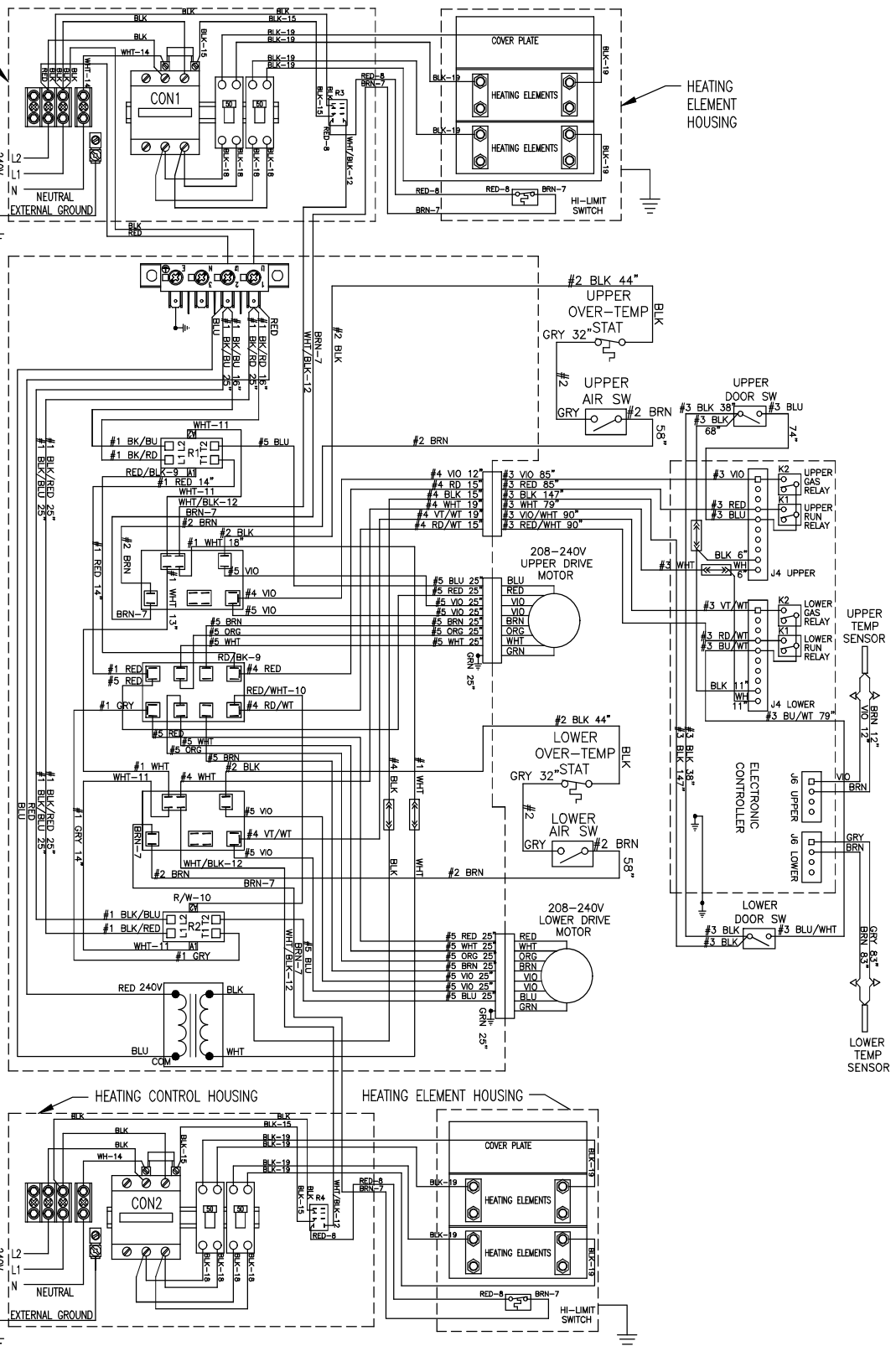

IMPORTANT: RETAIN THIS ELECTRICAL DIAGRAM FOR SERVICE.

WIRING DIAGRAM

DDAD30HC_61FB
DN30X2_78_B_X

30Lb Schematic Diagram -79

9506-459-001C

DDAD30HC_ -64FN/DN30X2E_ -79CB_X

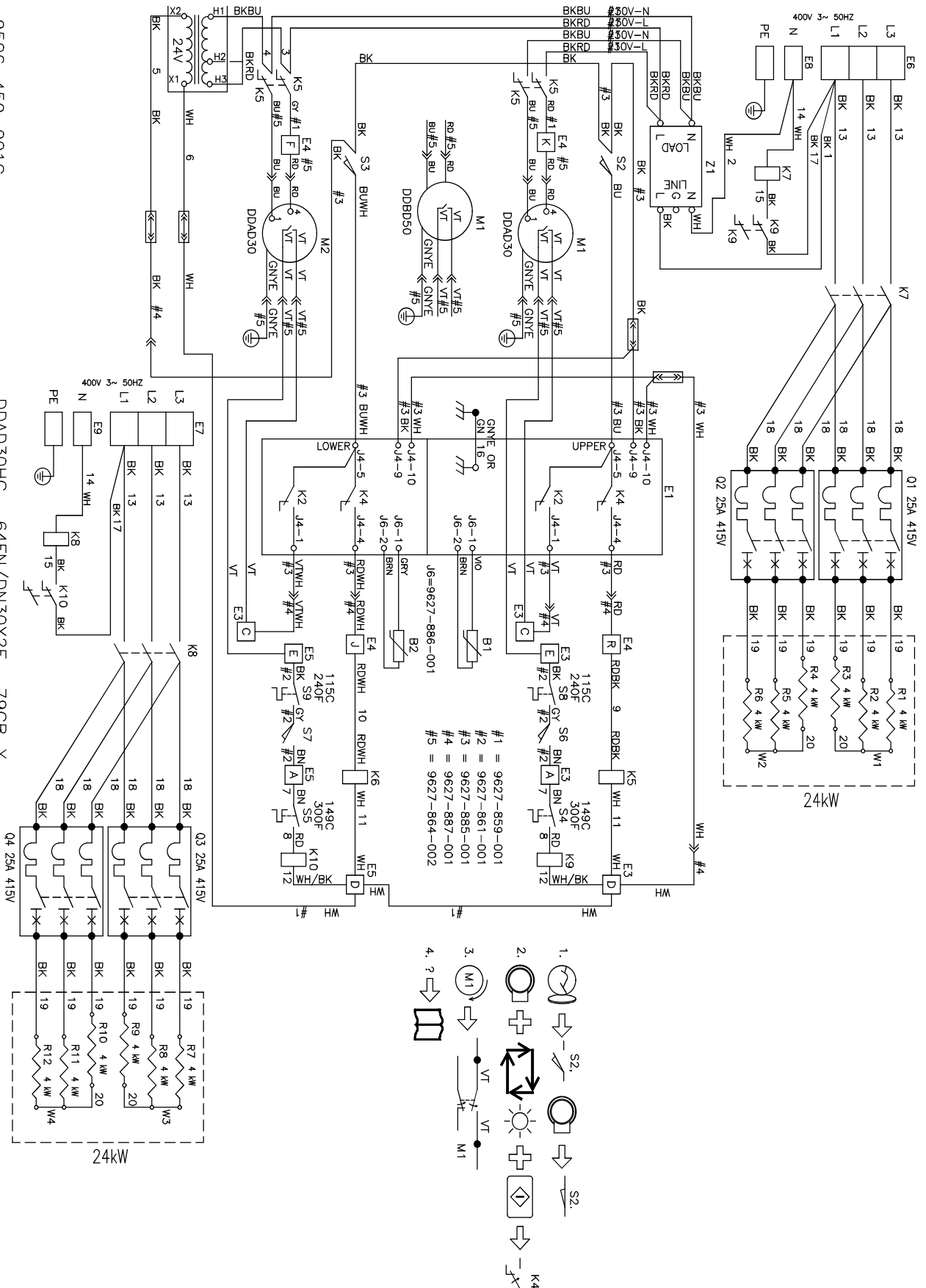

30Lb Wiring Diagram -79

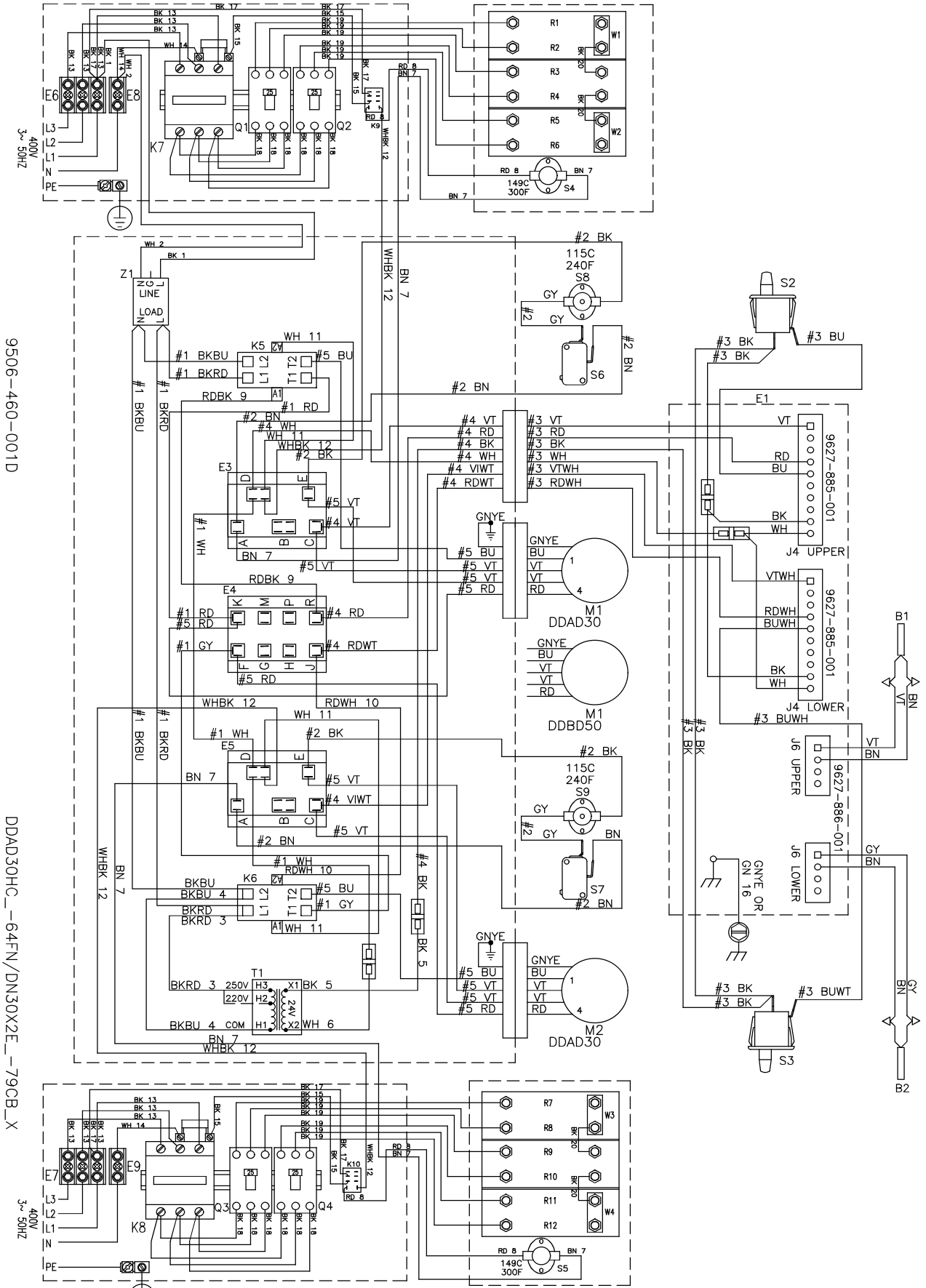

9506-460-001D

DDAD30HC--64FN/DN30XZE--79CB_X

