



# Section 8:

## Parts Data

WCAD-Series Vended Washers  
T300, T400, T600 (100G)  
& T350, T450 (Express  
Washers 200G)

## A-Series Accessories

WCAD20KCS-10	120 volts	60hz.	Single Phase
WCAD20KCS-12	208-240 volts	60hz.	Single Phase or Three Phase
WCAD20KCS-12SZ	208-240 volts	60hz.	Single Phase or Three Phase
WCAD30KCS-12	208-240 volts	60hz	Single Phase or Three Phase
WCAD30KCS-12SZ	208-240 volts	60hz	Single Phase or Three Phase
WCAD40KCS-12	208-240 volts	60hz	Single Phase or Three Phase

Key	Description	T-300	T-350	T-400	T-450	T-600	QTY
*	Kit, Door Gasket Expander (large)	9732-139-002	9732-139-002	9732-139-002	9732-139-002	9732-139-002	
*	Kit, Door Gasket Expander (small)	9732-139-001	9732-139-001	9732-139-001	9732-139-001	9732-139-001	
*	Hose, Water Supply 3/8" I.D. x 48"	9990-027-011	9990-027-011	9990-027-011	9990-027-011	9990-027-011	2
*	Washer, Inlet Hose (furnished)	8641-242-000	8641-242-000	8641-242-000	8641-242-000	8641-242-000	2
*	Strainer, Inlet Hose (furnished)	9565-003-001	9565-003-001	9565-003-001	9565-003-001	9565-003-001	2
*	Bevel Washer for 5/8" bolt used in installations using angle iron bases	8641-586-002	8641-586-002	8641-586-002	8641-586-002	8641-586-002	
*	Bevel Washer for 3/4" bolt used in installations using angle iron bases	8641-586-003	8641-586-003	8641-586-003	8641-586-003	8641-586-003	
*	Sealing compound	8538-151-001	8538-151-001	8538-151-001	8538-151-001	8538-151-001	
*	TORX#20	8545-051-002	8545-051-002	8545-051-002	8545-051-002	8545-051-002	
*	Flow Restrictors (in dispenser )	9475-002-002	9475-002-002	9475-002-002	9475-002-002	9475-002-002	2
*	Battery (used on Control PCB)	8612-001-001	8612-001-001	8612-001-001	8612-001-001	8612-001-001	
*	VFD Filter options (1 phase) 120v	9732-233-001					
*	VFD Filter options (3 phase)	9732-234-001	9732-231-001	9732-231-001	9732-231-001	9732-231-001	
*	VFD Filter options (1 phase) 220VAC	9732-235-001	9732-232-001	9732-232-001	9732-232-001	9732-232-001	
*	Coin Bearing & Seal Kit	9732-219-001	9732-219-002	9732-219-002	9732-219-004	9732-219-004	
*	Coin Op CD with OS2 Platform for A Series Washers Only	9504-015-001	9504-015-001	9504-015-001	9504-015-001	9504-015-001	
*	Coin Box Assy, Blue Small	9807-099-001	9807-099-001	9807-099-001	9807-099-001	9807-099-001	1
	Coin Box Assy, Black Small	9807-099-003	9807-099-003	9807-099-003	9807-099-003	9807-099-003	1

## Wiring Harness Part # by Model

Key	Description	T-300	T-350	T-400	T-450	T-600	QTY
*	Wiring Harness (Add Bleach Lite assy included)	9794-001-001	9794-001-001	9794-001-001	9794-001-001	9794-001-001	1
*	Wiring Harness, Door Lock	9627-791-003	9627-791-003	9627-791-003	9627-791-003	9627-791-004	1
*	Wiring Harness,CoinDrop Mech	9627-792-001	9627-792-001	9627-792-001	9627-792-001	9627-792-001	1
*	Wiring Harness, Drain,Thermo,DoorSol	9627-796-001	9627-796-001	9627-796-001	9627-796-001	9627-796-002	1
*	Data Cable	9806-015-001	9806-015-001	9806-015-001	9806-015-001	9806-015-001	1
*	Wiring Harness P20/P21	9627-793-001	9627-793-001	9627-793-001	9627-793-001	9627-793-001	1
*	Wiring Harness P8/P16	9627-794-001	9627-794-001	9627-794-001	9627-794-001	9627-794-001	1
*	Wiring Harness WaterValve/P19	9627-795-003	9627-795-003	9627-795-003	9627-795-003	9627-795-004	1
*	Wiring Harness LED PCB	9627-797-001	9627-797-001	9627-797-001	9627-797-001	9627-797-001	1
*	Wiring Harness P5/pressure	9627-800-001	9627-801-001	9627-801-001	9627-801-001	9627-802-001	1
*	Wiring Assembly Yel. 32"	8220-064-023	8220-064-023	8220-064-023	8220-064-023	8220-064-023	2
*	Wiring Assembly Red 20"	8220-001-282	8220-001-282	8220-001-282	8220-001-282		2
*	Wiring Assembly Vio. 24"	8220-118-001					2
*	Wiring Assembly Jumper Yel	8220-123-001	8220-123-001	8220-123-001	8220-123-001	8220-123-001	1
*	Wiring Assembly Red 28"					8220-062-025	2
*	Wiring Assembly Blk. 17"	8220-062-028	8220-062-026	8220-062-026	8220-063-026	8220-062-026	1
*	Wiring Assembly Red 17"	8220-062-027	8220-062-025	8220-062-025	8220-063-025	8220-062-025	1
*	Wiring Assembly Jumper BLK.		8220-117-002	8220-117-002	8220-117-002	8220-117-002	2
*	Wiring Assembly Red 7"	9631-381-018	9631-381-018	9631-381-018	9631-381-018	9631-381-018	1
*	Wiring Assembly Blu/Wht	8220-090-009	8220-090-009	8220-090-009	8220-090-009	8220-090-009	1
*	Wiring Assembly Blk/Blu	8220-001-231	8220-001-231	8220-001-231	8220-001-231	8220-001-231	1
*	Wire Assembly Green 7"	8220-001-478					1
*	Harness Power Terminal Block	9627-831-001	9627-831-001	9627-747-003	9627-747-003	9627-747-003	1
	Wire Assy-Red 29"	8220-065-030					1
	Wire Assy-Blue 29"	8220-065-031					1
	Wire Assy-Black 4"	8220-062-023					1

# Cabinet and Front Panel Group Part # by Model

Key	Description	T-300	T-350	T-400	T-450	T-600	QTY
1	Panel, Side (Left or Right) - stainless			9454-829-001	9454-830-001	9454-815-001	2
1	Panel, Right Side-stainless	9454-825-001	9454-828-001				1
1	Panel, Left Side - stainless	9454-825-002	9545-828-002				1
2	Screw, (Side Panel to Base)	9545-018-018	9545-018-018	9545-018-013	9545-018-013		6
2	Screw, (Side Panel to Base)					9545-018-013	8
2	Nut, Hex 1/4-20 UNC	8640-414-006	8640-414-006	8640-414-006	8640-414-006		6
2	Nut, Hex 1/4-20 UNC					8640-414-006	8
*	Pad-Foam, Side Panel	0904-904-001	0904-904-001	0904-904-001	0904-904-001	0904-904-001	2
3	Vault Assembly, Coin	9942-033-008	9942-033-008	9942-033-009	9942-033-009	9942-033-009	1
*	Screw, #10B x 1/2	9545-008-026	9545-008-026	9545-008-026	9545-008-026	9545-008-026	2
4	Chute-Coin	9119-031-001	9119-031-001	9119-031-001	9119-031-001	9119-031-001	1
*	Screw, 10B x 1/4	9545-008-001	9545-008-001	9545-008-001	9545-008-001	9545-008-001	1
*	Bracket, Side Panel under front panel	9029-066-001	9029-066-001	9029-165-001	9029-165-001	9029-165-001	1
*	Nut, Hex (to tub front)	8640-413-002	8640-413-002	8640-413-002	8640-413-002	8640-413-002	2
*	Screw, #10B x 1/2	9545-008-031	9545-008-026	9545-008-026	9545-008-026	9545-008-026	2
5	Panel, Control (Mounts Nameplate) If Replacing before Serial # 530002 Will require 2 of Coin Mech Retaining Brackets # 9486-149-001	9989-522-001	9989-522-001	9989-523-001	9989-523-001	9989-524-001	1
*	Screw, Control Panel to Sides	9545-008-026	9545-008-026	9545-008-026	9545-008-026	9545-008-026	4
6	Nameplate Decal, Control Panel (Blue)	9412-135-001	9412-156-001	9412-137-001	9412-159-001	9412-139-001	1
6	Nameplate Decal, Control Panel (Black)	9412-168-001	9412-169-001	9412-170-001	9412-166-001	9412-171-001	1
7	Label-Nameplate, RH (Blue)	8502-726-001	8502-726-001				1
7	Label-Nameplate, RH (Black)	8502-744-001	8502-744-001				1
*	Stop Button Mounting Plate	9452-725-001	9452-725-001	9452-725-001	9452-725-001	9452-725-001	1
8	Kit-Stop button with harness & Switch	9732-223-001	9732-223-001	9732-223-001	9732-223-001	9732-223-001	1
9	Acceptor, Coin-Optical switch w/harness	9021-016-001	9021-016-001	9021-016-001	9021-016-001	9021-016-001	1
*	Retainer-Dual coin Acceptor	9486-149-001	9486-149-001	9486-149-001	9486-149-001	9486-149-001	2
*	Screws, Coin Acceptor	9545-053-002	9545-053-002	9545-053-002	9545-053-002	9545-053-002	4
10	Panel Assy, Front	9454-781-001	9454-781-001	9454-659-001	9454-659-001	9454-669-001	1
11	Band, Edge Protector	9059-063-004	9059-063-004	9059-063-002	9059-063-002	9059-063-002	1
*	Screw, Hex- To Control Panel	9545-008-031	9545-008-031	9545-008-031	9545-008-031	9545-008-031	2
*	Nut, Spring- To Control Panel 10/32	8640-399-005	8640-399-005	8640-399-005	8640-399-005	8640-399-005	4
12	Screw, Flat Head- Front to Sides	9545-008-014	9545-008-014	9545-008-014	9545-008-014	9545-008-014	2
13	Washer, Finish	8641-585-001	8641-585-001	8641-585-001	8641-585-001	8641-585-001	2
*	Nut, Spring-To Front Panel	8640-399-008	8640-399-008	8640-399-008	8640-399-008	8640-399-008	2
14	Label, Door Opening-Blue	8502-723-001	8502-723-001	8502-723-001	8502-723-001	8502-723-001	1
14	Label, Door Opening-Black	8502-742-001	8502-742-001	8502-742-001	8502-742-001	8502-742-001	
15	Label, Warning Risk of Injury-Blue	8502-722-002	8502-722-002	8502-722-002	8502-722-002	8502-722-002	1
	Label, Warning Risk of Injury-Black	8502-741-001	8502-741-001	8502-741-001	8502-741-001	8502-741-001	1

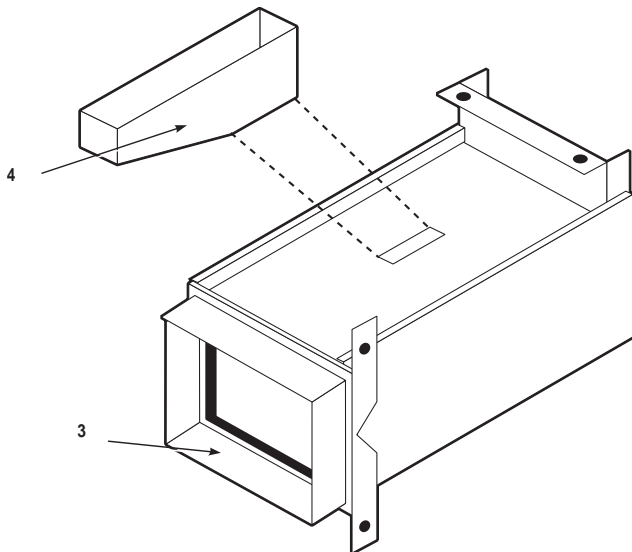

Key	Description	T-300	T-350	T-400	T-450	T-600	QTY
16	Door, Lower Service (includes handle & Rivets)	9960-286-001	9960-286-001	9960-286-002	9960-286-002	9960-286-002	1
17	Handle (bumper guard)	9244-086-001	9244-086-001	9244-086-002	9244-086-002	9244-086-002	1
*	Rivet	9491-009-003	9491-009-003	9491-009-003	9491-009-003	9491-009-003	4
18	Screw Mtg., Flat Head	9545-008-014	9545-008-014	9545-008-014	9545-008-014	9545-008-014	2
19	Washer, Finish	8641-585-001	8641-585-001	8641-585-001	8641-585-001	8641-585-001	2
*	Nut, Spring	8640-399-008	8640-399-008	8640-399-008	8640-399-008	8640-399-008	2
20	Coin Box Assy, Blue Small	9807-099-001	9807-099-001	9807-099-001	9807-099-001	9807-099-001	1
	Coin Box Assy, Black Small	9807-099-003	9807-099-003	9807-099-003	9807-099-003	9807-099-003	1

# Cabinet and Front Panel Group Part # by Model Continued

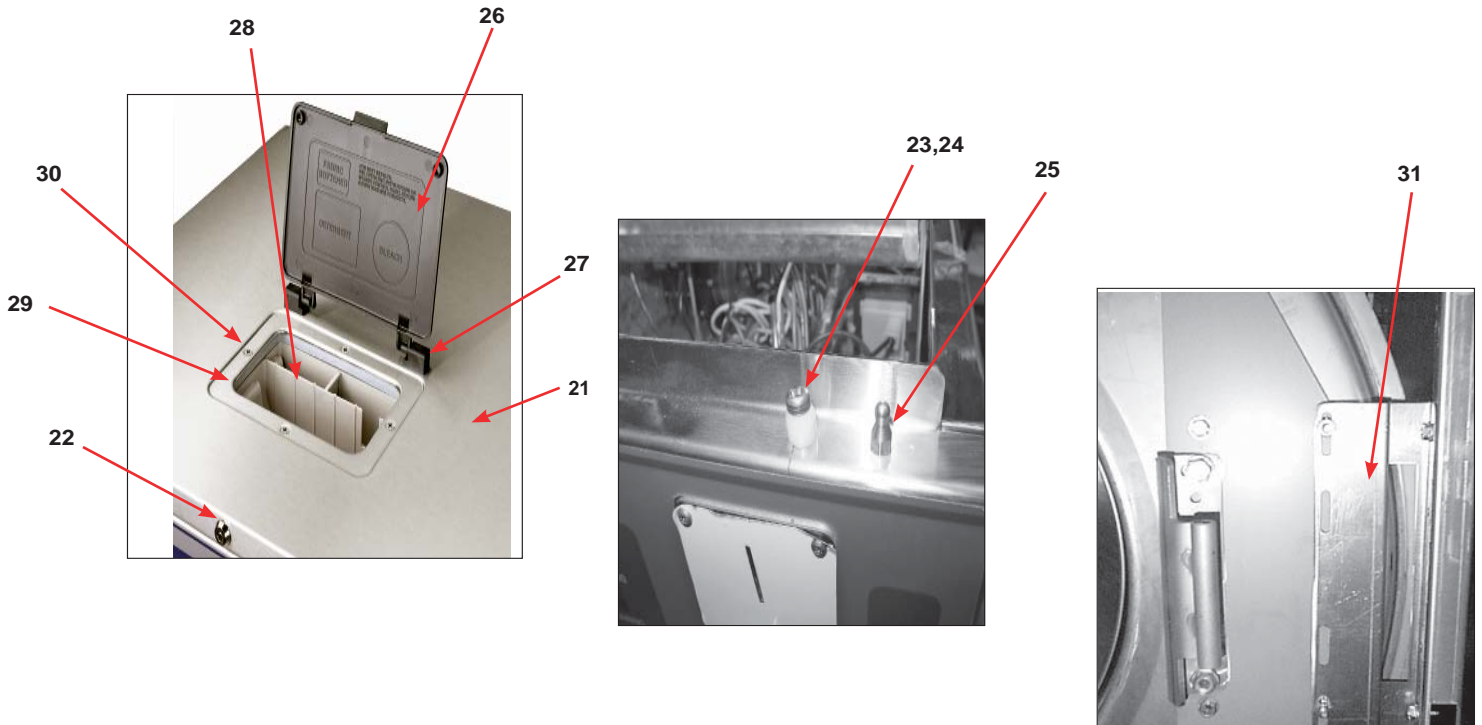

Key	Description	T-300	T-350	T-400	T-450	T-600	QTY
21	Panel Top, Assembly (includes catch)	9989-498-001	9989-498-002	9989-498-003	9989-498-004	9989-498-005	1
*	Catch, Top Panel	9086-017-001	9086-017-001	9086-017-001	9086-017-001	9086-017-001	2
*	Rivit-Catch, Top Panel	8638-190-009	8638-190-009	8638-190-009	8638-190-009	8638-190-009	4
22	Lock, Top (w/Key)	8650-012-003	8650-012-003	8650-012-003	8650-012-003	8650-012-003	1
*	Key, Top- # 6324	6292-006-007	6292-006-007	6292-006-007	6292-006-007	6292-006-007	1
*	Cam, Lock-Top	9095-038-001	9095-038-001	9095-038-001	9095-038-001	9095-038-001	1
*	Nut, 9/32 - 28 Hex	8640-426-001	8640-426-001	8640-426-001	8640-426-001	8640-426-001	1
*	Washer Flat 5/16	8641-581-008	8641-581-008	8641-581-008	8641-581-008	8641-581-008	1
23	Screw, Locator	9545-008-023	9545-008-023	9545-008-023	9545-008-023	9545-008-023	2
24	Plastic Sleeve, Locator	9355-001-001	9355-001-001	9355-001-001	9355-001-001	9355-001-001	2
25	Locator Post	9467-024-001	9467-024-001	9467-024-001	9467-024-001	9467-024-001	2
*	Nut, Locator Post	8640-411-003	8640-411-003	8640-411-003	8640-411-003	8640-411-003	2
26	Door, Dispenser	9108-095-005	9108-095-005	9108-095-005	9108-095-005	9108-095-005	1
27	Post, Door Mounting	9467-025-001	9467-025-001	9467-025-001	9467-025-001	9467-025-001	2
*	Pin, Plain-SS	9451-191-001	9451-191-001	9451-191-001	9451-191-001	9451-191-001	2
*	Screw, Disp.Post Mtg	9545-045-002	9545-045-002	9545-045-002	9545-045-002	9545-045-002	4
28	Dispenser, Soap	9122-005-004	9122-005-004	9122-005-004	9122-005-004	9122-005-004	1
29	Gasket, Dispenser	9206-416-001	9206-416-001	9206-416-001	9206-416-001	9206-416-001	1
*	Nut, Spring-SS	8640-399-007	8640-399-007	8640-399-007	8640-399-007	8640-399-007	4
30	Screw, Disp. Mtg	9545-008-012	9545-008-012	9545-008-012	9545-008-012	9545-008-012	4
*	Flow Restrictor	9475-002-002	9475-002-002	9475-002-002	9475-002-002	9475-002-002	2
*	Plastic Plug 1 1/2"-(inside cylinder)	9456-041-007	9456-041-007	9456-041-007	9456-041-007	9456-041-007	1
31	Bracket, Side Panel under front panel	9029-066-001	9029-066-001	9029-165-001	9029-165-001	9029-165-001	1



## Rear View Access Part # by Model

Key	Description	T-300	T-350	T-400	T-450	T-600	QTY
1	Drive Motor, 3 Phase (Inverter duty)	9732-127-011	9732-227-001	9732-127-012	9732-127-014	9732-127-012	1
	Drive Motor After Serial #483620	9732-225-001					
4	Pulley, Motor	9453-169-012	9453-180-001	9453-170-003	9453-181-001	9453-170-003	1
*	Set Screw,Sq.Hd(motor pulley)	9545-028-015	9545-028-015	9545-028-015	9545-028-015	9545-028-015	2
2	Rod, Motor Mtg	9497-222-002	9497-222-002	9497-222-002	9497-222-002	9497-222-004	1
*	Screw (end of motor rod)	9545-029-005	9545-029-005	9545-029-005	9545-029-005	9545-029-005	1
*	Lockwasher (end of motor rod)	8641-582-014	8641-582-014	8641-582-014	8641-582-014	8641-582-014	1
3	Collar, Shaft (w/set screws) removed starting #530726	9076-052-002	9076-052-002	9076-052-002	9076-052-002	9076-052-002	2
*	Motor Bushing (plastic)Before Serial # 530726	9053-074-002	9053-074-002	9053-074-002	9053-074-002	9053-074-002	2
*	Motor Bushing (Rubber) after Serial # 530726	9053-082-001	9053-082-001	9053-082-001	9053-082-001	9053-082-001	2
*	Clamp-Worm, 316SS, 1.5" (for Rubber bushing) Start #530726	8654-117-019	8654-117-019	8654-117-019	8654-117-019	8654-117-019	2
18	Strap Bracket, Motor Tension	9029-206-002	9029-206-001	9029-206-002	9029-206-002	9029-206-002	1
19	Nut, Strap to Motor 10/32 UNF	8640-413-002	8640-413-002	8640-413-002	8640-413-002	8640-413-002	1
19	Washer #10	8641-581-006	8641-581-006	8641-581-006	8641-581-006	8641-581-006	1
20	Spring, Belt Tension	9534-319-002	9534-319-002	9534-319-002	9534-319-002	9534-319-002	1
5	Pulley, Driven	9908-041-002	9453-168-005	9453-168-004	9453-168-006	9453-168-003	1
*	Tolerance Ring driven pulley	9487-234-002	9487-234-001	9487-234-001	9487-234-003	9487-234-003	1
6	Screw 1/2-13x1 1/4"	9545-017-009	9545-017-009	9545-017-009			1
6	Screw 5/8-11x1 1/2" Driven pulley				9545-060-001	9545-060-001	1
6	Lockwasher 1/2"	8641-582-016	8641-582-016	8641-582-016			1
6	Lockwasher 5/8"				8641-582-018	8641-582-018	1
7	Washer, Flat 1/2"	8641-581-026	8641-581-026	8641-581-026			1
7	Washer, Flat 5/8x2 1/4"				8641-581-032	8641-581-032	1
8	Drive Belt	9040-076-004	9040-079-004		9040-079-005		1
8	Drive Belt			9040-076-005		9040-076-005	2
9	Channel, Rear	9081-132-001	9081-132-001	9081-135-001	9081-135-001	9081-134-001	1
*	Screw Mtg rear channel	9545-008-026	9545-008-026	9545-008-026	9545-008-026	9545-008-026	4
*	Nut, Spring Rear Channel MTG	8640-399-008	8640-399-008	8640-399-008	8640-399-008	8640-399-008	4
23	VFD Delta "S" drive 120 volt	9375-019-002					1
23	VFD Delta "S" drive 208-240 volt	9375-016-003	9375-015-010	9375-015-006	9375-015-012	9375-015-008	1
24	Braking resistors (200 ohm)	9483-004-002					1
24	Braking resistors (200 ohm)		9483-004-002	9483-004-002	9483-004-002	9483-004-002	2
24	Braking resistors (160 ohm)						2
25	Bracket assembly (drive mounting)	9985-157-001	9029-157-001	9985-157-001	9985-157-001	9985-157-001	1
31	Terminal Block Channel Mount			9897-033-002	9897-033-002	9897-033-002	1
	Screw to Mtg Brake Resistor	9545-012-008	9545-012-008	9545-012-008	9545-012-008	9545-012-008	4
	Nut 10-32 Mtg Brake Resistor	8640-413-002	8640-413-002	8640-413-002	8640-413-002	8640-413-002	4
	Drive Cover Plate			9074-267-001		9074-278-001	



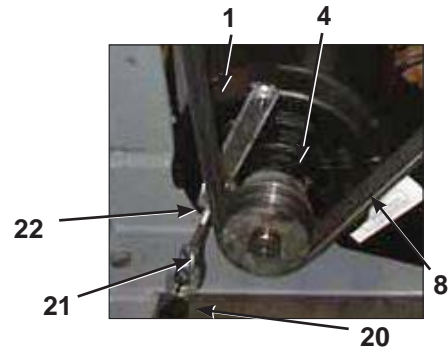
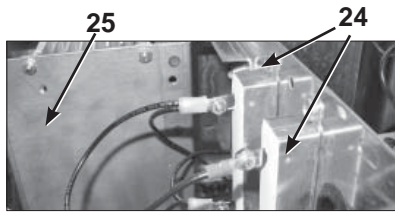
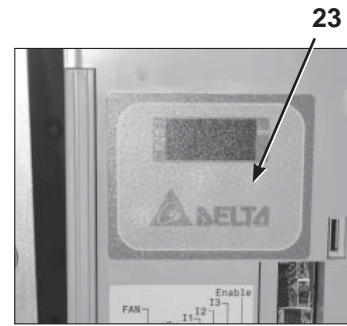
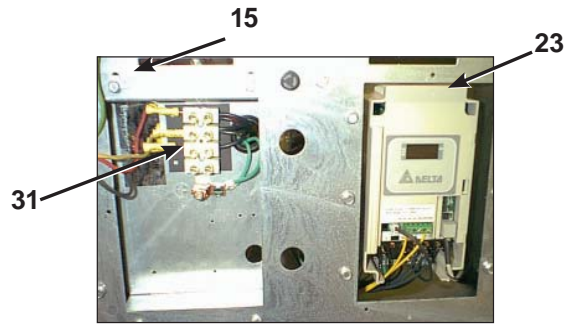
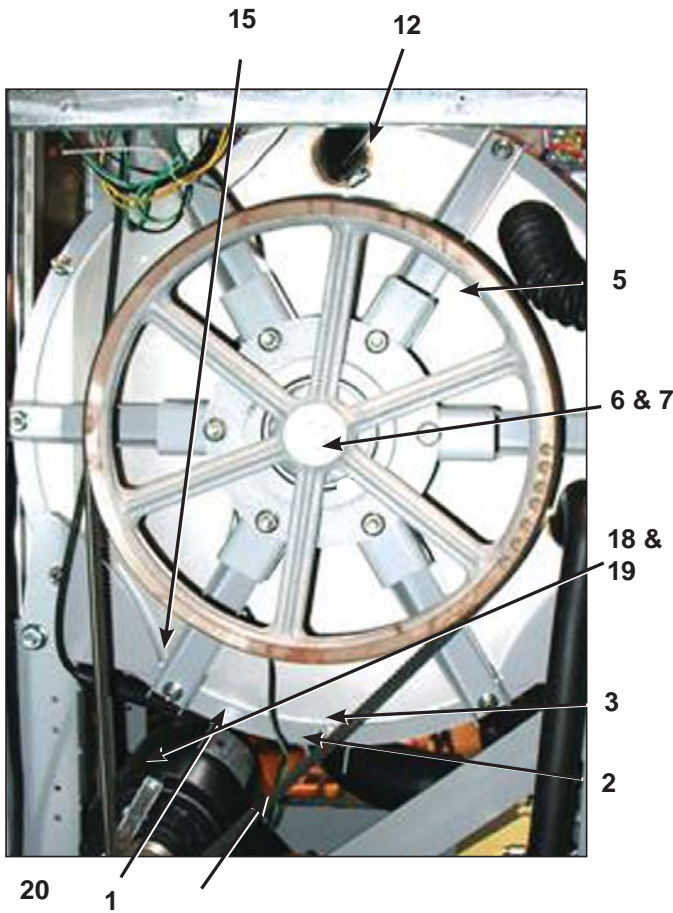

Key	Description	T-300	T-350	T-400	T-450	T-600	QTY
12	Hose, Overflow Vent Top	9242-463-001	9242-463-002	9242-463-002	9242-463-003	9242-463-003	
12	Clamp, Hose Vent	8654-117-008	8654-117-008	8654-117-008	8654-117-008	8654-117-008	2
11	Hose, Overflow to drain	9242-449-002	9242-449-002	9242-449-002	9242-449-002	9242-449-002	1
11	Clamp, Hose overflow to drain	8654-117-018	8654-117-018	8654-117-018	8654-117-018	8654-117-018	2
15	Hose, Pressure Switch	9242-175-000	9242-175-000	9242-175-007	9242-175-007	9242-175-001	1
*	Clamp, Pressure Switch Hose	8654-117-015	8654-117-015	8654-117-015	8654-117-015	8654-117-015	1
	Vacuum Breaker Mtg Bracket	9029-065-001	9029-065-001	9029-065-001	9029-077-001	9029-077-001	1
13	Vacuum Breaker ALL	9610-001-001	9610-001-001	9610-001-001	9610-001-001	9610-001-001	1
*	Clamp, Hose to Vacuum Breaker	8654-117-014	8654-117-008	8654-117-008	8654-117-014	8654-117-014	1
16	Hose, Vacuum Breaker to tub	9242-458-001	9242-458-001	9242-458-002	9242-458-002	9242-458-002	1
14	Plastic Plug 7/8" Electrical Connection	9456-041-006	9456-041-006	9456-041-006	9456-041-006	9456-041-006	2
*	Panel Assy., Back	9454-632-001	9989-632-001	9989-446-002	9989-446-002	9989-446-001	1
*	Screw Panel Mtg.#10Bx1/2"	9545-008-026	9545-008-026	9545-008-026	9545-008-026	9545-008-026	10
*	Nut, Spring	8640-399-004	8640-399-004	8640-399-004	8640-399-008	8640-399-008	6
*	Screw, To Base-1/4x3/4	9545-008-026	9545-008-026	9545-008-026	9545-030-002	9545-030-002	1

## Cylinder, Seals & Bearings Part # by Model

Key	Description	T-300	T-350	T-400	T-450	T-600	QTY
*	Bearing Kit (Includes 2-10)	9732-219-001	9732-219-002	9732-219-002	9732-219-004	9732-219-004	
*	Housing, Bearing- Assembly (items #2-#6)	9803-182-001	9803-179-003	9803-179-002	9803-186-001	9803-186-001	1
2	Housing, Bearing	9241-174-002	9241-169-002	9241-169-002	9241-180-002	9241-180-002	1
3	Bearing, Front (LARGE)	9036-159-001	9036-159-009	9036-159-002	9036-159-005	9036-159-005	1
4	Bearing, Rear (SMALL)	9036-159-003	9036-159-008	9036-159-001	9036-159-004	9036-159-004	1
5	Spacer, Bearing	9538-161-001	9538-158-001	9538-158-001	9538-167-001	9538-167-001	1
6	Ring, Bearing Retainer	9487-238-002	9487-238-001	9487-238-001	9487-238-003	9487-238-003	1
7	Tub Back Mating Ring	9487-261-001	9487-261-002	9487-261-002	9487-261-003	9487-261-003	1
8	Seal, Primary	9532-140-004	9532-140-002	9532-140-002	9532-140-002	9532-140-002	1
9	Seal, Secondary	9532-140-005	9532-140-003	9532-140-003	9532-140-006	9532-140-006	1
10	Ring, Seal Mounting	9950-047-001	9950-042-001	9950-042-001	9950-048-001	9950-048-001	1
11	Back Assy, Tub 2 piece	9732-137-001	9732-137-002	9732-137-002	9732-137-003	9732-137-003	1
12	Bolt, Tub End of Bearing Housing (1/2" x 1 1/4")	9545-017-009	9545-017-009	9545-017-009			6
12	Nut 1/2"	8640-417-005	8640-417-005	8640-417-005			6
12	Lockwasher 1/2" (ext. tooth)	8641-581-034	8641-581-034	8641-582-016			6
12	Bolt 5/8-11x1 1/2" Tub end of bearing housing				9545-059-003	9545-059-003	6
12	Nut 5/8"				8640-425-001	8640-425-001	6
13	Support Arm Assy, Bearing Housing	9991-049-002	9991-057-002	9991-061-002	9991-056-002	9991-056-002	6
14	Bolt Pulley End of Bearing Housing (3/8" x 1 1/2")	9545-029-003	9545-029-003	9545-029-003			6
14	Nut, Flange Locking 3/8"	9640-415-004	8640-415-004	8640-415-004			6
14	Bolt Pulley end of bearing housing (7/16-14x2")				9545-059-002	9545-059-002	6
14	Nut, Flange Locking 7/16"				8640-416-005	8640-416-005	6
15	Pulley, Driven	9908-041-002	9453-168-005	9453-168-004	9453-168-006	9453-168-003	1
*	Ring, Tolerance	9487-234-002	9487-234-001	9487-234-001	9487-234-003	9487-234-003	1
16	Washer 1/2"	8641-581-026	8641-581-026	8641-581-026			1
16	Washer 5/8"				8641-581-032	8641-581-032	1
18	Bolt 1/2-13 x 1 1/4"	9545-017-009	9545-017-009	9545-017-009			1
18	Bolt 5/8-11x11/2"				9545-060-001	9545-060-001	1
20	Lockwasher 1/2" Ext. tooth	8641-582-016	8641-582-016	8641-582-016			1
18	Lockwasher 5/8 Ext. tooth				8641-582-018	8641-582-018	1
*	Cylinder Assy	9848-111-001	9848-121-001	9848-109-001	9848-123-001	9848-113-001	1
*	Tub and Cylinder Assy.	9869-006-001	9869-013-002	9869-021-001	9869-014-001	9869-017-001	1
*	Tub Assembly	9930-135-001	9930-143-001	9930-152-001	9930-142-001	9930-146-001	1

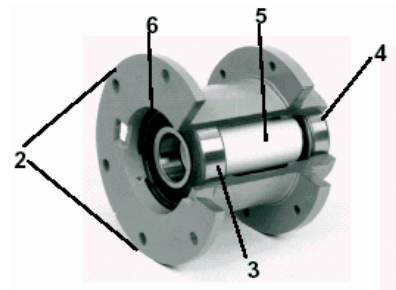
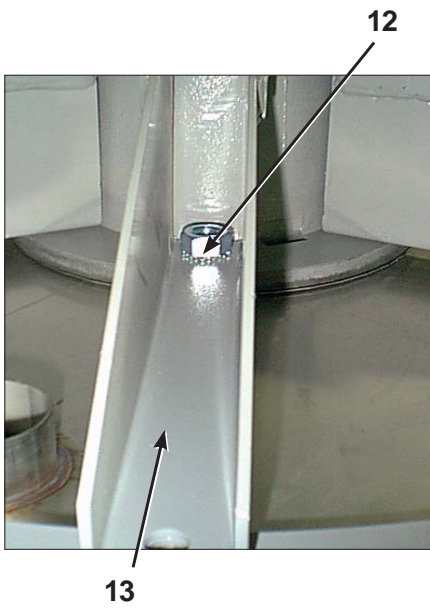
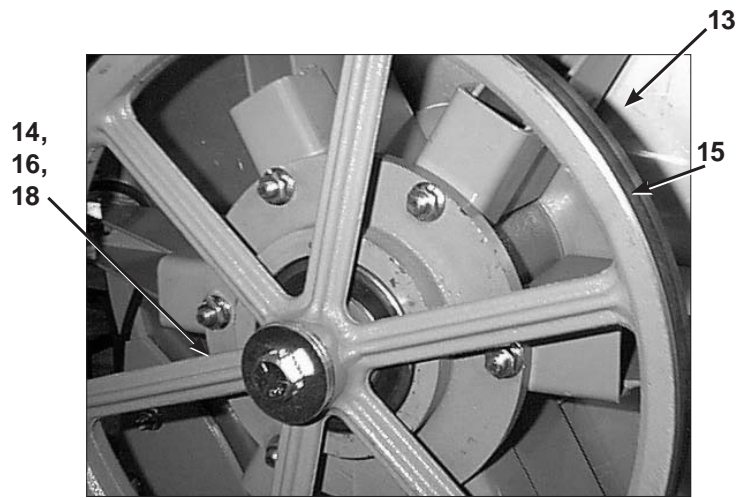
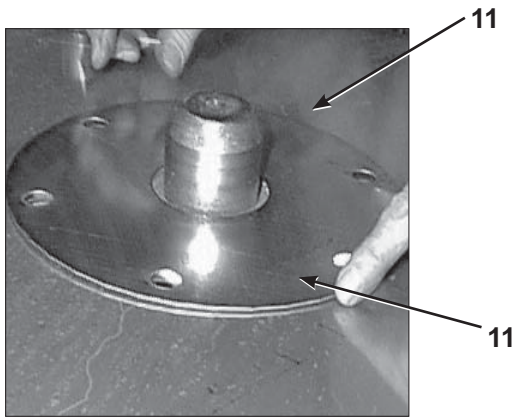
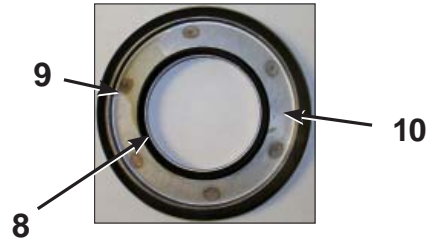
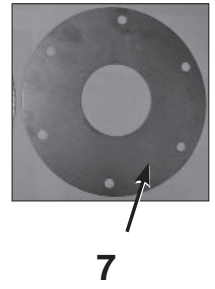
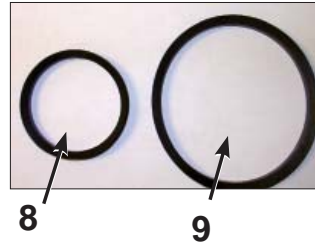
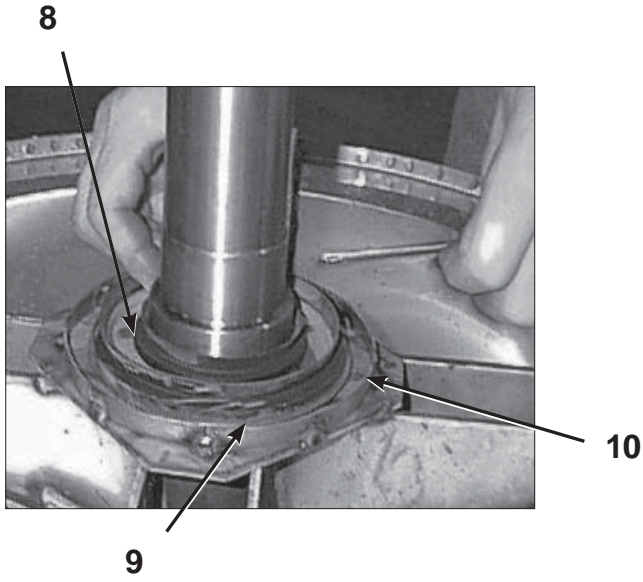

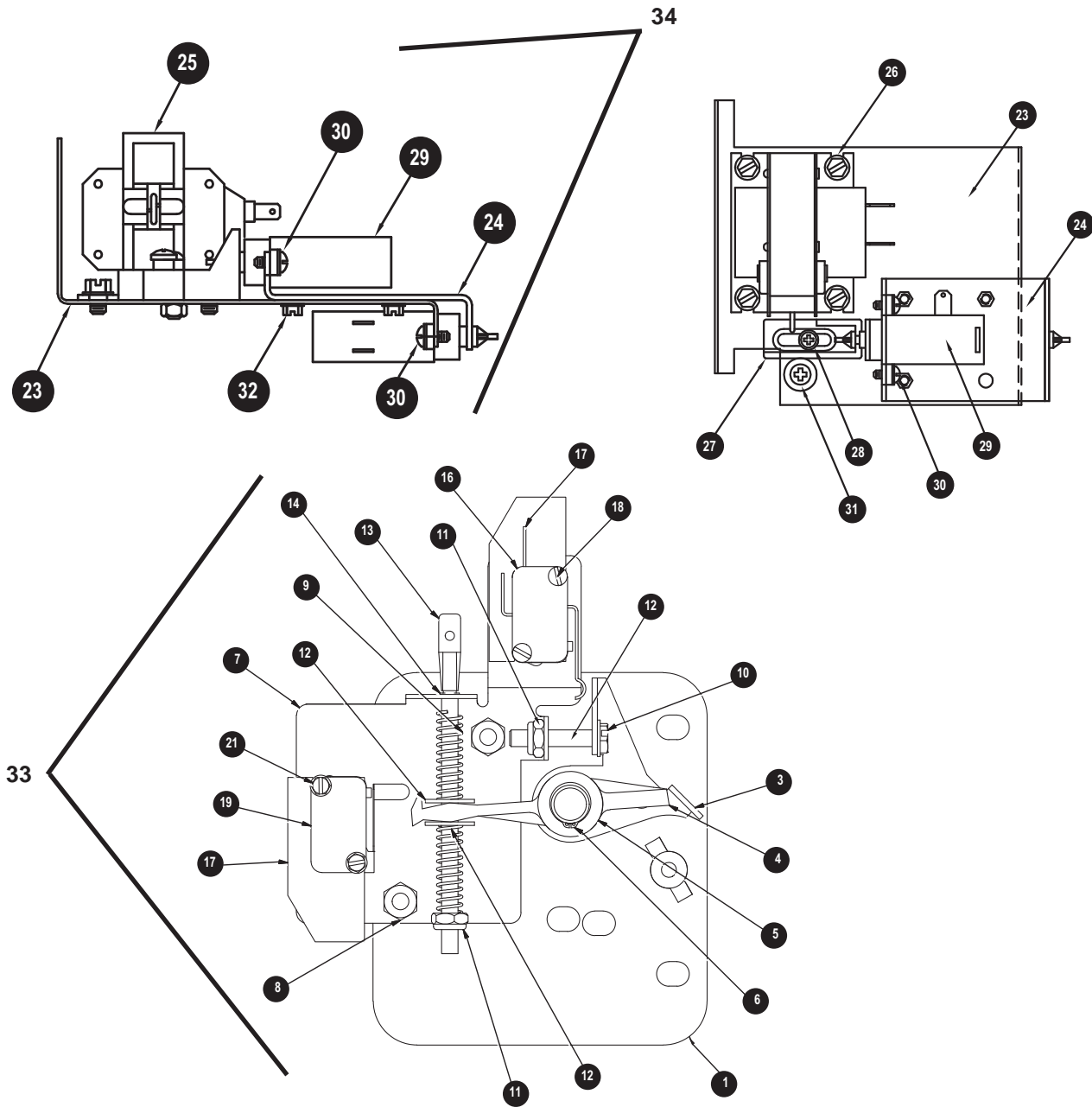

Door Lock Part # by Model

Key	Description	T-300	T-350	T-400	T-450	T-600	QTY
33	Lock Assy, Complete (#1-22) (includes #1 thru #22)	9885-024-001	9885-024-001	9885-024-001	9885-024-001	9885-024-001	1
1	Plate Assy, Door Lock	9982-346-001	9982-346-001	9982-346-001	9982-346-001	9982-346-001	1
2	Washer, Flat	8641-581-030	8641-581-030	8641-581-030	8641-581-030	8641-581-030	1
3	Actuator, Latching Switch	9008-005-001	9008-005-001	9008-005-001	9008-005-001	9008-005-001	1
4	Pawl, Locking	9450-002-004	9450-002-004	9450-002-004	9450-002-004	9450-002-004	1
5	Washer, Spring	8641-569-003	8641-569-003	8641-569-003	8641-569-003	8641-569-003	1
6	Ring, Retaining	9487-200-004	9487-200-004	9487-200-004	9487-200-004	9487-200-004	1
7	Bracket Switch	9029-163-001	9029-163-001	9029-163-001	9029-163-001	9029-163-001	1
8	Nut, Hex 10-32 UNF	8640-413-002	8640-413-002	8640-413-002	8640-413-002	8640-413-002	2
9	Spring, Actuating	9534-364-002	9534-364-002	9534-364-002	9534-364-002	9534-364-002	1

## Original Solenoid Style Door Lock Part # by Model (continued)

Key	Description	T-300	T-350	T-400	T-450	T-600	QTY
10	Screw, Hx. 10-32 x 1"	9545-012-020	9545-012-020	9545-012-020	9545-012-020	9545-012-020	1
11	Nut, Elastic Stop 10-32	8640-413-004	8640-413-004	8640-413-004	8640-413-004	8640-413-004	2
12	Spring, Return	9534-364-001	9534-364-001	9534-364-001	9534-364-001	9534-364-001	2
13	Pin, Guide	9451-193-001	9451-193-001	9451-193-001	9451-193-001	9451-193-001	1
14	Ring, Retaining	9487-200-005	9487-200-005	9487-200-005	9487-200-005	9487-200-005	1
15	Washer	8641-581-031	8641-581-031	8641-581-031	8641-581-031	8641-581-031	1
16	Switch, Latching Sensing	9539-461-008	9539-461-008	9539-461-008	9539-461-008	9539-461-008	1
17	Shield, Switch	9550-169-003	9550-169-003	9550-169-003	9550-169-003	9550-169-003	3
18	Screw 4-40 x 5/8"	9545-020-001	9545-020-001	9545-020-001	9545-020-001	9545-020-001	2
18	Nut, Twin	8640-401-001	8640-401-001	8640-401-001	8640-401-001	8640-401-001	1
19	Switch, Locking Sensing	9539-461-007	9539-461-007	9539-461-007	9539-461-007	9539-461-007	2
20	Actuator, Switch Locking	9008-006-003	9008-006-003	9008-006-003	9008-006-003	9008-006-003	1
21	Screw 4-40 x 1 1/8"	9545-020-003	9545-020-003	9545-020-003	9545-020-003	9545-020-003	2
21	Nut, Twin 4-40	8640-401-001	8640-401-001	8640-401-001	8640-401-001	8640-401-001	1
22	Pin, Dowel	9451-181-004	9451-181-004	9451-181-004	9451-181-004	9451-181-004	1
*	Shim, Door Lock, Thin	9552-037-001	9552-037-001	9552-037-001	9552-037-001	9552-037-001	AR
*	Screw, Lock mtg 1/4"-20 x 3/4"	9545-018-004	9545-018-004	9545-018-004	9545-018-004	9545-018-004	3
*	Lockwasher 1/4" Ext tooth	8641-582-007	8641-582-007	8641-582-007	8641-582-007	8641-582-007	3
34	Solenoid Ass'y, Door Locking (includes 23 thru 32)	9922-011-001	9922-011-001	9922-011-001	9922-011-001	9922-011-001	1
23	Bracket, (Door Locking Solenoid)	9029-073-001	9029-073-001	9029-073-001	9029-073-001	9029-073-001	1
24	Bracket Ass'y, Solenoid Slide	9985-169-001	9985-169-001	9985-169-001	9985-169-001	9985-169-001	1
25	Solenoid 120V 60 hz	9536-074-001	9536-074-001	9536-074-001	9536-074-001	9536-074-001	1
26	Screw, Solenoid Mtg	9545-008-001	9545-008-001	9545-008-001	9545-008-001	9545-008-001	4
27	Stop, Door Lock Solenoid	9540-036-002	9540-036-002	9540-036-002	9540-036-002	9540-036-002	1
28	Screw, Shoulder	9545-061-001	9545-061-001	9545-061-001	9545-061-001	9545-061-001	1
28	Nut, Keps #6	8640-411-002	8640-411-002	8640-411-002	8640-411-002	8640-411-002	1
29	Thermoactuator 120 V	9586-001-001	9586-001-001	9586-001-001	9586-001-001	9586-001-001	2
30	Screw #6 x 5/16"	9545-031-011	9545-031-011	9545-031-011	9545-031-011	9545-031-011	4
31	Spacer, Plastic	9538-157-004	9538-157-004	9538-157-004	9538-157-004	9538-157-004	1
31	Spacer, Metal	9538-166-004	9538-166-004	9538-166-004	9538-166-004	9538-166-004	1
31	Screw, Cross Recessed	9545-010-001	9545-010-001	9545-010-001	9545-010-001	9545-010-001	1
31	Nut, Keps #8	8640-412-005	8640-412-005	8640-412-005	8640-412-005	8640-412-005	1
*	Nut, Sol. Brkt. to Control Panel	8640-412-005	8640-412-005	8640-412-005	8640-412-005	8640-412-005	3
*	Rod, Pull	9497-225-004	9497-225-004	9497-225-006	9497-225-006	9497-225-003	1

# Gear Motor Door Lock Assembly

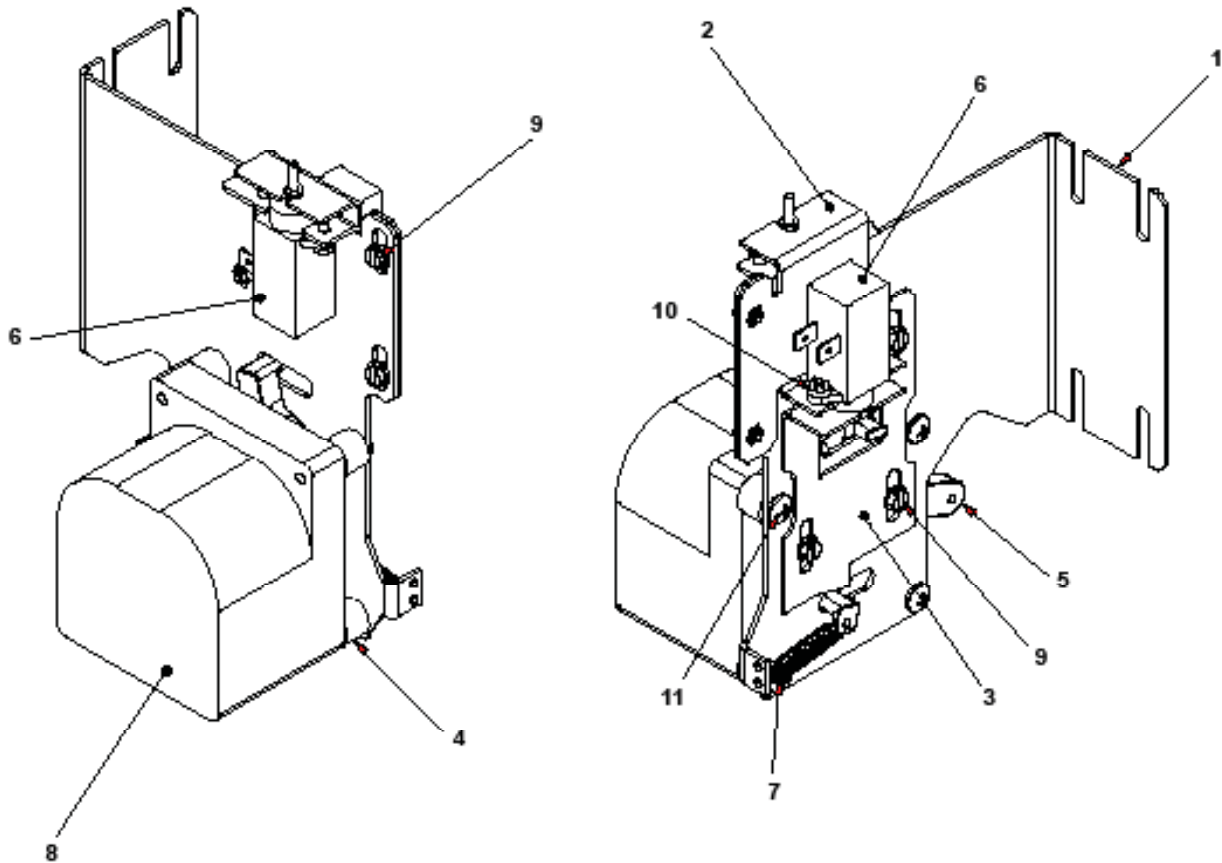

Key	Description	T-300	T-350	T-400	T-450	T-600	QTY
*	Actuator Assembly (Includes 1-10, Rod NOT included)	9892-014-001	9892-014-001	9892-014-001	9892-014-001	9892-014-001	1
11	Screw Pnhdcr, 10-32 UNFx0 .75	9545-012-027	9545-012-027	9545-012-027	9545-012-027	9545-012-027	4
10	Cross Recessed PAn Hd Tapping screw	9545-031-011	9545-031-011	9545-031-011	9545-031-011	9545-031-011	4
9	Screw -Hxwshrhdslsems, 6-32 x 3/16	9545-044-003	9545-044-003	9545-044-003	9545-044-003	9545-044-003	6
8	Motor & Gear Assembly 120v	9914-137-011	9914-137-011	9914-137-011	9914-137-011	9914-137-011	1
7	Spring - Extension	9534-350-001	9534-350-001	9534-350-001	9534-350-001	9534-350-001	1
6	Thermoactuator - Door Lock Relay 120v	9586-001-001	9586-001-001	9586-001-001	9586-001-001	9586-001-001	2
5	Arm - Door Lock	9001-063-001	9001-063-001	9001-063-001	9001-063-001	9001-063-001	1
4	Spacer, Plastic	9538-157-021	9538-157-021	9538-157-021	9538-157-021	9538-157-021	4
3	Bracket Slide Lock	9029-204-001	9029-204-001	9029-204-001	9029-204-001	9029-204-001	1
2	Bracket Assy, Slide - Unlock	9985-189-001	9985-189-001	9985-189-001	9985-189-001	9985-189-001	1
1	Bracket Assy, Slide Lock Actuator	9985-190-001	9985-190-001	9985-190-001	9985-190-001	9985-190-001	1
*	Rod, Door Lock	9497-225-011	9497-225-011	9497-225-012	9497-225-012	9497-225-010	1



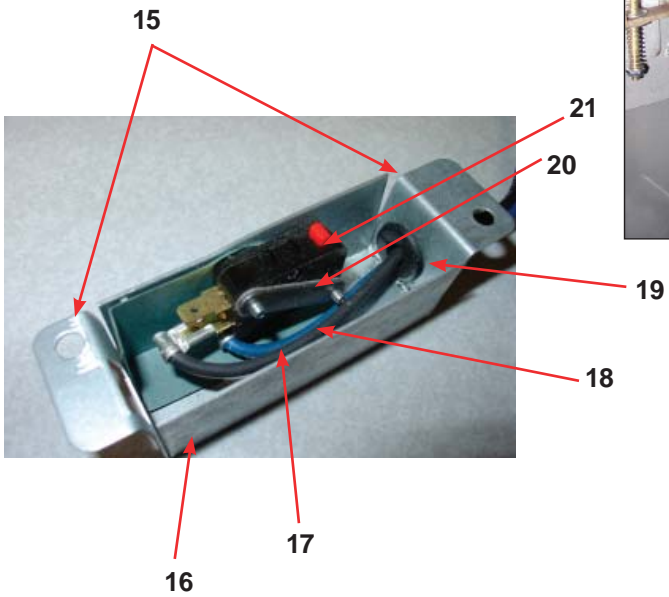
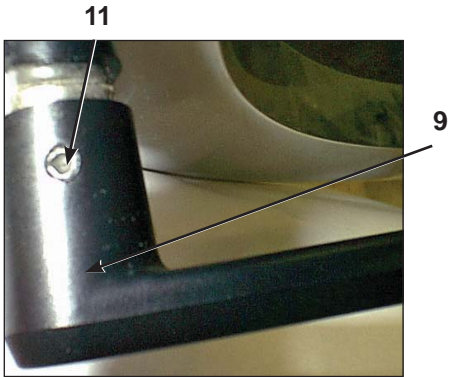
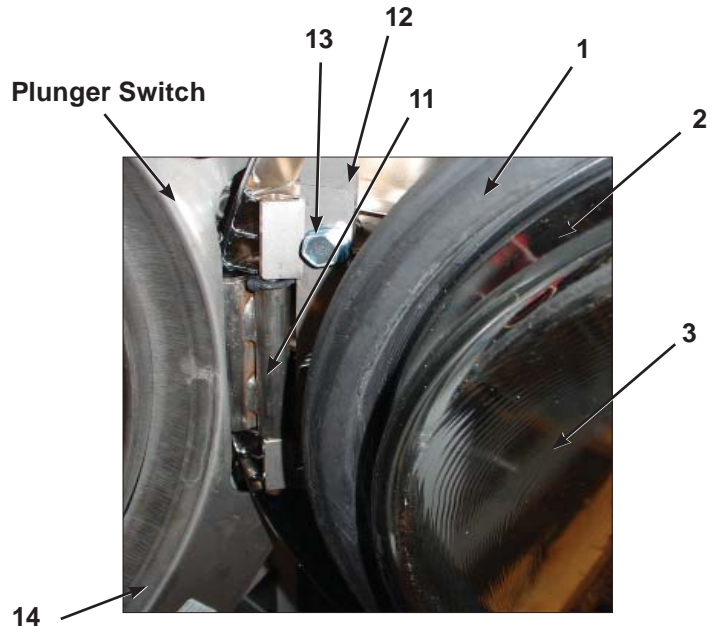
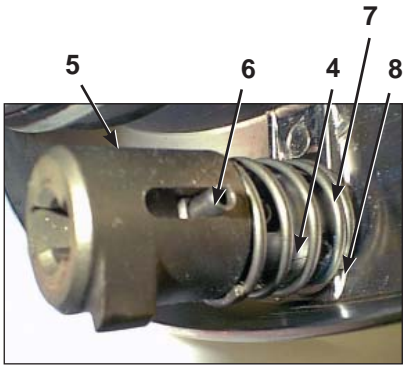



# Loading Door Part # by Model (Original Style Door Switch)

Key	Description	T-300	T-350	T-400	T-450	T-600	QTY
*	Loading Door, Complete #1-10	9960-273-001	9960-273-00	9960-274-002	9960-274-002	9960-274-002	1
1	Loading Door, Ring	9487-264-001	9487-264-001	9487-265-001	9487-265-001	9487-265-001	1
2	Gasket, Loading Door	9206-411-002	9206-411-001	9206-419-001	9206-419-001	9206-419-001	1
3	Window, Loading Door	9635-018-001	9635-018-001	9635-016-001	9635-016-001	9635-016-001	1
*	Shaft Assy, Locking (includes 4 thru 7)	9913-134-003	9913-134-003	9913-134-003	9913-134-003	9913-134-003	1
4	Shaft, Door Locking	9537-195-002	9537-195-002	9537-195-002	9537-195-002	9537-195-002	1
5	Cam, Locking	9095-040-002	9095-040-002	9095-040-002	9095-040-002	9095-040-002	1
6	Pin, Groove (1 1/4)	9451-181-005	9451-181-005	9451-181-005	9451-181-005	9451-181-005	1
7	Pin, Groove (3/4)	9451-181-004	9451-181-004	9451-181-004	9451-181-004	9451-181-004	1
	Retaining Ring (c-clip)	8649-031-002	8649-031-002	8649-031-002	8649-031-002	8649-031-002	1
8	Spring, Lock Cam	9534-360-002	9534-360-002	9534-360-002	9534-360-002	9534-360-002	1
9	Handle, Door	9244-080-003	9244-080-003	9244-080-003	9244-080-003	9244-080-003	1
11	Pin, Door Handle (groove)	9451-181-006	9451-181-006	9451-181-006	9451-181-006	9451-181-006	1
*	Screw, Hinge Mtg 5/16" x 3/4"	9545-014-009	9545-014-009	9545-014-009	9545-014-009	9545-014-009	3
*	Lockwasher 5/16" Ext tooth	8641-582-009	8641-582-009	8641-582-009	8641-582-009	8641-582-009	3
*	Shim, Loading Door Hinge, Thin	9552-036-001	9552-036-001	9552-036-001	9552-036-001	9552-036-001	AR
10	Door Hinge Assembly Mounts to Tub Front	9955-029-002	9955-029-002	9955-029-002	9955-029-002	9955-029-002	1
13	Screw, Loading Door Mtg (5/16" TF)	9545-056-001	9545-056-001	9545-056-001	9545-056-001	9545-056-001	3
*	Rubber Edge (mounts to Front Panel)	9059-063-004	9059-063-004	9059-063-002	9059-063-002	9059-063-002	1
*	Nut, Keps	8640-413-002	8640-413-002	8640-413-002	8640-413-002	8640-413-002	4
*	Wiring Harness doorlock safety switch assembly	9627-791-003	9627-791-003	9627-791-003	9627-791-003	9627-791-004	1
12	Loading Door Hinge Clamp w/ pin	9938-040-002	9938-040-002	9938-040-002	9938-040-002	9938-040-002	1
*	Loading Door Hinge Clamp (No Hinge Switch Pin) (NEW Style)	9079-122-003	9079-122-003	9079-122-003	9079-122-003	9079-122-003	1
14	Masking-Ring	9950-059-001	9950-059-001	9950-060-001	9950-060-001	9950-060-001	1
*	Nut, Keps #10-32 UNF	8640-413-002	8640-413-002	8640-413-002	8640-413-002	8640-413-002	4
15	Switch Assembly Complete Door Close	9801-089-001	9801-089-001	9801-089-001	9801-089-001	9801-089-001	1
16	Switch Box	9041-087-001	9041-087-001	9041-087-001	9041-087-001	9041-087-001	1
17	Black Wire Door Close Switch	8220-063-026	8220-063-026	8220-063-026	8220-063-026	8220-063-026	1
18	Blue Wire Door Close Switch	8220-063-025	8220-063-025	8220-063-025	8220-063-025	8220-063-025	1
19	Bushing Insulating	9053-067-003	9053-067-003	9053-067-003	9053-067-003	9053-067-003	1
20	Nut Special Twin #4-40	8640-401-001	8640-401-001	8640-401-001	8640-401-001	8640-401-001	1
*	Screw 4-40 x 5/8	9545-020-001	9545-020-001	9545-020-001	9545-020-001	9545-020-001	2
*	Nut, Keps #10-32 UNF	8640-413-002	8640-413-002	8640-413-002	8640-413-002	8640-413-002	2
*	Door Switch Actuator	9008-004-001	9008-004-001	9008-004-001	9008-004-001	9008-004-001	1
21	Switch,Door Hinge Close	9539-461-007	9539-461-007	9539-461-007	9539-461-007	9539-461-007	1

## Loading Door Hinge (Newer Style Door Switch) With No Pin On Clamp Or Leaf

Key	Description	T-300	T-350	T-400	T-450	T-600
1	Door Hinge Assembly (mounts to tub front)	9955-029-002	9955-029-002	9955-029-002	9955-029-002	9955-029-002
2	Loading Door Hinge Pin	9781-001-001	9781-001-001	9781-001-001	9781-001-001	9781-001-001
3	Loading Door Hinge Clamp (No Hinge Switch Pin)	9079-122-003	9079-122-003	9079-122-003	9079-122-003	9079-122-003
4	Masking Ring Assembly (For Newer Plunger Switch)	9487-272-001	9487-272-001	9487-273-001	9487-273-001	9487-273-001
5	Red Wire (Door Close Switch)	8220-063-025	8220-063-025	8220-063-025	8220-063-025	8220-063-025
9	Black Wire (Door Close Switch)	8220-063-026	8220-063-026	8220-063-026	8220-063-026	8220-063-026
10	Switch, Door Hinge Close (Plunger)	9539-492-001	9539-492-001	9539-492-001	9539-492-001	9539-492-001
11	Masking Ring	9487-272-001	9487-273-001	9487-273-001	9487-273-001	9487-273-001

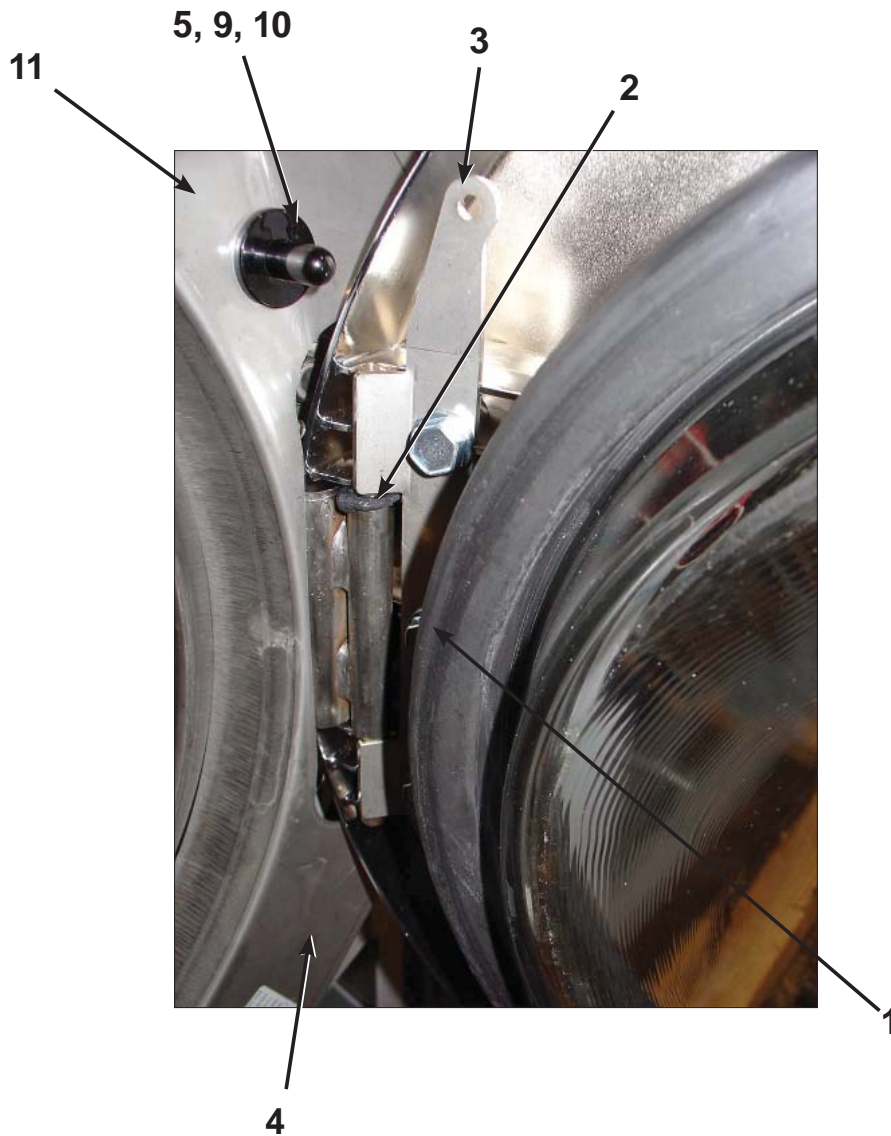

# Water Inlet Valve Breakdown Part # by Model

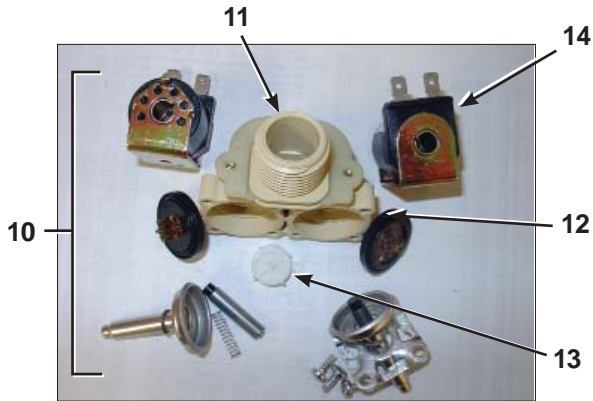

**Mueller Valve**

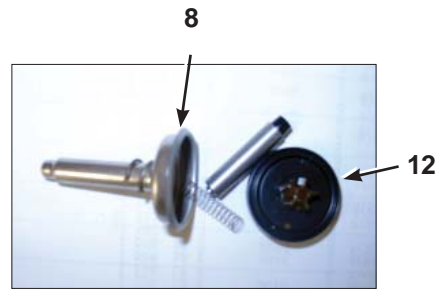

**Mueller Diaphragm**

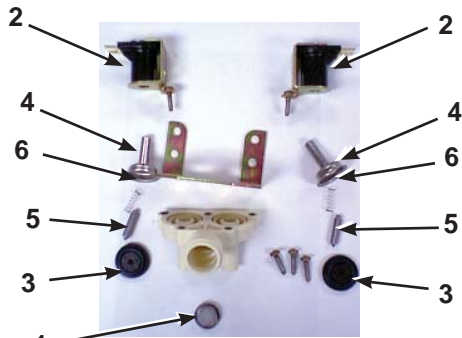

**Invensys Valve**

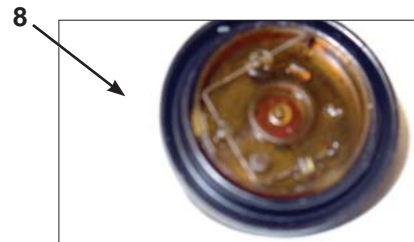

**Mueller Diaphragm**

Key	Description	T-300	T-350	T-400	T-450	T-600	QTY
*	Valve, Water Inlet (includes 1 thru 6)	9379-183-003	9379-183-003	9379-183-003	9379-183-003	9379-183-003	2
1	Screen, Inlet end of valve	9555-056-001	9555-056-001	9555-056-001	9555-056-001	9555-056-001	2
2	Coil Assy., 120 V Invensys	9089-017-001	9089-017-001	9089-017-001	9089-017-001	9089-017-001	2
3	Diaphragm Invensys	9118-049-001	9118-049-001	9118-049-001	9118-049-001	9118-049-001	2
4	Guide, Solenoid Invensys	9211-021-002	9211-021-002	9211-021-002	9211-021-002	9211-021-002	2
5	Armature Invensys	9015-008-001	9015-008-001	9015-008-001	9015-008-001	9015-008-001	2
6	Spring, Armature Invensys	9534-298-001	9534-298-001	9534-298-001	9534-298-001	9534-298-001	2

Key	Description	T-300	T-350	T-400	T-450	T-600	QTY
10	Dual Coil Water Valve Mueller	9379-192-001	9379-192-001	9379-192-001	9379-192-001	9379-192-001	2
11	Valve Water Body Complete (no coil)	9379-192-002	9379-192-002	9379-192-002	9379-192-002	9379-192-002	
12	Diaphragm Mueller	9118-054-001	9118-054-001	9118-054-001	9118-054-001	9118-054-001	
13	Filter Mueller	9183-046-001	9183-046-001	9183-046-001	9183-046-001	9183-046-001	
14	Coil Mueller	9089-051-001	9089-051-001	9089-051-001	9089-051-001	9089-051-001	
16	Diaphragm Assembly Mueller	9785-001-001	9785-001-001	9785-001-001	9785-001-001	9785-001-001	

Key	Description	T-300	T-350	T-400	T-450	T-600	QTY
*	Dual Coil Water Valve Elbie	9379-191-001	9379-191-001	9379-191-001	9371-192-001	9379-191-001	2
*	Kit, Elbie water Valve w/bracket	9732-195-001	9732-195-001	9732-195-001	9732-195-001	9732-195-001	2

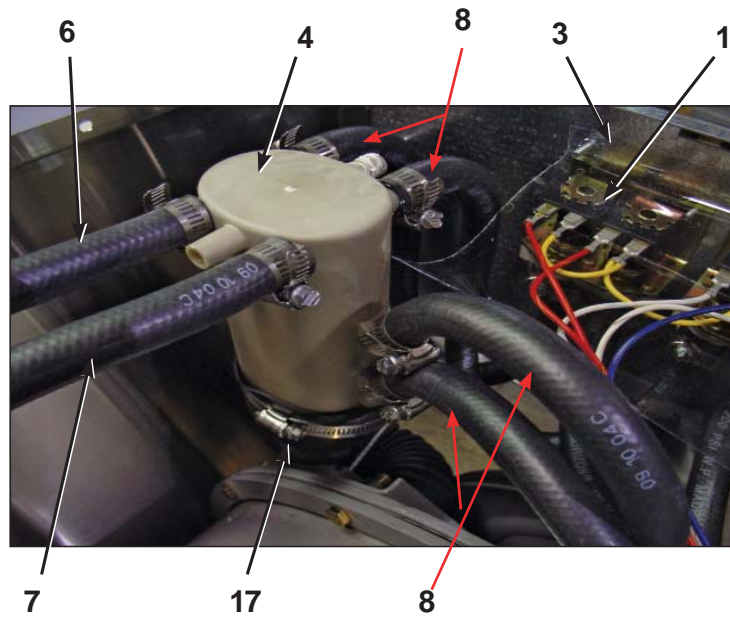
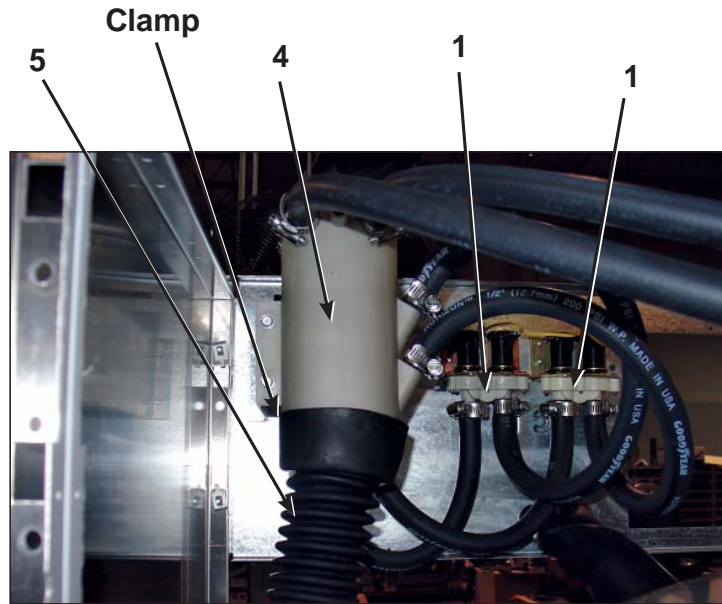

## Water Inlet Part # by Model

Key	Description	T-300	T-350	T-400	T-450	T-600	QTY
1	Valve, Water Inlet (dual outlet) (see Water Inlet Valve Break-down for individual parts)	9379-183-003	9379-183-003	9379-183-003	9379-183-003	9379-183-003	2
*	Screw, Valve Mtg	9545-008-026	9545-008-026	9545-008-026	9545-008-026	9545-008-026	4
*	Nut, Spring	8640-399-009	8640-399-009	8640-399-009	8640-399-009	8640-399-009	4
*	Screw, Valve M4x0.7x8mm						8
4	Vacuum Breaker	9610-001-001	9610-001-001	9610-001-001	9610-001-001	9610-001-001	1
*	Bracket, Vacuum Breaker	9029-065-001	9029-065-001	9029-065-001	9029-077-001	9029-077-001	1
*	Screw	9545-008-026	9545-008-026	9545-008-026	9545-008-026	9545-008-026	4
3	Shield over Water Valves Plastic	9550-186-001	9550-186-001	9550-186-001	9550-186-001	9550-186-001	1
5	Hose, Vacuum Breaker to Tub	9242-458-001	9242-458-001	9242-458-002	9242-458-002	9242-458-002	1
*	Clamp, Tub End	8654-117-009	8654-117-009	8654-117-009	8654-117-009	8654-117-009	1
8	Hose, Valve to Vac. Braker	9242-453-020	9242-453-020	9242-453-020	9242-453-020	9242-453-020	4
7	Hose, Cold, Vac. Brkr. dispenser	9242-453-015	9242-453-015	9242-453-016	9242-453-016	9242-453-009	1
6	Hose, Hot, Vac. Brkr. dispenser	9242-453-016	9242-453-016	9242-453-017	9242-453-017	9242-453-020	1
*	Clamp, Hose-Worm	8654-117-015	8654-117-015	8654-117-015	8654-117-015	8654-117-015	12
13	Hose, (valve to vac. Brkr) 23"						4
*	Clamp, Hose-Spring (overflow from drain to tub back)	8654-117-018	8654-117-018	8654-117-018	8654-117-018	8654-117-018	2
*	Flow restrictor	9475-002-002	9475-002-002	9475-002-002	9475-002-002	9475-002-002	2
*	Circuit Breaker (optional)	5198-211-004	5198-211-004	5198-211-004	5198-211-004	5198-211-004	1
14	Fuseholder	9200-001-002	9200-001-002	9200-001-002	9200-001-002	9200-001-002	1
15	Fuse 1.5 amp	8636-018-001	8636-018-001	8636-018-001	8636-018-001	8636-018-001	1
16	Hose Tub to Drain Valve	9242-468-001	9242-468-001	9242-456-001	9242-456-001	9242-456-001	1
17	Clamp, Vacuum Breaker End	8654-117-014	8654-117-014	8654-117-014	8654-117-014	8654-117-014	1



16

## Drain Valve Group Part # by Model

Key	Description	T-300	T-350	T-400	T-450	T-600	QTY
1	Valve, Drain (includes #2 thru #11)	9732-273-001	9732-273-001	9379-187-004	9379-187-004	9379-187-004	1
2	Body, Valve (w/ball)	9064-068-001	9064-068-001	9064-070-001	9064-070-001	9064-070-001	1
3	Motor & Gear Train (complete)	9914-137-012	9914-137-012	9914-137-011	9914-137-011	9914-137-011	1
4	Plate, Motor Mtg	9452-538-001	9452-538-001	9452-538-001	9452-538-001	9452-538-001	1
5	Screw	8639-994-001	8639-994-001	8639-994-001	8639-994-001	8639-994-001	3
6	Spring, Drive	9534-340-001	9534-340-001	9534-339-001	9534-339-001	9534-339-001	1
7	Screw	9545-054-001	9545-054-001	9545-054-001	9545-054-001	9545-054-001	2
8	Screw	9545-054-002	9545-054-002	9545-054-002	9545-054-002	9545-054-002	1
9	Seal, V Packer	9532-134-001	9532-134-001	9532-134-001	9532-134-001	9532-134-001	2
10	Washer	8641-584-001	8641-584-001	8641-584-001	8641-584-001	8641-584-001	1
11	Pin, Main Drive	9451-196-001	9451-196-001	9451-196-001	9451-196-001	9451-196-001	1
12	Plate (spacers needed for replacement motor mtg. plate)	9538-149-001	9538-149-001	9538-149-001	9538-149-001	9538-149-001	4
13	Stator and Coil Assembly	9089-036-004	9089-036-004	9089-036-004	9089-036-004	9089-036-004	1
*	Valve Drain before Serial # 482181	9379-177-006	9379-177-006	9379-187-001	9379-187-001	9379-187-001	1
*	Motor Gear Train to Fit before Serial # 482181	9914-137-012	9914-137-012	9914-137-011	9914-137-011	9914-137-011	1

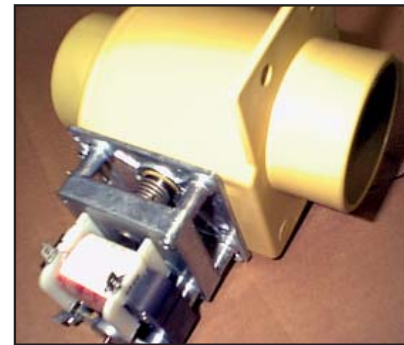
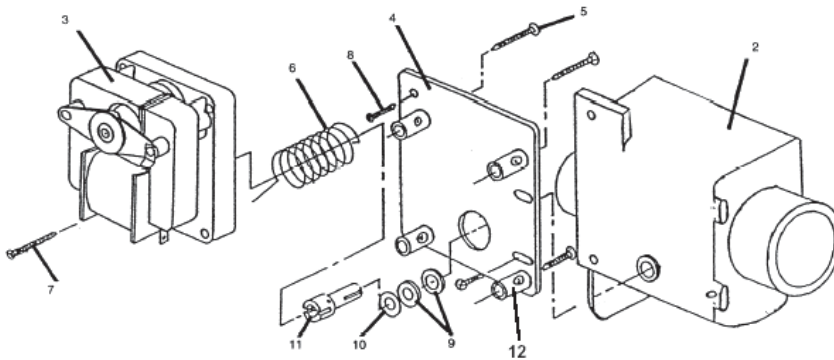

## 18lb Drain Valve Replacement Kit

#9732-273-001 Breakdown

#9732-273-001

18lb Drain Valve Replacement Kit	T-300
Drain Valve, 2" ball	9379-177-009
Hose	9242-468-001
Clamp	9242-117-009





## Chassis and Drain Part # by Model

Key	Description	T-300	T-350	T-400	T-450	T-600	QTY
1	Base Assy,Frame	9945-093-002	9945-119-002	9945-087-002	9945-116-002	9945-097-002	1
2	Outer Tub Assy	9930-135-001	9930-143-001	9930-142-001	9930-142-001	9930-146-001	1
*	Tub & Cylinder Assy	9869-006-001	9869-013-002	9869-021-001	9869-014-001	9869-017-001	1
*	Ring Assy, Tub Mtg-Front	9950-045-002	9950-046-002	9950-051-004	9950-051-004	9950-051-004	1
7	Ring Assy.Clamp Tub Mtg.- Rear	9950-046-002	9950-058-002	9950-041-004	9950-056-002	9950-056-003	1
8	Bolt, 1/2" x 1 1/4 Rings to Base	9545-017-009					4
*	Washer	8641-581-018	8641-581-018	8641-581-018	8641-581-018	8641-581-018	1
25	Hose, Tub to Drain Valve	9242-468-001	9242-468-001	9242-456-001	9242-456-001	9242-456-001	1
26	Clamp, Hose (Tub to Drain Valve)	8654-117-014	8654-117-014	8654-117-014	8654-117-014	8654-117-014	2
9	Valve, Drain	9379-177-010	9379-177-010	9379-187-004	9379-187-004	9379-187-004	1
19	Hose, Drain Valve to Tube	9242-451-002	9242-451-002	9242-457-001	9242-457-001	9242-457-001	1
19A	Clamp, Hose (Drain Valve to Tube)	8654-117-014	8654-117-014	8654-117-014	8654-117-014	8654-117-014	2
10	Bracket, Drain Valve	9029-005-001	9029-005-001	9029-056-001			1
*	Screw, Valve to Bracket 12ABx1/2	9545-008-026	9545-008-026	9545-008-026	9545-008-026	9545-008-026	2
11	Tube Assy, Drain	9915-116-004	9915-125-002	9915-119-002	9915-119-002	9915-118-002	1
*	Screw Tube (Bracket to Base 1/4Bx3/4	9545-030-002	9545-030-002	9545-030-002	9545-030-002	9545-030-002	2
12	Hose, Overflow to drain	9942-449-002	9942-449-002	9942-449-002	9942-449-002	9942-449-002	1
8	Lockwasher				8641-582-018	8641-582-018	4
8	Nut, Hex 5/8-11			8640-425-001	8640-425-001	8640-425-001	4
*	Shim, Support Assembly (thin)	9552-038-003	9552-038-003	9552-038-003	9552-038-001	9552-038-001	AR
18	Fill Hose, Vacuum Brkr. to Tub	9242-458-002	9242-458-002	9242-458-002	9242-458-002	9242-458-002	1
13	Dispenser Soap	9122-005-004	9122-005-004	9122-005-004	9122-005-004	9122-005-004	1
15	Gasket, Dispenser	9206-416-001	9206-416-001	9206-416-001	9206-416-001	9206-416-001	1
*	Nut Spring SS	8640-399-007	8640-399-007	8640-399-007	8640-399-007	8640-399-007	4
*	Hose, Dispenser to Tub	9242-450-002	9242-450-002	9242-450-002	9242-450-002	9242-450-001	1
*	Clamp, Dispenser Hose	8654-117-008	8654-117-008	8654-117-008	8654-117-008	8654-117-008	2
14	Back Ass'y, Tub	9732-137-001		9732-137-002	9732-137-003	9732-137-003	1
16	Bolt, 7/16" x 2" Tub Back to Tub	9545-029-003	9545-029-003	9545-029-003			12
17	Nut, Flange Lock	8640-415-004	8640-415-004	8640-416-005	8640-416-005	8640-416-005	12
	Hose, Pressure Switch	9242-175-000	9242-175-000	9242-175-007	9242-175-007	9242-175-001	1
	Clamp, Pressure Switch Hose	8654-117-015	8654-117-015	8654-117-015	8654-117-015	8654-117-015	1



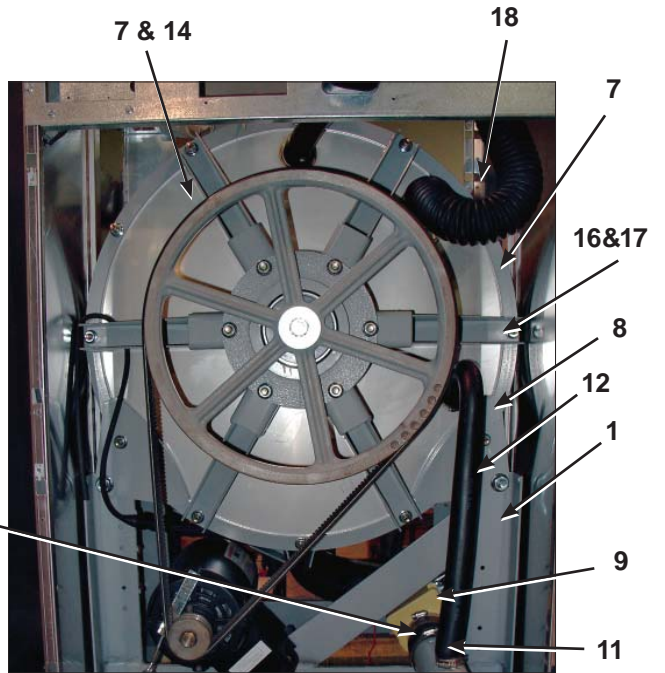
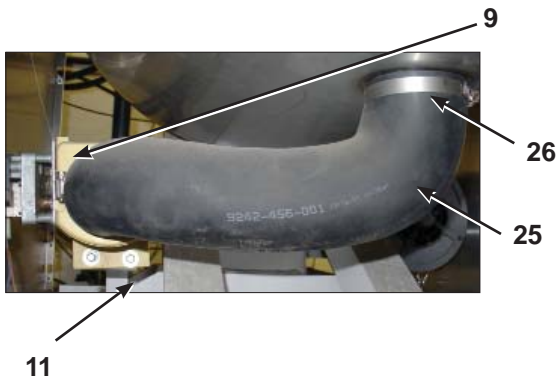
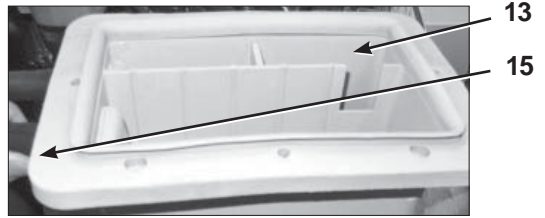
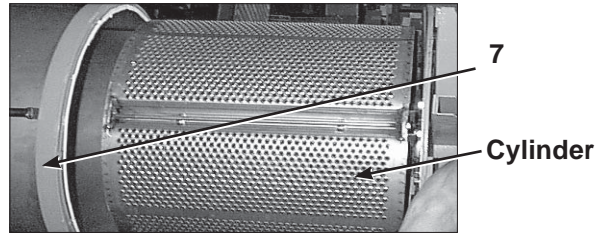
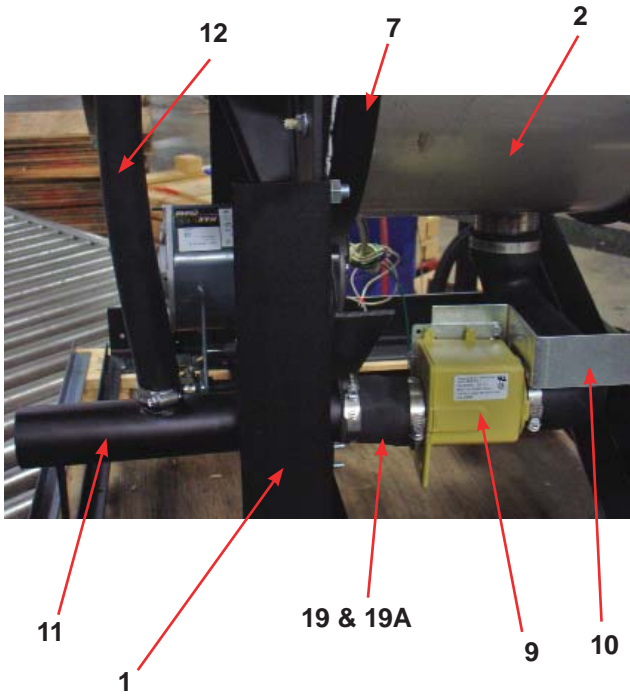

## Electrical Components - Top Compartment

Key	Description	T-300	T-350	T-400	T-450	T-600	QTY
1	Trough Assy,Controls 120 Volt (all parts below #2-#43 & trough)	9857-149-001					1
1	Trough Assy,Controls 208-240 volt (all parts below #2-#43 & trough)	9857-150-001	9857-157-003	9857-151-001	9857-151-003	9857-152-001	1
*	Trough only	9839-015-001	9839-015-001	9839-015-001	9839-015-001	9839-015-001	1
*	Screw, Trough Sides	9545-008-026	9545-008-026	9545-008-026	9545-008-026	9545-008-026	4
*	Lockwasher Exttooth #10	8641-582-006	8641-582-006	8641-582-006	8641-582-006	8641-582-006	4
5	Angle Support Trough	9003-270-001	9003-295-001	9003-270-001	9003-298-001	9003-271-001	1
6	Screw, Trough Bracket	9545-008-026	9545-008-026	9545-008-026	9545-008-026	9545-008-026	3
7	Transformer, Control (Secondary Voltage to 115 volts)	8711-004-001	8711-004-001	8711-004-001	8711-004-001	8711-004-001	1
*	Screw, Mtg #8Bx1/4"	9545-008-026	9545-008-026	9545-008-026	9545-008-026	9545-008-026	4
*	Lockwasher	8641-582-006	8641-582-006	8641-582-006	8641-582-006	8641-582-006	4
*	Screw GRN. #10-32x 1/2"	8639-621-007	8639-621-007	8639-621-007	8639-621-007	8639-621-007	1
*	Lockwasher #10	8641-582-006	8641-582-006	8641-582-006	8641-582-006	8641-582-006	1
*	Lug, Grounding	8652-130-037	8652-130-037	8652-130-037	8652-130-037	8652-130-037	1
12	Hose, Overflow Top Vent Rear	9942-449-002	9942-449-002	9942-449-002	9942-449-002	9942-449-002	1
15	PCB assembly Relay Main	9473-006-001	9473-006-001	9473-006-001	9473-006-001	9473-006-001	1
18	Harness Drain/Therm/Sol	9627-796-001	9627-796-001	9627-796-001	9627-796-001	9627-796-002	1
19	Harness P19/Water Valve	9627-795-003	9627-795-003	9627-795-003	9627-795-003	9627-795-004	1
20	Harness P8/P16	9627-794-001	9627-794-001	9627-794-001	9627-794-001	9627-794-001	1
21	Harness P20/P21	9627-793-001	9627-793-001	9627-793-001	9627-793-001	9627-793-001	1
*	Bushing , Wire 7/8	9053-067-002	9053-067-002	9053-067-002	9053-067-002	9053-067-002	2
*	Standoff Twistlock	9527-002-002	9527-002-002	9527-002-002	9527-002-002	9527-002-002	3
*	Standoff Twistlock	9527-002-003	9527-002-003	9527-002-003	9527-002-003	9527-002-003	2
26	Dynamic Braking Resistor	9483-004-002	9483-004-002	9483-004-002	9483-004-002	9483-004-002	2
27	Screws #10-32x1/2" (pnhdcr)	9545-012-008	9545-012-008	9545-012-008	9545-012-008	9545-012-008	4
28	Nuts, #10-32 UNF 2B	8640-413-002	8640-413-002	8640-413-002	8640-413-002	8640-413-002	4
30	Screw #6-32x5/16"	9545-044-006	9545-044-006	9545-044-006	9545-044-006	9545-044-006	4
31	Nuts Hex #6-32	8640-411-003	8640-411-003	8640-411-003	8640-411-003	8640-411-003	4
32	Terminal Block Assy, POWER	9897-034-001	9897-034-001	9897-034-001	9897-034-001	9897-034-001	1
*	Screw, Mtg 8Bx3/8"	9545-045-007	9545-045-007	9545-045-007	9545-045-007	9545-045-007	2
*	Strip, Terminal Marker	9558-027-001	9558-027-001	9558-027-001	9558-027-001	9558-027-001	1
35	Switch, Pressure	9539-457-002	9539-491-001	9539-457-003	9539-491-001	9539-457-003	1
36	Screw, Mtg #8Bx1/4"	9545-045-001	9545-008-026	9545-045-001	9545-045-001	9545-045-001	2
37	Harness P5/Pressure	9627-800-001	9627-801-001	9627-801-001	9627-801-001	9627-802-001	1
38	Transformer, (Step Down) 120/2.3 VAC&24 VAC 50/60hz	8711-009-001	8711-009-001	8711-009-001	8711-009-001	8711-009-001	1
39	Screw, Transformer Mtg #10Bx1/2"	9545-045-001	9545-045-001	9545-045-001	9545-045-001	9545-045-001	2
40	Lockwasher #10 exttooth	8641-582-005	8641-582-005	8641-582-005	8641-582-005	8641-582-005	2
48	Label Fuse 1.5 amp Rear	8502-716-001	8502-716-001	8502-716-001	8502-716-001	8502-716-001	1
49	Cover Electrical (Rear Main Terminal Block)	9074-267-001	9074-267-001	9074-267-001	9074-267-001	9074-267-001	1

# Electrical Components - Top Compartment

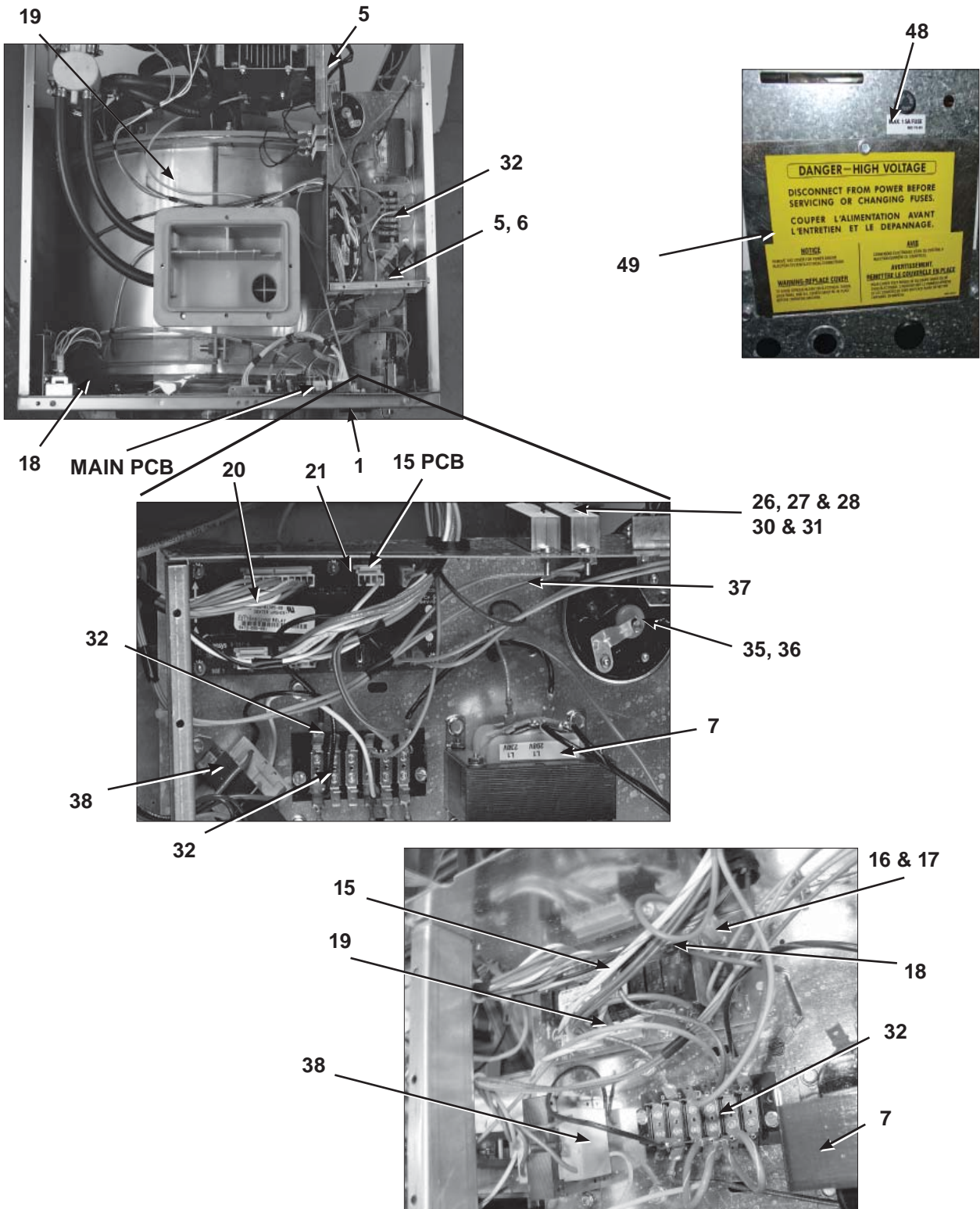

Key	Description	T-300	T-350	T-400	T-450	T-600	QTY
*	Screw 8B x 1/2	9545-045-002	9545-045-002	9545-031-010			2
*	Wiring Harness Power Terminal to VFD	9627-831-001	9627-831-001	9627-747-003	9627-747-003	9627-747-003	1
*	Plastic Shield Over Water Valve	9550-186-001	9550-186-001	9550-186-001	9550-186-001	9550-186-001	1

## Control Panel Part # by Model

Key	Description	T-300	T-350	T-400	T-450	T-600	QTY
1	Panel Control Assembly(panel only)	9989-522-001	9989-522-001	9989-523-001	9989-523-001	9989-524-001	1
*	Screw, Hxwshrdundct #10Bx 1/2"	9545-008-026	9545-008-026	9545-008-026	9545-008-026	9545-008-026	4
2	Post Locator Top	9467-024-001	9467-024-001	9467-024-001	9467-024-001	9467-024-001	2
*	Nut Hexkeps #6-32	8640-411-003	8640-411-003	8640-411-003	8640-411-003	8640-411-003	2
3	Locator Panel	9355-001-001	9355-001-001	9355-001-001	9355-001-001	9355-001-001	2
*	Screw FillHDCR 10Bx1/2" Guide	9545-008-023	9545-008-023	9545-008-023	9545-008-023	9545-008-023	2
*	Spacer Pushbutton (Micro)	9538-178-001	9538-178-001	9538-178-001	9538-178-001	9538-178-001	1
*	Retainer Pushbutton (Micro)	9486-150-001	9486-150-001	9486-150-001	9486-150-001	9486-150-001	1
*	Nut Hexelasticstop #4-40	8640-424-002	8640-424-002	8640-424-002	8640-424-002	8640-424-002	2
10	Pushbutton Control (coin)	9035-060-003	9035-060-003	9035-060-003	9035-060-003	9035-060-003	1
7	PCB assembly Control /Display STOP	9473-009-002	9473-009-002	9473-009-002	9473-009-002	9473-009-002	1
11	Spacer Plastic #6x9/16	9538-157-018	9538-157-018	9538-157-018	9538-157-018	9538-157-018	5
11	Nut Elasticstop #6-32	8640-411-002	8640-411-002	8640-411-002	8640-411-002	8640-411-002	5
12	Harness LEDPCB	9627-797-001	9627-797-001	9627-797-001	9627-797-001	9627-797-001	1
8	Harness Doorlock, Switches	9627-791-003	9627-791-003	9627-791-003	9627-791-003	9627-791-004	1
16	PCB assembly Mode lights	9473-005-001	9473-005-001	9473-005-001	9473-005-001	9473-005-001	1
*	Spacer Plastic #6x9/16	9538-157-018	9538-157-018	9538-157-018	9538-157-018	9538-157-018	2
*	Nut Hexkeps #6-32	8640-411-003	8640-411-003	8640-411-003	8640-411-003	8640-411-003	2
19	Light, LED,ADD BLEACH Assembly	9794-001-001	9794-001-001	9794-001-001	9794-001-001	9794-001-001	1
*	Spacer Plastic #6x9/16	9538-157-018	9538-157-018	9538-157-018	9538-157-018	9538-157-018	2
*	Nut Hexeps #6-32	8640-411-003	8640-411-003	8640-411-003	8640-411-003	8640-411-003	2
9	Nameplate,Control Panel (Blue)	9412-135-001	9412-156-001	9412-137-001	9412-159-001	9412-139-001	1
9	Nameplate,Control Panel (Black)	9412-168-001	9412-169-001	9412-170-001	9412-166-001	9412-171-001	1
9	Label Name Plate RH (Blue)	8502-726-001	8502-726-001	N.A.	N.A.	N.A.	1
	Label Name Plate RH (Black)	8502-744-001	8502-744-001	N.A.	N.A.	N.A.	1
22	Switch Assembly Emergency Stop (includes wire harness)	9732-223-001	9732-223-001	9732-223-001	9732-223-001	9732-223-001	1
*	Spacer Plastic #8x5/16 E-Stop	9538-157-020	9538-157-020	9538-157-020	9538-157-020	9538-157-020	2
*	Nut HexKep #8-32 E-Stop	8640-412-005	8640-412-005	8640-412-005	8640-412-005	8640-412-005	2
*	Solenoid Ass'y, Door Locking (see Door Lock Group for parts breakdown)	9922-011-001	9922-011-001	9922-011-001	9892-014-001	9922-011-001	1
*	Hex Nuts (mounting solenoid assy. to control panel)	8640-412-005	8640-412-005	8640-412-005	8640-412-005	8640-412-005	3

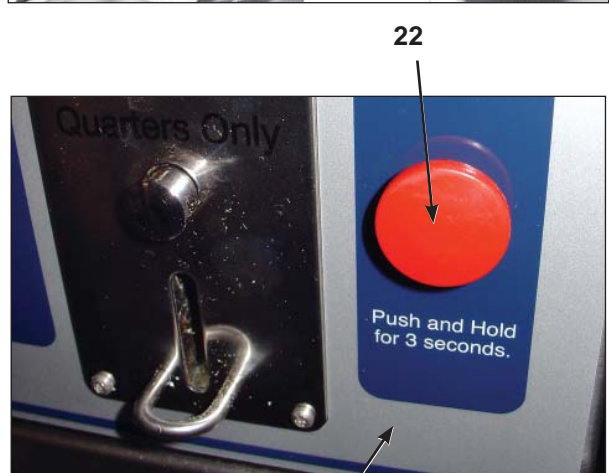
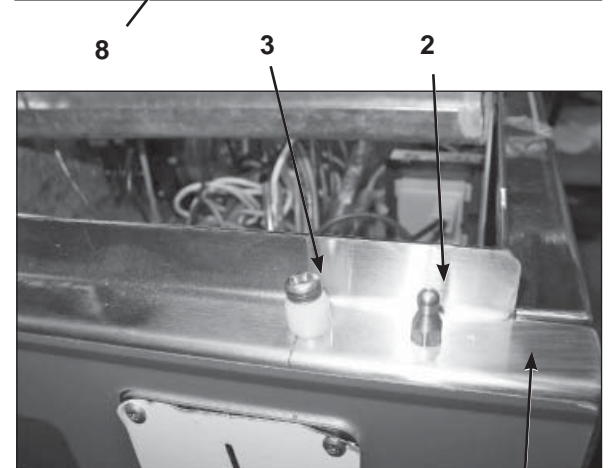
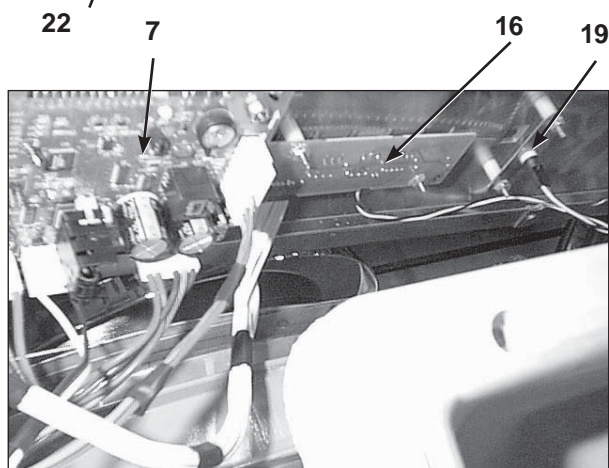
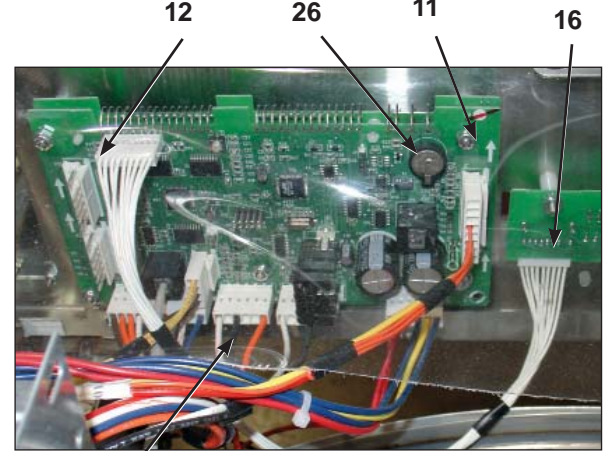
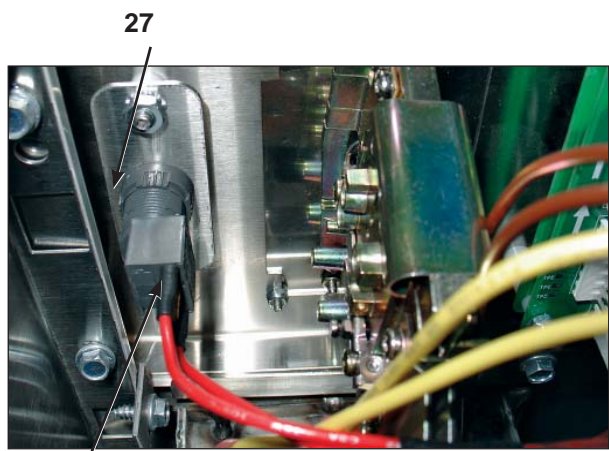

## Labels and Diagrams All WCAD Models

Key	Description	T-300	T-350	T-400	T-450	T-600	QTY
*	Wiring Diagram, Coin, Micro Switch (120 V)	9506-117-001 Rev A					1
*	Wiring Diagram, Coin, Optical (120 V)	9506-117-001 Rev C					1
*	Wiring Diagram, Coin, Electronic Acceptor (120 V)	9506-131-001					1
*	Wiring Diagram Easy Card (120 V)	9506-103-001					1
*	Wiring Diagram, CN, No Acceptor (120 V)	9506-390-001					1
*	Wiring Diagram, Coin Micro Switch	9506-119-001 Rev A	9506-239-001 Rev A	9506-121-001 Rev A	9506-121-001 Rev A	9506-125-001 Rev A	1
*	Wiring Diagram, Coin, Optical	9506-119-001 Rev C	9506-239-001 Rev C	9506-121-001 Rev C	9506-121-001 Rev C	9506-125-001 Rev A	1
*	Wiring Diagram, Coin, Electronic Acceptor	9506-133-001	9506-245-001	9506-135-001	9506-135-001	9506-139-001	1
*	Wiring Diagram (Easy Card)	9506-105-001	9506-241-001	9506-107-001	9506-107-001	9506-111-001	1
*	Wiring Diagram, CN, No Acceptor	9506-392-001	9506-321-001	9506-394-001	9506-394-001	9506-398-001	
*	Instructions Spin Direction	8507-273-001	8507-273-001	8507-274-001	8507-274-001	8507-274-001	1
*	Wiring Schematic, Coin Micro Switch (120 V)	9506-116-001 Rev A					1
*	Wiring Schematic, Coin, Optical (120 V)	9506-116-001 Rev C					1
*	Wiring Schematic, Coin, Electronic Acceptor (120 V)	9506-130-001					1
*	Wiring Schematic, Easy Card (120 V)	9506-102-001					1
*	Wiring Schematic, CN, (120V) No Acceptor	9506-389-001					1
*	Wiring Schematic, Coin Micro Switch	9506-118-001 Rev A	9506-238-001 Rev A	9506-120-001 Rev A	9506-120-001 Rev A	9506-124-001 Rev A	1
*	Wiring Schematic, Coin, Optical	9506-118-001 Rev C	9506-238-001 Rev C	9506-120-001 Rev C	9506-120-001 Rev C	9506-124-001 Rev A	1
*	Wiring Schematic, Coin, Electronic Acceptor	9506-132-001	9506-244-001	9506-134-001	9506-134-001	9506-138-001	1
*	Wiring Schematic, Easy Card	9506-104-001	9506-240-001	9506-106-001	9506-106-001	9506-110-001	1
*	Wiring Schematic, CN, No Acceptor	9506-391-001	9506-320-001	9506-393-001	9506-393-001	9506-397-001	1
*	Transient Voltage Surge Suppressor Infomational	8507-330-001	8507-330-001	8507-330-001	8507-330-001	8507-330-001	1
*	Label High Voltage Warning	8502-614-004	8502-614-004	8502-614-004	8502-614-004	8502-614-004	1
*	Label Fusing & Installation	8502-619-004	8502-619-004	8502-619-004	8502-619-004	8502-619-004	1
*	Label Quality	8511-001-002	8511-001-002	8511-001-002	8511-001-002	8511-001-002	1
*	Booklet Owners	8514-167-001	8514-169-001	8514-175-001	8514-177-001	8514-097-001	1
							1

---

# Section 9:

Coin Handling

Parts:

Wiring Diagrams

& Schematics &

maintenance Procedures

# Coin Handling Group Part # Micro Switch

Key	Description	T-300	T-350	T-400	T-450	T-600	QTY
1	Vault, Assy Grey	9942-033-001	9942-033-001	9942-033-002	9942-033-002	9942-033-003	1
1	Vault, Assy. Black	9942-033-008	9942-033-008	9942-033-009	9942-033-009	9942-033-010	
*	Screw, 10Bx 1/2" Vault Mtg	9545-008-026	9545-008-026	9545-008-026	9545-008-026	9545-008-026	2
2	Coin Chute Assy.	9119-031-001	9119-031-001	9119-031-001	9119-031-001	9119-031-001	1
*	Screw, Chute Mtg	9545-008-001	9545-008-001	9545-008-001	9545-008-001	9545-008-001	1
3	Coin Acceptor chute without penny rejector for mechanical drop (standard)	9119-025-002	9119-025-002	9119-025-002	9119-025-002	9119-025-002	1
*	Screw, Acceptor Mtg	9545-020-004	9545-020-004	9545-020-004	9545-020-004	9545-020-004	4
*	Nut	8640-424-002	8640-424-002	8640-424-002	8640-424-002	8640-424-002	4
4	Switch, Coin (fits single coin mechanical drop)	9732-126-001	9732-126-001	9732-126-001	9732-126-001	9732-126-001	1
5	Coin Acceptor chute with penny rejector for mechanical drop (optional)	9119-025-001	9119-025-001	9119-025-001	9119-025-001	9119-025-001	
6	Button Coin Return Retainer	9486-133-001	9486-133-001	9486-133-001	9486-133-001	9486-133-001	1
7	Coin Acceptor Mechanical Complete	9021-001-010	9021-001-010	9021-001-010	9021-001-010	9021-001-010	1
8	Soloid, Coin Blocking (V-Series)						1
*	Screw, Highth Bar, 3mm	9545-039-002	9545-039-002	9545-039-002	9545-039-002	9545-039-002	2
*	Harness, Coin Switch V & A Series	9627-792-001	9627-792-001	9627-792-001	9627-792-001	9627-792-001	1

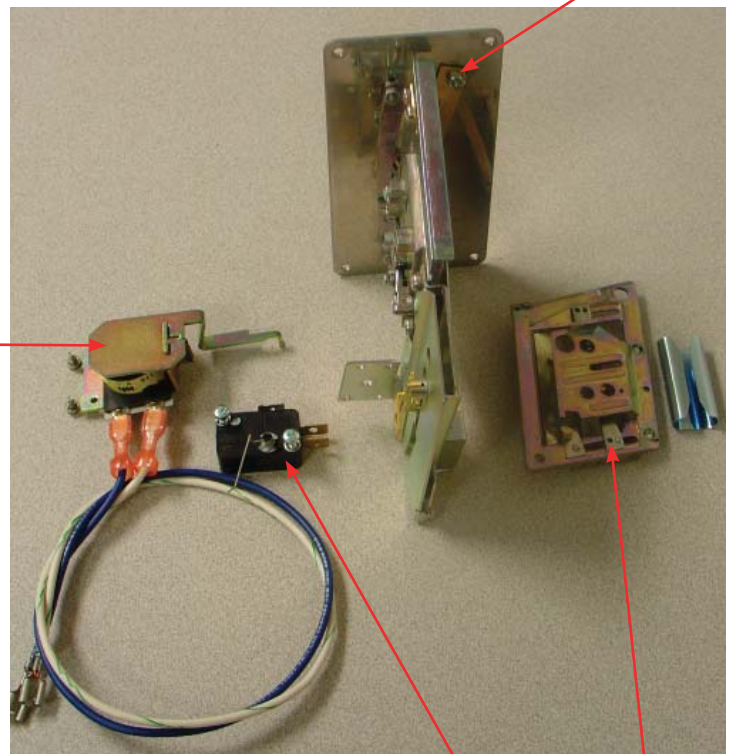
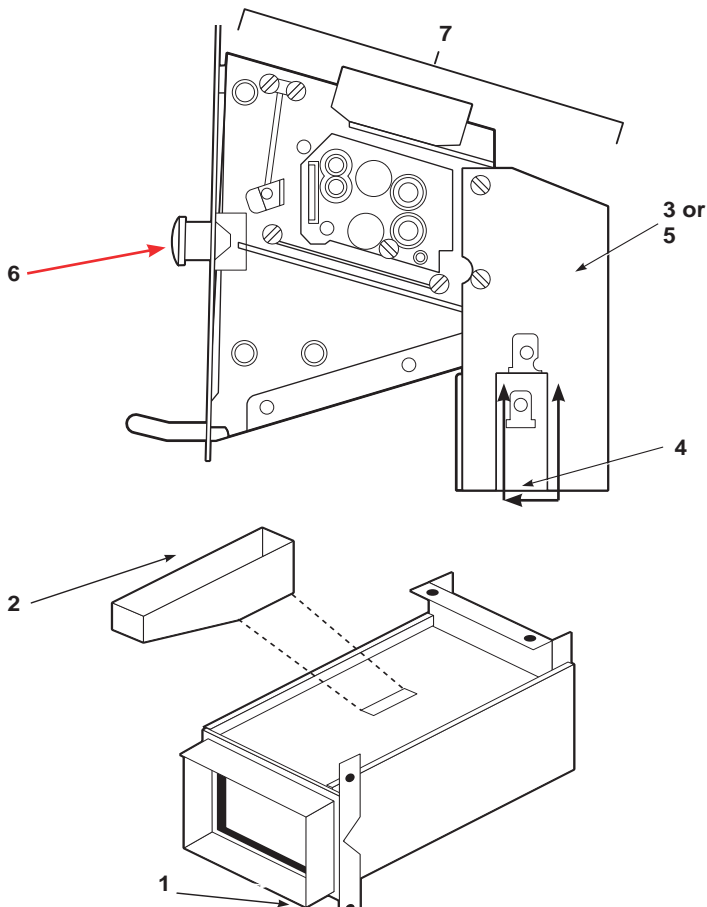



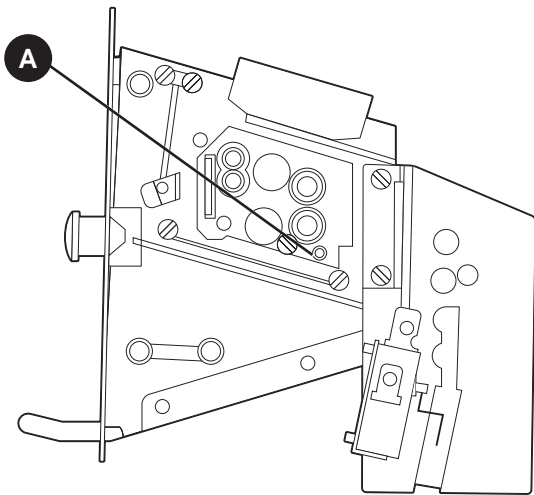

Left View Coin Drop Acceptor

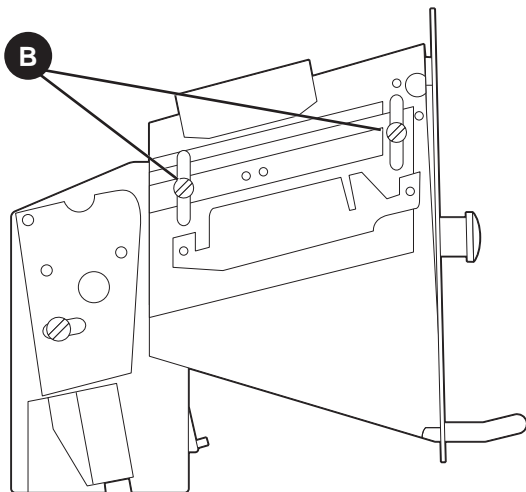

Right View Coin Drop Acceptor

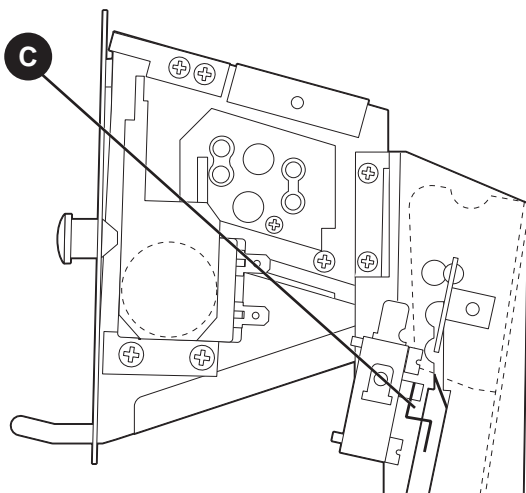

## Mechanical Acceptor

### Standard Coin Drop Acceptor

The drop style coin acceptor contains a coin switch that is actuated by each good coin that is accepted.

### Removal

The coin acceptor is removed by loosening the two Torx T-10 machine screws on the right side and by removing completely the two Torx T-10 machine screws on the left side (#T-10 Torx driver, Dexter Pt. No. 8545-051-003). There are locking nuts on the back side that will have to be held. Needle-nose pliers work well for this. Sliding the acceptor to the left will remove it from the slots in the front panel. This gives access to the coin switch and acceptor for adjustments.

### Coin Thickness Adjustment (see diagram)

On the right side of the acceptor there is a coin thickness adjusting screw "A" with a locking nut. To allow for different thickness coins the screw can be turned in to accept thicker coins and turned out to reject thicker coins. Start with a quarter of a turn on this screw and be sure to retighten the lock nut after adjustment.

### Coin Height Adjustment (see diagram)

On the left side of the acceptor is a coin height adjusting bar "B". This bar is adjusted by loosening the two mounting screws and moving both ends of the bar up or down equal amounts. The bar should be raised as high as possible while still accepting the correct coins. If it is raised up too high, the good coins will be rejected.

### Coin Switch Adjustment (see diagram)

The normally open coin switch "C" should click (close) soon after the coin hits the operator wire. However, there must be enough travel to allow the switch to reset (open) once the coin has passed. Adjustment should be made by bending the wire very close to its attachment point.

# Optical Coin Acceptor

Starting after serial# 515483

Key-	Description	T-300	T-350	T-400	T-450	T-600	
1	Optical Coin Acceptor	9021-016-001	9021-016-001	9021-016-001	9021-016-001	9021-016-001	1
2	Replacement Optical Sensor	9801-099-001	9801-099-001	9801-099-001	9801-099-001	9801-099-001	1
*	Screw, Highth Bar, 3mm	9545-039-002	9545-039-002	9545-039-002	9545-039-002	9545-039-002	2

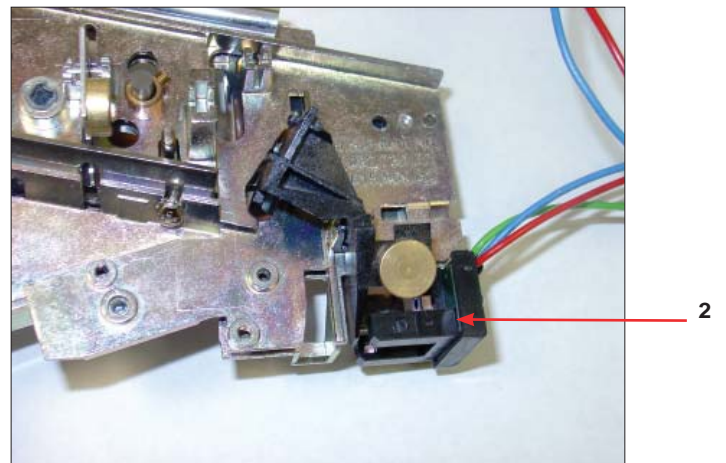
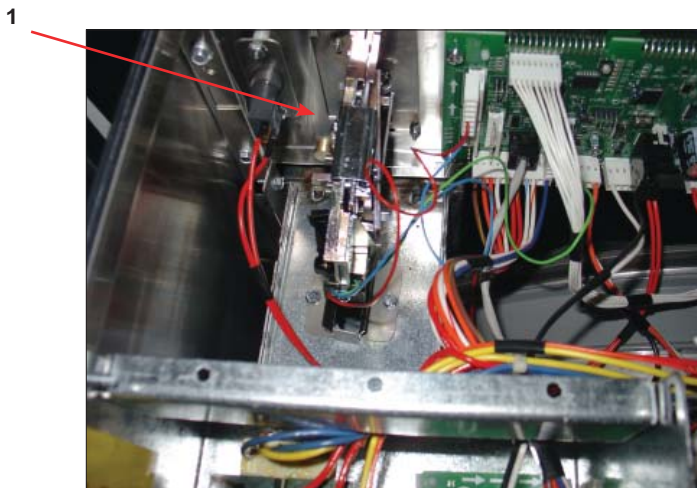
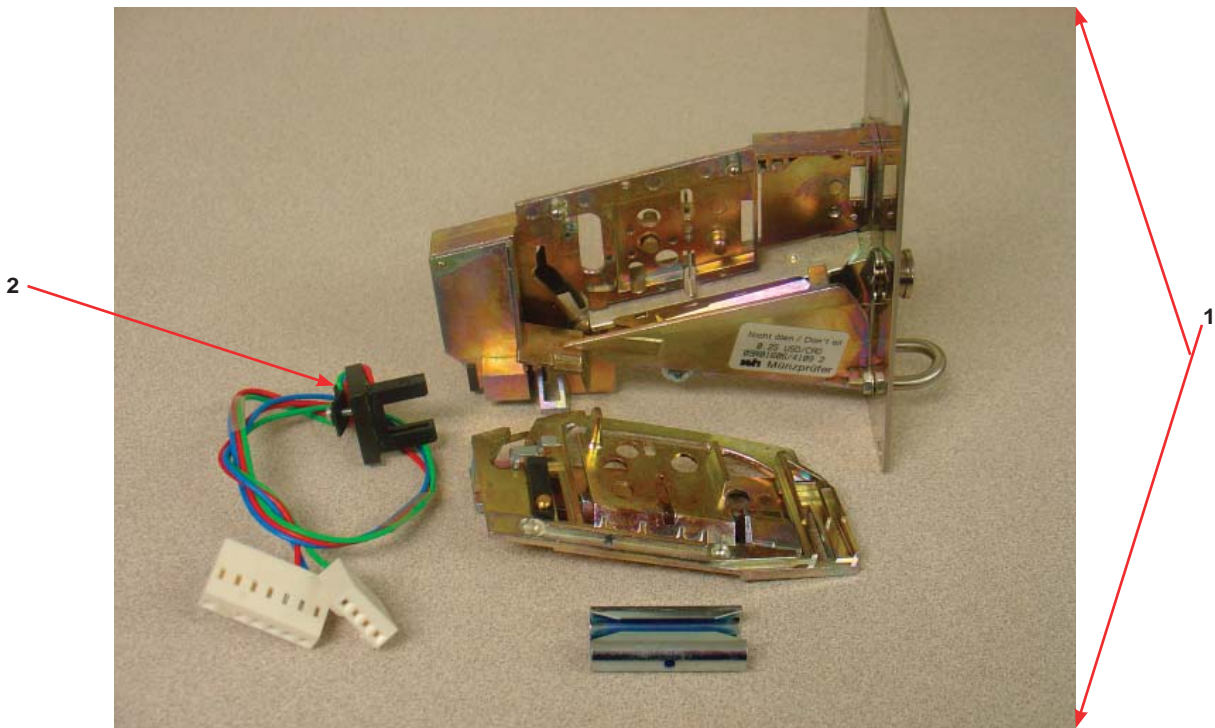

# Kit - Electronic Acceptor Conversion for WCAD (USA and Canada)

Key	Description	T-300	T-350	T-400	T-450	T-600	QTY
	KIT - Electronic Acceptor Conversion for WCAD (USA and Canada) Contact the Dexter Factory for Other Countries	9732-282-007	9732-282-007	9732-282-007	9732-282-007	9732-282-007	1
1	Electronic Coin Acceptor (USA and Canada)	9021-028-001	9021-028-001	9021-028-001	9021-028-001	9021-028-001	1
2	Harness for Electronic Coin Acceptor	9627-845-001	9627-845-001	9627-845-001	9627-845-001	9627-845-001	1
3	Transformer 120/18VAC	8711-015-001	8711-015-001	8711-015-001	8711-015-001	8711-015-001	1
*	Wire Assembly - Blue	8220-001-338	8220-001-338	8220-001-338	8220-001-338	8220-001-338	1
*	Wire Assembly - Orange/White	8220-001-235	8220-001-235	8220-001-235	8220-001-235	8220-001-235	1
4	Coin Chute for Electronic Drop	9119-028-001	9119-028-001	9119-028-001	9119-028-001	9119-028-001	1
*	Nut - Hex Elastic Stop	8640-424-002	8640-424-002	8640-424-002	8640-424-002	8640-424-002	1
*	Screw, Torx	9545-020-004	9545-020-004	9545-020-004	9545-020-004	9545-020-004	4
*	Screw, Hex	9545-045-001	9545-045-001	9545-045-001	9545-045-001	9545-045-001	4
*	Label, Informative	6102-017-001	6102-017-001	6102-017-001	6102-017-001	6102-017-001	2
*	Label, Warning	8502-730-001	8502-730-001	8502-730-001	8502-730-001	8502-730-001	1
*	Instructions, Installation	8507-367-001	8507-367-001	8507-367-001	8507-367-001	8507-367-001	1
5	Catch Spring (for Clean Out Door)	9534-367-001	9534-367-001	9534-367-001	9534-367-001	9534-367-001	1

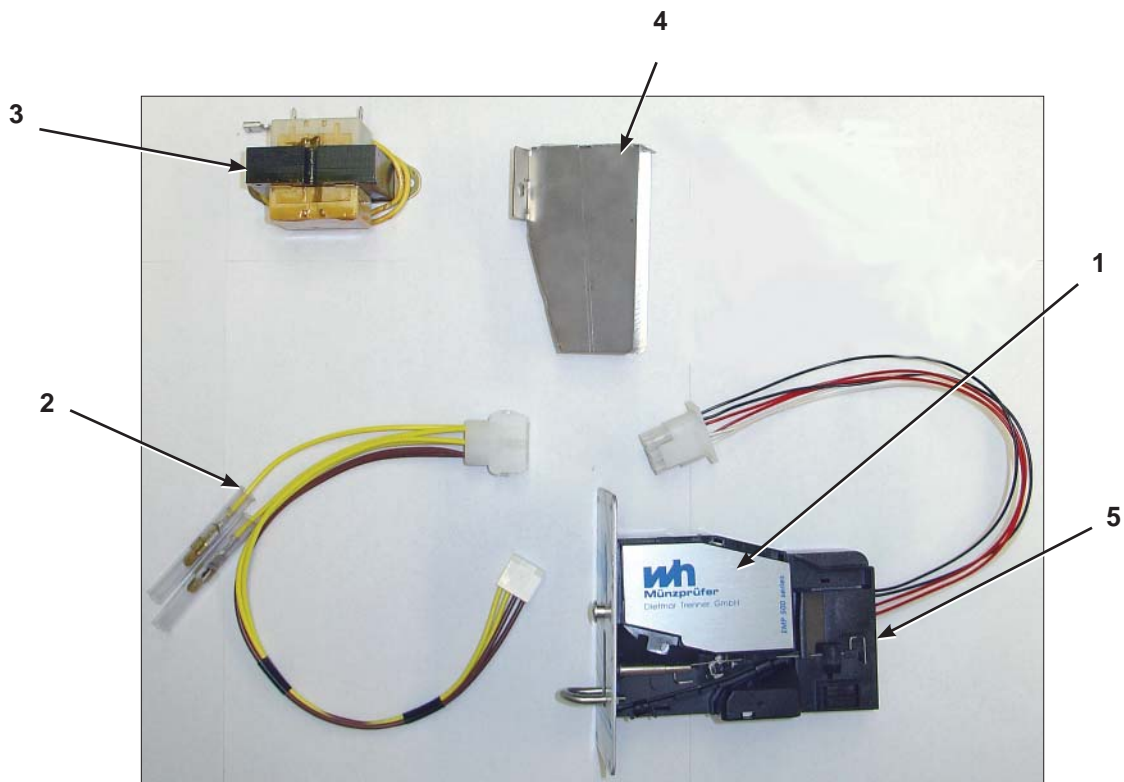

# Electronic Acceptor Coin Drop

## Setting the electronic coin acceptor switches

Some washer models come equipped with an electronic coin acceptor. Follow the instructions below for setting the switches for the desired country and currencies.

1. The electronic coin acceptor has switch settings depending on the coins and country. See the table below for available values of the left and right coin inputs for the available countries.

**WARNING:** turn power off before and leave power off when changing the switches of the electronic coin acceptor.

2. Turn power back on and test coins to ensure proper operation.

Acceptor P/N	Country	Left Coin	Right Coin	SWs 1-8	SWs 9-16	
9021-028-001	Canada	25¢		↓↑↑↑↑↑↓	↓↑↑↑↑↑↓	
	Canada		\$1	↑↑↓↓↑↑↓	↓↑↑↑↑↑↓	
	Canada		\$2	↑↑↑↑↓↓↓	↓↑↑↑↑↑↓	
				↓↑↑↑↑↑↓	↑↓↑↑↑↑↓	
				↑↑↓↓↑↓↓	↑↓↑↑↑↑↓	
				↓↑↑↑↑↑↓	↑↑↓↑↑↑↓	
				↑↑↓↓↑↓↓	↑↑↓↑↑↑↓	
				↓↑↑↑↑↑↓	↑↑↑↓↑↑↓	
		Greenwald 118-1 Token		↑↑↑↑↑↑↓	↑↑↑↓↑↑↓	
		Greenwald 118-5 Token		↑↑↑↑↑↑↓	↑↑↑↑↓↑↓	
		U.S.A.	25¢		↓↑↑↑↑↑↓	↑↑↑↑↑↓↓
		U.S.A.		\$1	↑↑↓↓↑↑↓	↑↑↑↑↑↓↓
9021-011-001	Australia	10¢		↓↑↑↑↑↑↓	↑↓↑↑↑↑↓	
	Australia	20¢		↑↑↓↓↑↑↓	↑↓↑↑↑↑↓	
	Australia		\$1	↑↑↑↑↓↑↓	↑↑↓↑↑↑↓	
	Australia		\$2	↑↑↑↑↑↓↓	↓↑↓↑↑↑↓	
	New Zealand	10¢		↓↑↑↑↑↑↓	↑↓↑↑↑↑↓	
	New Zealand	20¢		↑↑↓↓↑↑↓	↑↓↑↑↑↑↓	
	New Zealand		\$1	↑↑↑↑↓↑↓	↑↑↑↓↑↑↓	
	New Zealand		\$2	↑↑↑↑↑↓↓	↓↑↓↑↑↑↓	
	Hong Kong	\$5		↓↓↓↓↑↑↓	↑↑↑↑↓↑↓	
	Hong Kong		\$10	↑↑↑↑↓↑↓	↑↑↑↓↑↑↓	
		Greenwald 118-1 Token		↑↑↑↑↑↑↓	↑↑↑↑↓↑↓	
		Greenwald 118-5 Token		↑↑↑↑↑↑↓	↑↑↑↑↑↓↓	

**NOTE:** Coins and tokens in the left coin column will result in one pulse to the left coin input.

**NOTE:** The \$1, 500¥, 50NT, and \$10 coins in the right coin column will result in one pulse to the right coin input, while the \$2 coins will result in two pulses to the right coin input.

Note: Acceptance of multiple coins per country and multiple tokens is allowed. Only the down/off setting for each coin and token is required to accept that coin or token.

# Maintenance Instructions

## Electronic Acceptor

### 1. Instructions to open the flap of the coin selector

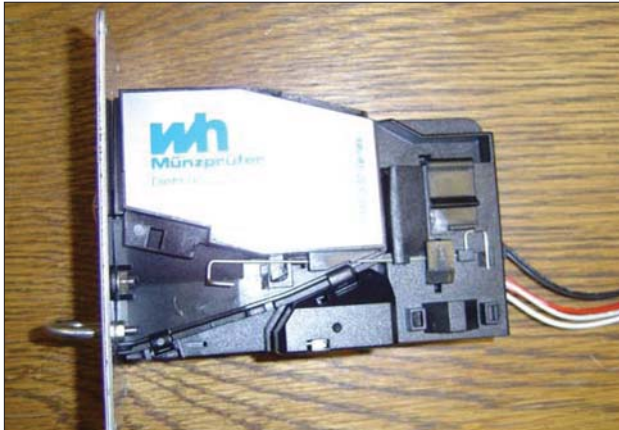

Original situation

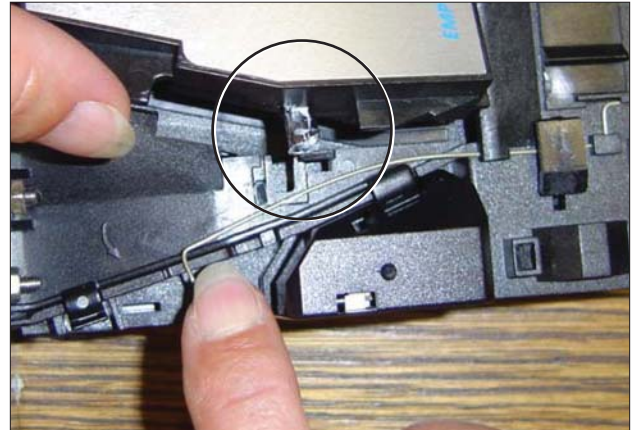

Move spring downwards to free the catch.

#### NOTE:

- Do not lift the spring
- Do not over bend the spring in any direction.

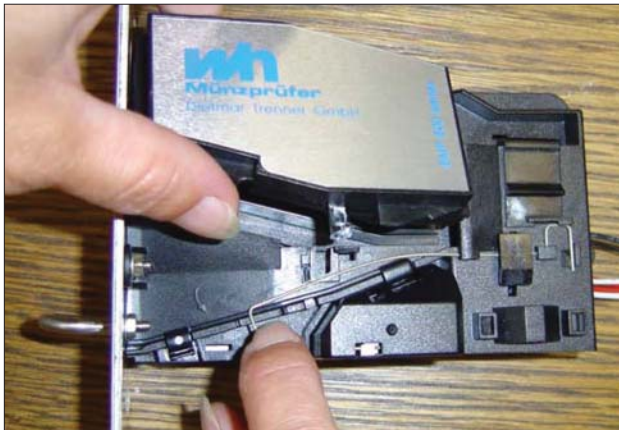

Open the flap of the coin selector.

### 2. Assembly instructions to change a spring

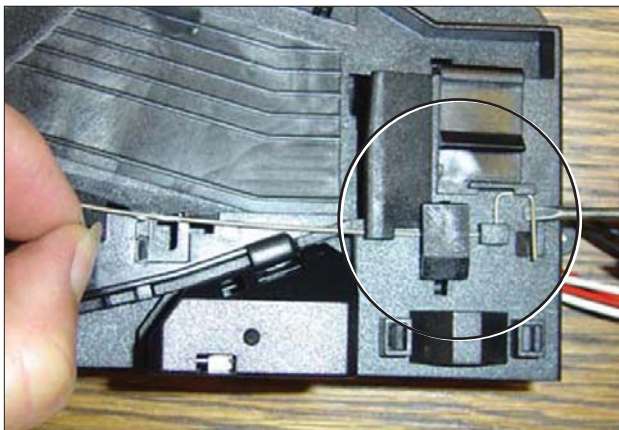

Lift the right end of the spring by means of a screw driver.

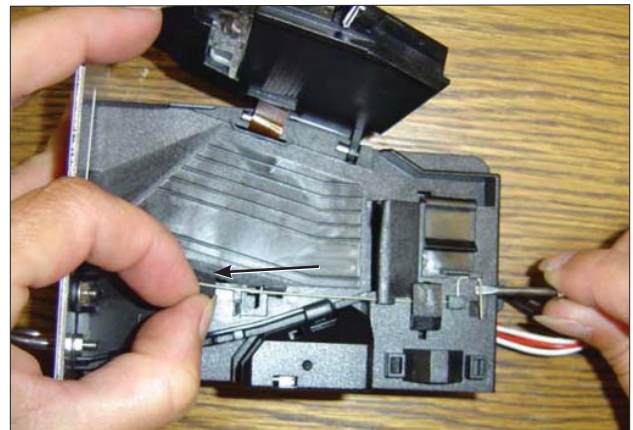

Pull the spring approximately 3 mm to the left.

# Electronic Acceptor

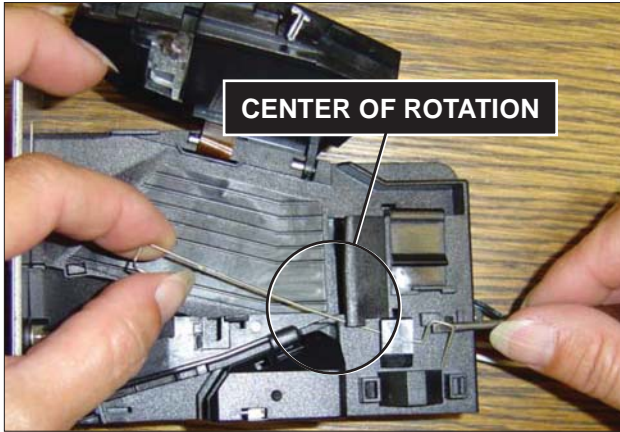

Rotate the spring clockwise for about 40 to 60 degrees until it becomes free of the protrusion.

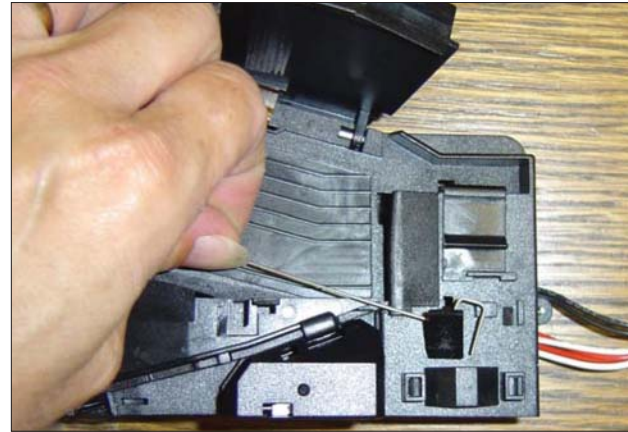

Lift off the spring with the attached plastic part.

### 3. Assembly of a new spring

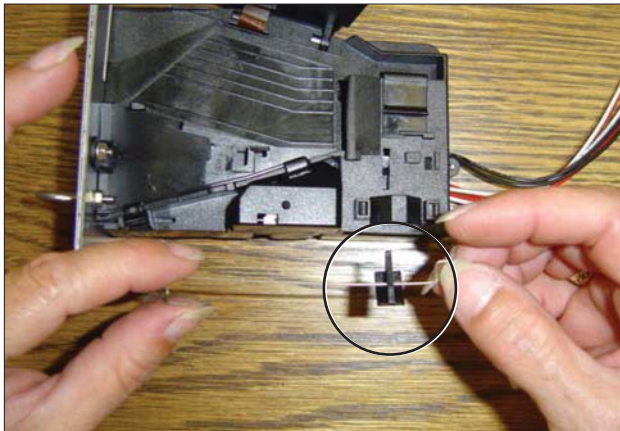

Attach the plastic part to the new spring.

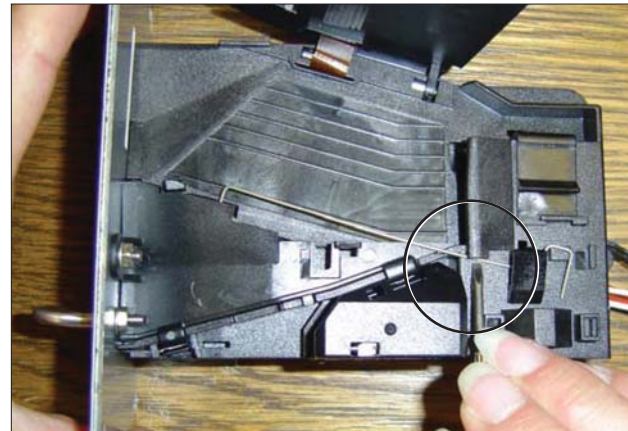

Place the plastic part in its position (slot).

Push the spring below the protrusion by means of a small screw driver.

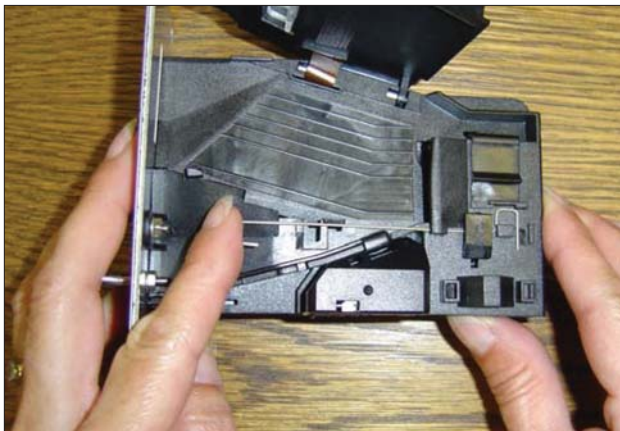

Push the spring lateral to the right until its snaps into its proper position.

# Electronic Acceptor

## 4. Close the coin selector

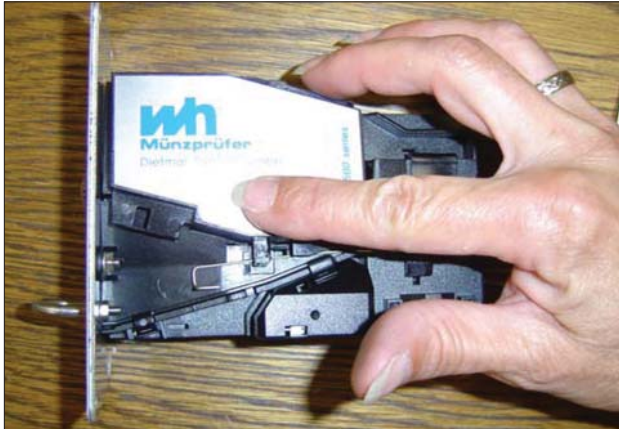

To shut the coin selector follow pictures 1 to 3 in reverse order.

## 5. Cleaning the electronic coin selector

The EMP 500 v4 is an extraordinarily robust coin selector and operates relatively maintenance free. However, it should be cleaned at regular intervals (minimum once a year) especially if it is operating in an environment with high levels of dust, smoke or nicotine. The cleaning intervals are of course dependent on the level of air borne contaminants.



Clean the coin path with a soft brush and wipe the exposed surfaces. Use an alcohol moistened cloth. If you find solid residues stuck to the coin rail (pa-



tina) remove it with an alcohol moistened cloth.

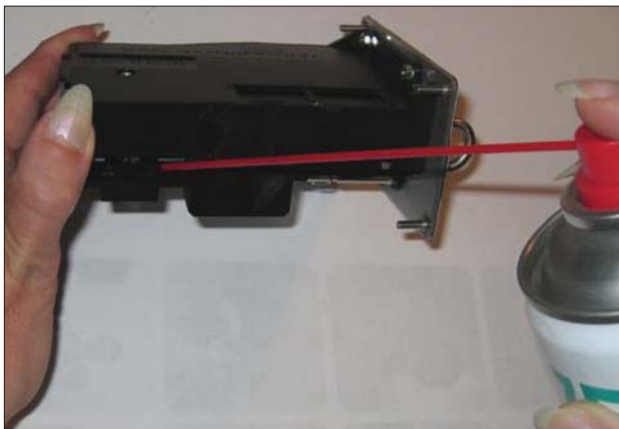

Optical sensors may be cleaned with a soft brush or very carefully with an air spray duster.

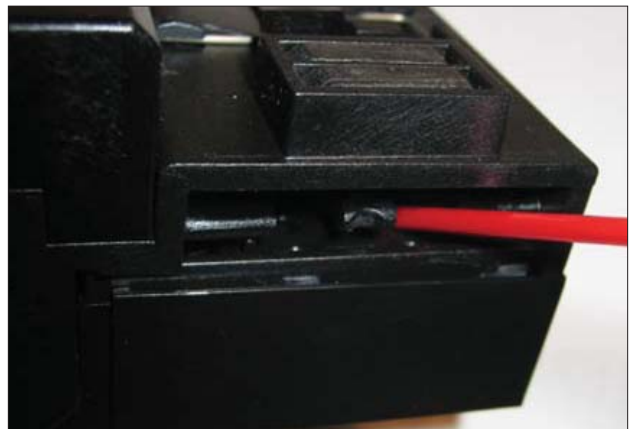

Location of the optical sensor within coin outlet.

# Electronic Acceptor

## 6. Adding the bolt #4036

A bolt can be added to the EMP 500 v4 to reduce attempts of vandalism or to protect the unit from improper use. Please note that some front plates/cashboxes might not allow mounting this additional device.



The bolt (part number 4036) should be mounted with the help of a screw driver.



Screw the bolt onto the existing stud weld on top of the nut which fixes the reject bracket.



Once the bolt is fixed, please verify the position of the spring as indicated in the picture.

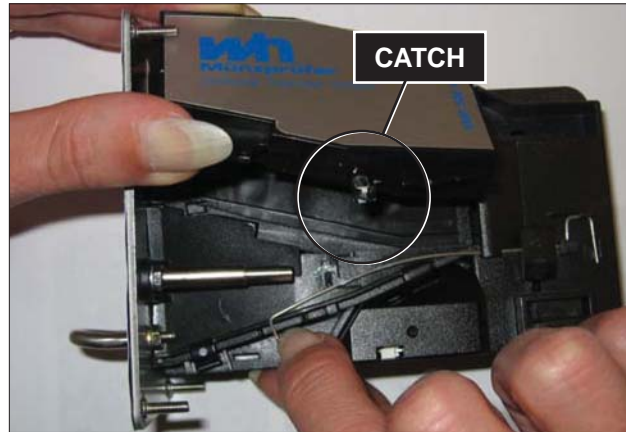

To open the selector move spring downwards to free the catch.





# Coin Micro Switch 20Lb. Non-Express: 120 Volt Wiring Schematic

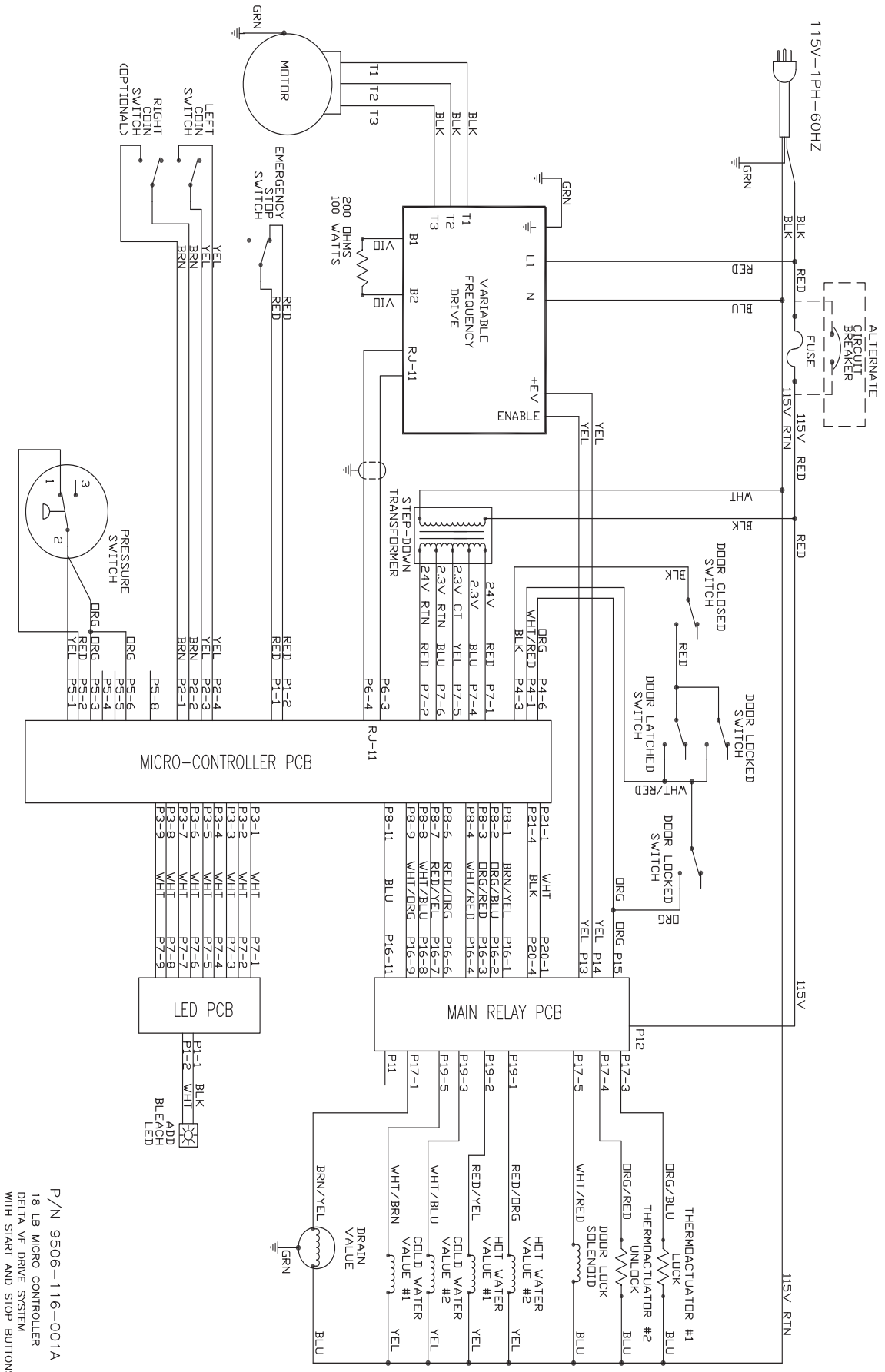

P/N 9506-116-001A  
18 LB MICRO CONTROLLER  
DELTA VFD DRIVE SYSTEM  
WITH START AND STOP BUTTONS

# Coin Micro Switch 20Lb. Non-Express: 120 Volt Wiring Diagram

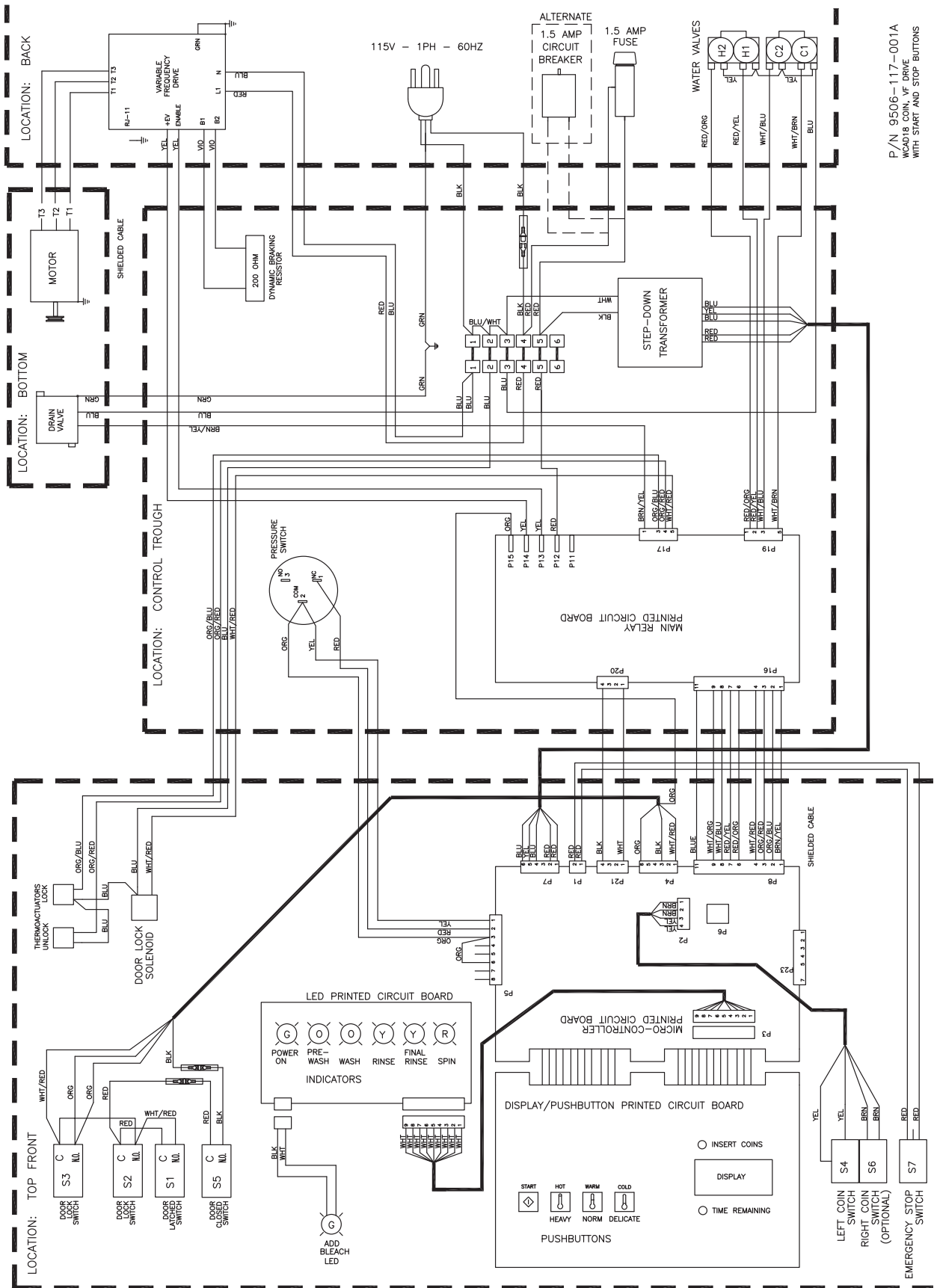

P/N 9506-117-001A  
W4018 COIN V.F. DRIVE  
WITH START AND STOP BUTTONS

# 20lb Non-Express: U.S. Optical Acceptor Schematic 120V

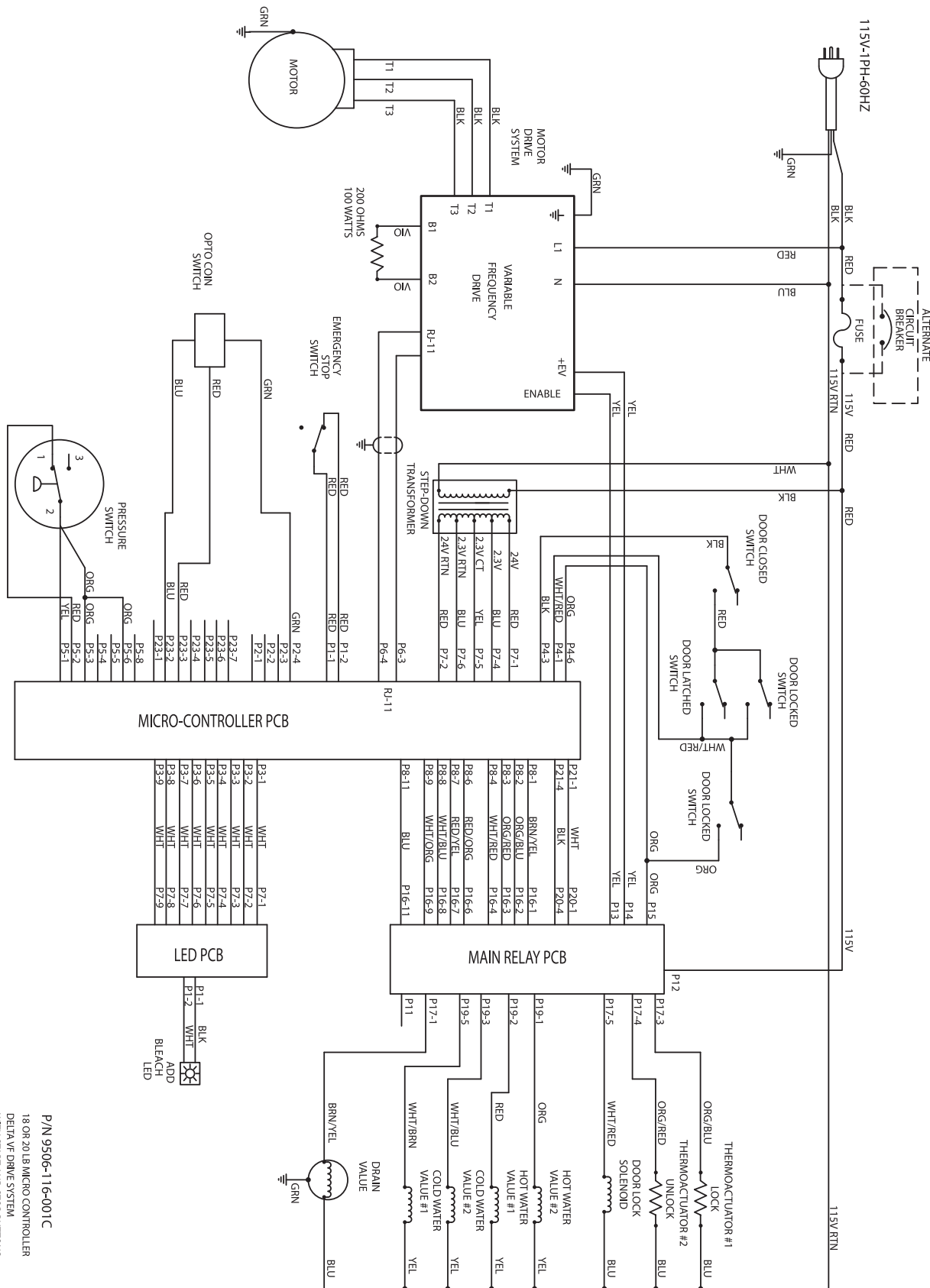

P/N 9506-116-001C  
 18 OR 20 LB MICRO-CONTROLLER  
 DELTA VFD DRIVE SYSTEM  
 WITH START AND STOP BUTTONS

# 20lb Non-Express: U.S Optical Acceptor Diagram 120V

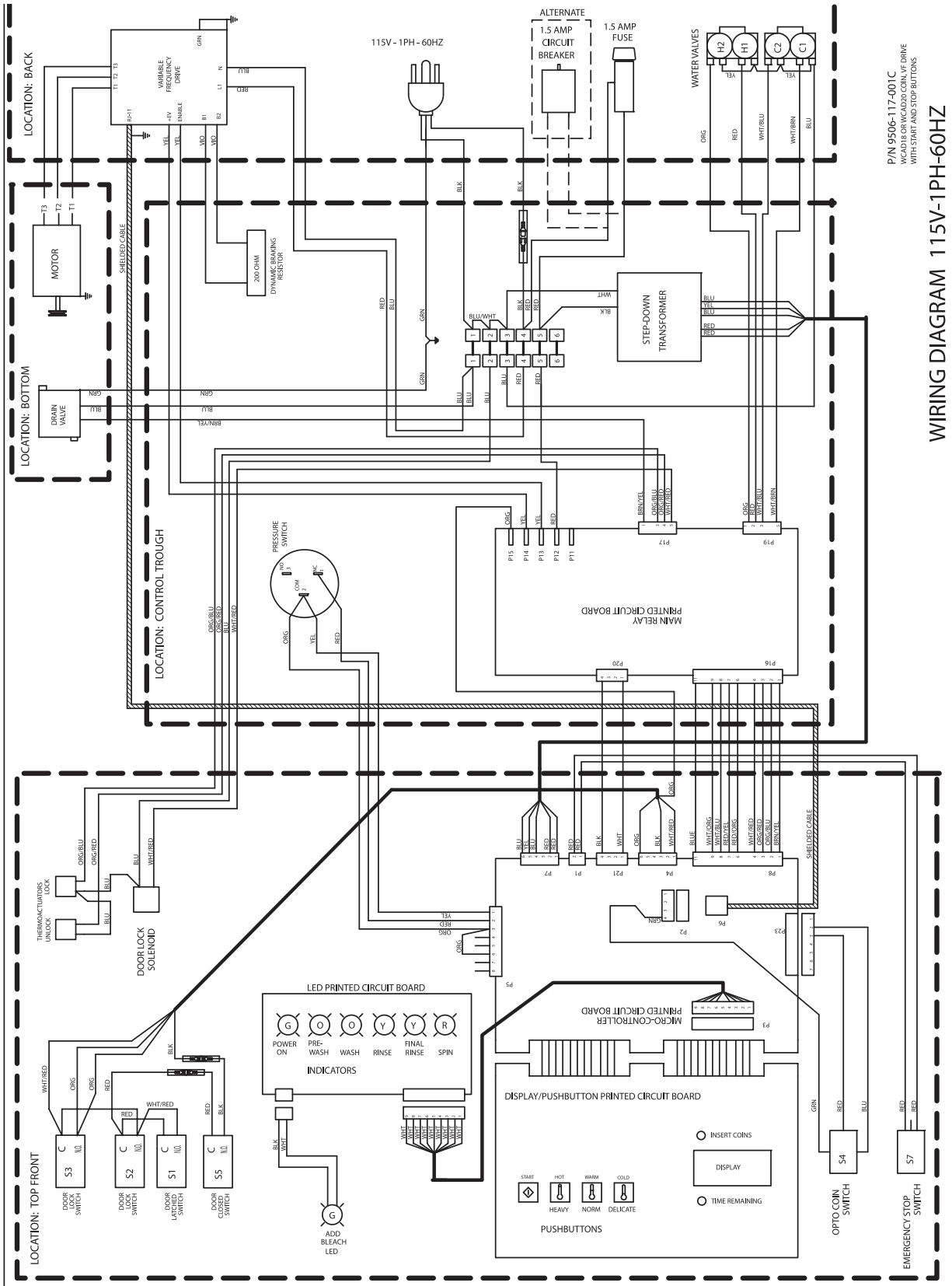

# 20lb Non-Express: Electronic Acceptor Schematic 120V

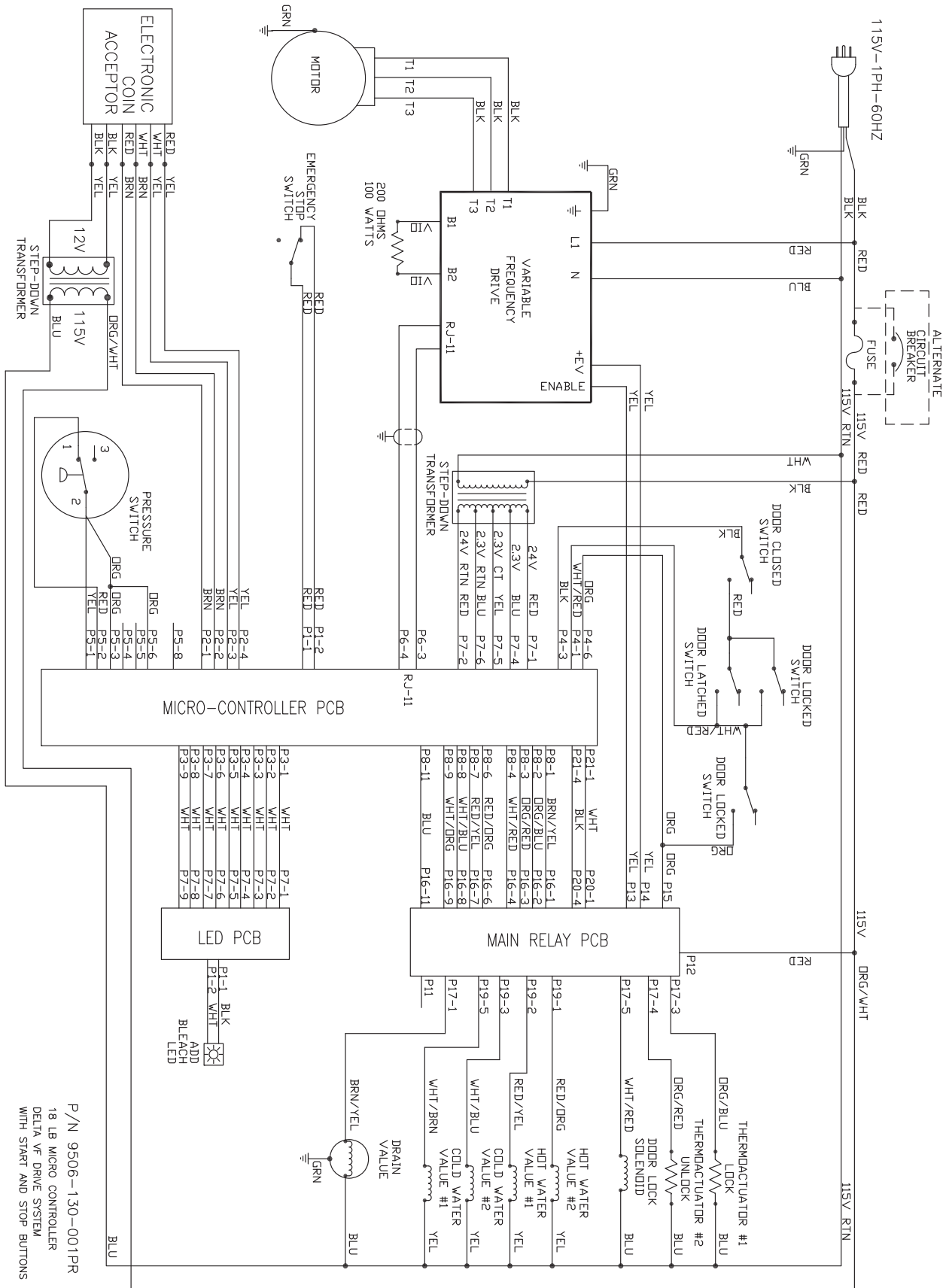

# 20lb Non-Express: Electronic Acceptor Wire Diagram 120V

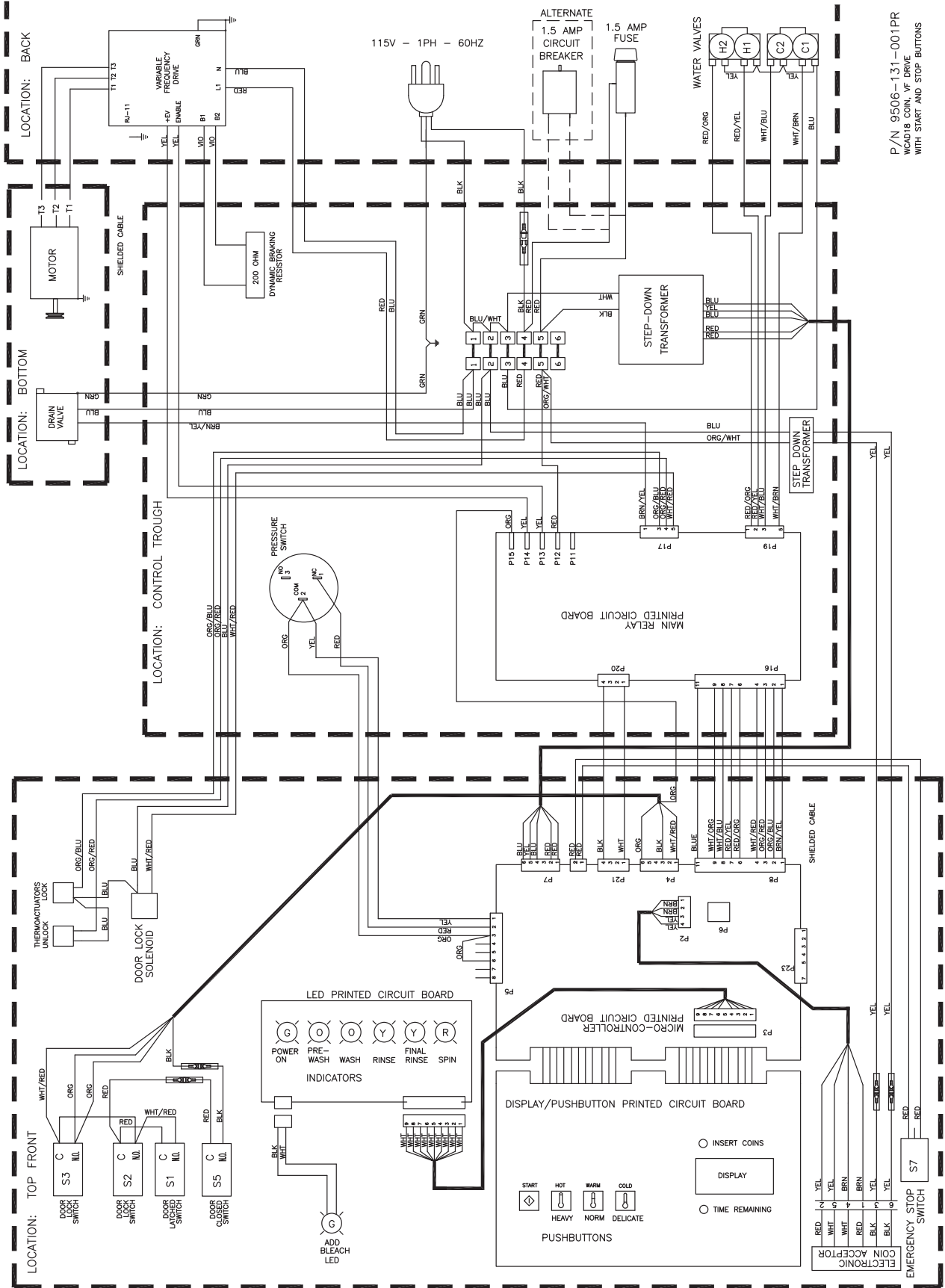

P/N 9506-131-001PR  
 WCA018 COIN VF DRIVE  
 WITH START AND STOP BUTTONS

# CN (No Coin Acceptor) 20Lb. Non-Express: 120 Volt Wiring Schematic

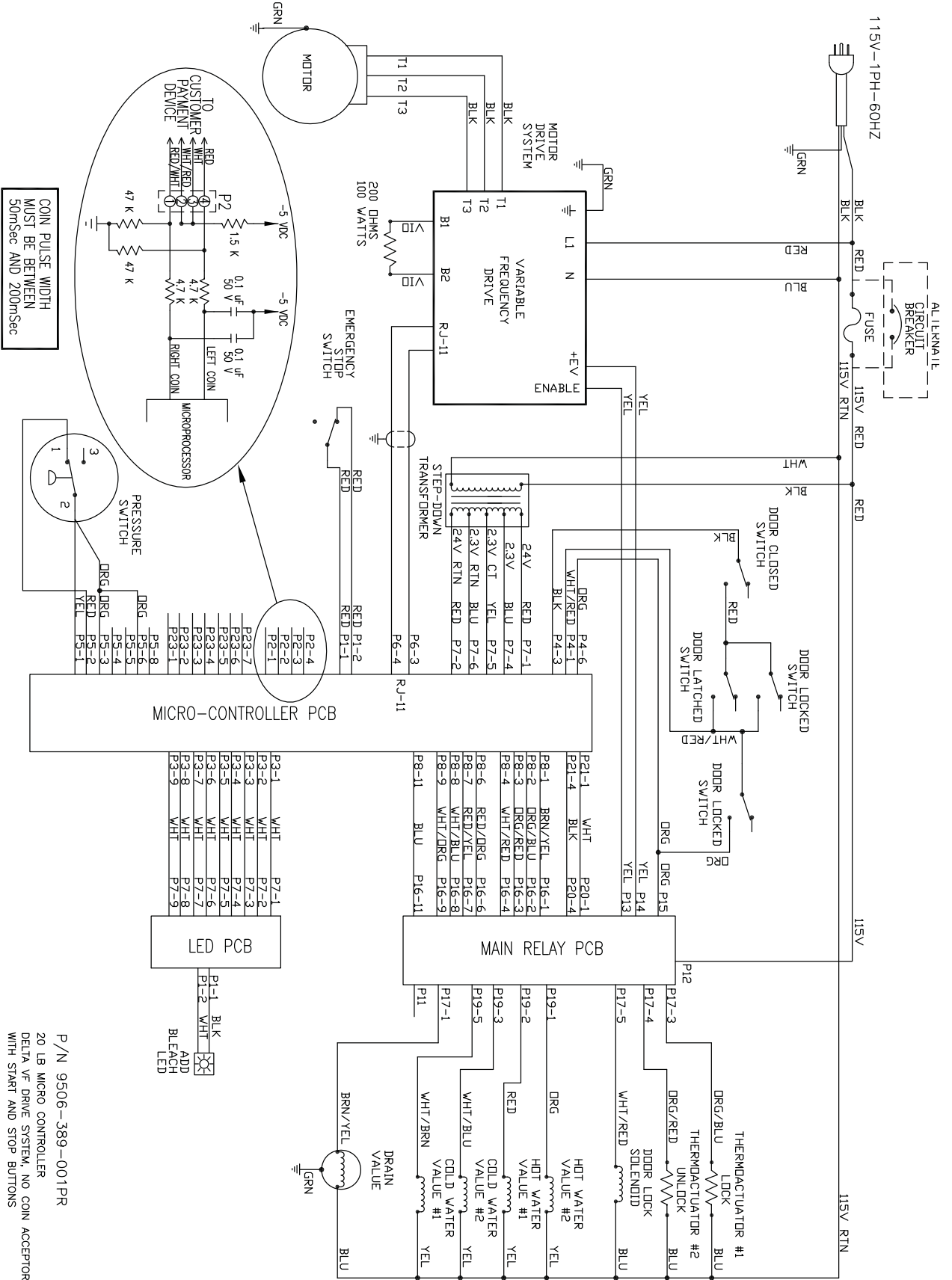

SCHEMATIC

P/N 9506-389-001PR  
20 LB MICRO CONTROLLER  
DELTA V<sup>F</sup> DRIVE SYSTEM, NO COIN ACCEPTOR  
WITH START AND STOP BUTTONS  
115-1PH-60HZ



# CN (No Coin Acceptor) 20Lb. Non-Express: 120 Volt Wiring Diagram

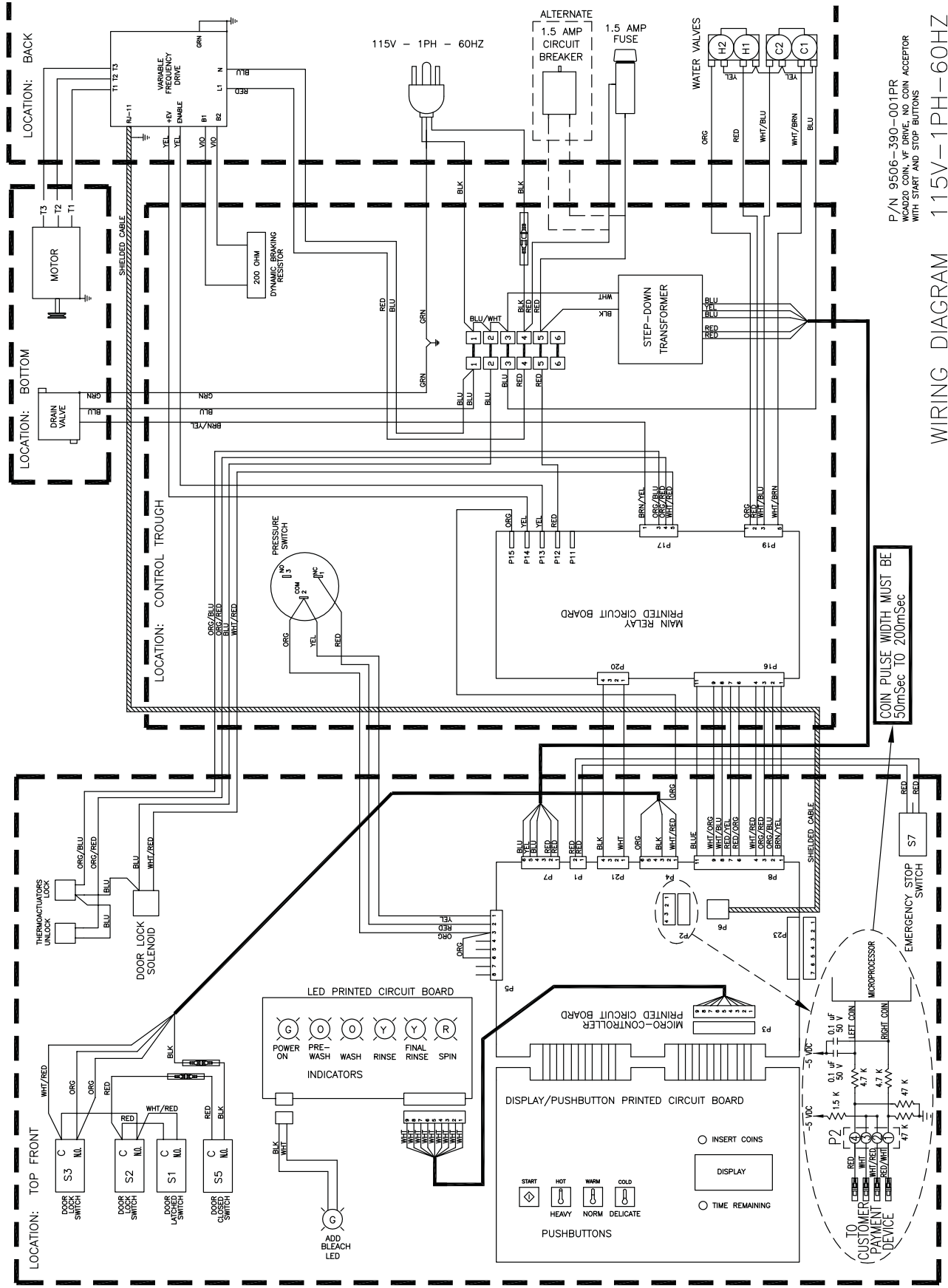

P/N 9506-390-001PR  
W4020 COIN. VF DRIVE, NO COIN ACCEPTOR  
WITH START AND STOP BUTTONS

WIRING DIAGRAM 115V-1PH-60HZ

# Coin Micro Switch 20Lb. Non-Express: 208-240 Volt Wiring Schematic

208-240V-3PH OR 1PH-60HZ

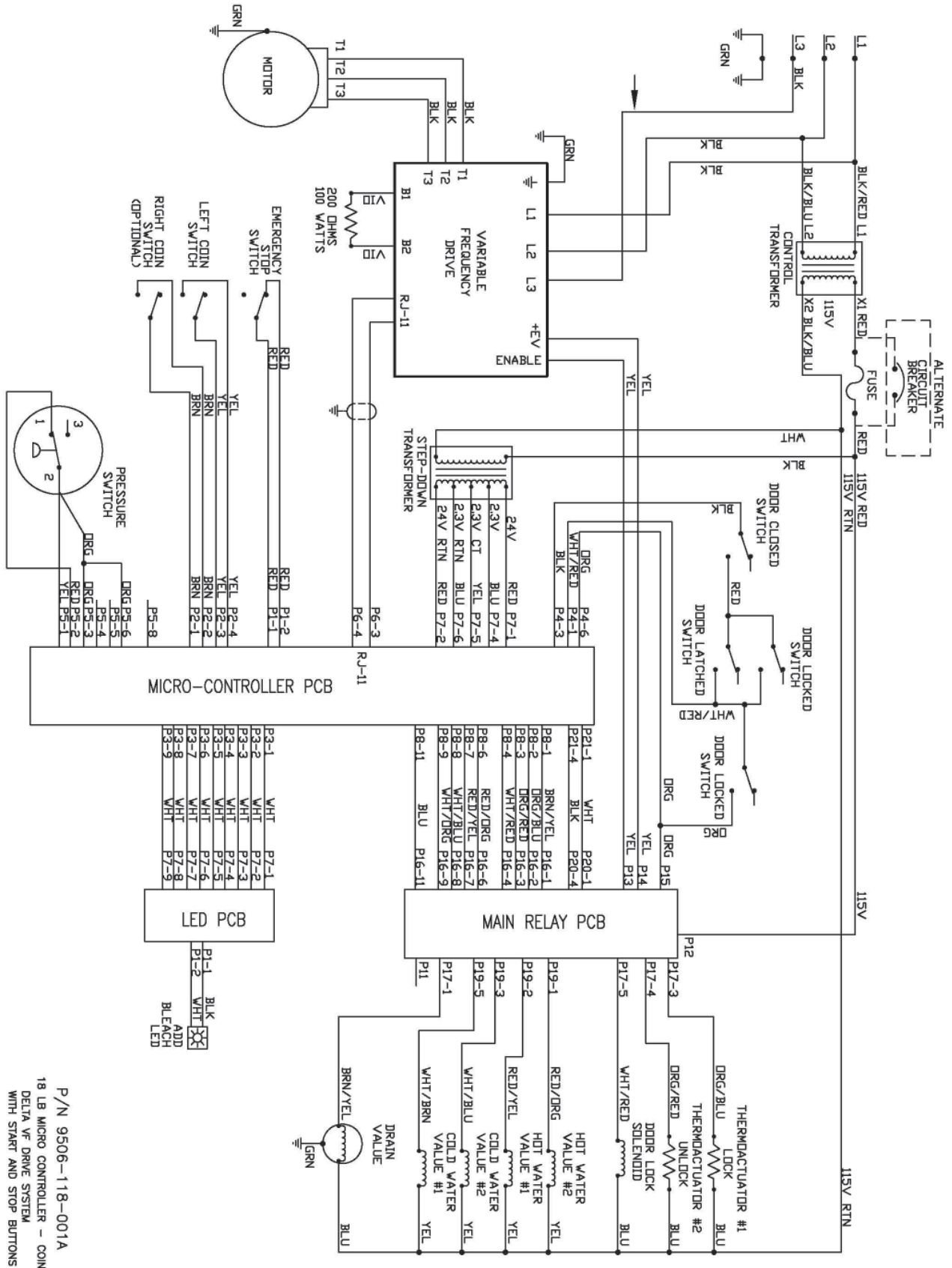

P/N 9506-118-001A  
18 LB MICRO CONTROLLER - COIN  
DELTA VF DRIVE SYSTEM  
WITH START AND STOP BUTTONS

# Coin Micro Switch 20Lb. Non-Express: 208-240 Volt Wiring Diagram

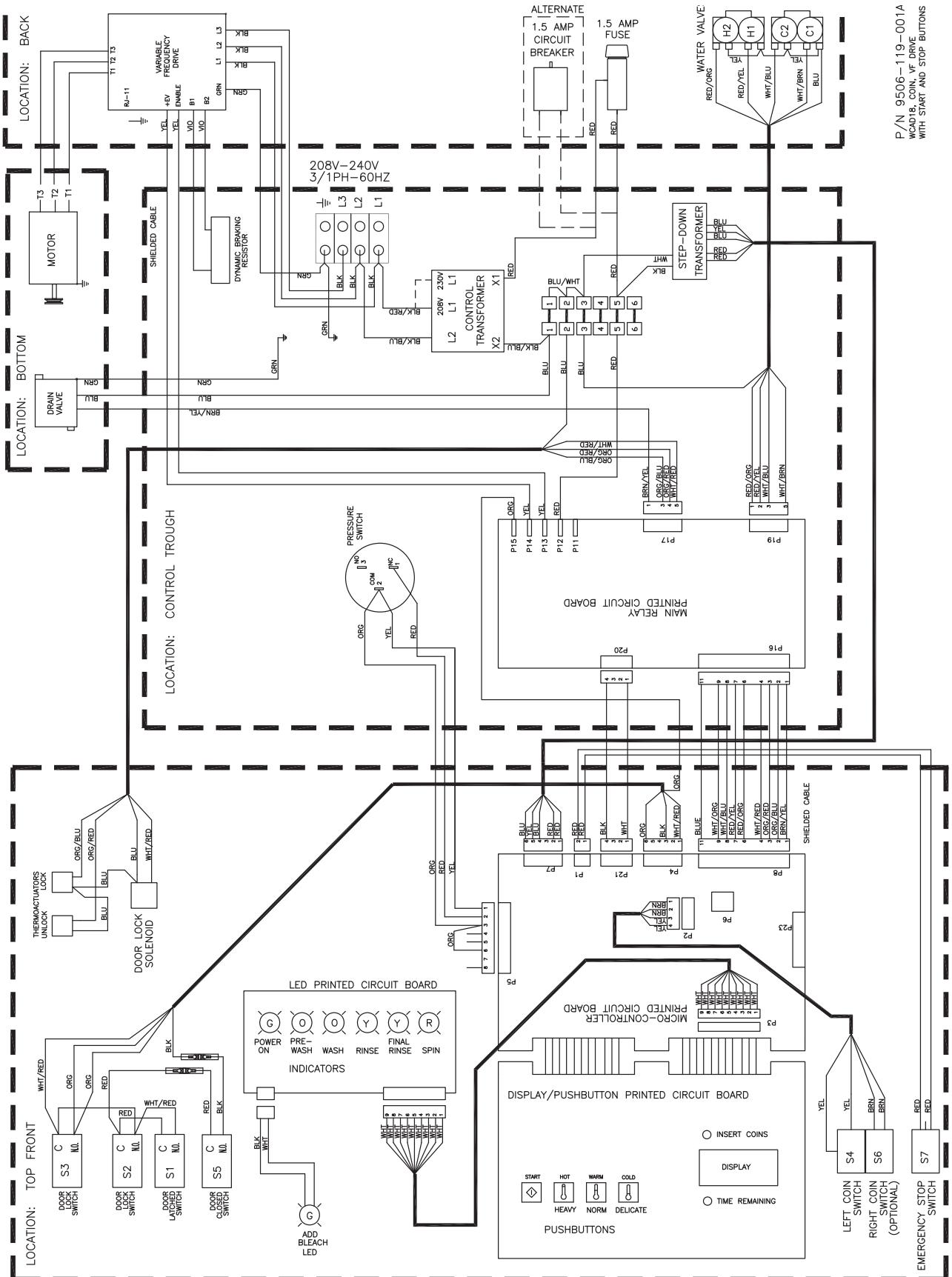

P/N 9506-119-001A  
W04018, COIN, VF DRIVE  
WITH START AND STOP BUTTONS

# 20lb. Non-Express: U.S Optical Acceptor Schematic 208-240V

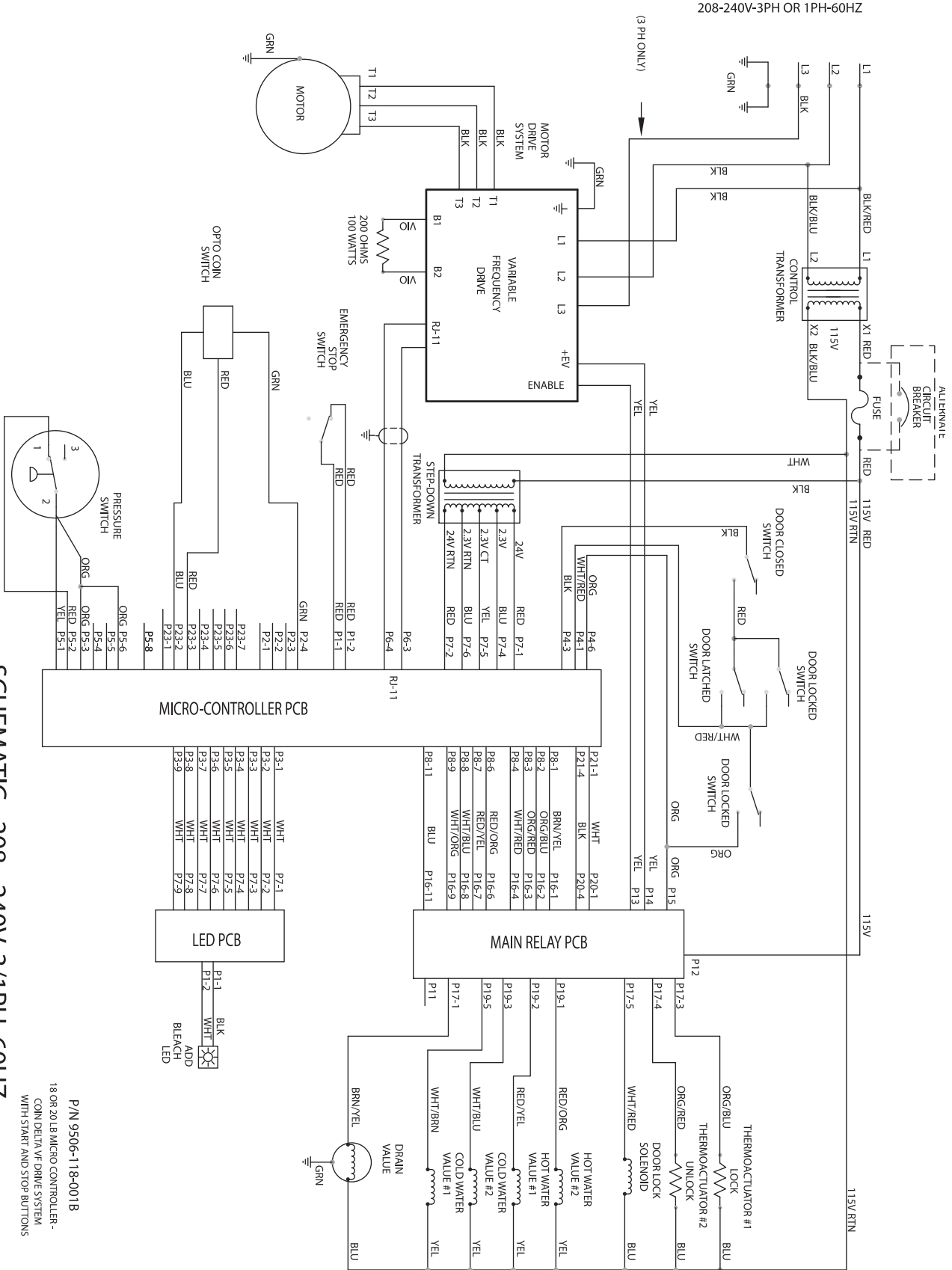

# 20lb. Non-Express: U.S Optical Acceptor Diagram 208-240V

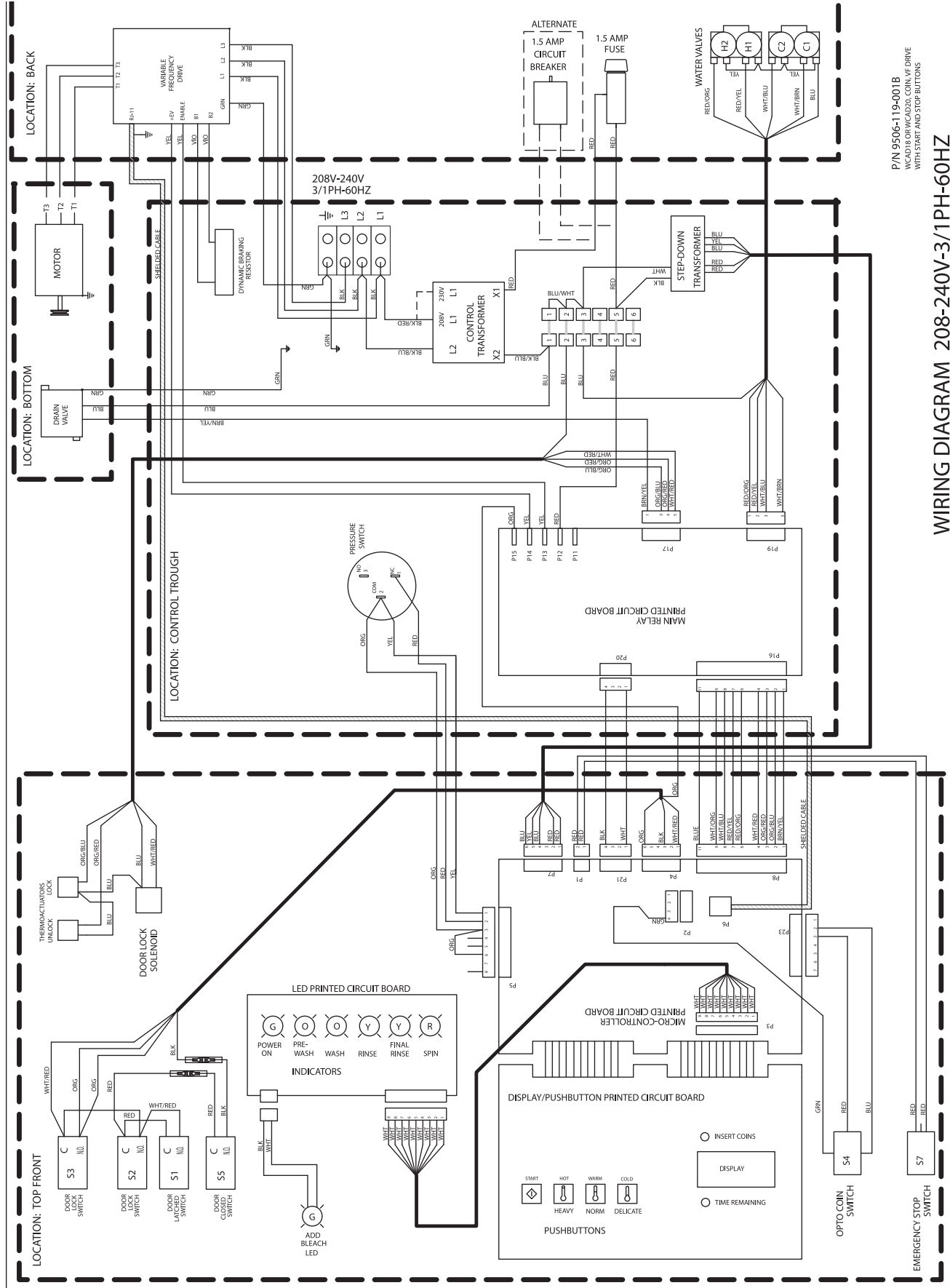

P/N 9506-119-001B  
 WC4018 OR WC4026, COIN V.F. DRIVE  
 WITH START AND STOP BUTTONS

WIRING DIAGRAM 208-240V-3/1PH-60HZ

# 20lb. Non-Express: Electronic Acceptor Schematic 208-240V

208-240V-3PH OR 1PH-60HZ

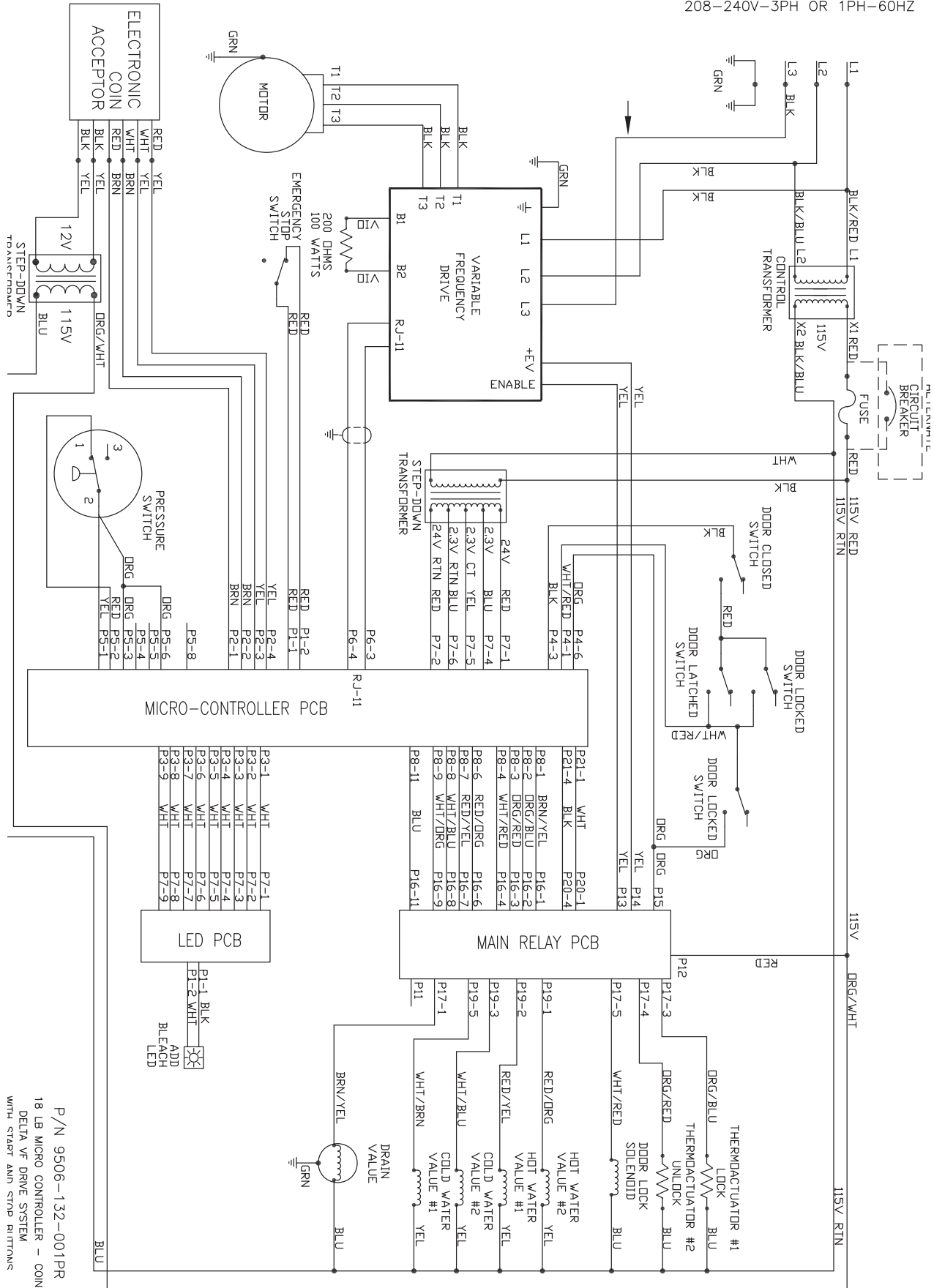

P/N 9506-132-001PR  
 18 LB MICRO CONTROLLER - COIN  
 DELTA VF DRIVE SYSTEM  
 WITH START AND STOP BUTTONS

# 20lb. Non-Express: Electronic Acceptor Diagram 208-240V

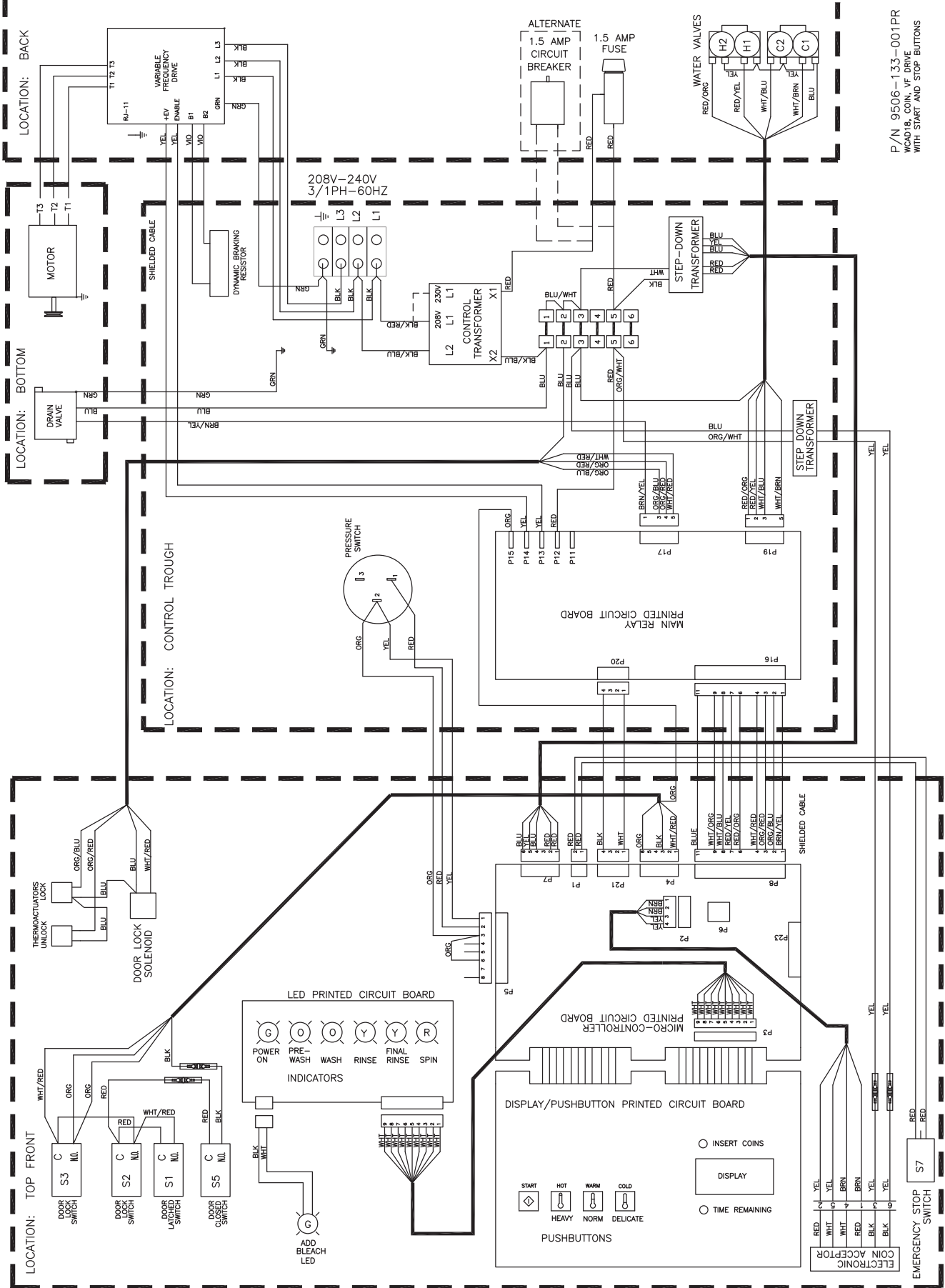

P/N 9506-133-001PR  
WCAD18, COIN VF DRIVE  
WITH START AND STOP BUTTONS

# CN (No Coin Acceptor) 20Lb. Non-Express: 208-240V Schematic

208-240V-3PH OR 1PH-60HZ

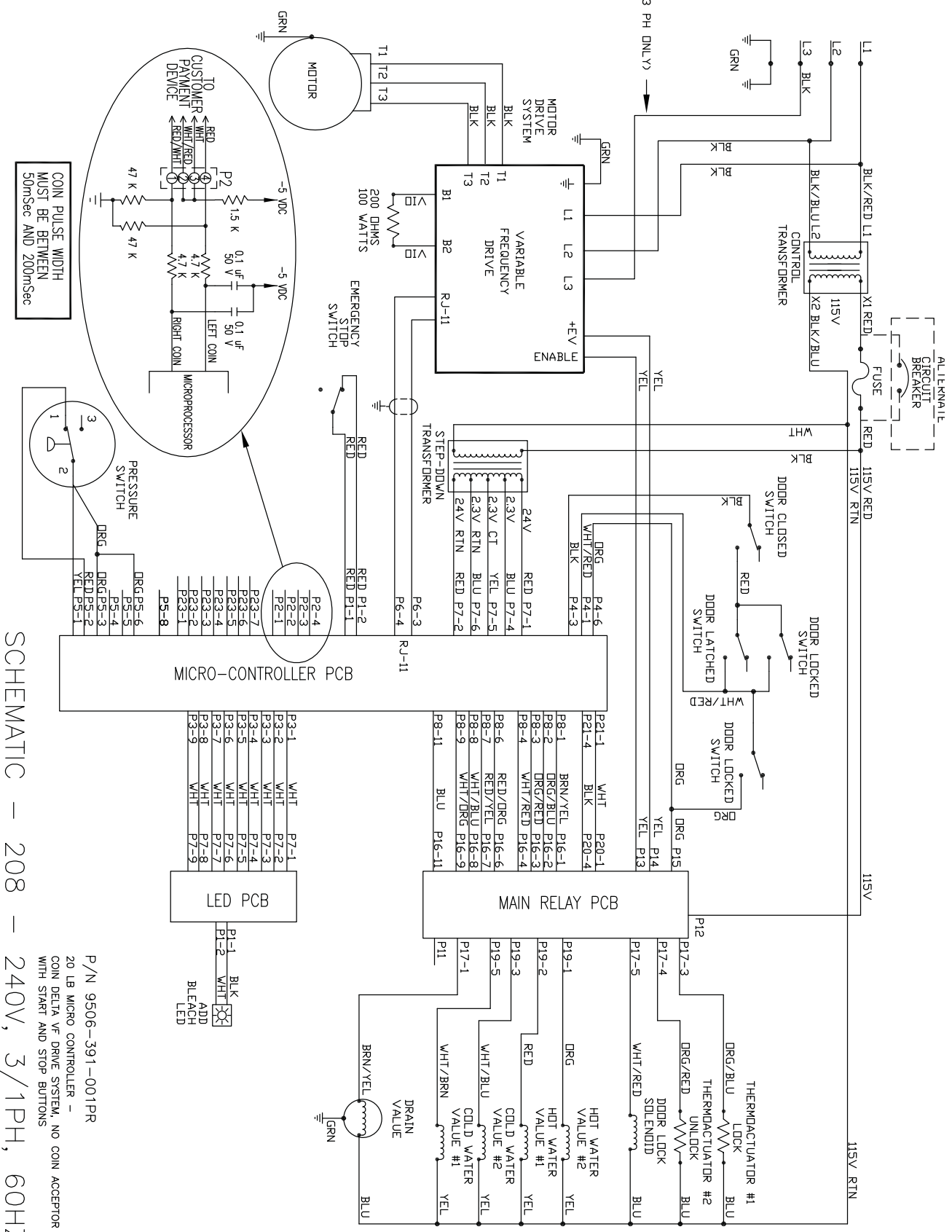

SCHEMATIC - 208 - 240V, 3/1PH, 60HZ

P/N 9506-391-001PR  
20 LB MICRO CONTROLLER -  
COIN DELTA VF DRIVE SYSTEM, NO COIN ACCEPTOR  
WITH START AND STOP BUTTONS



# CN (No Coin Acceptor) 20Lb. Non-Express: 208-240 Volt Wiring Diagram

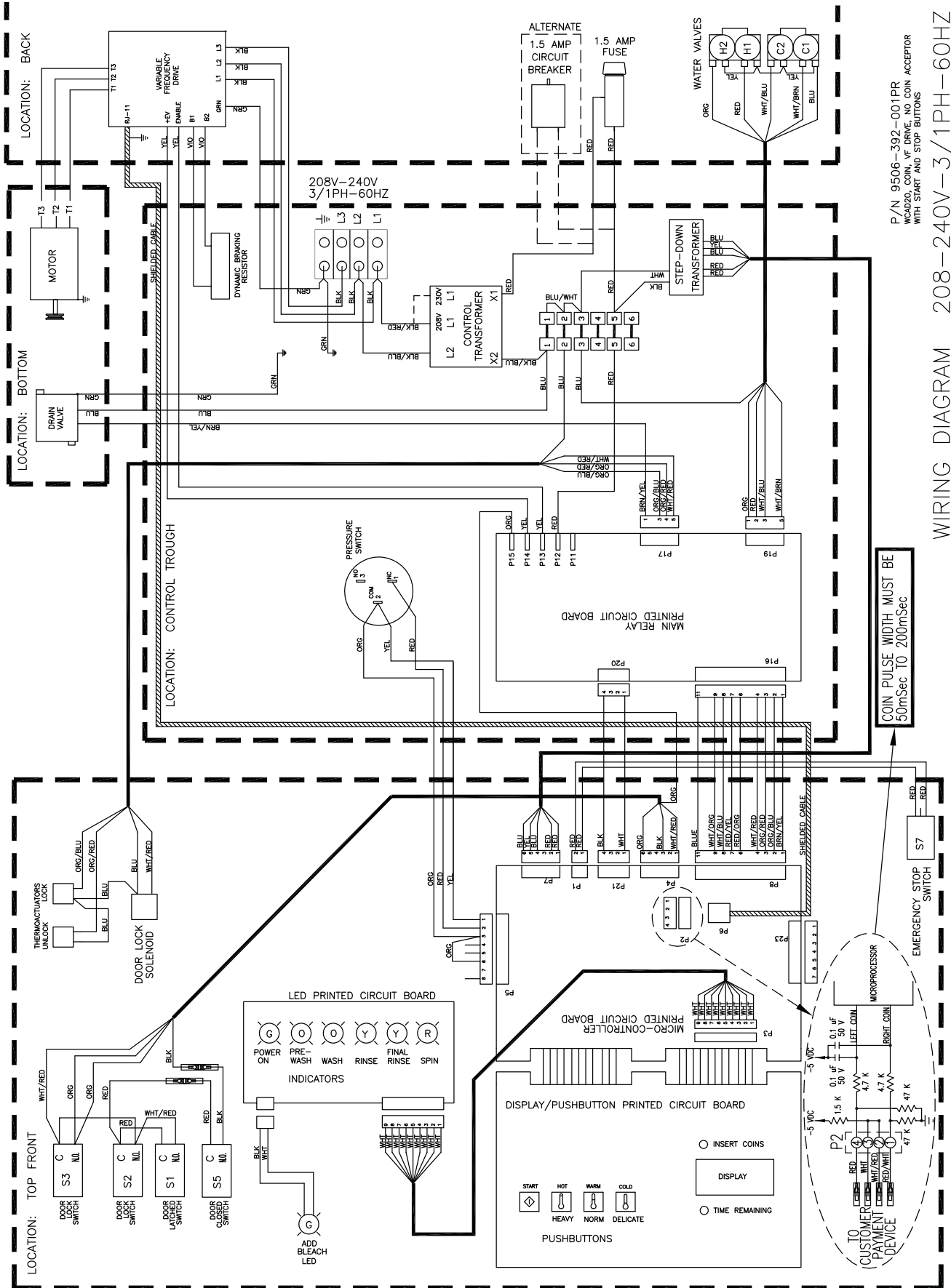

P/N 9506-392-001 PR  
WAS 9506-392-001 PR  
WITH START AND STOP BUTTONS

WIRING DIAGRAM 208-240V-3/1PH-60HZ

COIN PULSE WIDTH MUST BE  
50mSec TO 200mSec

# 20lb Express: Micro Switch Acceptor Schematic 208-240V

208-240V-3PH OR 1PH-60HZ

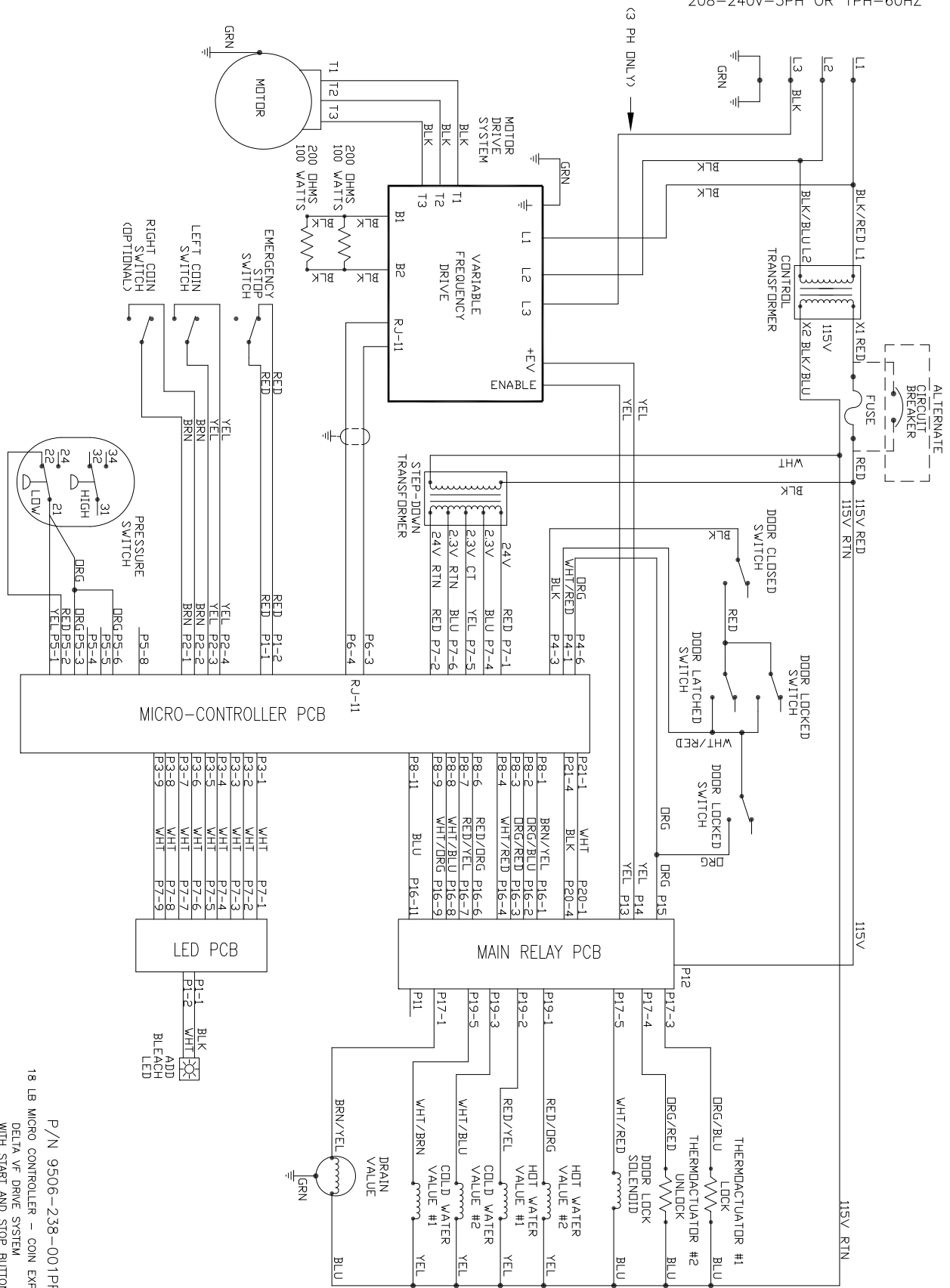

SCHEMATIC - 208 - 240V, 3/1PH, 60HZ

P/N 9506-238-001PR  
 18 LB MICRO CONTROLLER - COIN EXPRESS  
 DELTA V.F. DRIVE SYSTEM  
 WITH START AND STOP BUTTONS

# 201b Express: Micro Switch Acceptor Diagram 208-240V

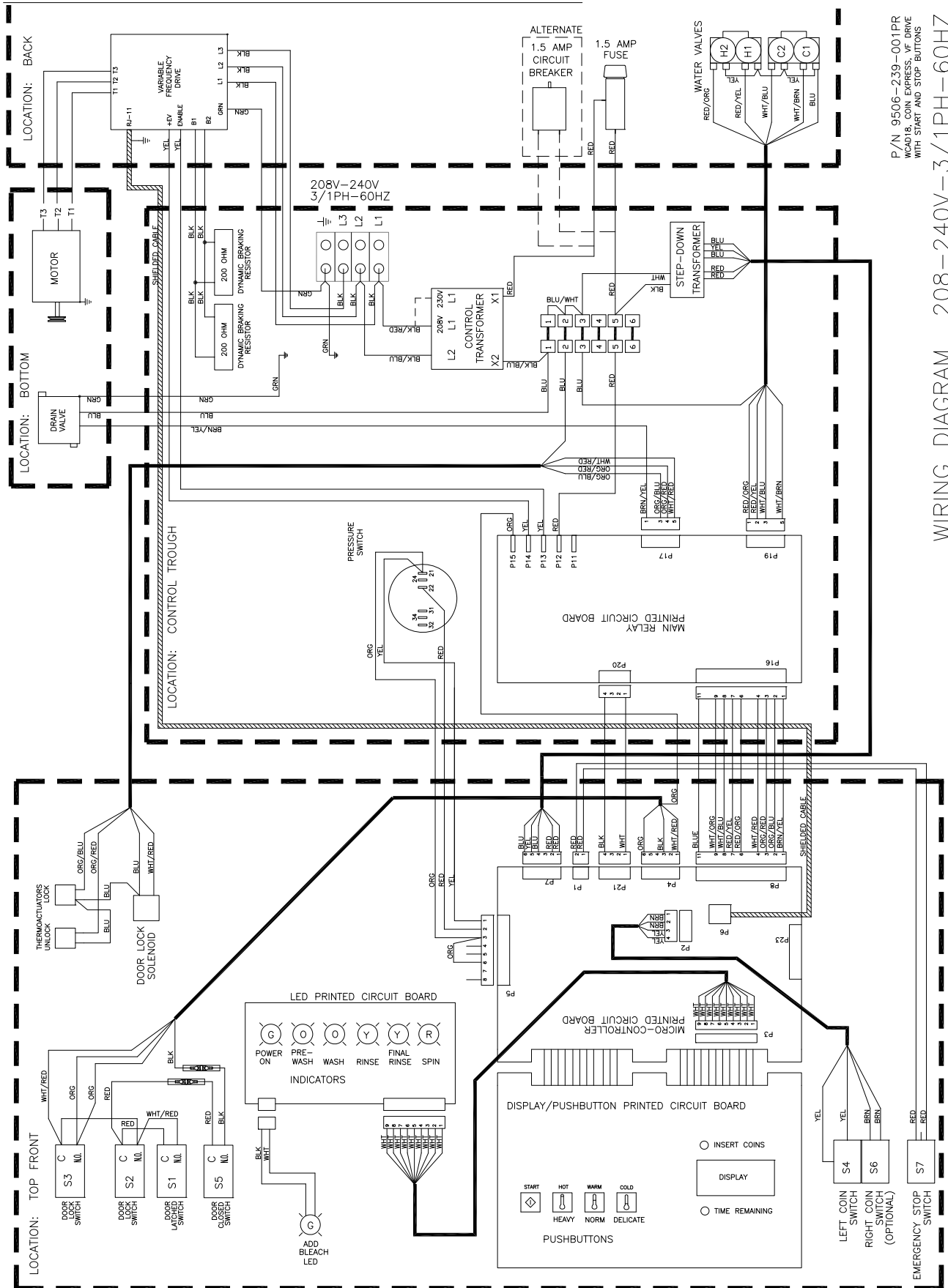

P/N 9506-239-001PR  
 WC418, COIN EXPRESS, VF DRIVE  
 WITH START AND STOP BUTTONS

WIRING DIAGRAM 208-240V-3/1PH-60HZ

# 20lb Express: U.S Optical Acceptor Schematic 208-240V

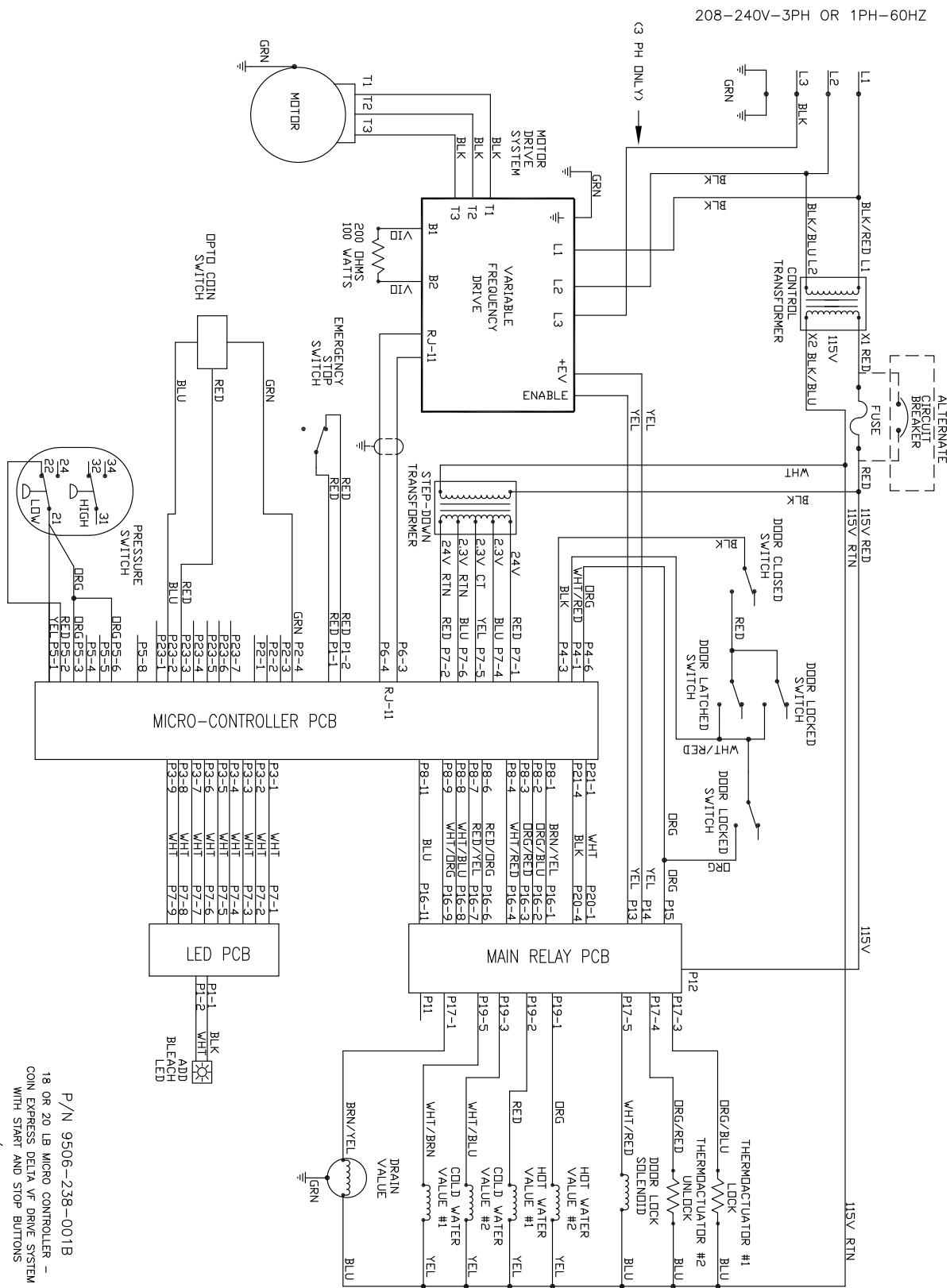

SCHEMATIC - 208 - 240V, 3/1PH, 60HZ

P/N 9506-238-001B  
 18 OR 20 LB MICRO CONTROLLER -  
 COIN EXPRESS DELTA V.F. DRIVE SYSTEM  
 WITH START AND STOP BUTTONS

# 20lb Express: U.S Optical Acceptor Diagram 208-240V

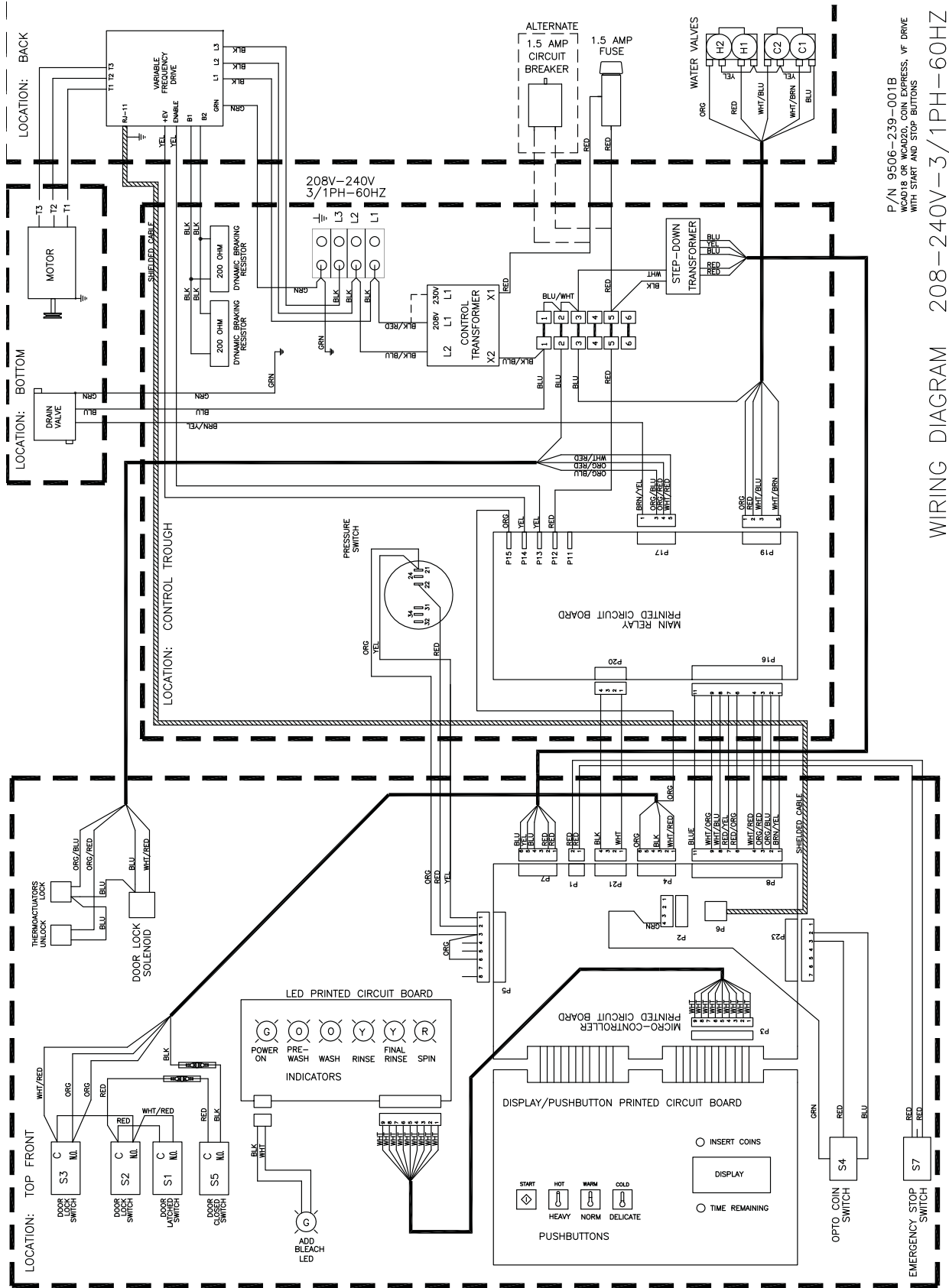

P/N 9506-239-001B  
 W4018 OR W4020 CON EXPRESS, VF DRIVE  
 WITH START AND STOP BUTTONS

WIRING DIAGRAM 208-240V-3/1PH-60HZ

# 20lb Express: Electronic Acceptor Schematic 208-240V

208-240V-3PH OR 1PH-60HZ

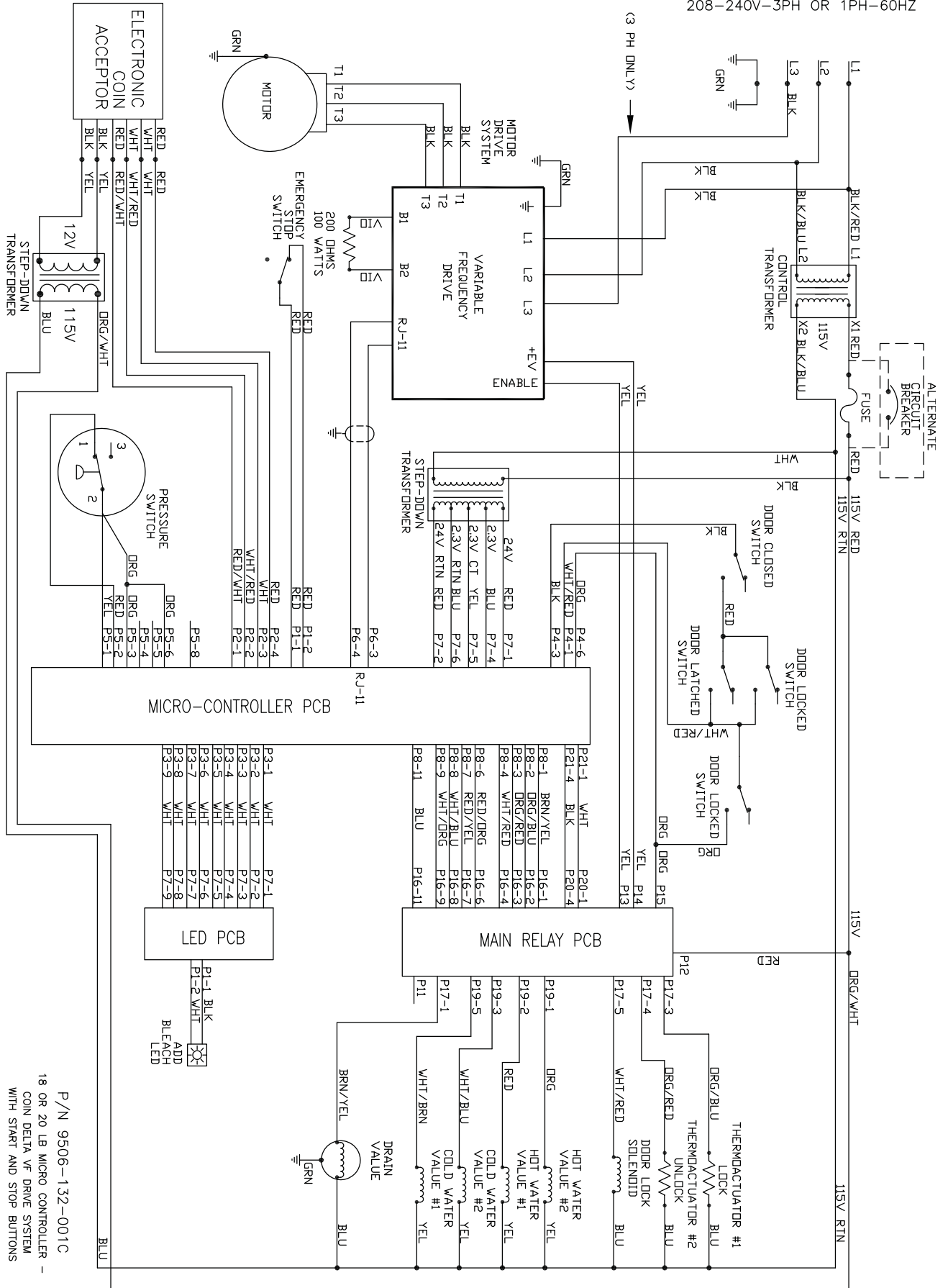

SCHEMATIC - 1 OR 3 PH/60HZ/208 - 240V

P/N 9506-132-001C  
 18 OR 20 LB MICRO CONTROLLER -  
 COIN DELTA VF DRIVE SYSTEM  
 WITH START AND STOP BUTTONS

# 20lb Express: Electronic Acceptor Diagram 208-240V

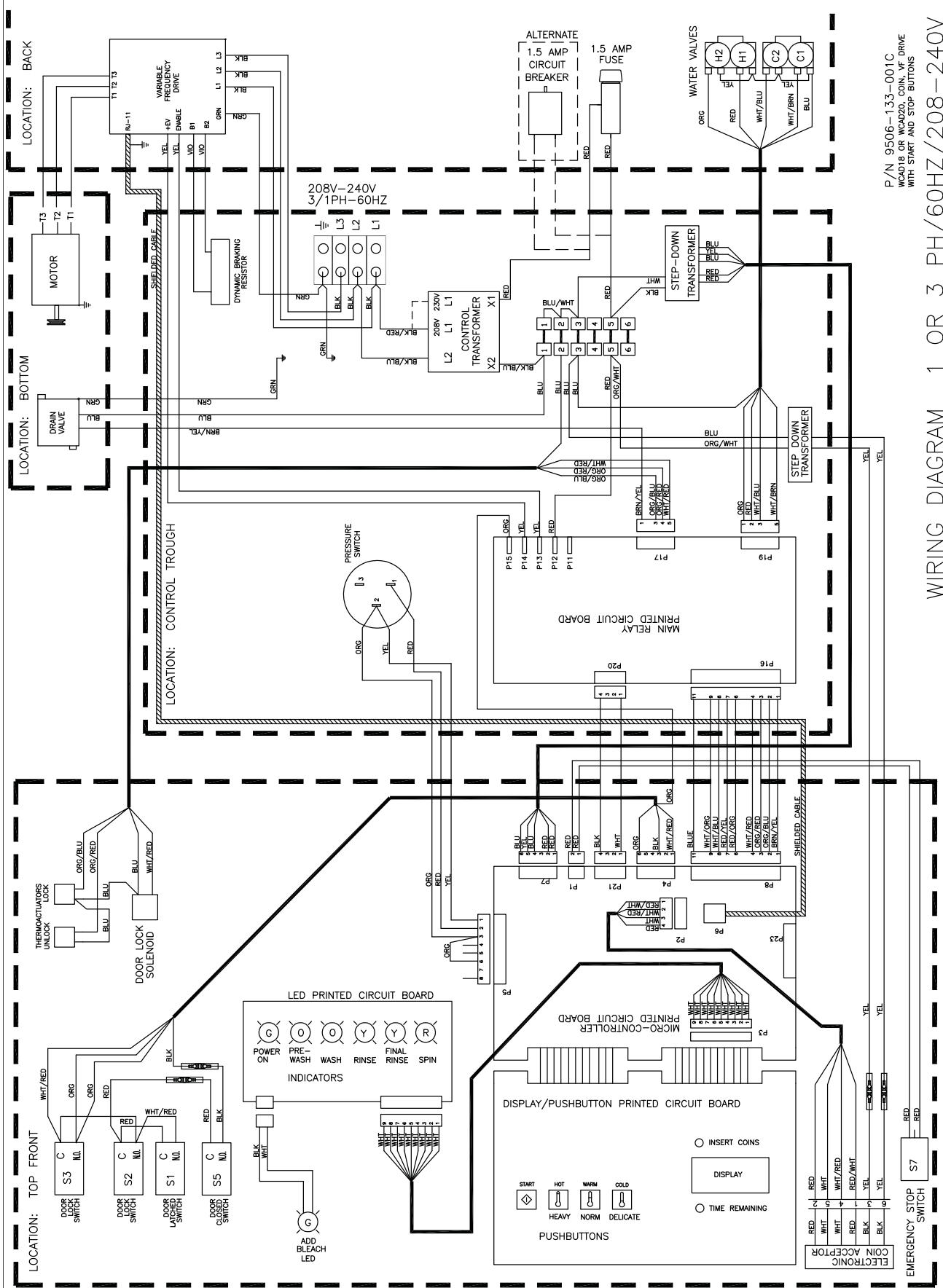

P/N 9506-133-001C  
 WCA018 OR WCA020, COIN VF DRIVE  
 WITH START AND STOP BUTTONS

WIRING DIAGRAM 1 OR 3 PH/60HZ/208-240V

# CN (No Coin Acceptor) 20Lb. Express: 208-240 Wiring Schematic

208-240V-3PH OR 1PH-60HZ

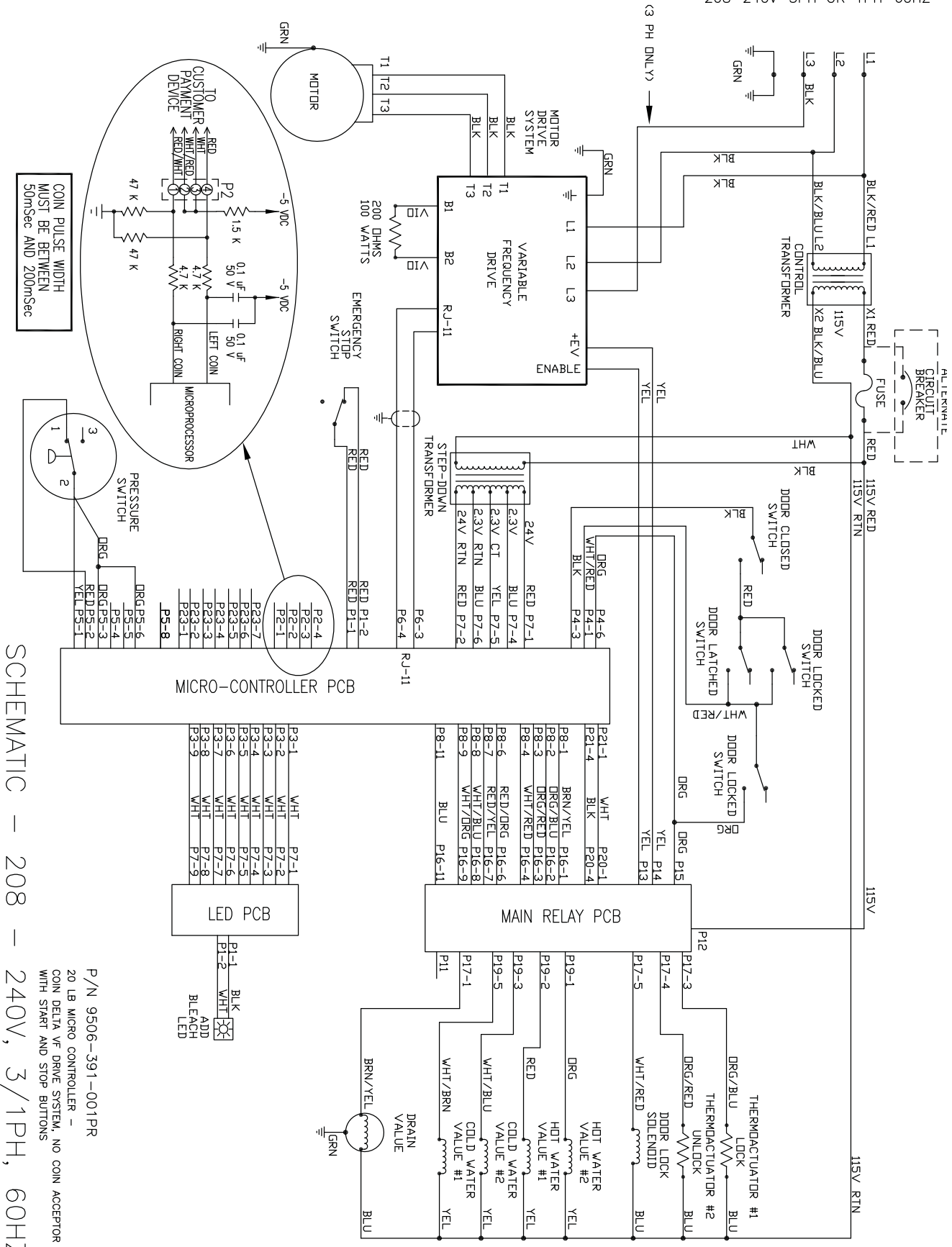

P/N 9506-391-001PR  
20 LB MICRO CONTROLLER -  
COIN DELTA VF DRIVE SYSTEM, NO COIN ACCEPTOR  
WITH START AND STOP BUTTONS



# CN (No Coin Acceptor) 20Lb. Express: 208-240 Wiring Diagram

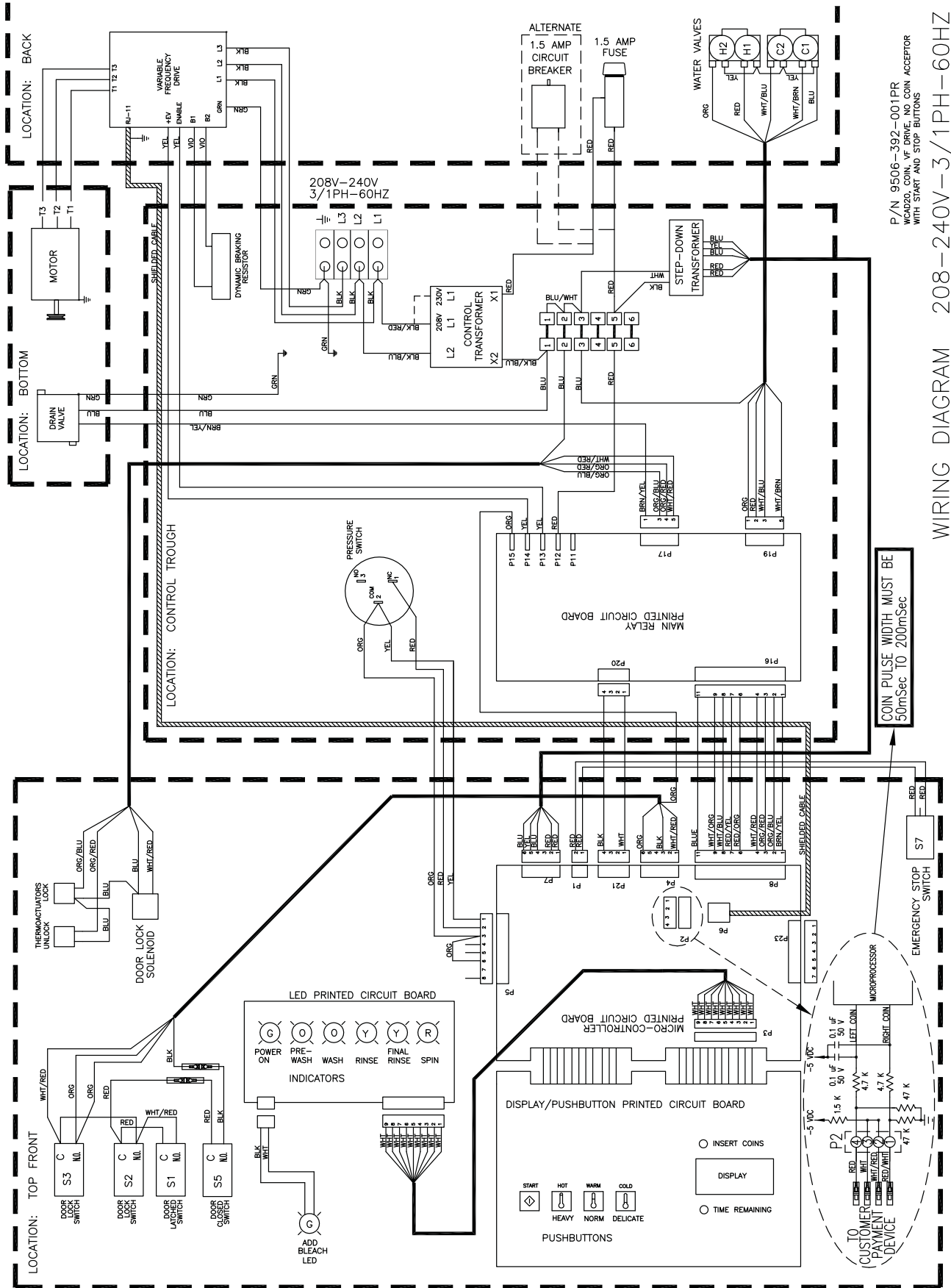

P/N 9506-392-001PR  
W/COIN ACCEPTOR  
W/START AND STOP BUTTONS

WIRING DIAGRAM 208-240V-3/1PH-60HZ

COIN PULSE WIDTH MUST BE  
50mSec TO 200mSec

# Coin Micro Switch 30Lb. Express: Non-Express Schematic

208-240V-3PH OR 1PH-60HZ

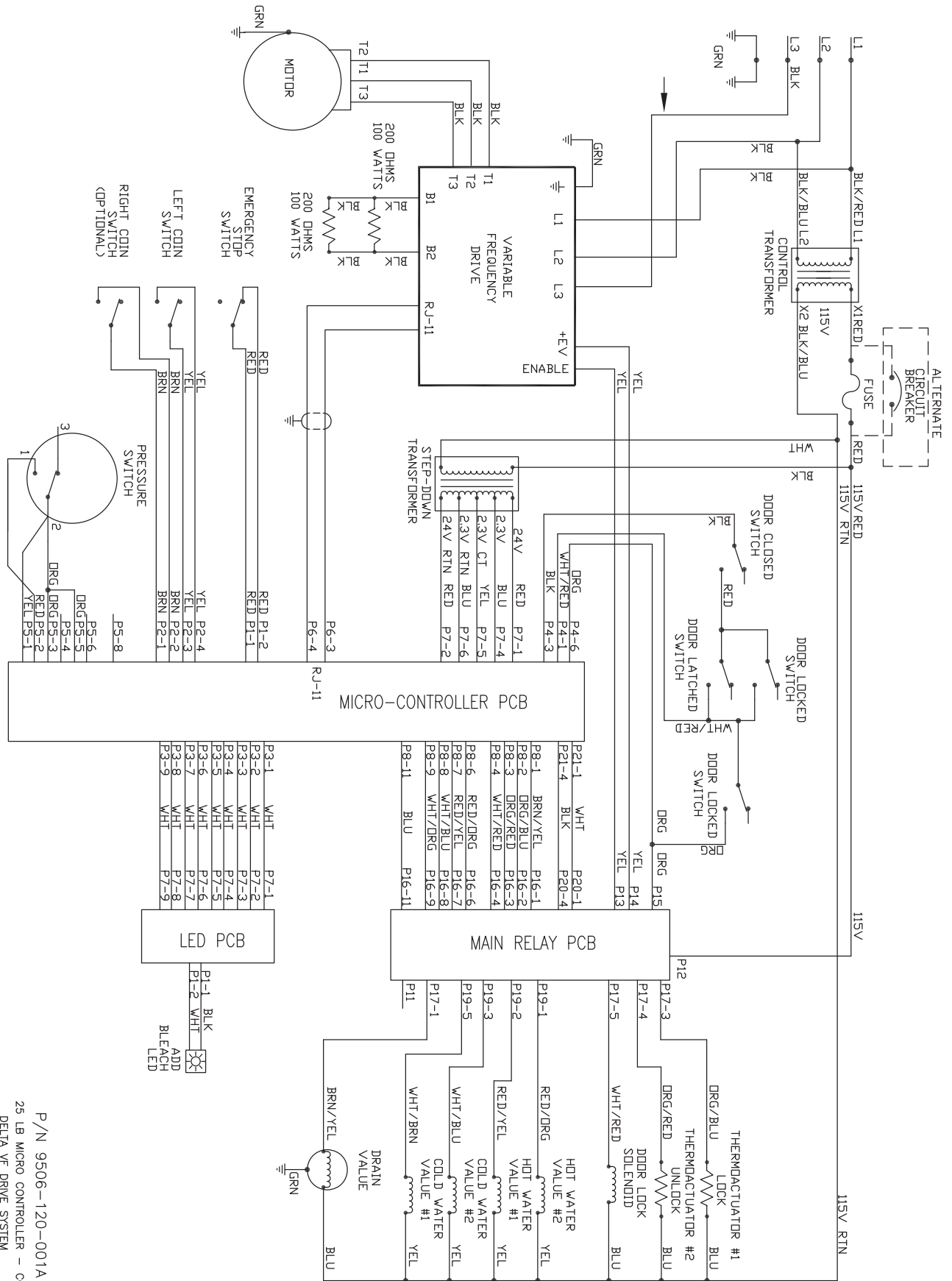

P/N 9506-120-001A  
 25 LB MICRO CONTROLLER - COIN  
 DELTA VF DRIVE SYSTEM  
 WITH START AND STOP BUTTONS

# Coin Micro Switch 30Lb. Express: Non-Express Diagram

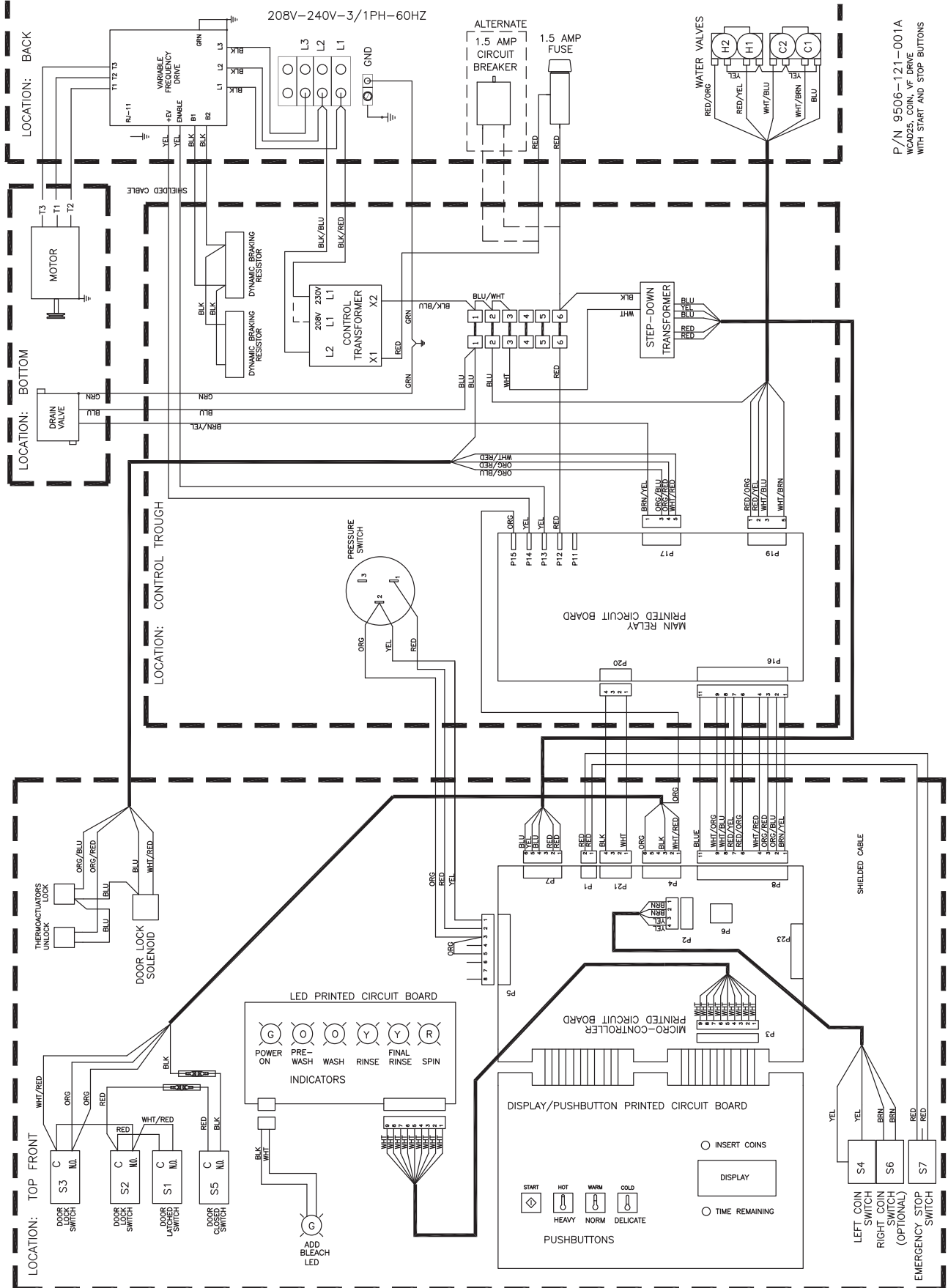

P/N 9506-121-001A  
 W44255 COIN MFC DRIVE  
 WITH START AND STOP BUTTONS

# 30Lb. Express & Non-Express: U.S. Optical Acceptor Schematic 208-240V

208-240V-3PH OR 1PH-60HZ

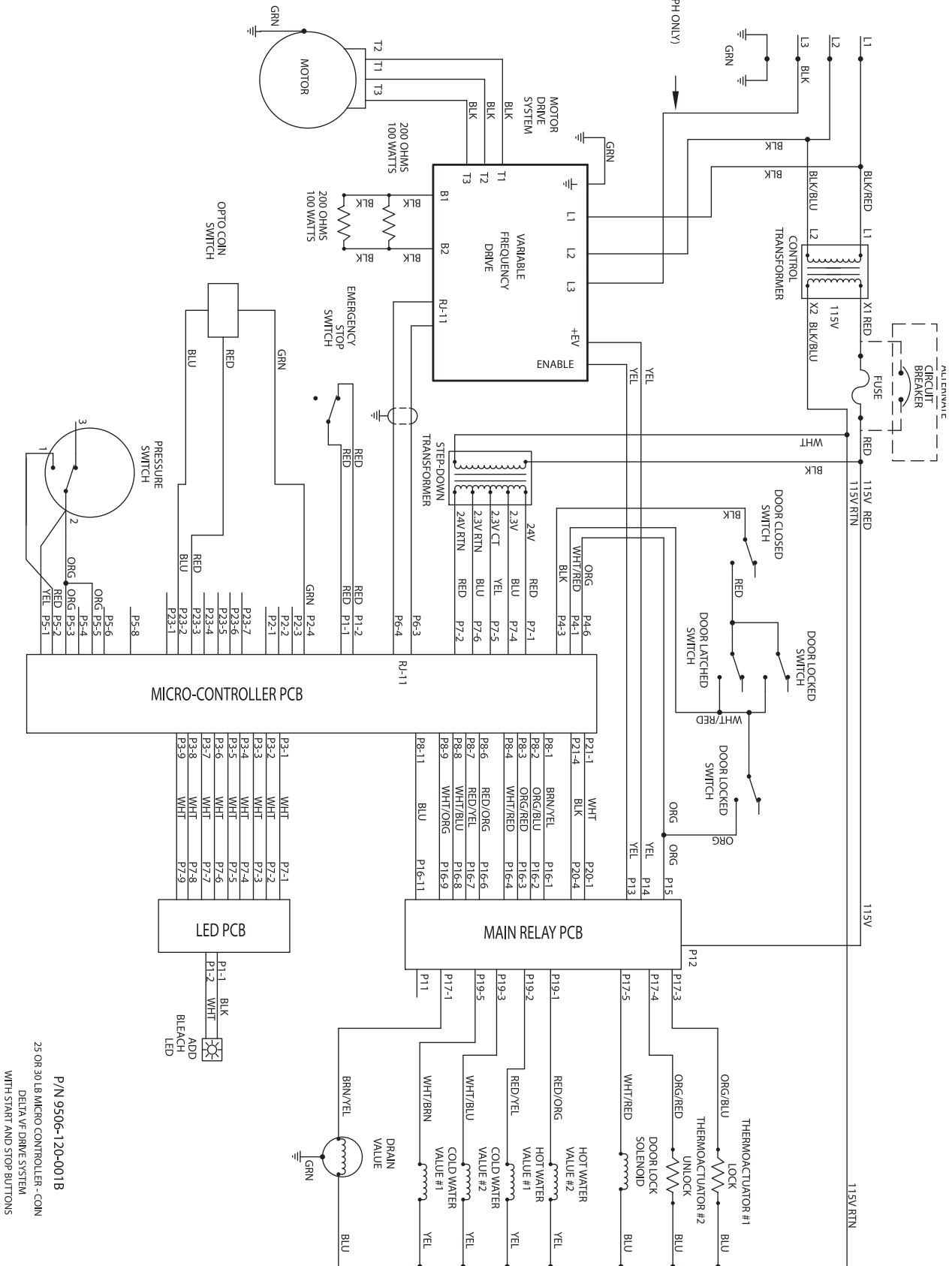

P/N 9506-120-001B  
 Z5 OR 30 LB MICRO CONTROLLER - COIN  
 DELTA V.F. DRIVE SYSTEM  
 WITH START AND STOP BUTTONS

# 30Lb. Express & Non-Express: U.S. Optical Acceptor

## Diagram 208-240V

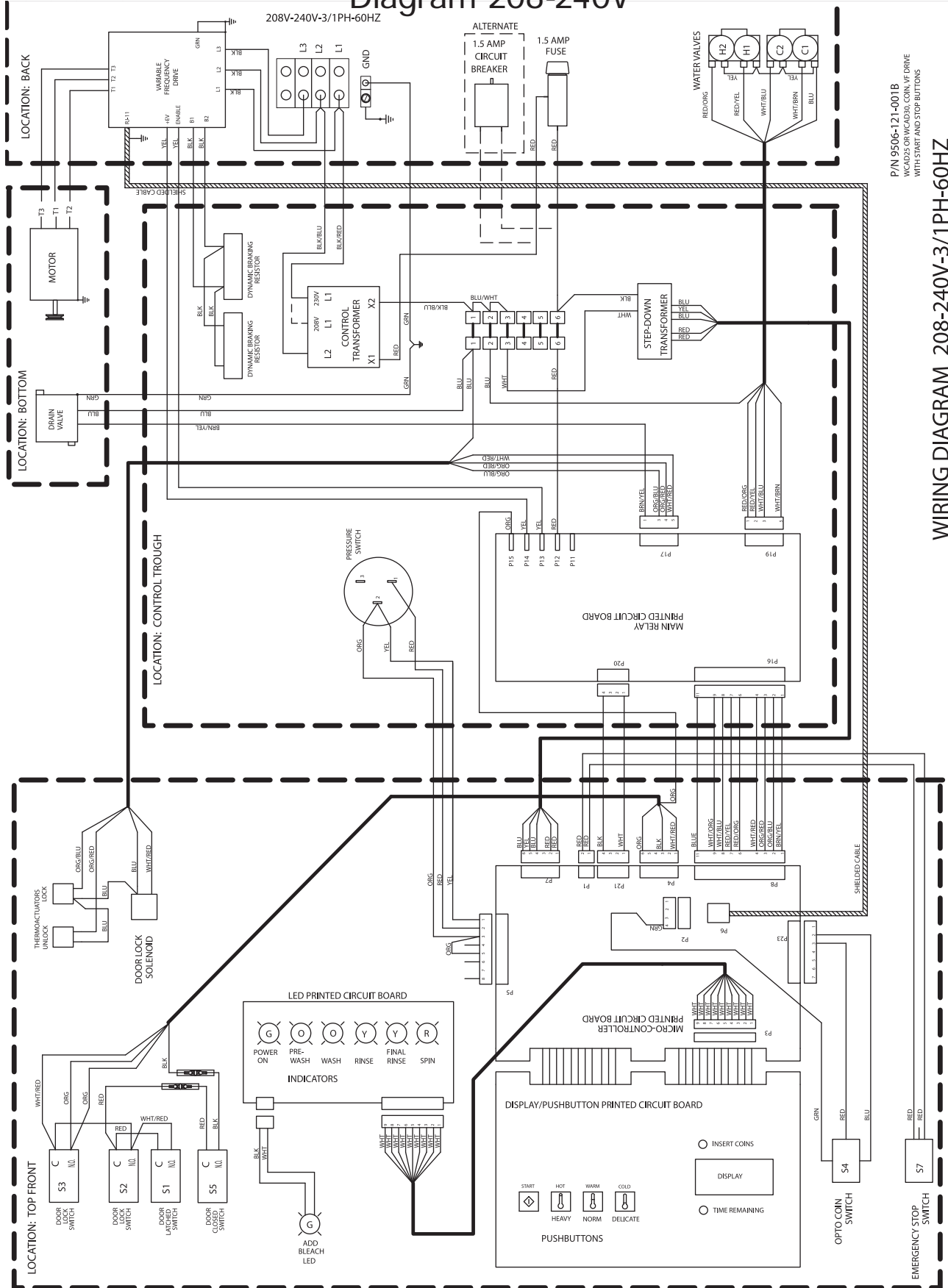

# 30Lb. Express: Non-Express Electronic Acceptor Schematic

## 208-240V

208-240V-3PH OR 1PH-60HZ

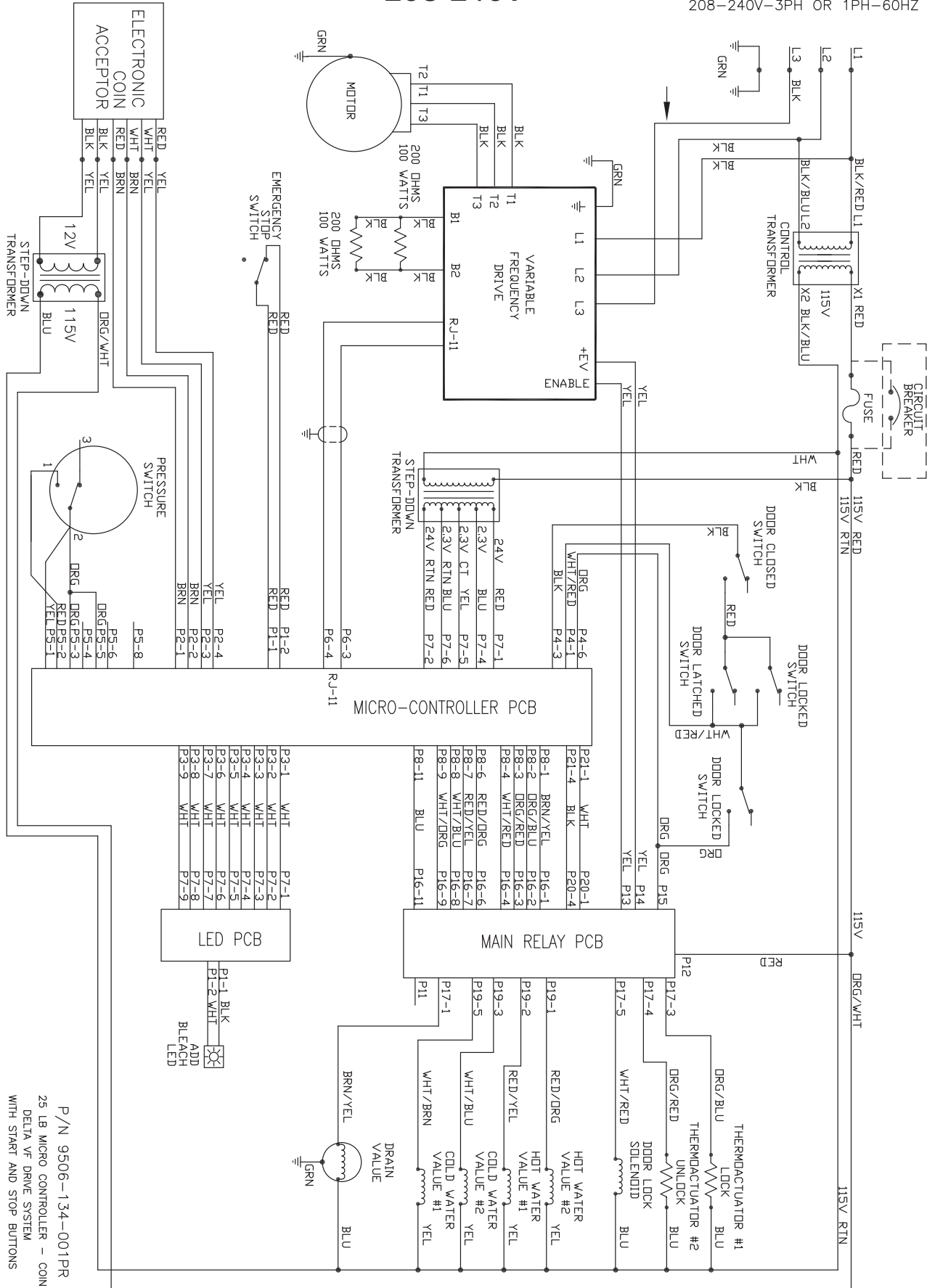

P/N 9506-134-001PR  
 25 LB MICRO CONTROLLER - CON  
 DELTA VF DRIVE SYSTEM  
 WITH START AND STOP BUTTONS

# 30Lb. Express: Non-Express Electronic Acceptor Diagram 208-240V

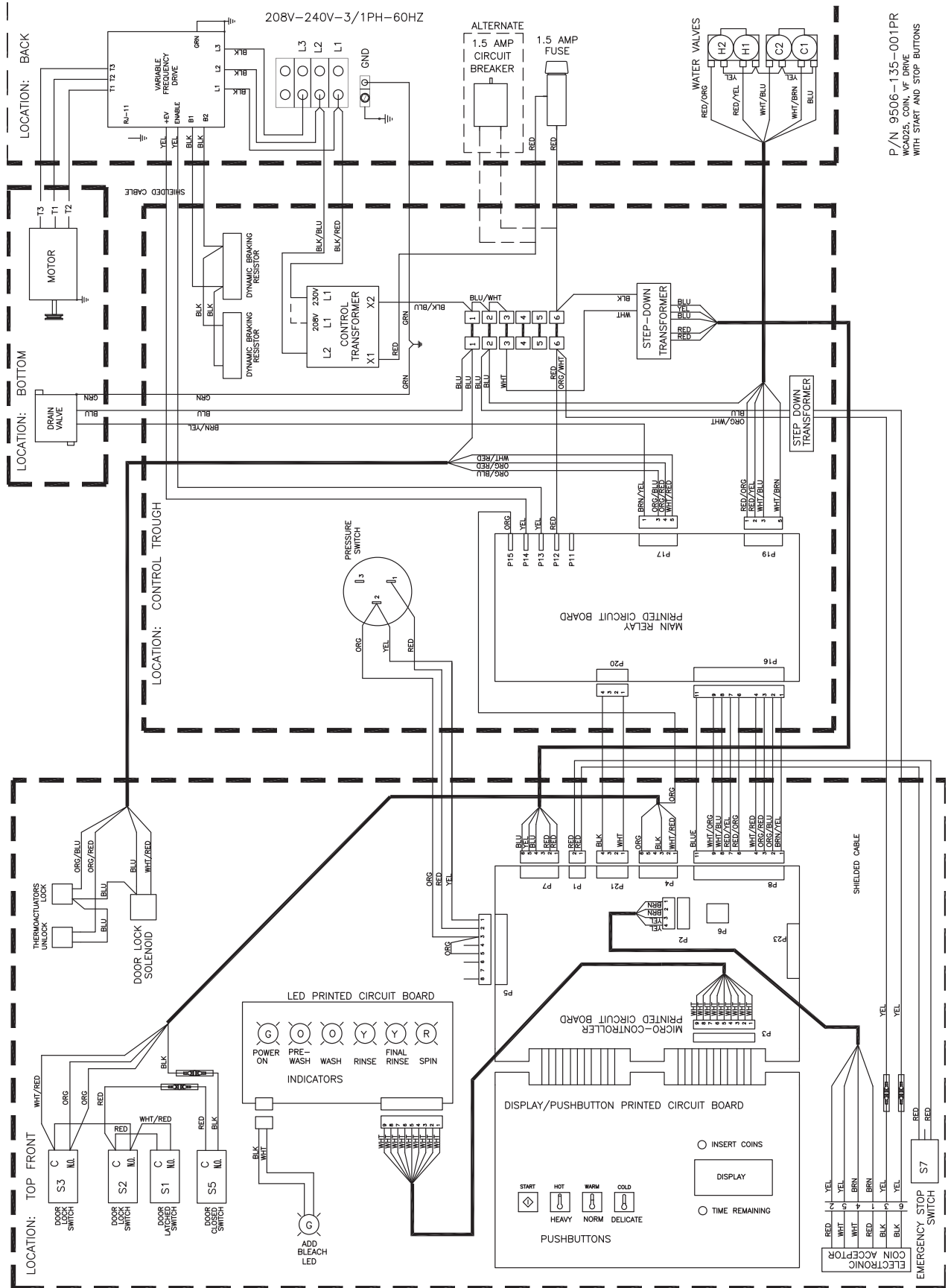

# 30Lb. Express: Non-Express: CN (No Coin Acceptor) Schematic 208-240

208-240V-3PH OR 1PH-60HZ

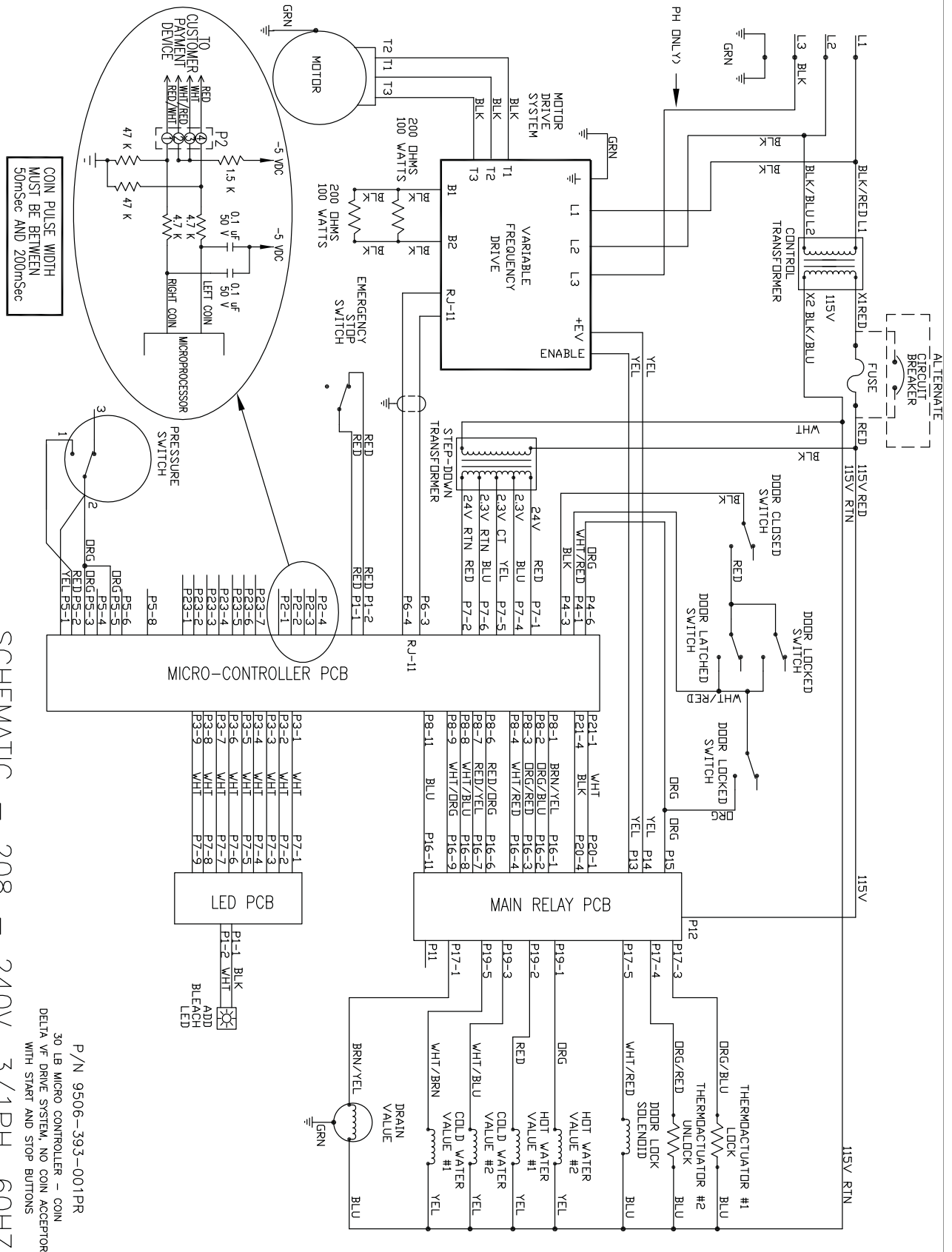



# 30Lb. Express: Non-Express: CN (No Coin Acceptor) Schematic 208-240

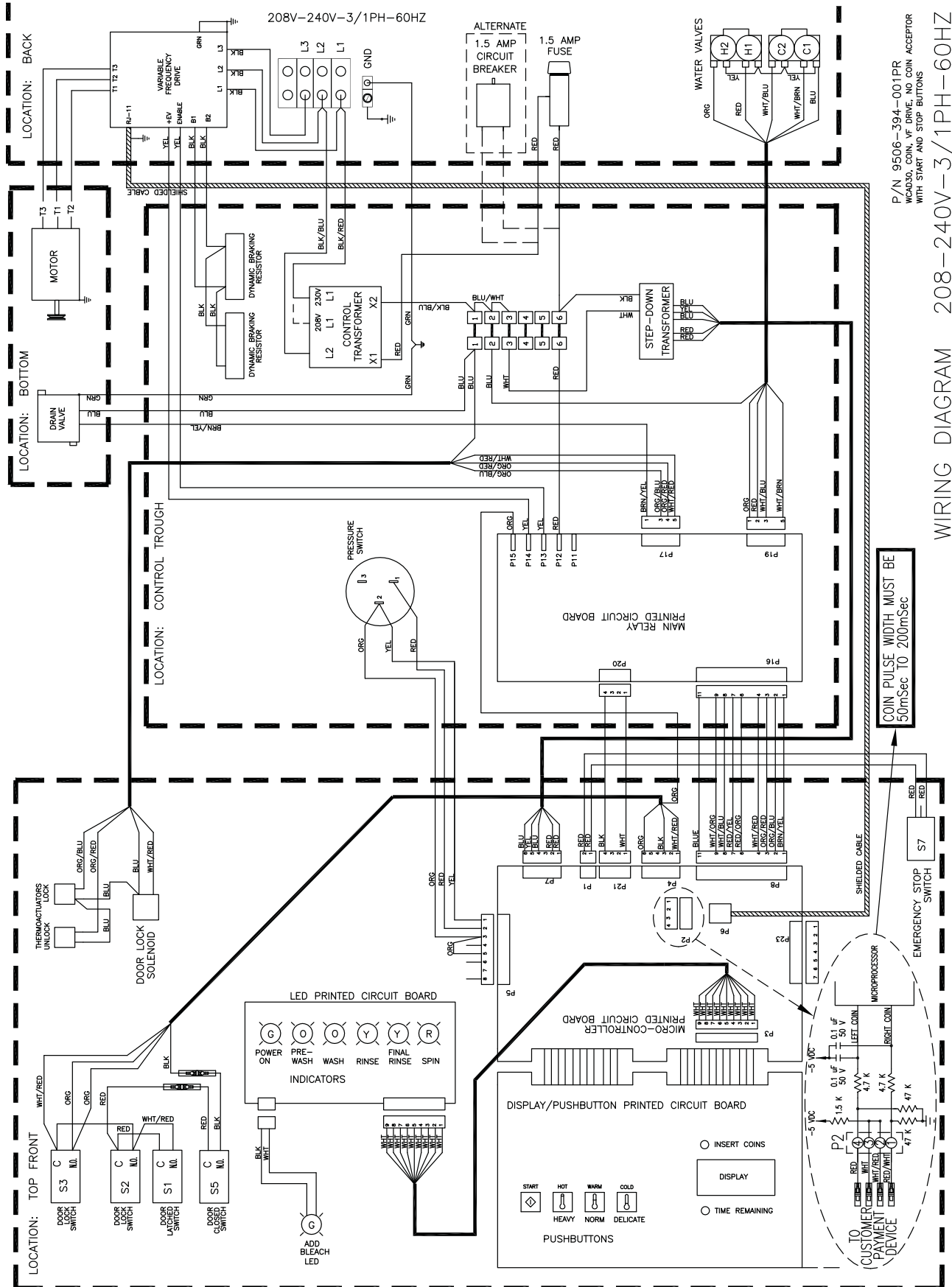

P/N 9506-394-001PR  
WASD00. COIN. VF. DRIVE. NO COIN ACCEPTOR  
WITH START AND STOP BUTTONS

WIRING DIAGRAM 208-240V-3/1PH-60HZ

COIN PULSE WIDTH MUST BE  
50mSec TO 200mSec

# 40Lb. Non-Express: Coin Micro Switch Schematic

208-240V-3PH OR 1PH-60HZ

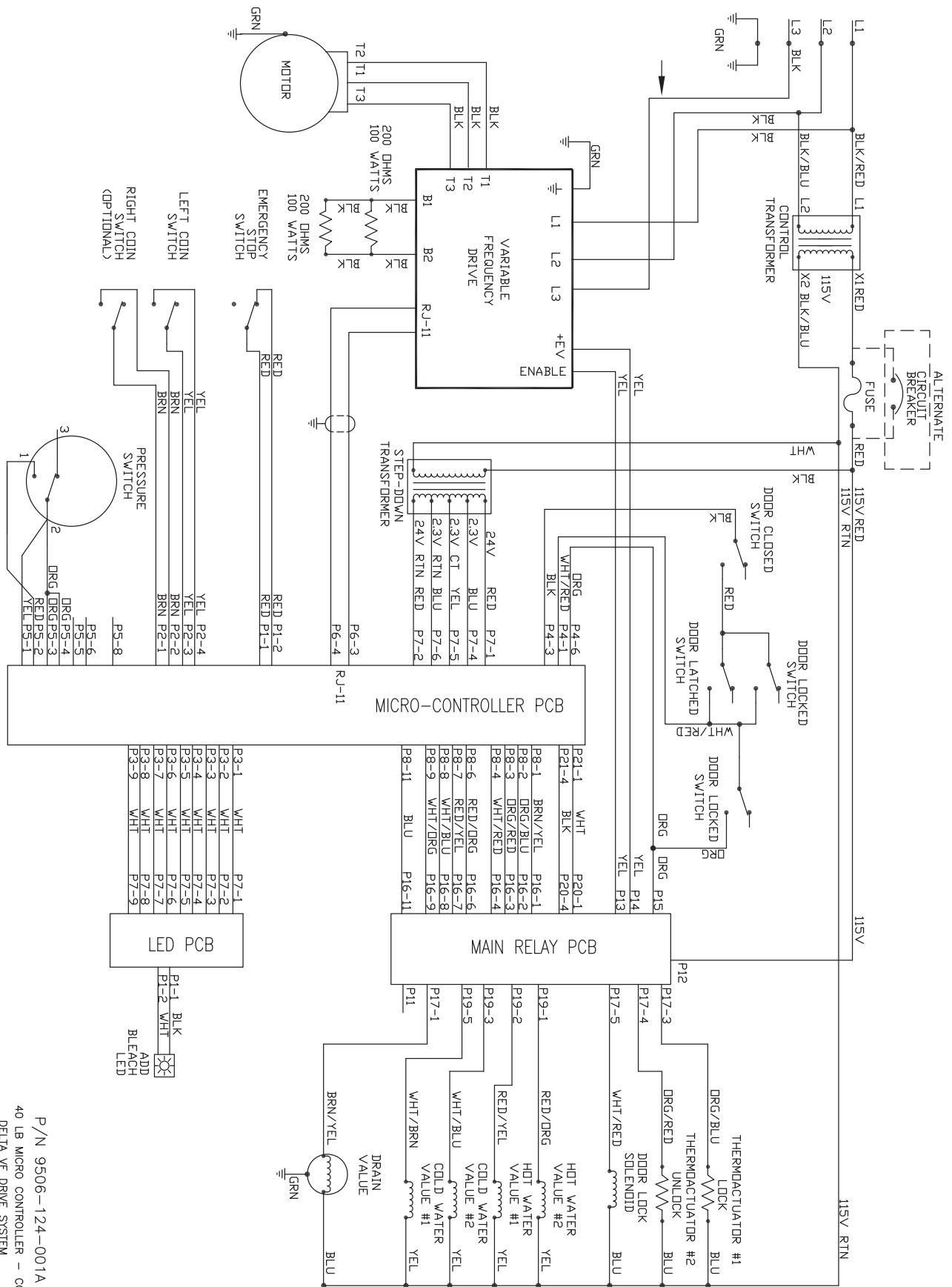

P/N 9506-124-001A  
 40 LB MICRO CONTROLLER - COIN  
 DELTA VF DRIVE SYSTEM  
 WITH START AND STOP BUTTONS

# 40Lb. Non-Express: Coin Micro Switch Diagram

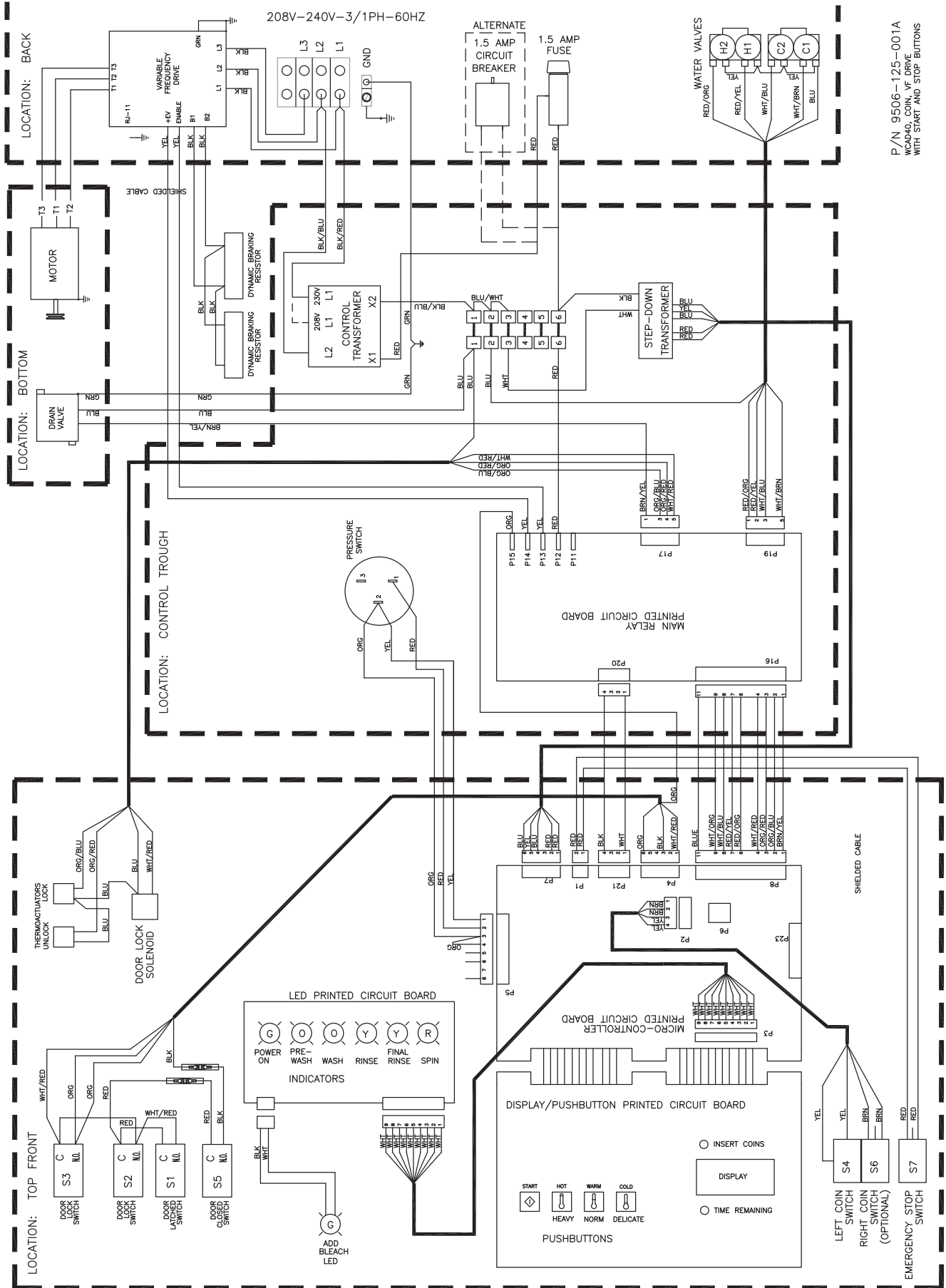

P/N 9506-125-001A  
 WC40, COIN, VF DRIVE  
 WITH START AND STOP BUTTONS



# 40lb Non-Express: U.S. Optical Acceptor Diagram 208-240V

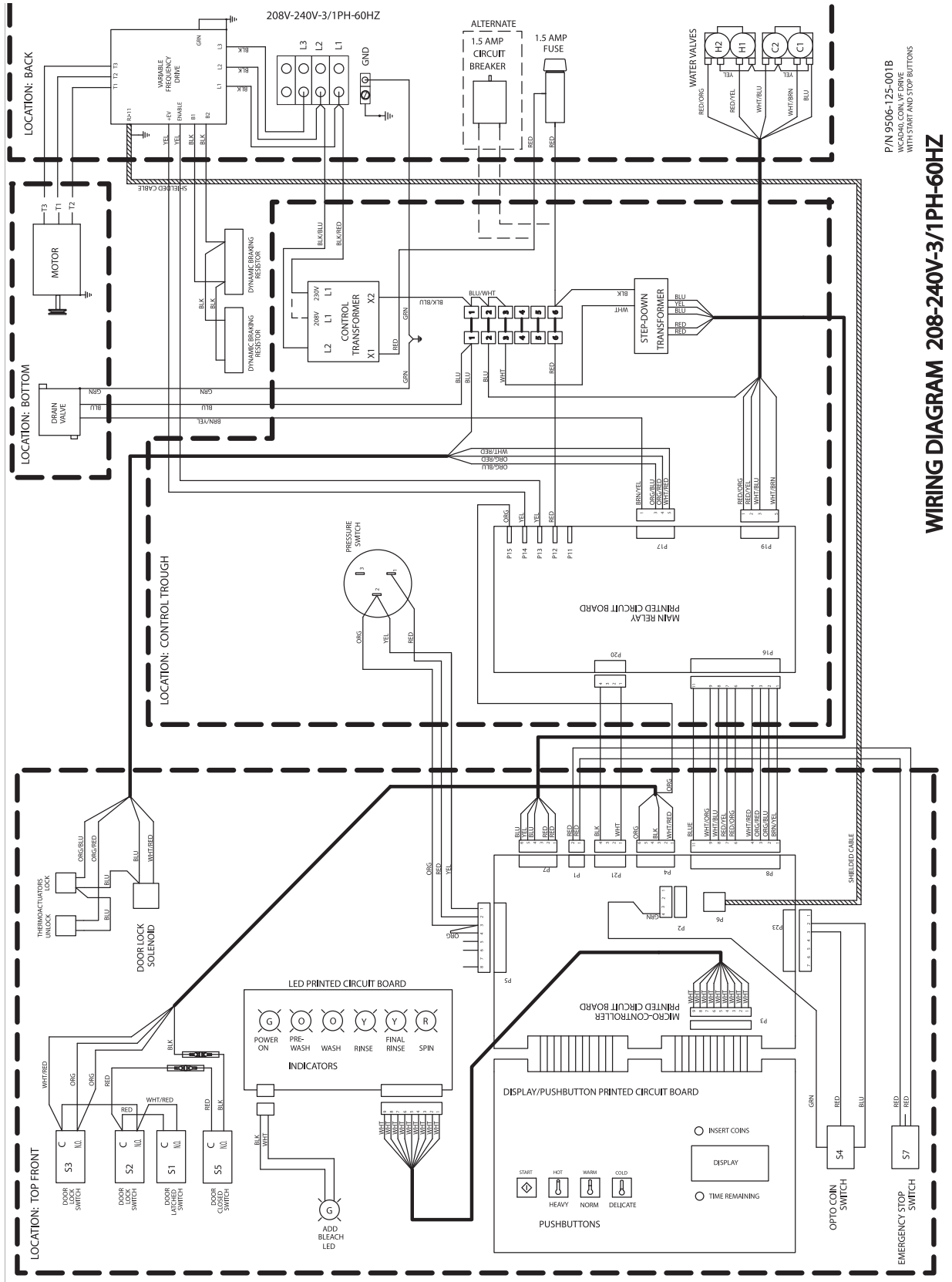

P/N 9506-125-001B  
W/COIN, COIN, V/FER/PAK  
W/15 START AND STOP BUTTONS

## WIRING DIAGRAM 208-240V-3/1PH-60HZ

# 40lb Non-Express: Electronic Acceptor Schematic 208-240V

208-240V-3PH OR 1PH-60HZ

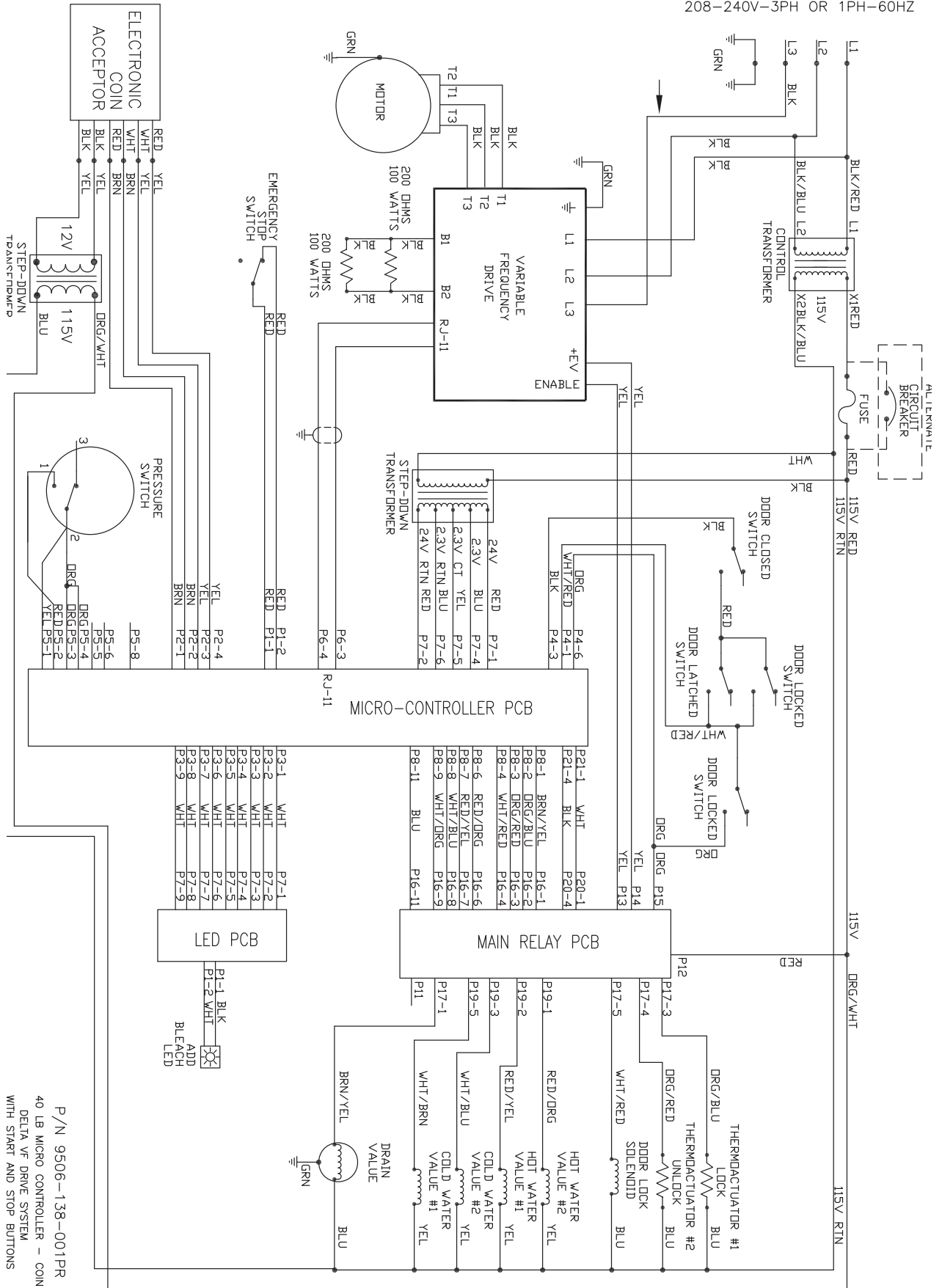

P/N 9506-138-001PR  
 40 LB MICRO CONTROLLER - COIN  
 DELTA V.F. DRIVE SYSTEM  
 WITH START AND STOP BUTTONS

# 40lb Non-Express: Electronic Acceptor Diagram 208-240V

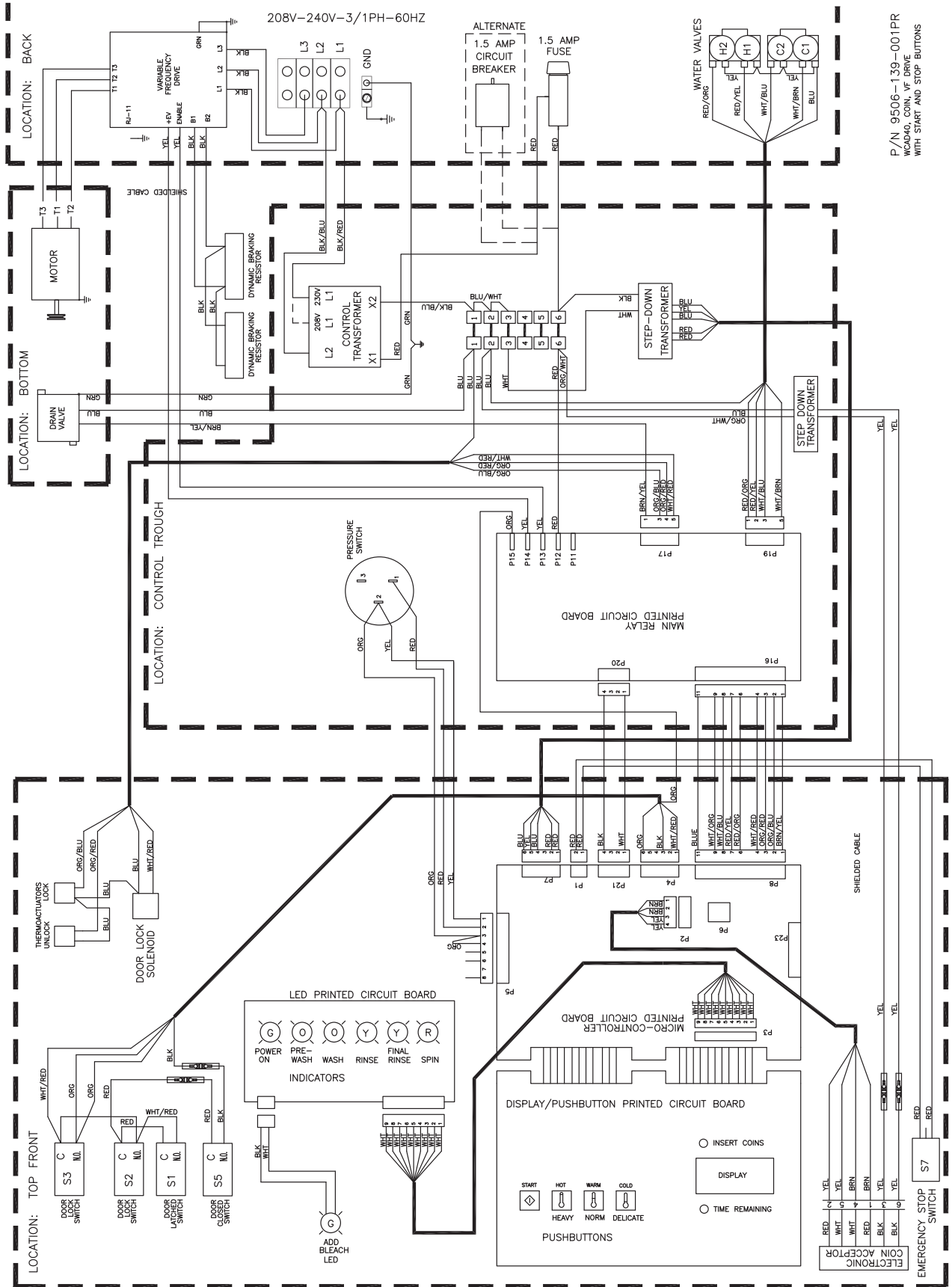

# 40Lb. Express: Non-Express: CN (No Coin Acceptor) Schematic 208-240

208-240V-3PH OR 1PH-60HZ

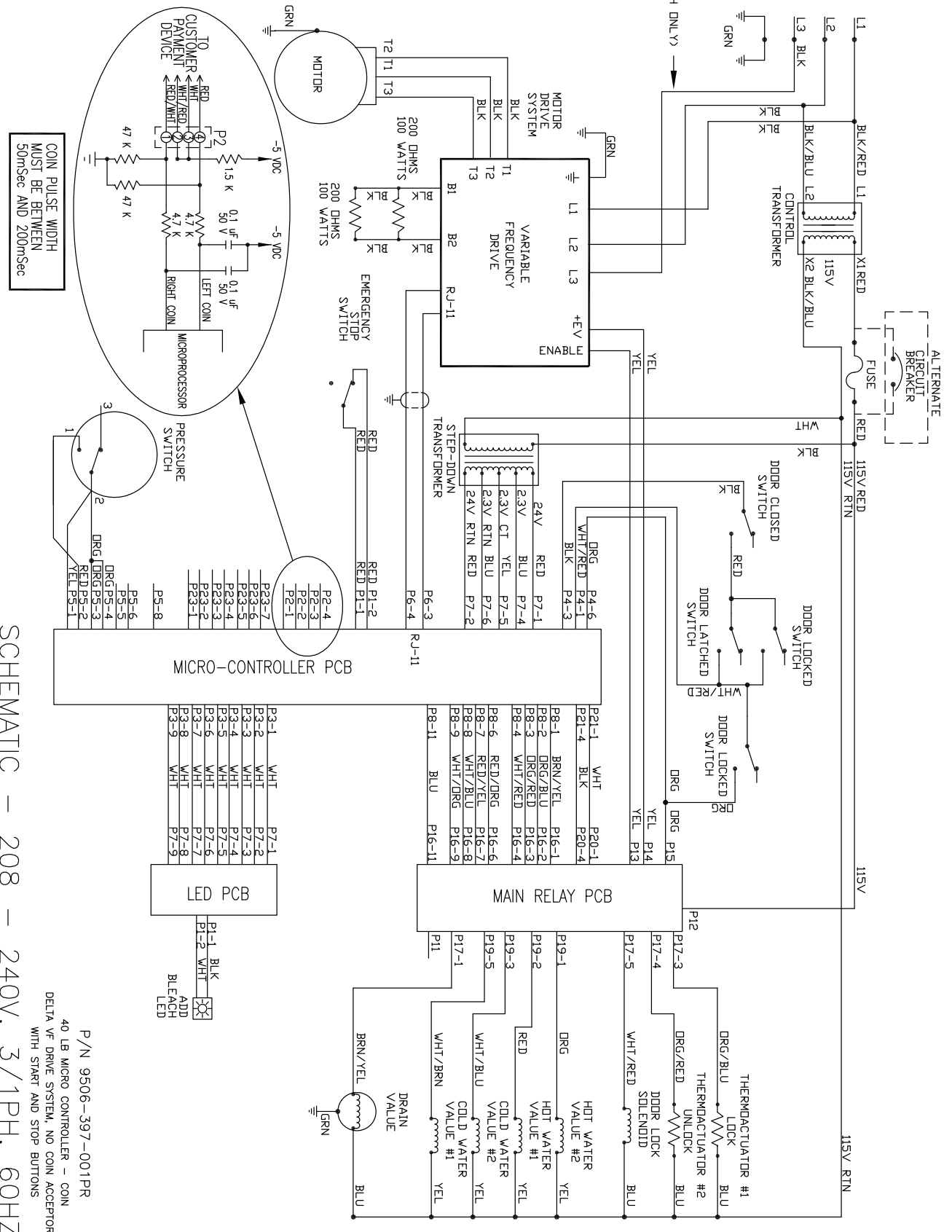



# 40Lb. Express: Non-Express: CN (No Coin Acceptor) Schematic 208-240

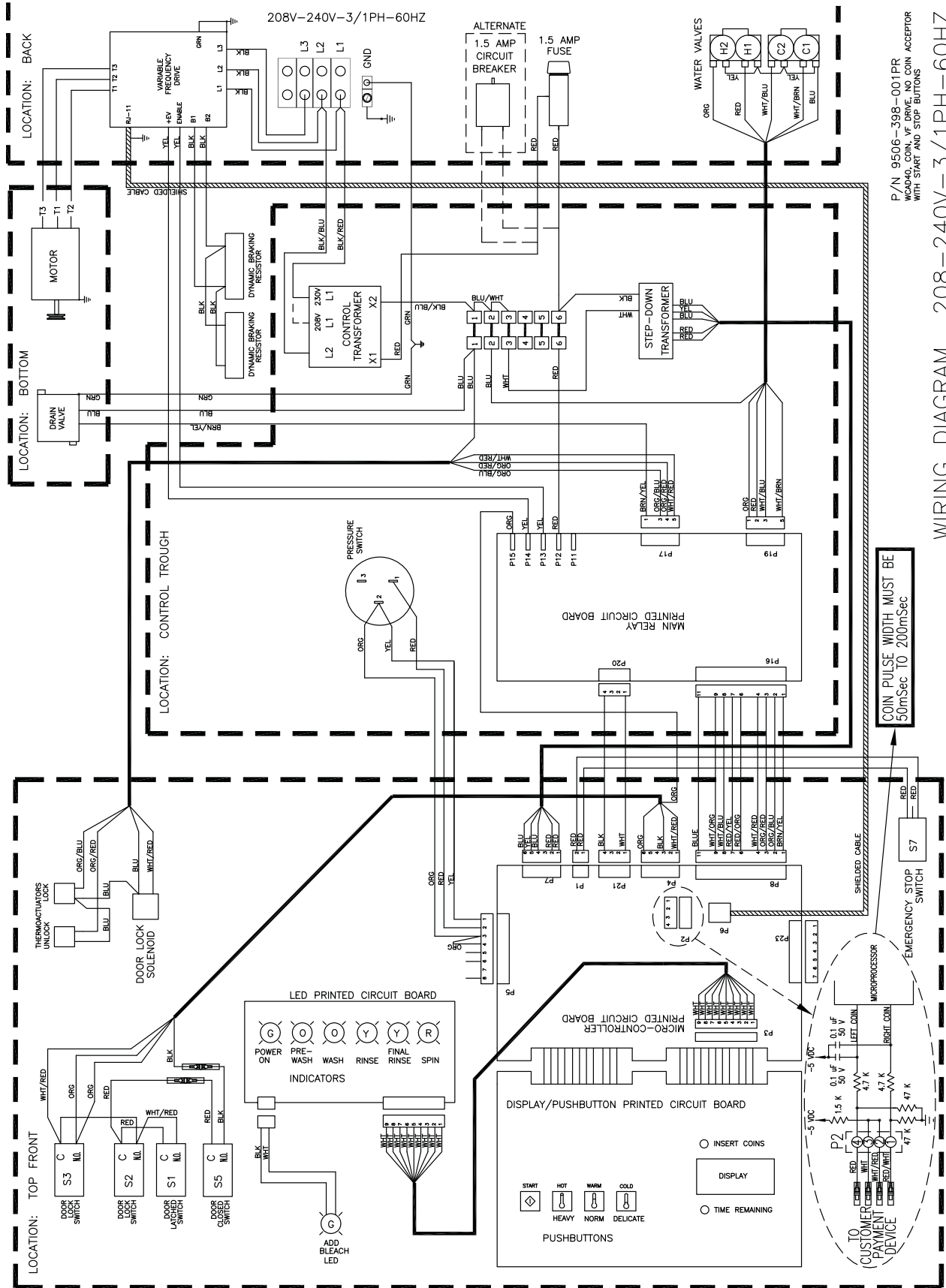



---

# Section :10

EasyCard

Interface

# Integrated Easy Card Control Panel

## Part # by Model

Key	Description	T-300	T-350	T-400	T-450	T-600	QTY
1	Panel Assembly (panel only)	9989-501-001	9989-501-001	9989-502-001	9989-502-001	9989-503-001	1
*	Screw, Hxwshrhnduct #10Bx 1/2"	9545-008-026	9545-008-026	9545-008-026	9545-008-026	9545-008-026	4
2	Front Panel	9454-781-002	9454-781-002	9454-659-002	9454-659-002	9454-669-002	1
*	Post Locator Top	9467-024-001	9467-024-001	9467-024-001	9467-024-001	9467-024-001	2
*	Nut Hexkeps #6-32	8640-411-003	8640-411-003	8640-411-003	8640-411-003	8640-411-003	2
*	Locator Panel	9355-001-001	9355-001-001	9355-001-001	9355-001-001	9355-001-001	2
*	Screw FillHDCR 10Bx1/2"	9545-008-023	9545-008-023	9545-008-023	9545-008-023	9545-008-023	2
*	Spacer Pushbutton (Micro)	9538-178-001	9538-178-001	9538-178-001	9538-178-001	9538-178-001	1
*	Retainer Pushbutton (Micro)	9486-150-001	9486-150-001	9486-150-001	9486-150-001	9486-150-001	1
*	Nut Hexelasticstop #6-32	8640-411-003	8640-411-003	8640-411-003	8640-411-003	8640-411-003	2
5	Pushbutton Control (coin)	9035-060-003	9035-060-003	9035-060-003	9035-060-003	9035-060-003	1
6	PCB assembly Control /Display STOP	9473-009-002	9473-009-002	9473-009-002	9473-009-002	9473-009-002	1
*	Spacer Plastic #6x9/16	9538-157-018	9538-157-018	9538-157-018	9538-157-018	9538-157-018	5
*	Nut Elasticstop #6-32	8640-411-002	8640-411-002	8640-411-002	8640-411-002	8640-411-002	5
*	Harness LEDPCB	9627-797-001	9627-797-001	9627-797-001	9627-797-001	9627-797-001	1
4	Harness Doorlock	9627-791-003	9627-791-003	9627-791-003	9627-791-003	9627-791-004	1
7	PCB assembly Mode lights	9473-005-001	9473-005-001	9473-005-001	9473-005-001	9473-005-001	1
*	Spacer Plastic #6x9/16	9538-157-018	9538-157-018	9538-157-018	9538-157-018	9538-157-018	2
*	Nut Hexkeps #6-32	8640-411-003	8640-411-003	8640-411-003	8640-411-003	8640-411-003	2
8	Light, LED,ADD BLEACH As-sembly	9794-001-001	9794-001-001	9794-001-001	9794-001-001	9794-001-001	1
*	Spacer Plastic #6x9/16	9538-157-018	9538-157-018	9538-157-018	9538-157-018	9538-157-018	2
*	Nut Hexeps #6-32	8640-411-003	8640-411-003	8640-411-003	8640-411-003	8640-411-003	2
9	Nameplate,Control Panel (one piece)	9412-144-001	9412-158-001	9412-146-001	9412-146-001	9412-148-001	1
10	Switch Assembly Emergency Stop	9732-223-001	9732-223-001	9732-223-001	9732-223-001	9732-223-001	1
11	Solenoid Ass'y, Door Locking (see Door Lock Group for parts breakdown)	9922-011-001	9922-011-001	9922-011-001	9922-011-001	9922-011-001	1
16	Hex Nuts (mounting solenoid assy. to control panel)	8640-412-005	8640-412-005	8640-412-005	8640-412-005	8640-412-005	3
12	Battery	8612-001-001	8612-001-001	8612-001-001	8612-001-001	8612-001-001	1
13	Harness V-reader ALL MODELS	9627-827-001	9627-827-001	9627-827-001	9627-827-001	9627-827-001	1
14	Card Reader Assembly Complete	9797-007-003	9797-007-003	9797-007-003	9797-007-003	9797-007-003	1
15	Cable Assembly 4 twisted pair 12' shld/unshld reader to rear of machine	9806-013-002	9806-013-002	9806-013-002	9806-013-002	9806-013-002	1
*	Mounting plate for card reader	9982-337-001	9982-337-001	9982-337-001	9982-337-001	9982-337-001	1

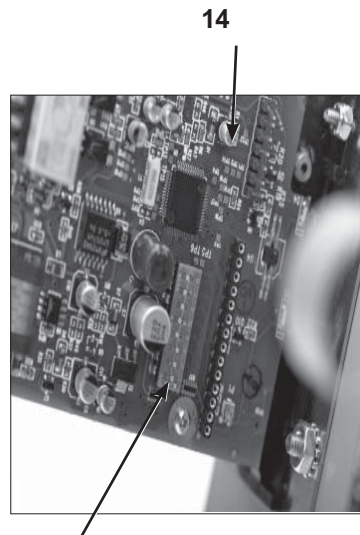
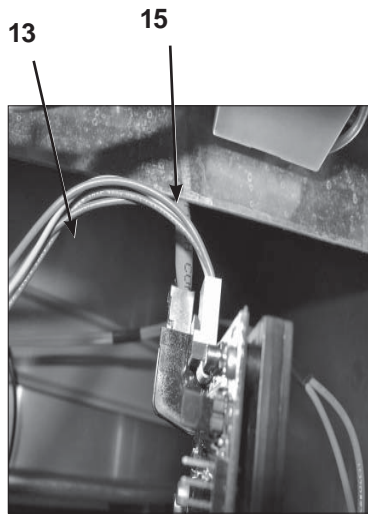

**Reader Wire  
Harness  
Connection**

**Address Switch**

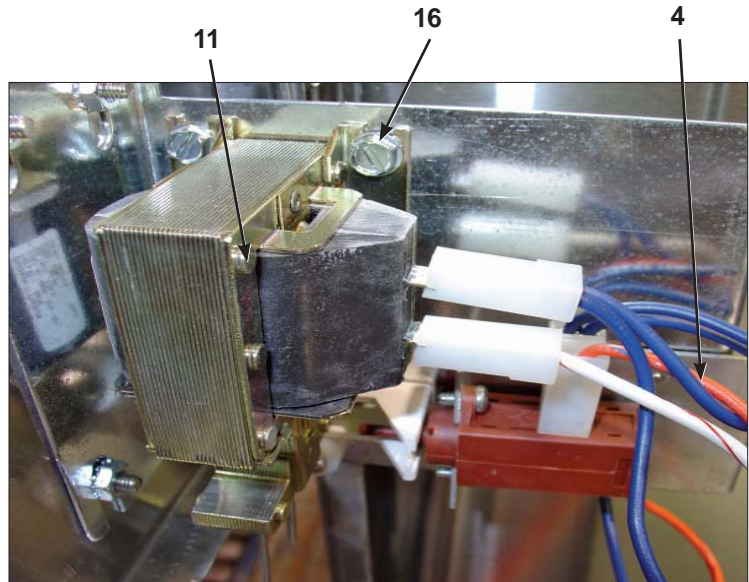
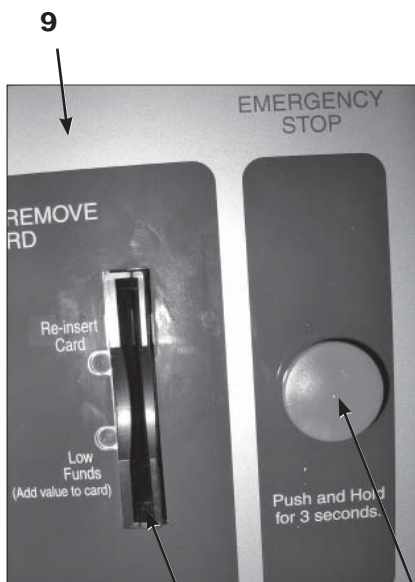
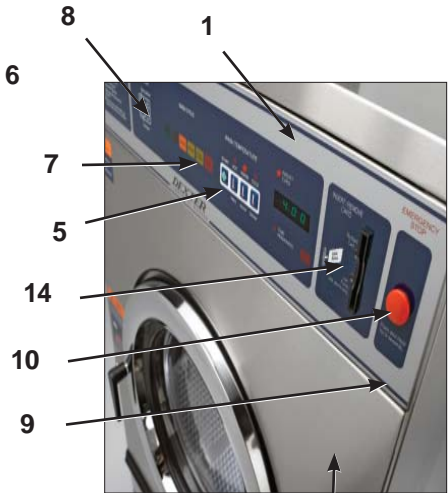
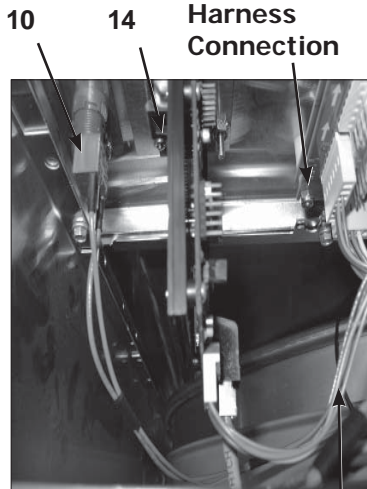

14

10

# IEC Double Load 20Lb. Non-Express: 120 Volt Wiring Schematic

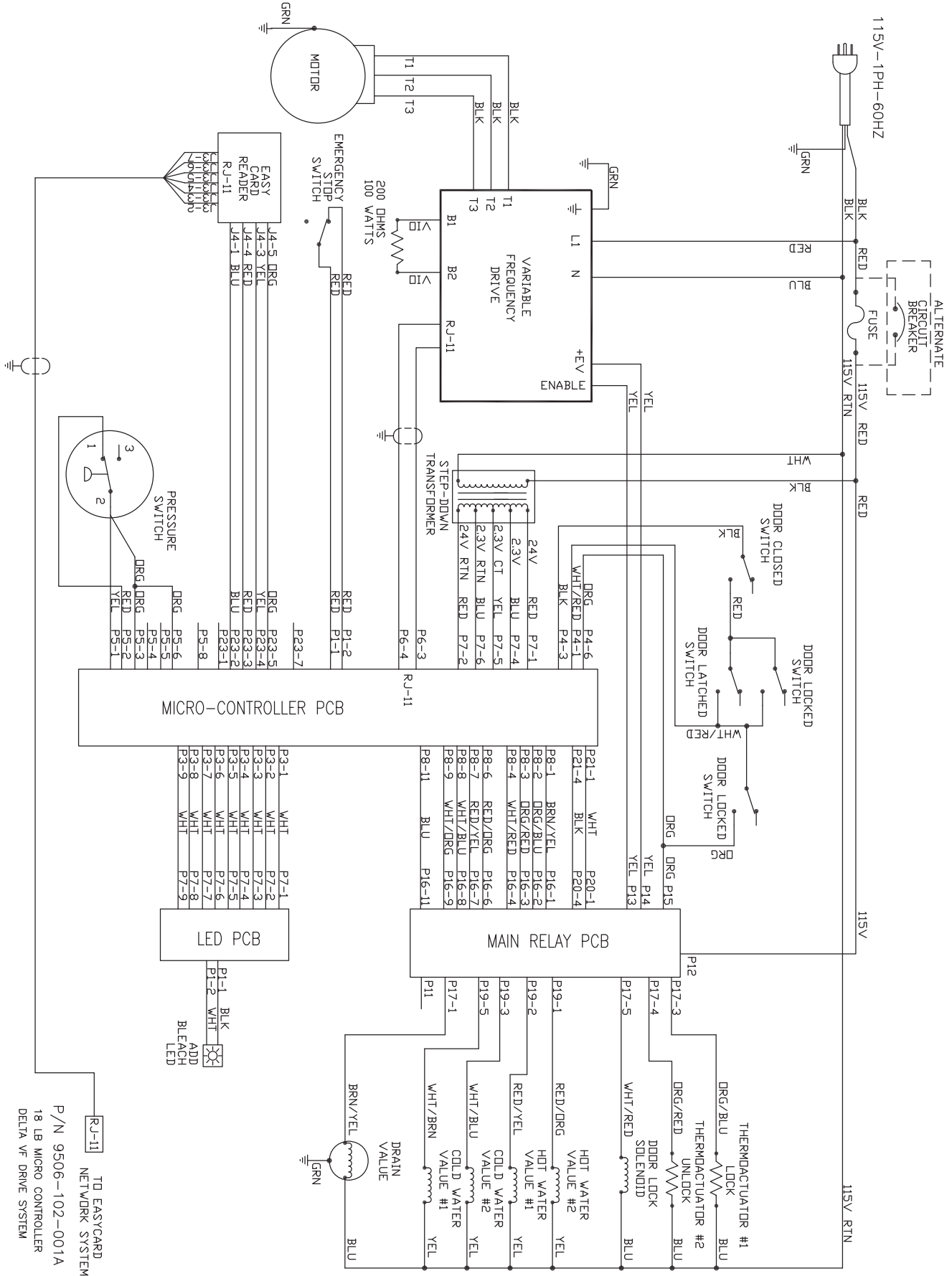

# IEC Double Load 20Lb. Non-Express: 120 Volt Wiring Diagram

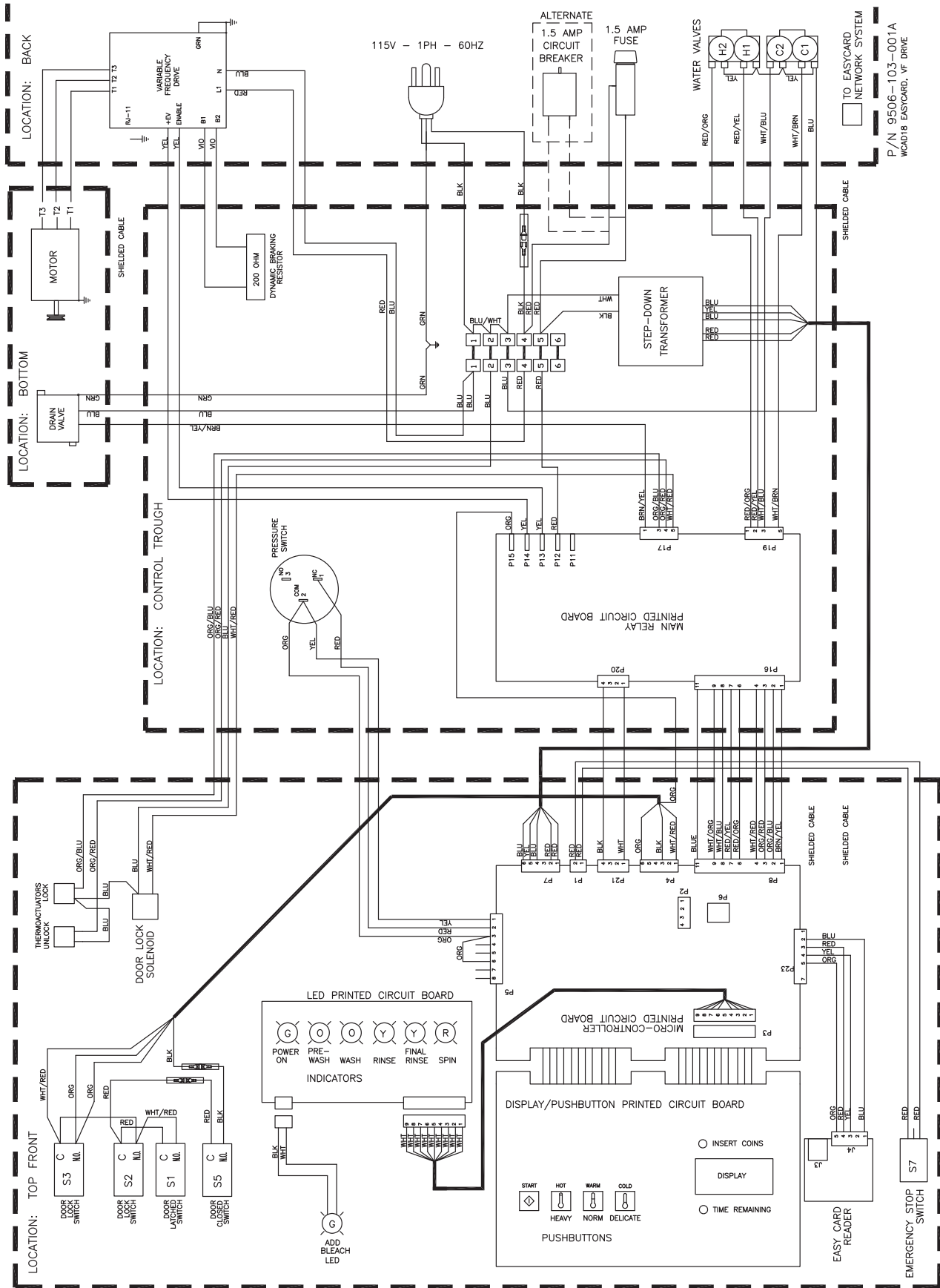

# IEC 20Lb. Non-Express: 208-240 Volt Wiring Schematic

208-240V-3PH OR 1PH-60HZ

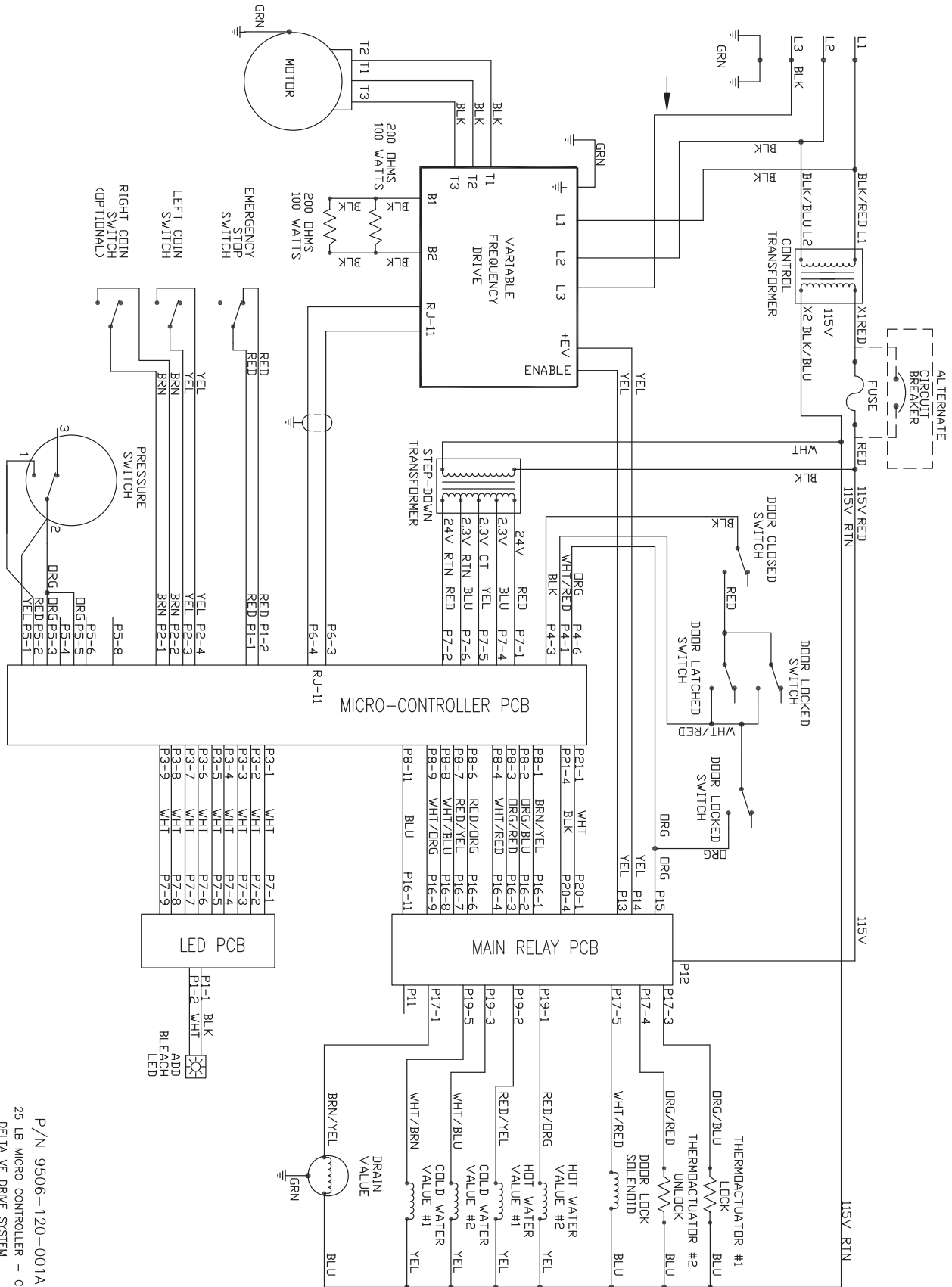

P/N 9506-120-001A  
25 LB MICRO CONTROLLER - COIN  
DELTA VF DRIVE SYSTEM  
WITH START AND STOP BUTTONS



# IEC 20Lb. Non-Express: 208-240 Volt Wiring Diagram

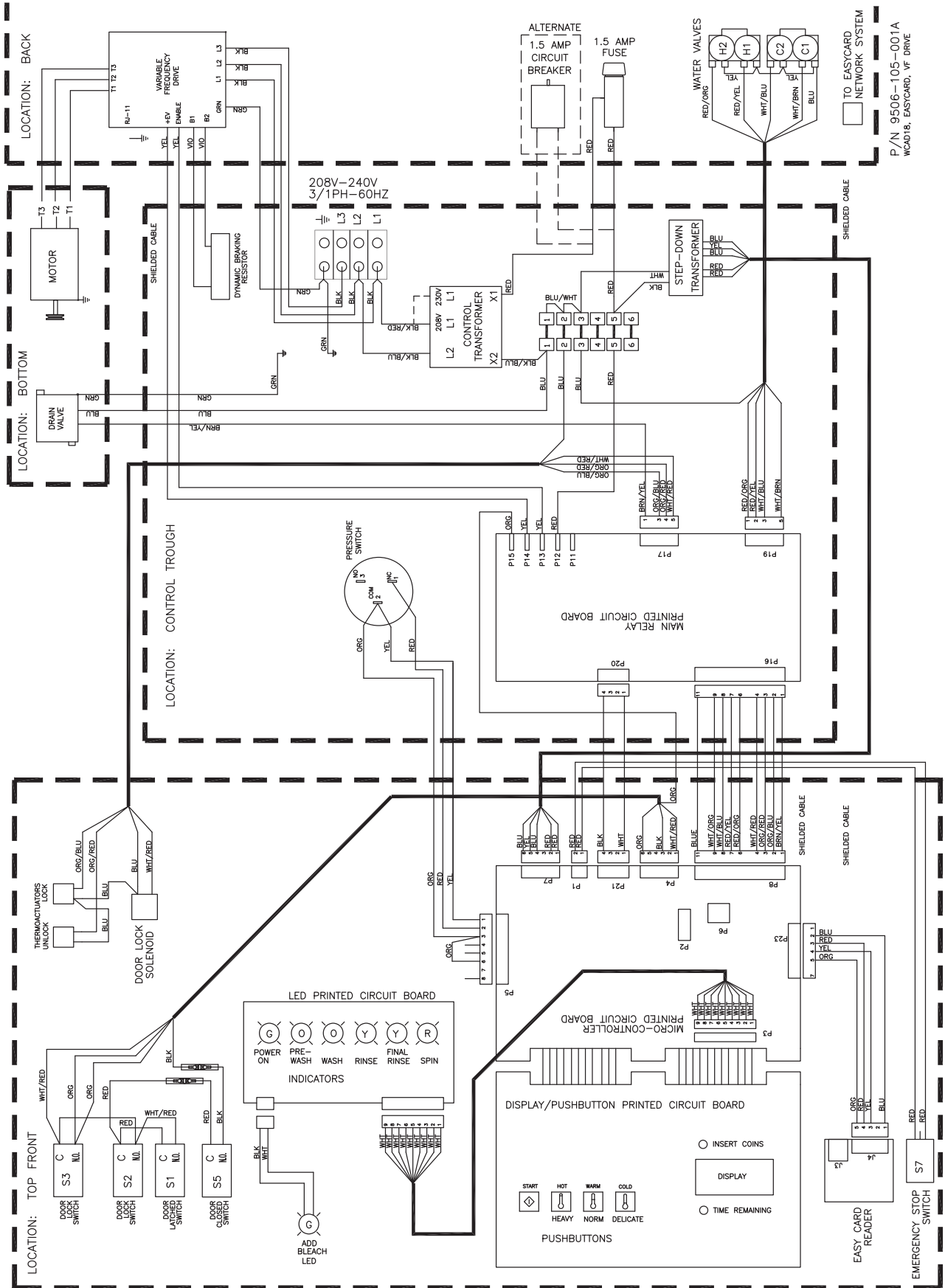

P/N 9506-105-001A  
WCA018, EASYCARD, VF DRIVE

# IEC 20Lb. Express: 208-240 Volt Wiring Schematic

208-240V-3PH OR 1PH-60HZ

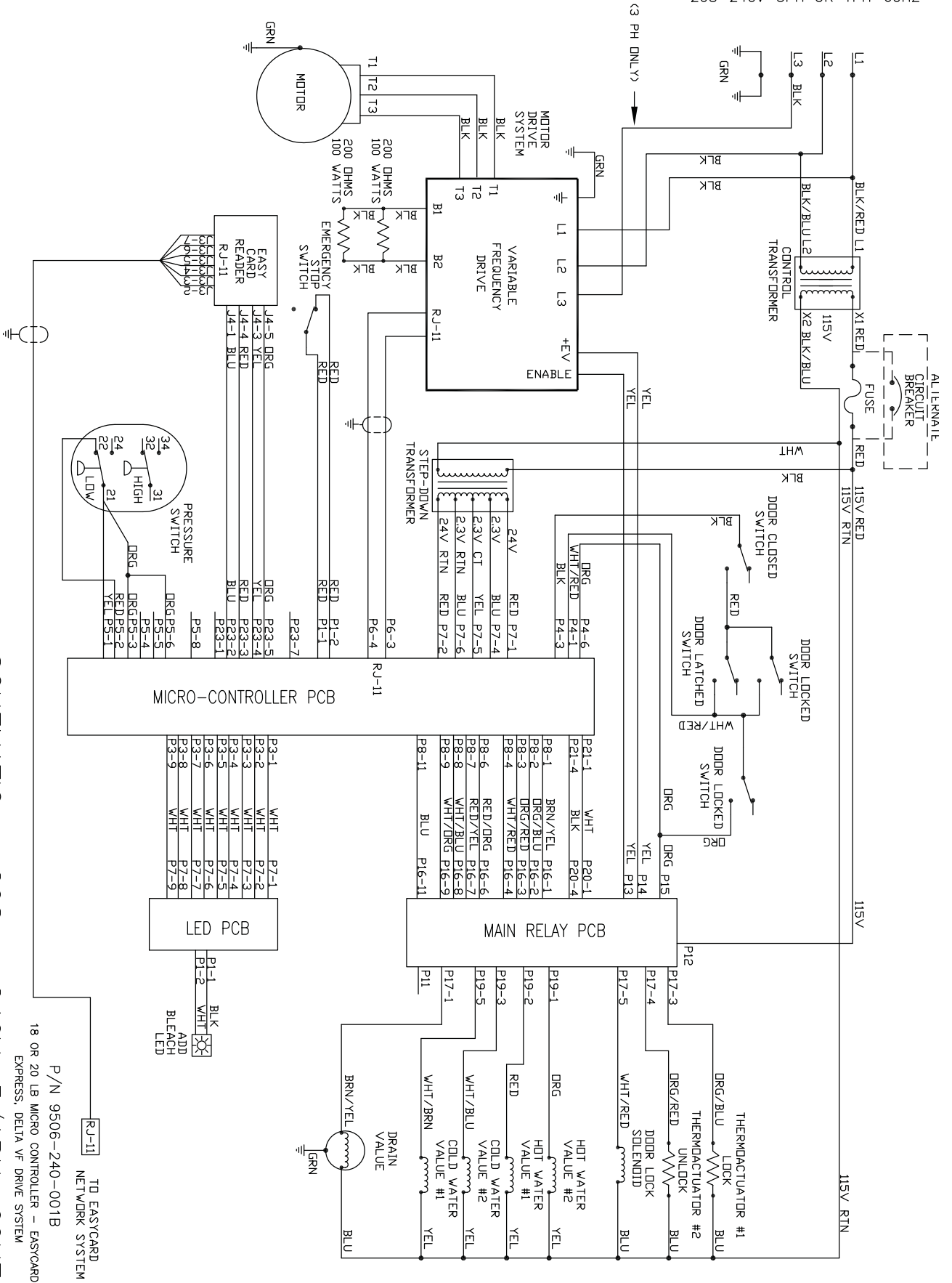

SCHEMATIC -- 208 -- 240V, 3/1PH, 60HZ

P/N 9506-240-001B  
18 OR 20 LB MICRO CONTROLLER - EASYCARD  
EXPRESS, DELTA V/F DRIVE SYSTEM  
RJ-11 TD EASYCARD NETWORK SYSTEM

# IEC 20Lb. Express: 208-240 Volt Wiring Schematic

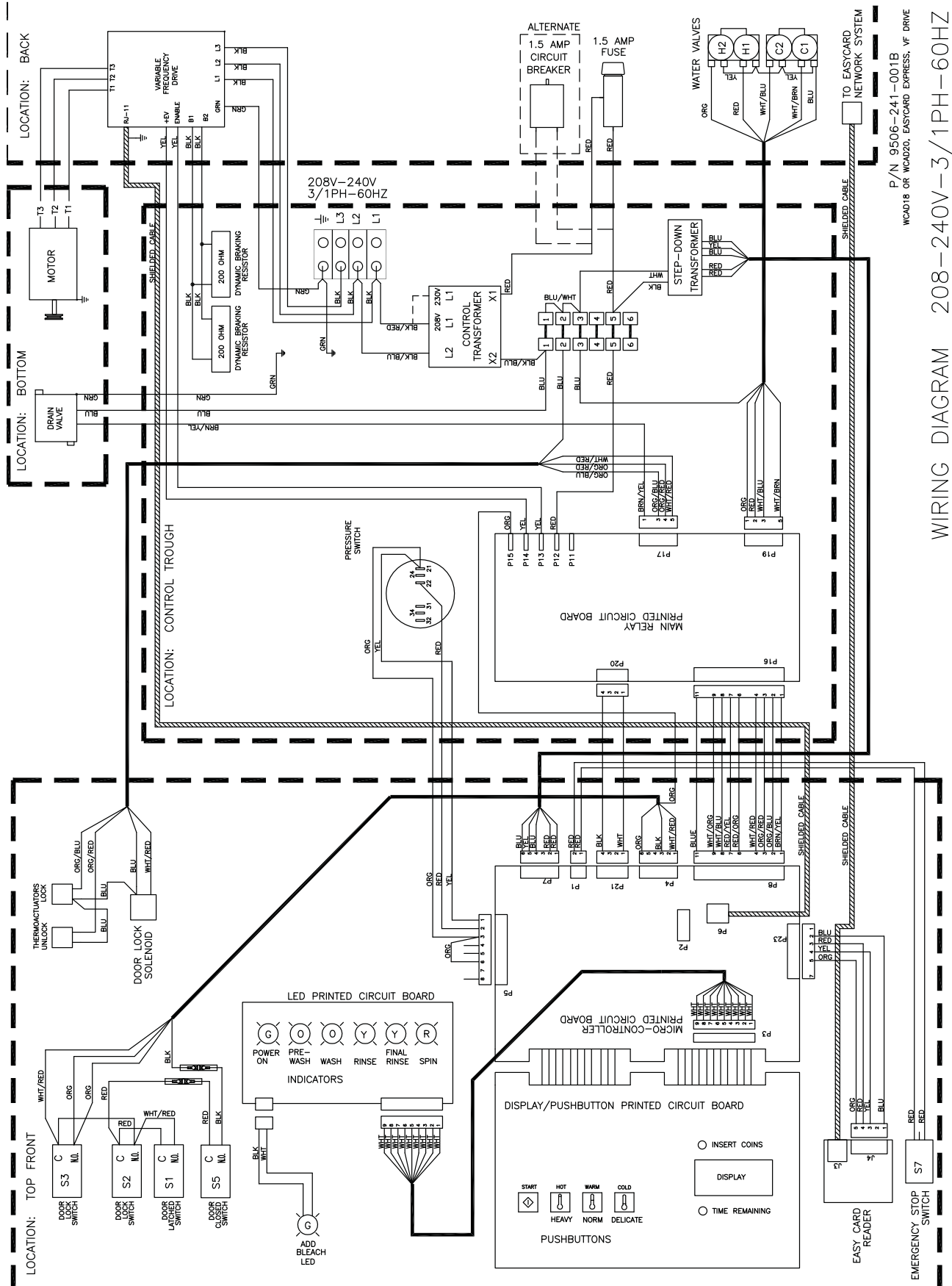

WIRING DIAGRAM 208-240V-3/1PH-60HZ  
 P/N 9506-241-001B  
 WCA018 OR WCA020, EASTCARD EXPRESS, VF DRIVE  
 TO EASYCARD NETWORK SYSTEM

# IEC 30Lb. Non-Express & Express: Schematic

208-240V-3PH OR 1PH-60HZ

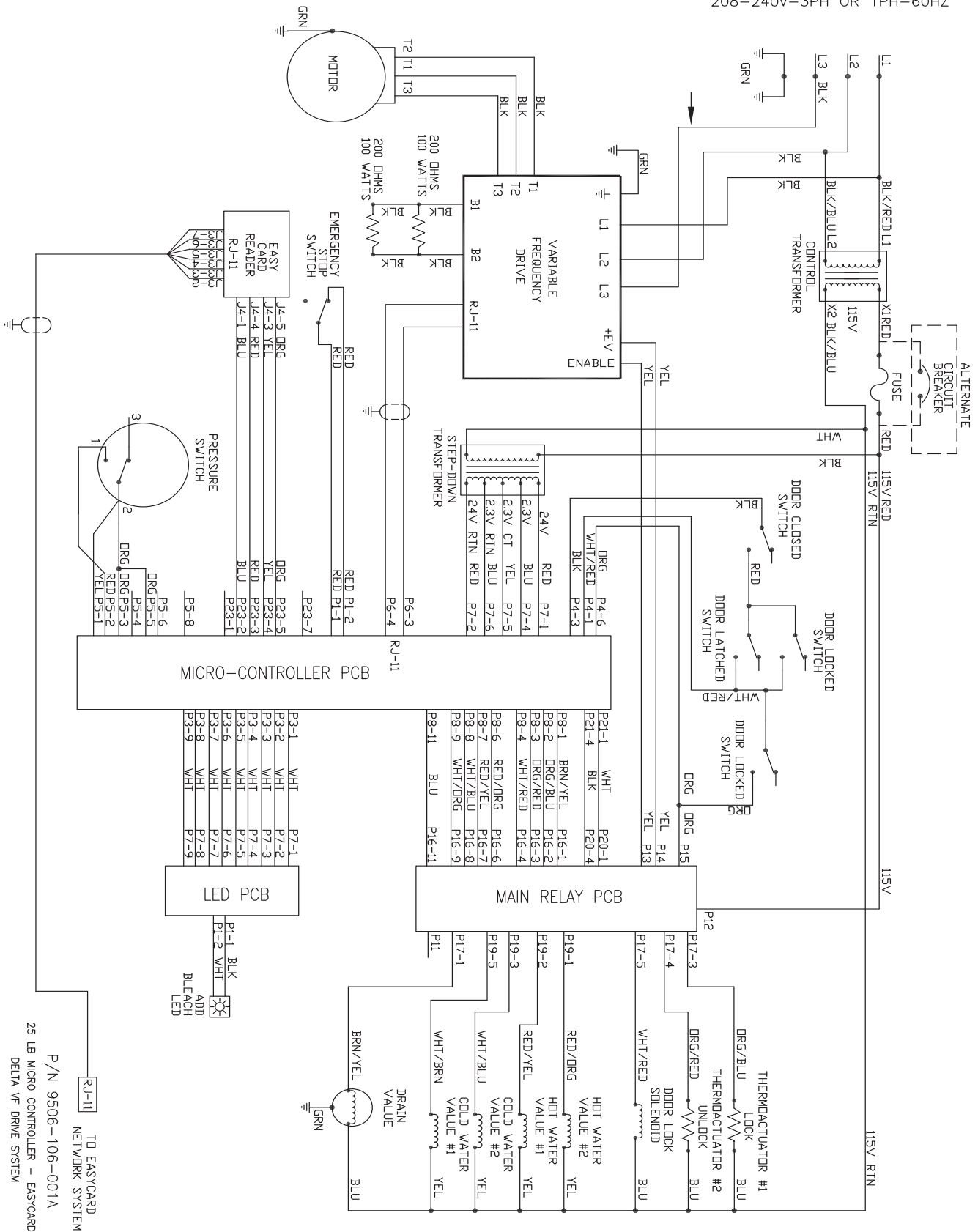

# IEC 30Lb. Non-Express & Express: Diagram

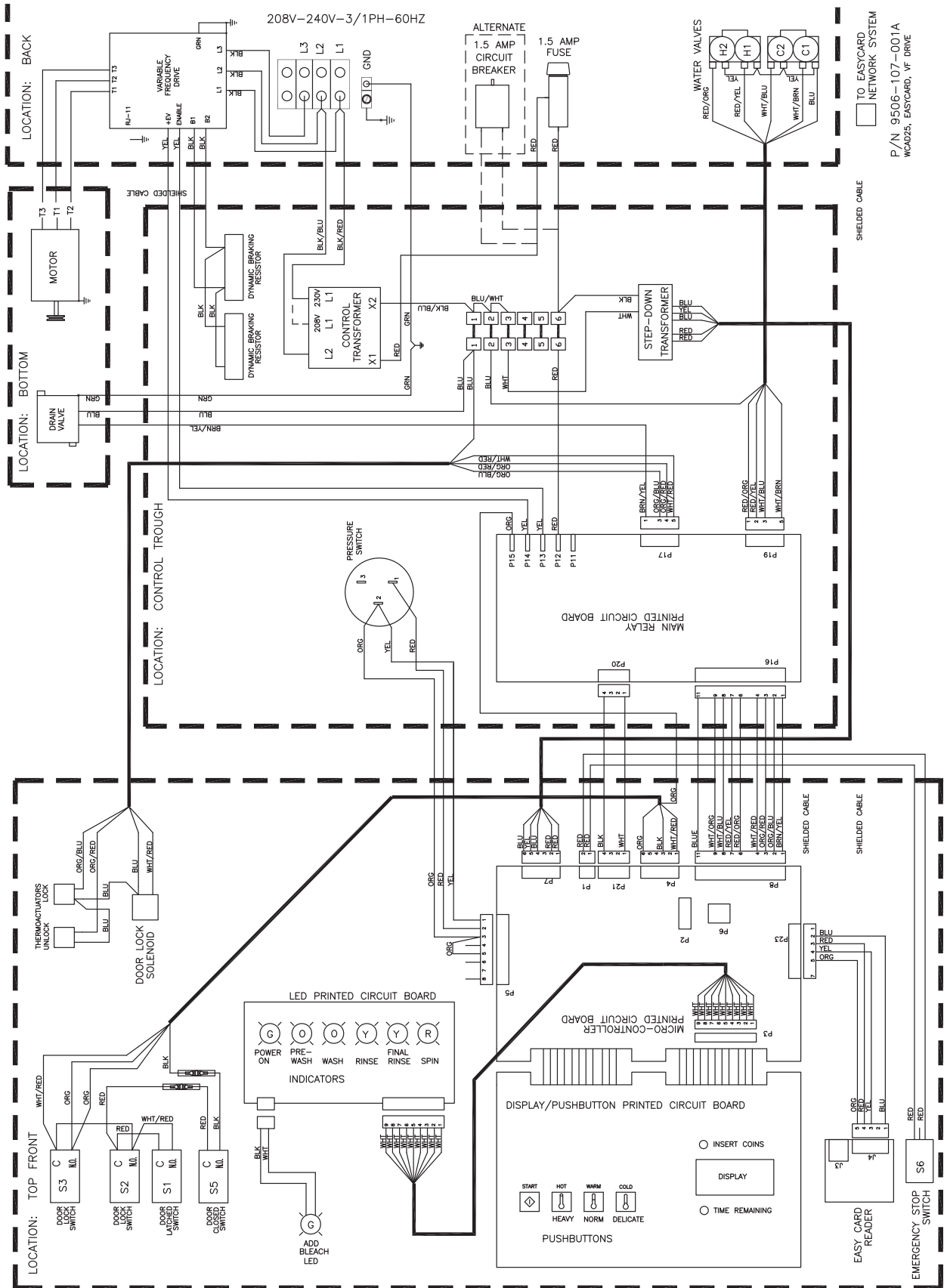

P/N 9506-107-001A  
WC025, EASTCARD, V6 DRIVE

# IEC Maxi Load 40Lb. Non-Express: Wiring Schematic

208-240V-3PH OR 1PH-60HZ

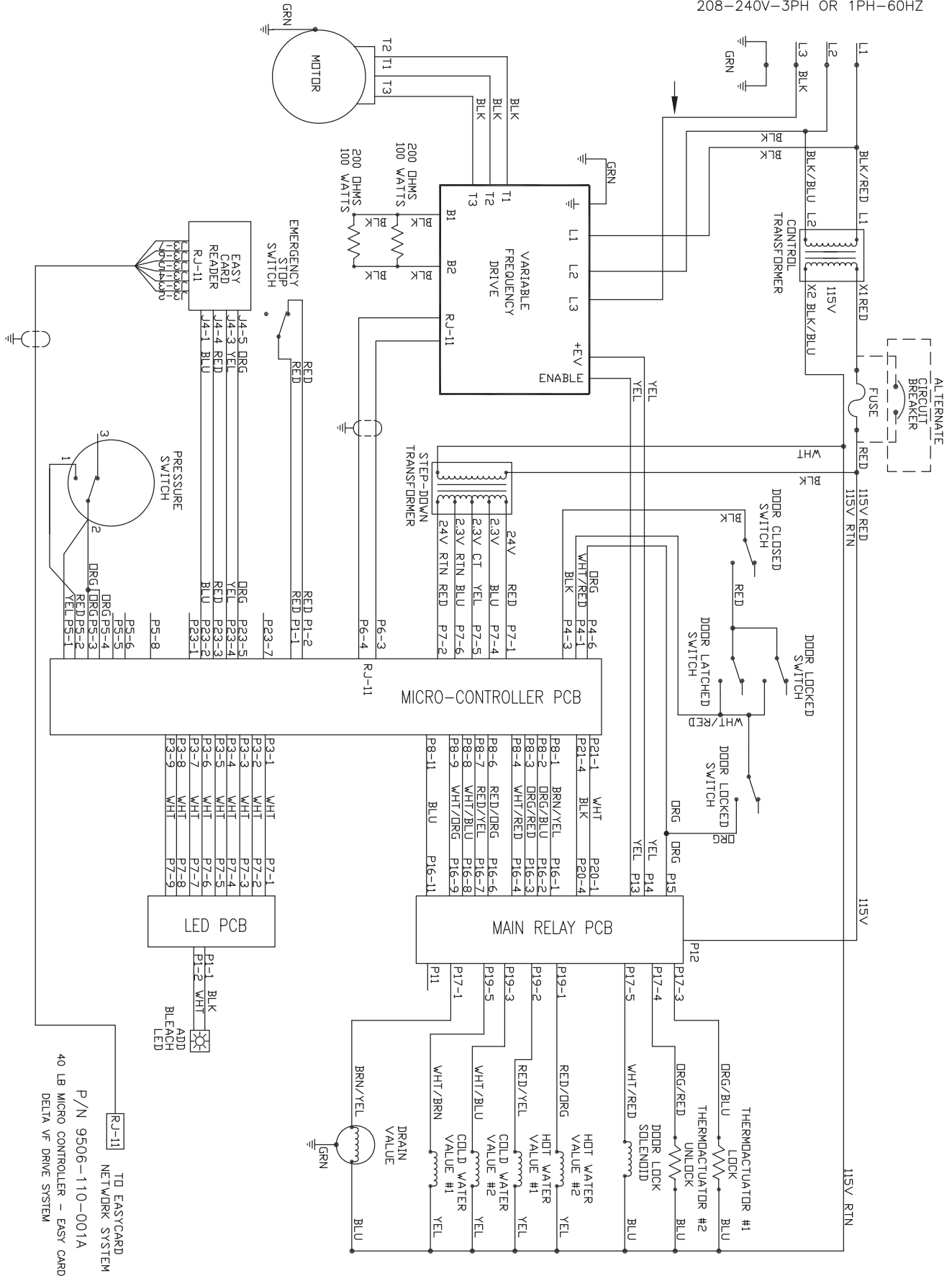

RJ-11 TO EASYCARD NETWORK SYSTEM  
P/N 9506-110-001A  
40 LB MICRO CONTROLLER - EASY CARD  
DELTA VF DRIVE SYSTEM

# IEC Maxi Load 40Lb. Non-Express: Wiring Diagram

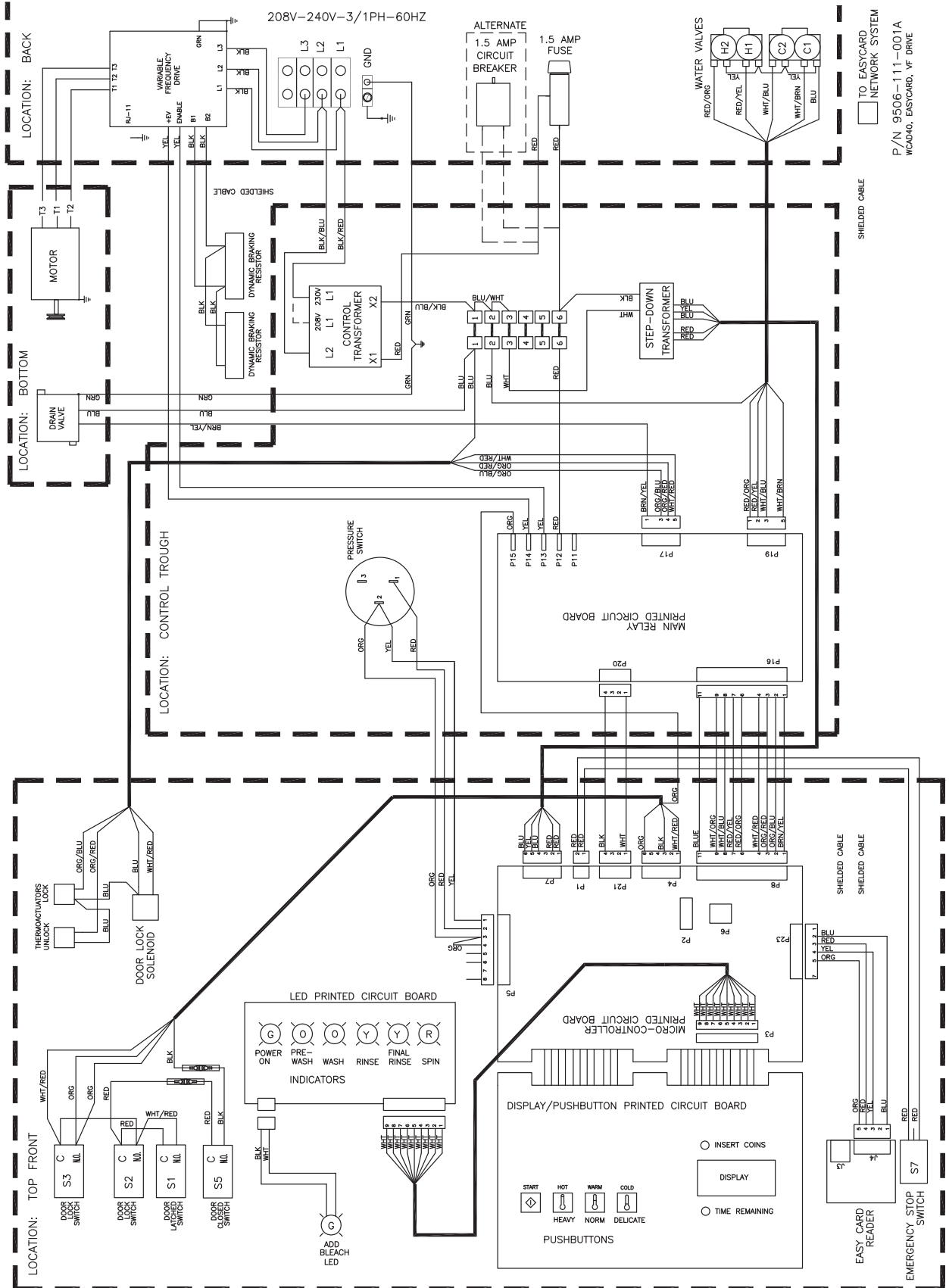

---

# Notes

A series of horizontal lines for taking notes.



---

# Section :11

## Parts 50Hz

### Models:

Parts in this section used only in these models. All other parts are same as standard 60 Hz pages.

Wiring Diagrams & Schematics

## Transformer, Electrical Filter and Coin Handling -59 models

Key	Component	WCAD20KCS-59	WCAD20KCS-59SZ	WCAD30KCS-59	WCAD30KCS-59SZ	WCAD40KCS-59	QTY
1	Circuit Breaker	5198-211-002	5198-211-002	5198-211-002	5198-211-002	5198-211-002	1
*	Wire Assembly Black / Red	8220-001-232	8220-001-232	8220-061-003	8220-061-003	8220-061-003	1
*	Wire Assembly Black / Blue	8220-001-233	8220-001-233	8220-061-004	8220-061-004	8220-061-004	1
*	Wire Assembly Red	8220-001-282	8220-001-282	8220-001-282	8220-001-282	8220-001-282	1
*	Wire Assembly Black / Blue	8220-065-007	8220-065-007	8220-065-007	8220-065-007	8220-065-007	1
*	Wire Assembly Red	8220-065-011	8220-065-011	8220-065-011	8220-065-011	8220-065-030	1
*	Instructions, Transformer Connect	8507-230-003	8507-230-003	8507-230-003	8507-230-003	8507-230-003	1
*	Owners Booklet	8514-168-001	8514-170-001	8514-176-001	8514-178-001	8514-124-001	1
*	Nut #8-32	8640-412-005	8640-412-005	8640-412-005	8640-412-005	8640-412-005	13
*	Nut #10-32	8640-413-002	8640-413-002	8640-413-002	8640-413-002	8640-413-002	28
*	Lockwasher - Exttooth #6	8641-582-005	8641-582-005	8641-582-005	8641-582-005	8641-582-005	2
2	Controls Transformer	8711-008-002	8711-008-002	8711-008-002	8711-008-002	8711-008-002	1
3	Transformer	8711-009-003	8711-009-003	8711-009-003	8711-009-003	8711-009-003	1
4	Coin Acceptor - Electronic	9021-011-001	9021-011-001	9021-011-001	9021-011-001	9021-011-001	1
5	Harness - Electronic Coin Acceptor	9627-845-001	9627-845-001	9627-845-001	9627-845-001	9627-845-001	1
*	Bracket Terminal/Filter Mounting	9029-188-001	9029-177-001	9029-170-001	9029-170-001	9029-170-001	1
*	Standoff, Twistloc	9527-002-002	9527-002-002	9527-002-002	9527-002-002	9527-002-002	6
*	Rear Channel 18lb OPL	9081-132-002	9081-132-002				1
6	EMI Line Filter	9183-030-003	9183-030-004	9183-031-002	9183-031-002	9183-031-002	1
7	EMI Filter 1 ph, 20 Amp	9183-040-001	9183-040-001	9183-040-001	9183-040-001	9183-040-001	1

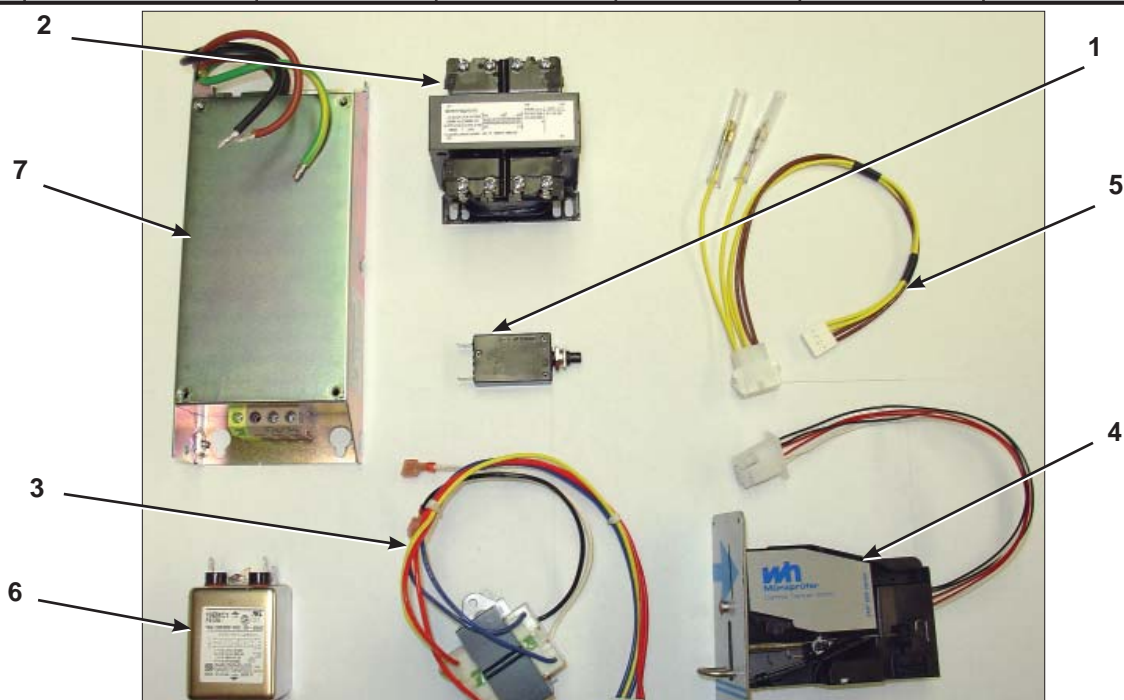

# Water Valve, Drain Valve and Door Locking -59 models

Key	Component	WCAD20KCS-59	WCAD20KCS-59SZ	WCAD30KCS-59	WCAD30KCS-59SZ	WCAD40KCS-59	QTY
1	Water Valve	9379-183-007	9379-183-007	9379-183-007	9379-183-007	9379-183-007	2
2	Drain Valve 2" inch	9379-177-011	9379-177-011				1
3	Drain Valve 3" inch			9379-187-003	9379-187-003	9379-187-003	1
*	Filter Mounting Plate	9452-758-001	9452-758-001	9452-747-001	9452-747-001	9452-747-001	1
*	Wiring Label , Schematic	9506-407-001	9506-411-001	9506-415-001	9506-419-001	9506-425-001	1
*	Wiring Label , Diagram	9506-408-001	9506-412-001	9506-416-001	9506-420-001	9506-426-001	1
5	Solenoid, Door Lock	9536-082-001	9536-082-001	9536-082-001	9536-082-001	9536-082-001	1
*	Screw #10B - 32 X 1/2	9545-008-026	9545-008-026				52
*	Screw #10-32 TT X1/2	9545-008-027	9545-008-027	9545-008-027	9545-008-027	9545-008-027	3
*	Screw #8-32 X3/8	9545-010-006	9545-010-006	9545-010-006	9545-010-006	9545-010-006	2
*	Screw Hex 8B X1/4	9545-045-001	9545-045-001	9545-045-001	9545-045-001	9545-045-001	4
*	Terminal Strip Marker	9558-027-001	9558-027-001	9558-027-001	9558-027-001	9558-027-001	1
6	Thermoactuator, 24V	9586-001-003	9586-001-003	9586-001-003	9586-001-003	9586-001-003	2
*	Wiring Harness, Power Terminal Block	9627-865-001	9627-865-001	9627-865-002	9627-865-002	9627-865-002	1
*	Controls Assembly - Trough,	9857-150-008	9857-150-010	9857-151-015	9857-151-016	9857-152-008	1
*	Door Lock Solenoid Assembly	9922-011-005	9922-011-005	9922-011-005	9922-011-005	9922-011-005	1
*	Filter Mounting Plate Assembly	9982-359-001	9982-349-001	9982-349-001	9982-349-001	9982-349-001	1
*	Nut #6-32	8640-413-002	8640-413-002	8640-413-002	8640-413-002	8640-413-002	4
*	EMI Filter 1 ph, 20 Amp	9183-040-001	9183-040-001	9183-040-001	9183-040-001	9183-040-001	1

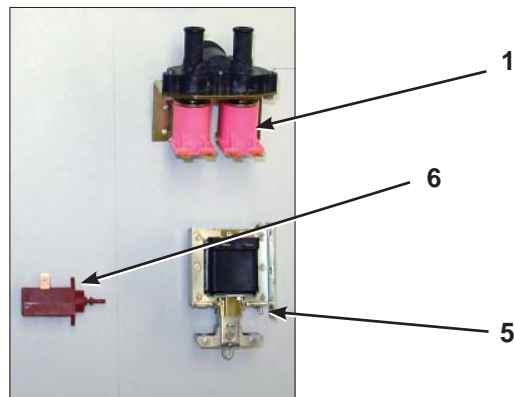
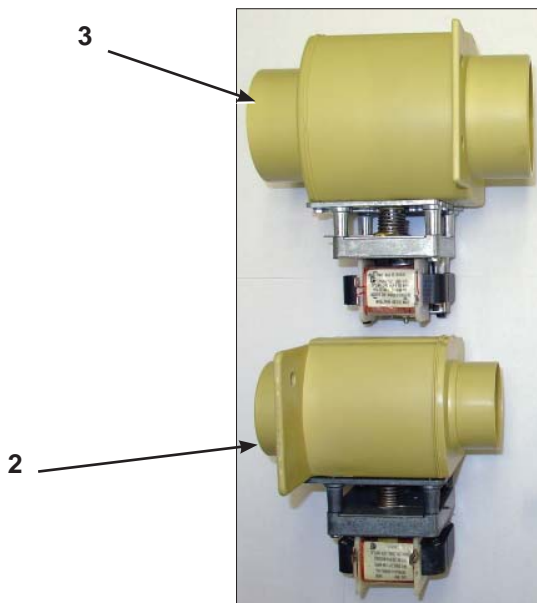

# Transformers and Coin Handling -21 Models

KEY	Part Description	QTY	WCAD-20KCS-21	WCAD20KCS-21SZ	WCAD30KCS-21	WCAD30KCS-21SZ	WCAD-40KCS-21
*	Wire Assembly -Orange/White	1	8220-001-235	8220-001-235	8220-001-235	8220-001-235	8220-001-235
*	Wire Assembly -Blue	1	8220-001-338	8220-001-338	8220-001-338	8220-001-338	8220-001-338
*	Label-Warning, Electronic Coinacceptor	1	8502-730-001	8502-730-001	8502-730-001	8502-730-001	8502-730-001
*	Lockwasher-Exttooth,#6	4	8641-582-005	8641-582-005	8641-582-005	8641-582-005	8641-582-005
1	Transformer-120/18vac	1	8711-015-001	8711-015-001	8711-015-001	8711-015-001	8711-015-001
2	Transformer, Control	1	8711-004-002	8711-004-002	8711-004-002	8711-004-002	8711-004-002
3	Transformer, Secondary	1	8711-009-002	8711-009-002	8711-009-002	8711-009-002	8711-009-002
4	Acceptor-Coin,Electronic	1	9021-011-001	9021-011-001	9021-011-001	9021-011-001	9021-011-001
5	Chute-Coin	1	9119-031-001	9119-031-001	9119-030-001	9119-028-001	9119-028-001
*	Wiringlabel-Schematic	1	9506-405-001	9506-409-001	9506-413-001	9506-415-001	9506-423-001
*	Wiringlabel-Diagram	1	9506-406-001	9506-410-001	9506-414-001	9506-414-001	9506-424-001
*	Screw-Hx 10bx1/4	7	9545-008-001	9545-008-001	9545-008-001	9545-008-001	9545-008-001
*	Screw-Hx ,8bx1/4	6	9545-045-001	9545-045-001	9545-045-001	9545-045-001	9545-045-001
6	Harness-Electronic Coin Acceptor	1	9627-845-001	9627-845-001	9627-845-001	9627-845-001	9627-845-001
*	Controlsassembly -Trough	1	9857-150-007	9857-157-009	9857-151-013	9857-151-014	9857-152-007

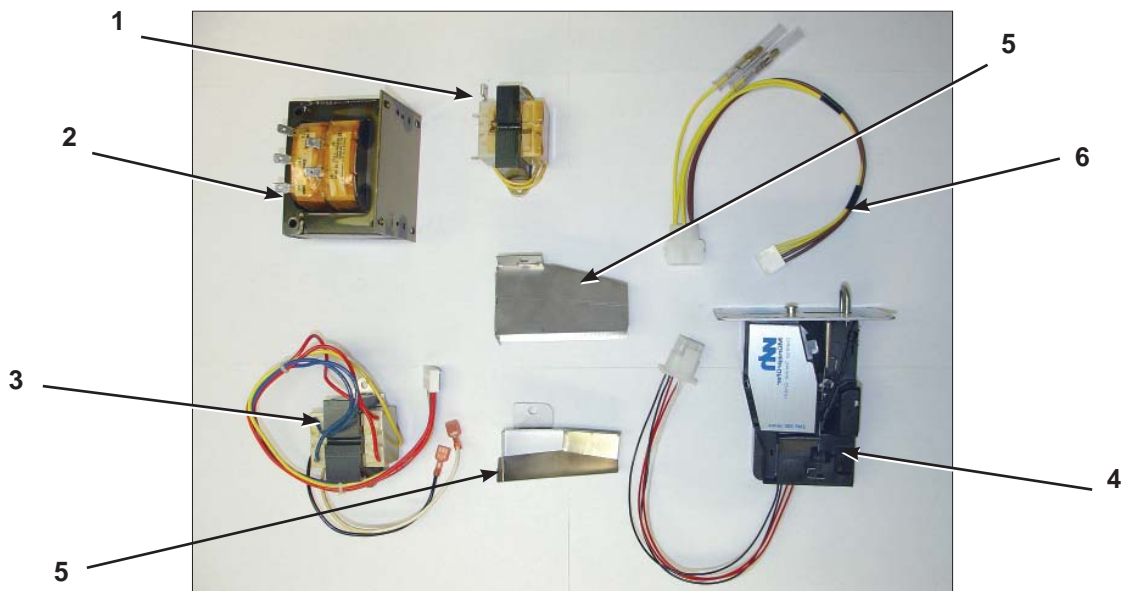



# Double Load 20lb Coin Non-Express: 230/50/1 Voltage Schematic

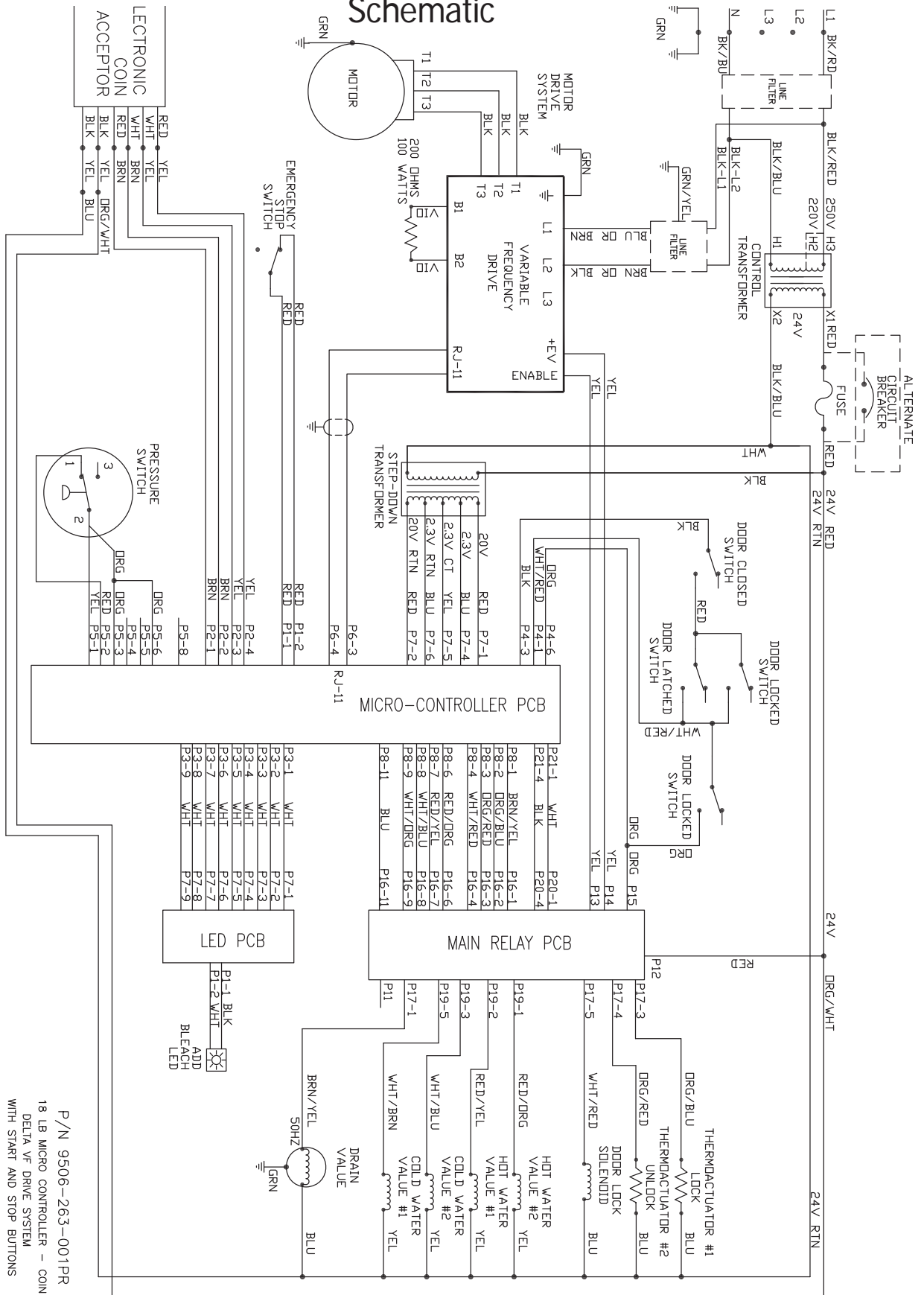

SCHEMATIC - 230V-1PH-50HZ

P/N 9506-263-001PR  
 18 LB MICRO CONTROLLER - COIN  
 DELTA VF DRIVE SYSTEM  
 WITH START AND STOP BUTTONS

# Double Load 20lb Coin Non-Express: 230/50/1 Voltage Diagram

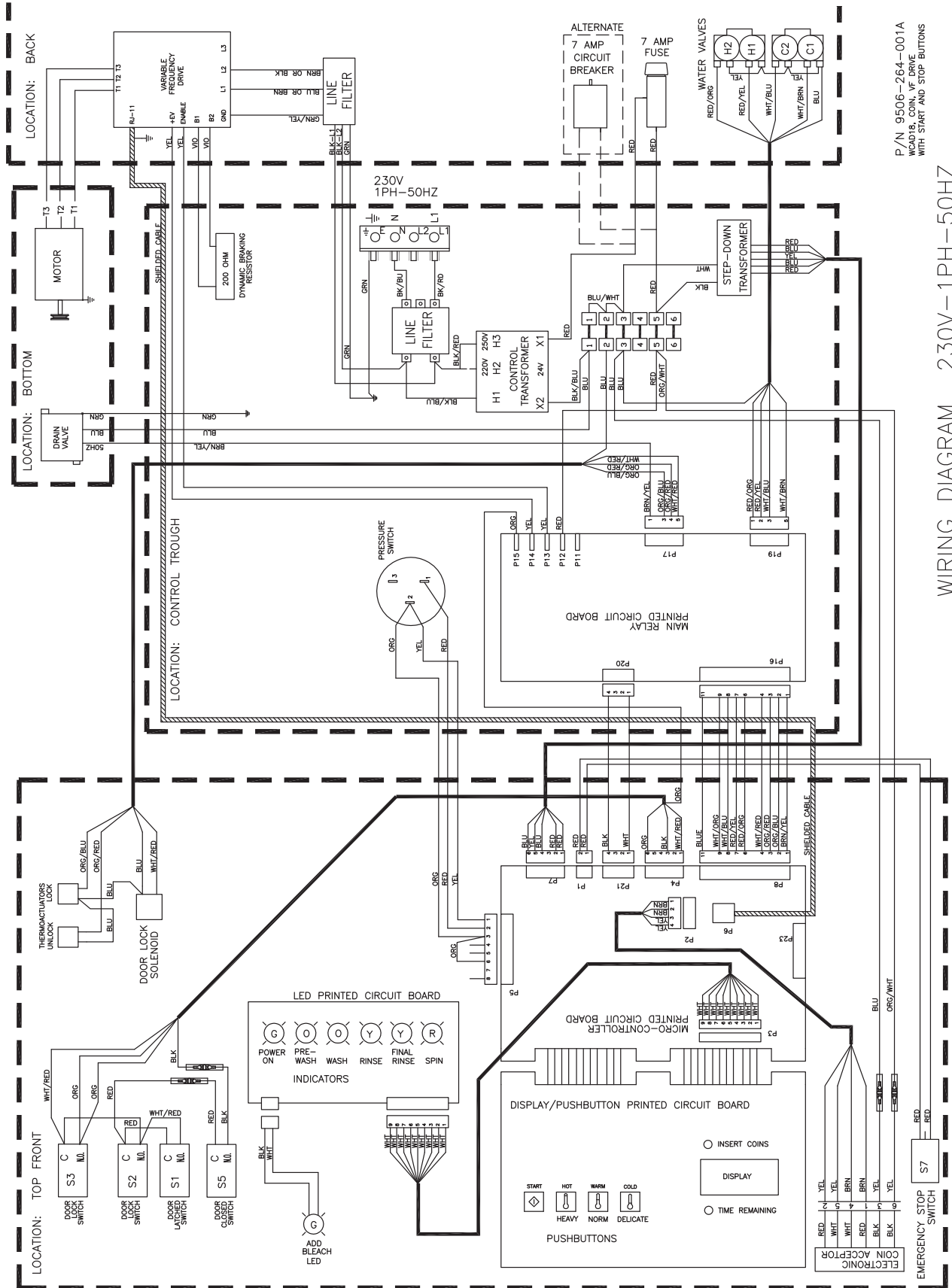

P/N 9506-264-001A  
WARD 8 COIN VFD DRIVE  
WITH START AND STOP BUTTONS

WIRING DIAGRAM 230V-1PH-50HZ

# Double Load 20lb Express: 230V/50/1 Voltage Schematic

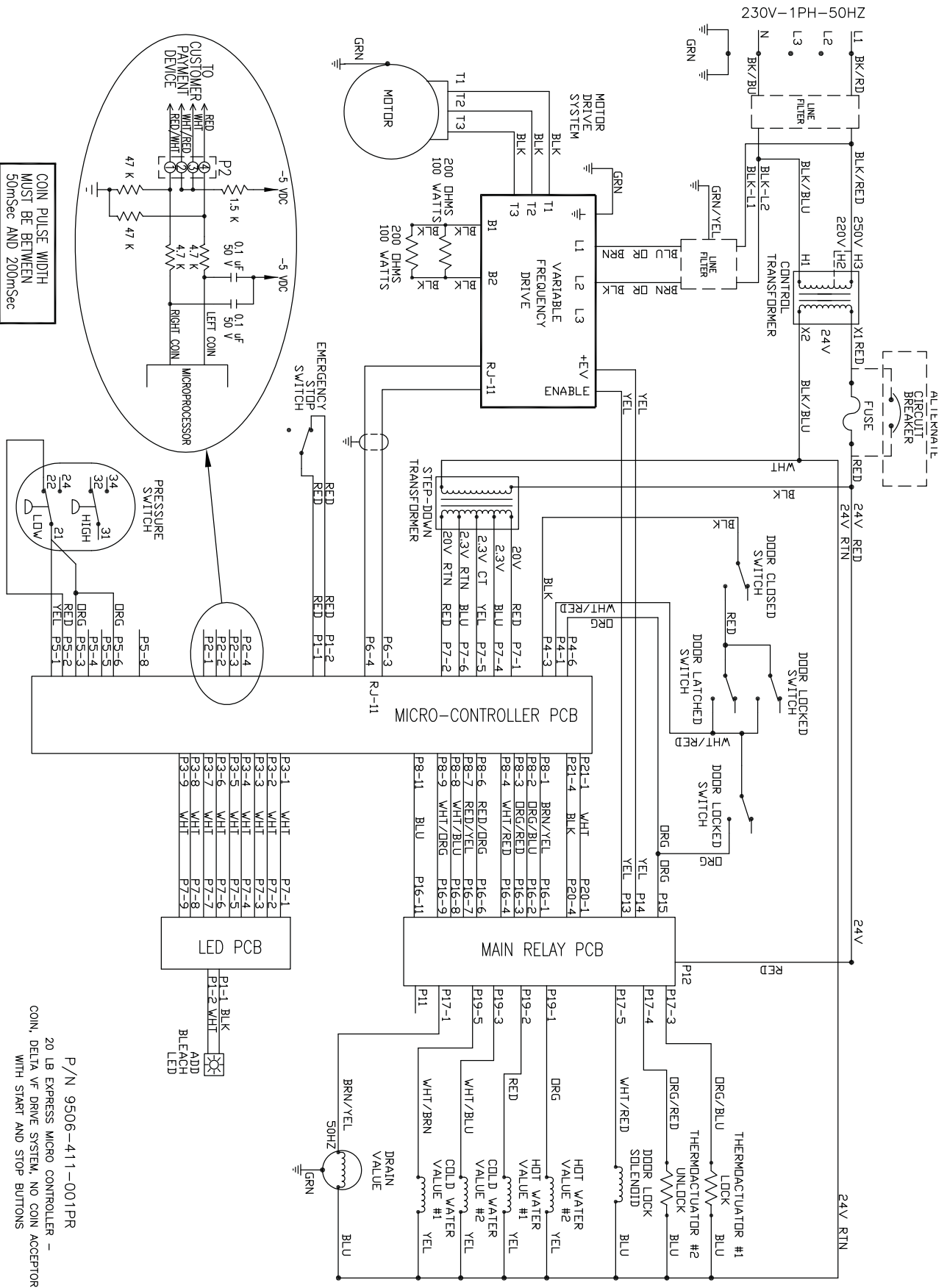

SCHEMATIC - 230V-1PH-50HZ

P/N 9506-411-001PR  
 20 LB EXPRESS MICRO CONTROLLER -  
 COIN, DELTA VF DRIVE SYSTEM, NO COIN ACCEPTOR  
 WITH START AND STOP BUTTONS



# Double Load 20lb Express: 230V/50/1 Voltage Diagram

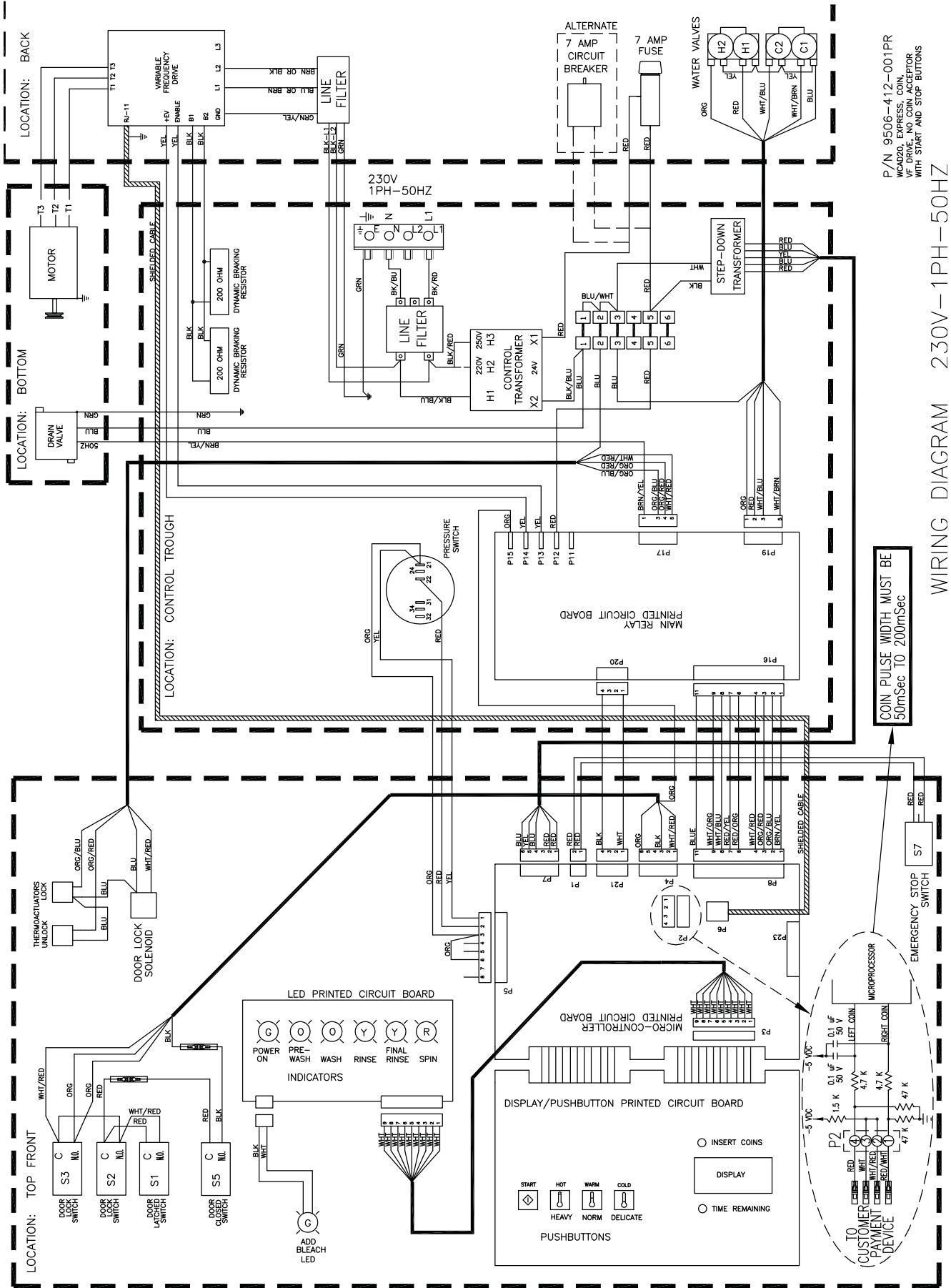

P/N 9506-412-001PR  
 WASH/EXPRESS CONTROL BOARD  
 WITH START AND STOP BUTTONS

WIRING DIAGRAM 230V-1PH-50HZ

COIN PULSE WIDTH MUST BE  
 50mSec TO 200mSec

# Triple Load 30lb Non-Express & Express: 230/50/1 Voltage Schematic

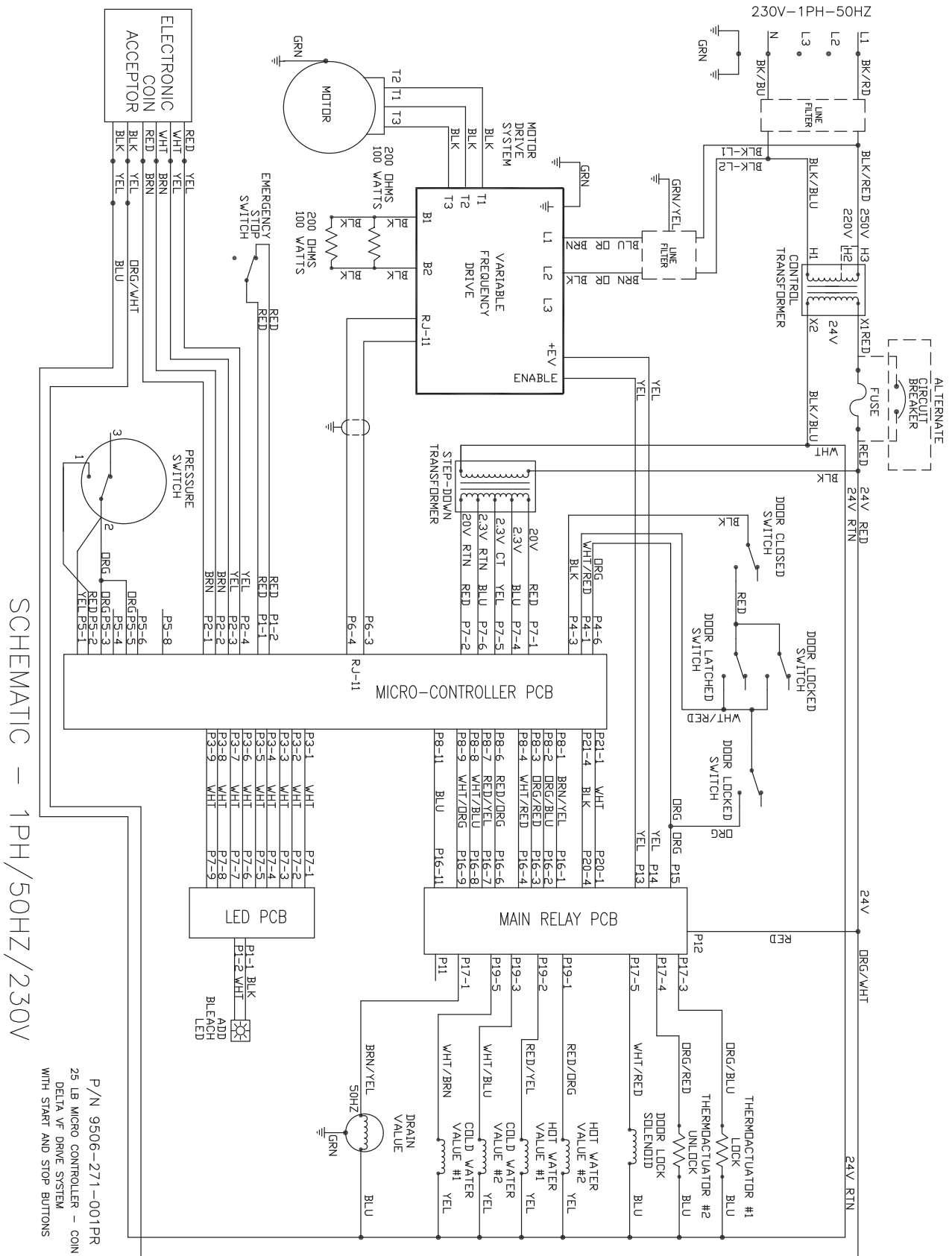

SCHEMATIC - 1PH/50HZ/230V

P/N 9506-271-001PR  
 25 LB MICRO CONTROLLER - COIN  
 DELTA VF DRIVE SYSTEM  
 WITH START AND STOP BUTTONS

# Triple Load 30lb Non-Express & Express: 230/50/1 Voltage Diagram

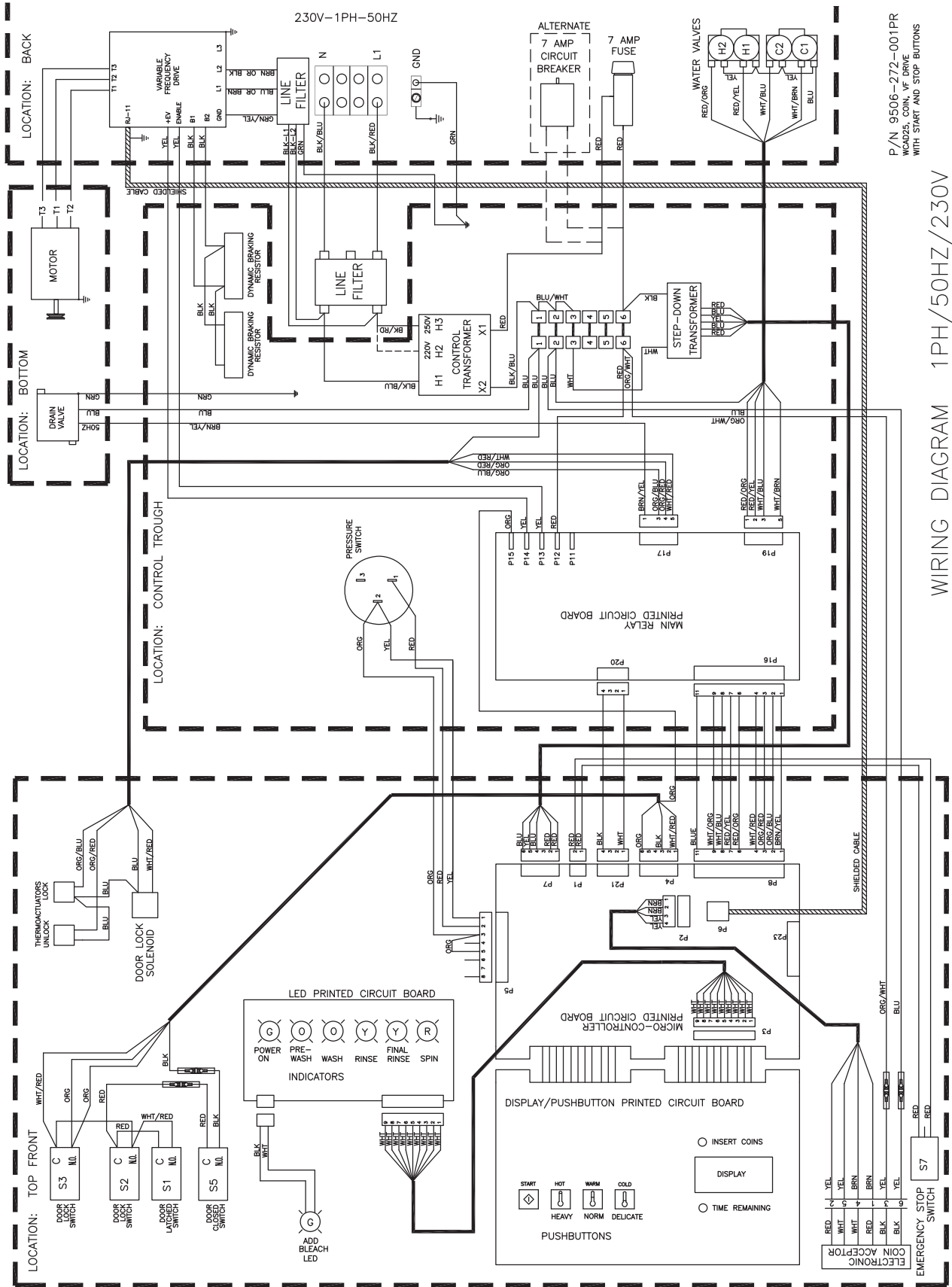

# Maxi Load 40lb Non-Express: 230/50/1 Voltage Schematic

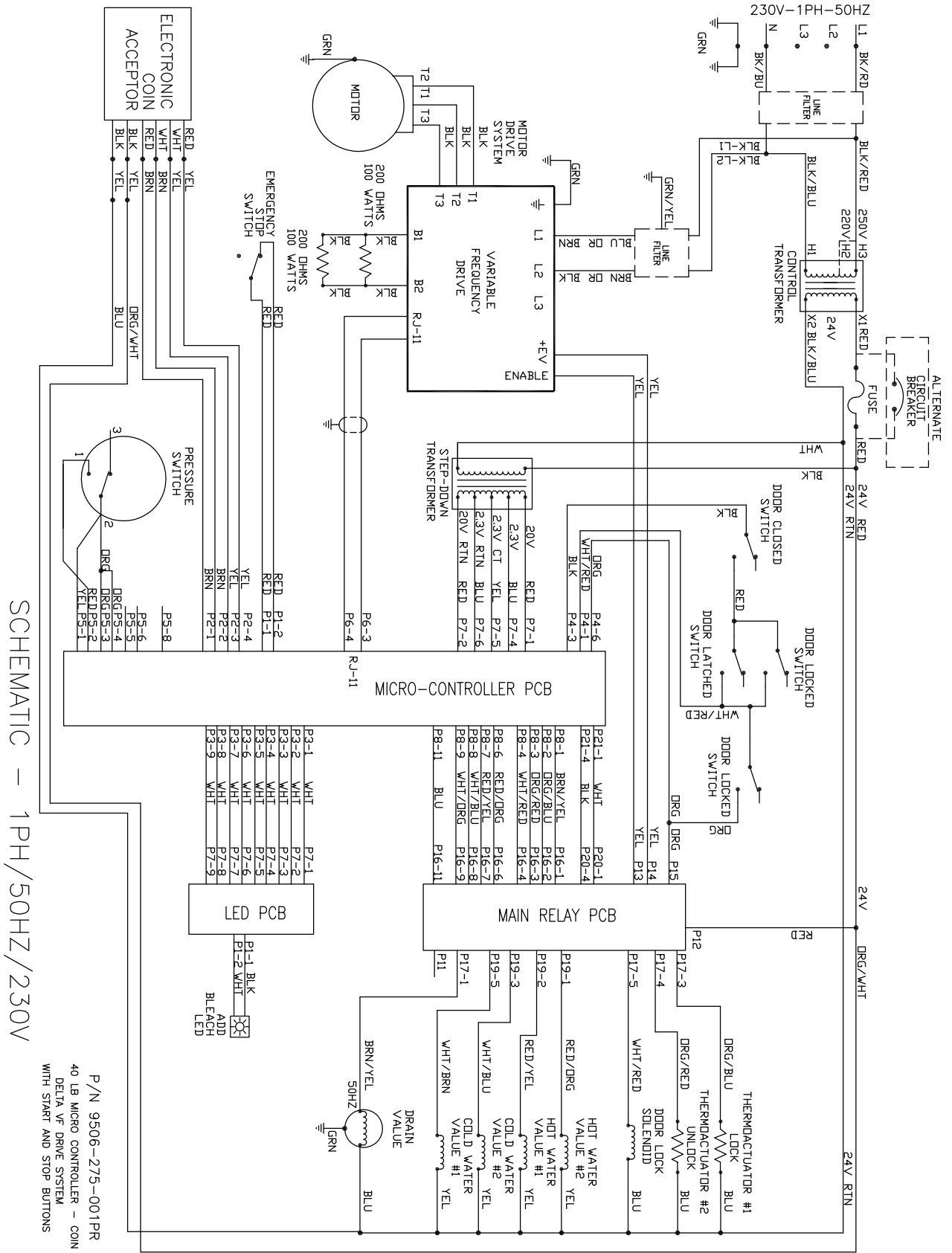

# Maxi Load 40lb Non-Express: 230/50/1 Voltage Diagram

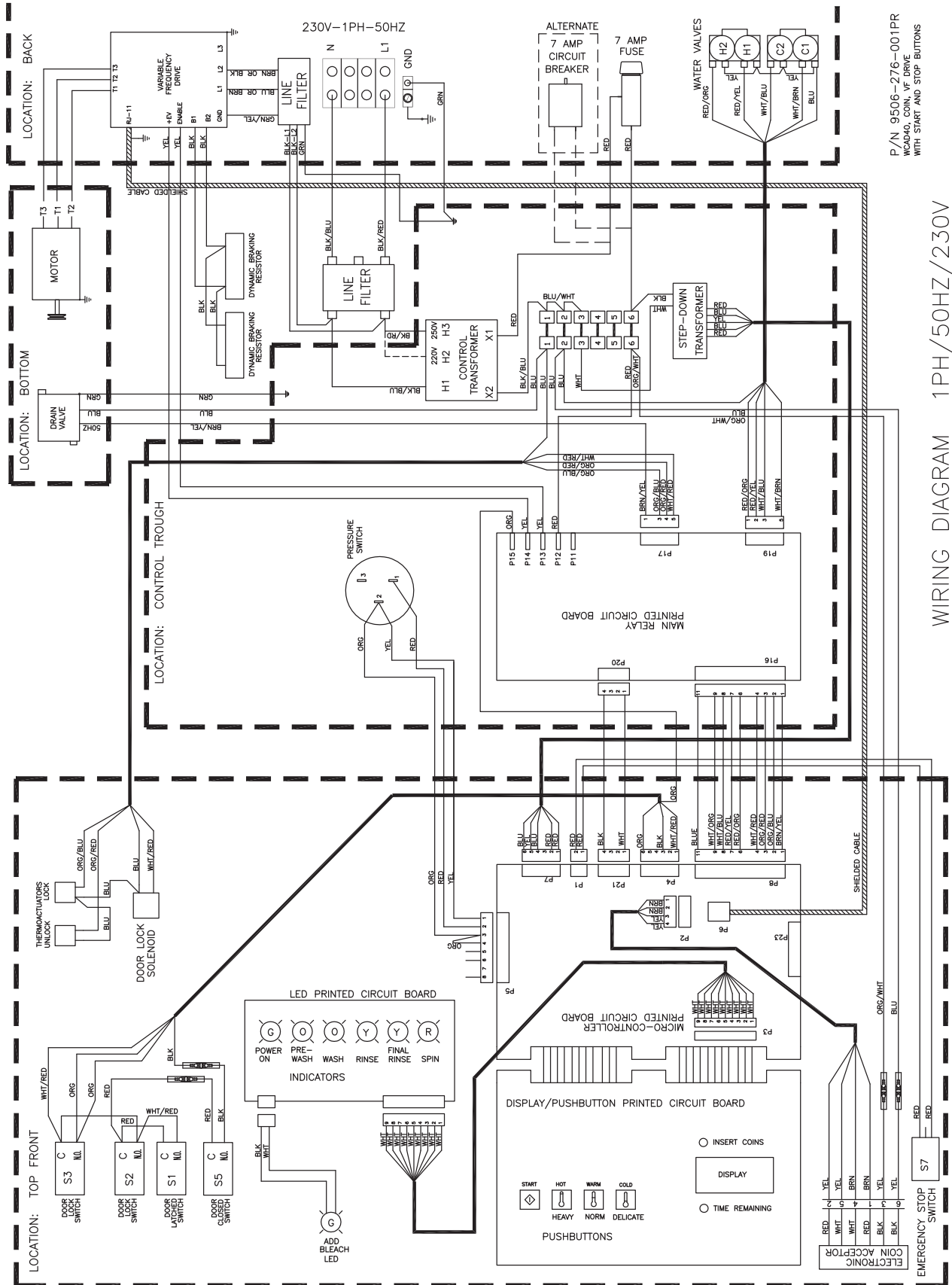

P/N 9506-276-001PR  
W0400, COIN, VF DRIVE  
WITH START AND STOP BUTTONS

WIRING DIAGRAM 1PH/50HZ/230V

---

Notes

A series of horizontal lines for writing notes.

# CN (No Coin Acceptor) 20Lb. non-Express: 120 Volt Wiring Schematic

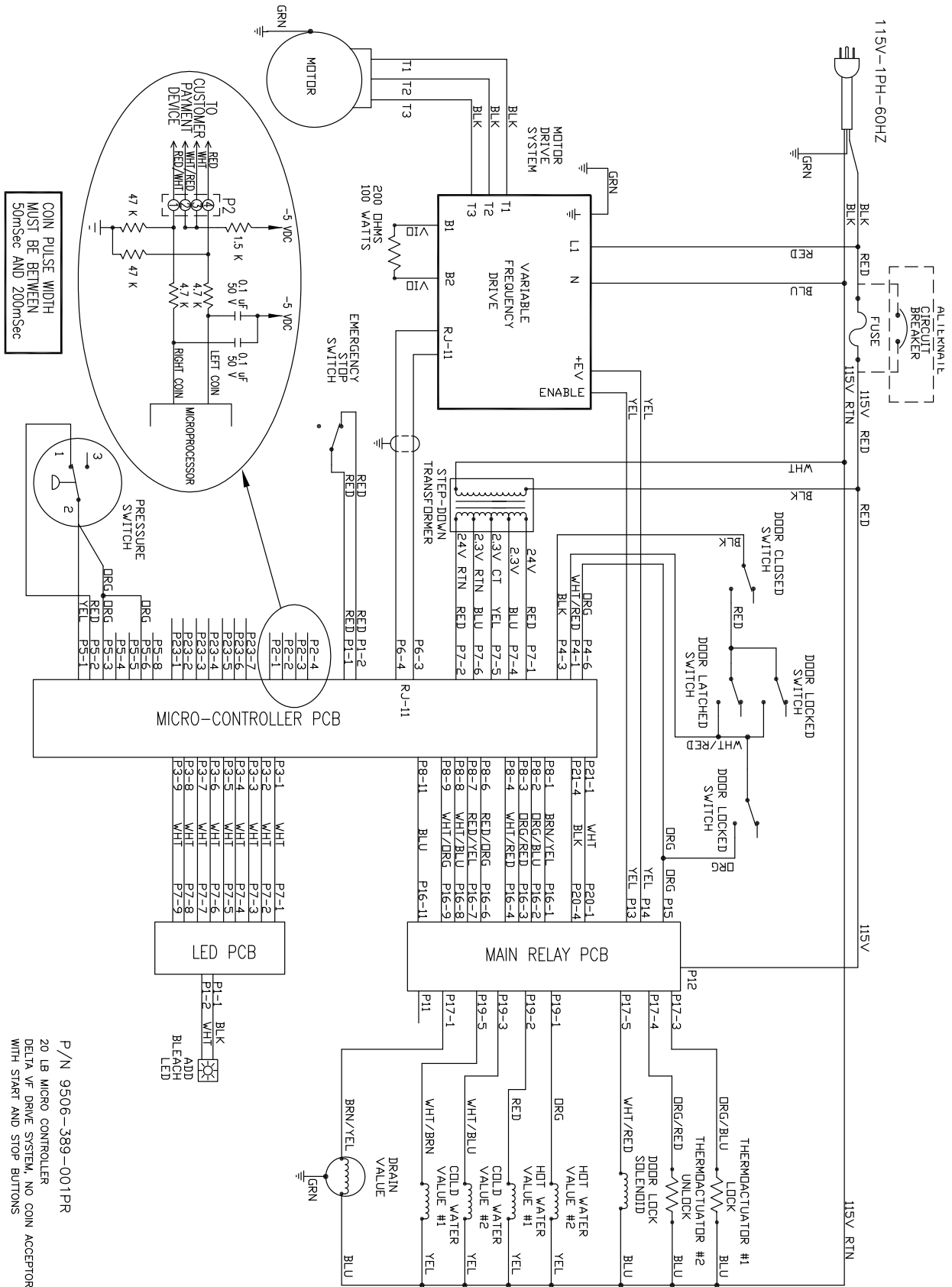

SCHEMATIC

115-1PH-60HZ

# CN (No Coin Acceptor) 20Lb. non-Express: 120 Volt Wiring Diagram

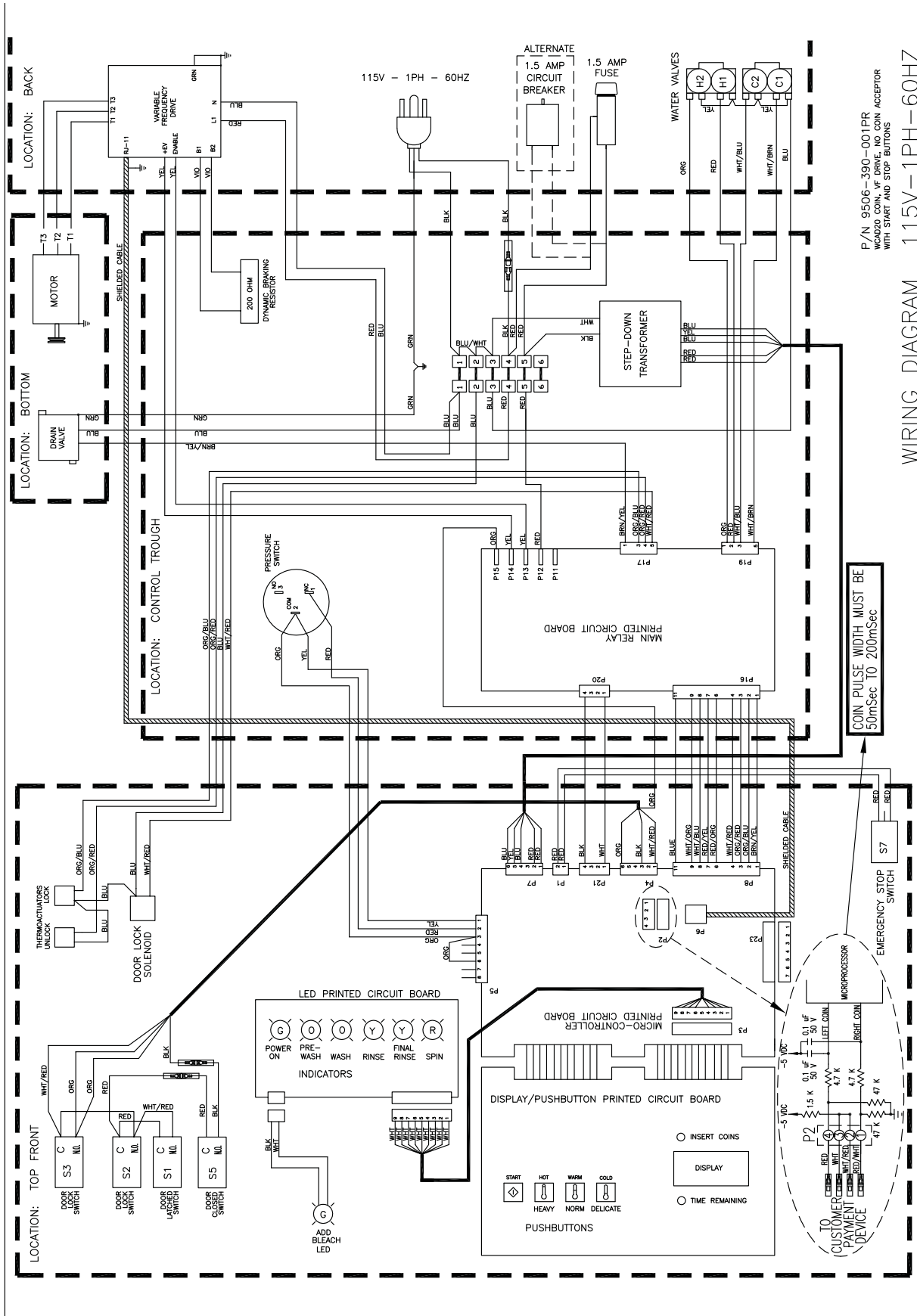



# CN (No Coin Acceptor) 20Lb. Non-Express: 208-240V Schematic

208-240V-3PH OR 1PH-60HZ

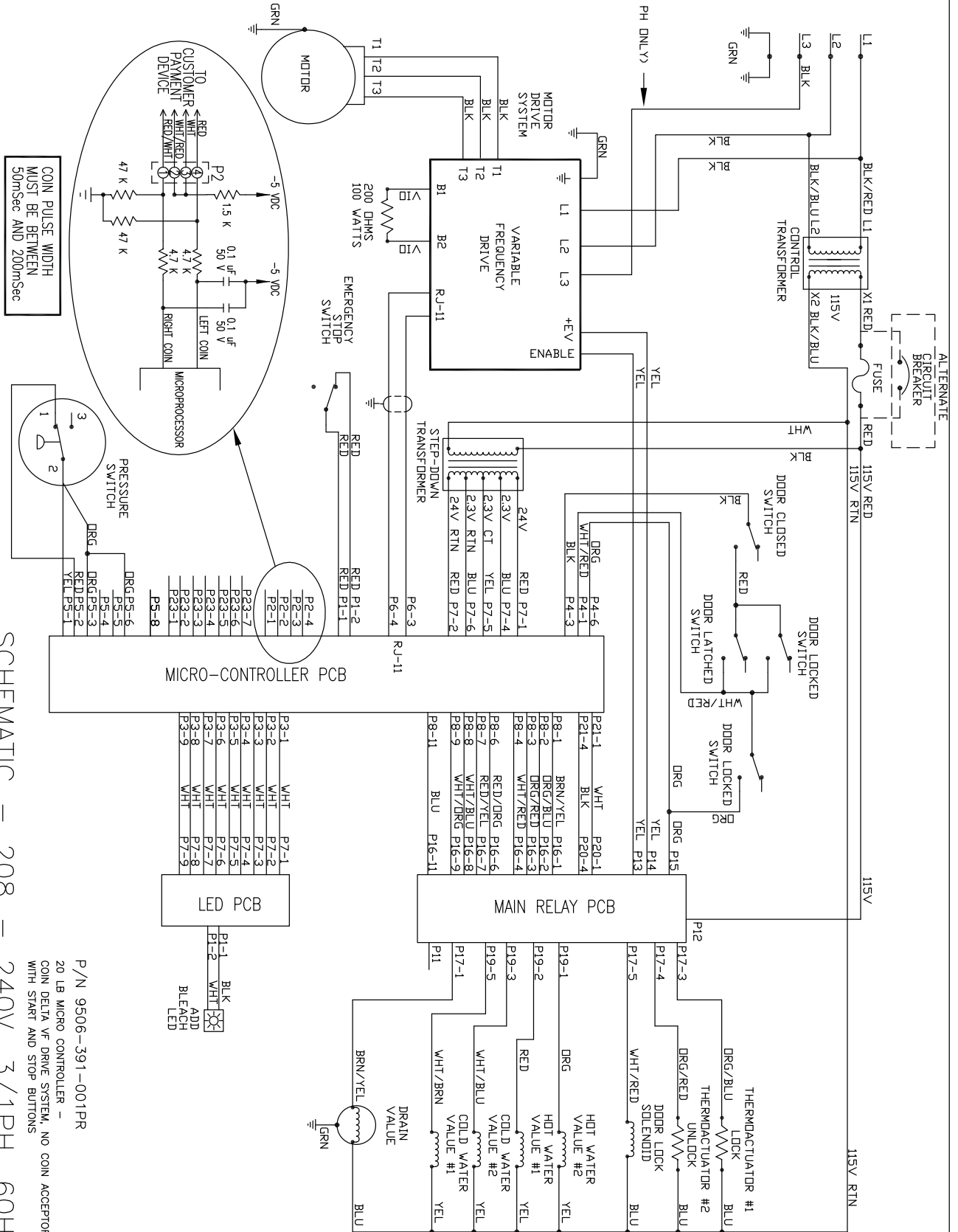

# CN (No Coin Acceptor) 20Lb. Non-Express: 208-240 Volt Wiring Diagram

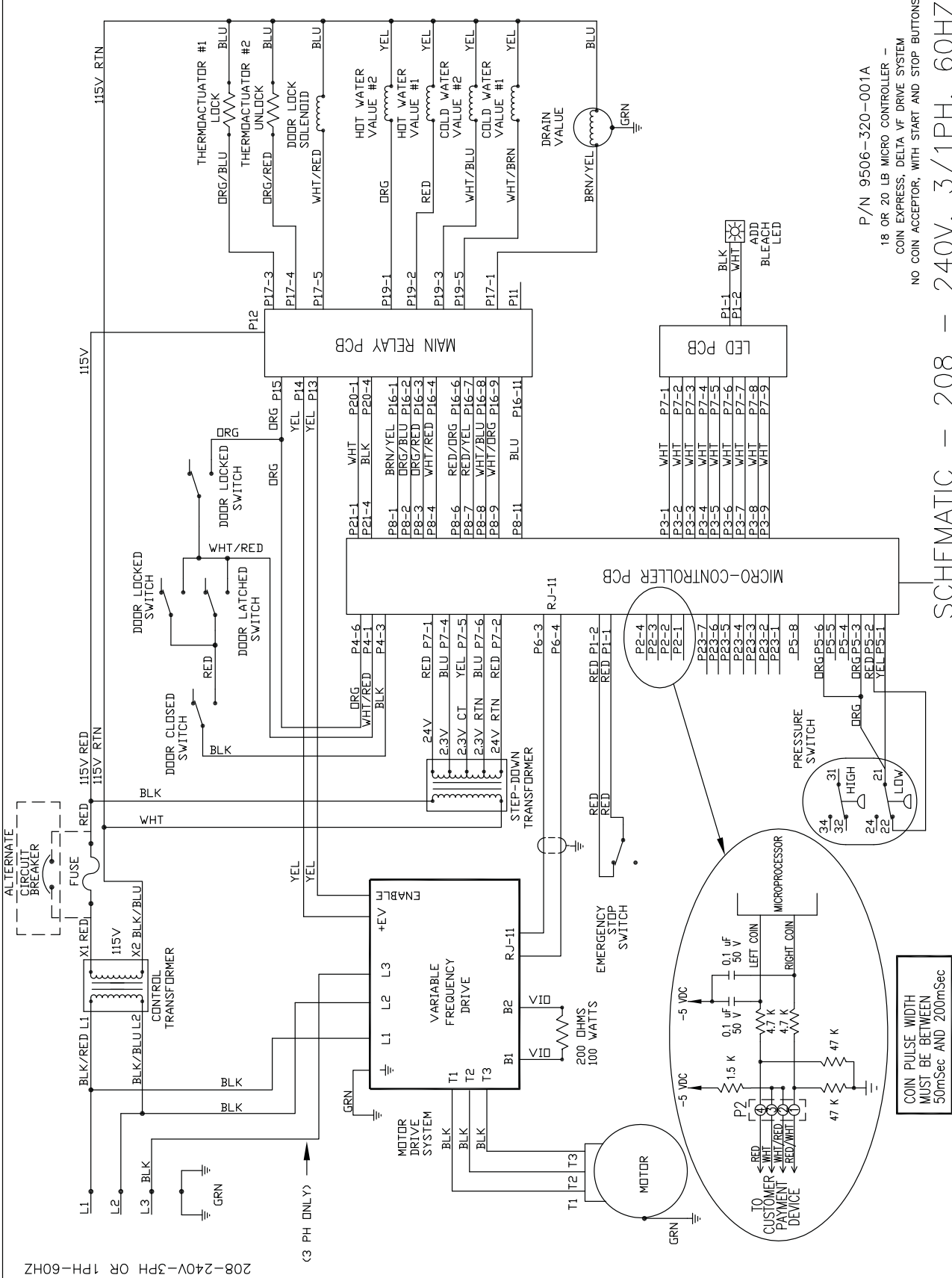

P/N 9506-320-001A  
18 OR 20 LB MICRO CONTROLLER -  
COIN EXPRESS, DELTA VF DRIVE SYSTEM  
NO COIN ACCEPTOR, WITH START AND STOP BUTTONS

SCHEMATIC - 208 - 240V, 3/1PH, 60HZ

COIN PULSE WIDTH  
MUST BE BETWEEN  
50mSec AND 200mSec

208-240V-3PH OR 1PH-60HZ

# CN (No Coin Acceptor) 20Lb. Express: 208-240 Wiring Schematic

208-240V-3PH OR 1PH-60HZ

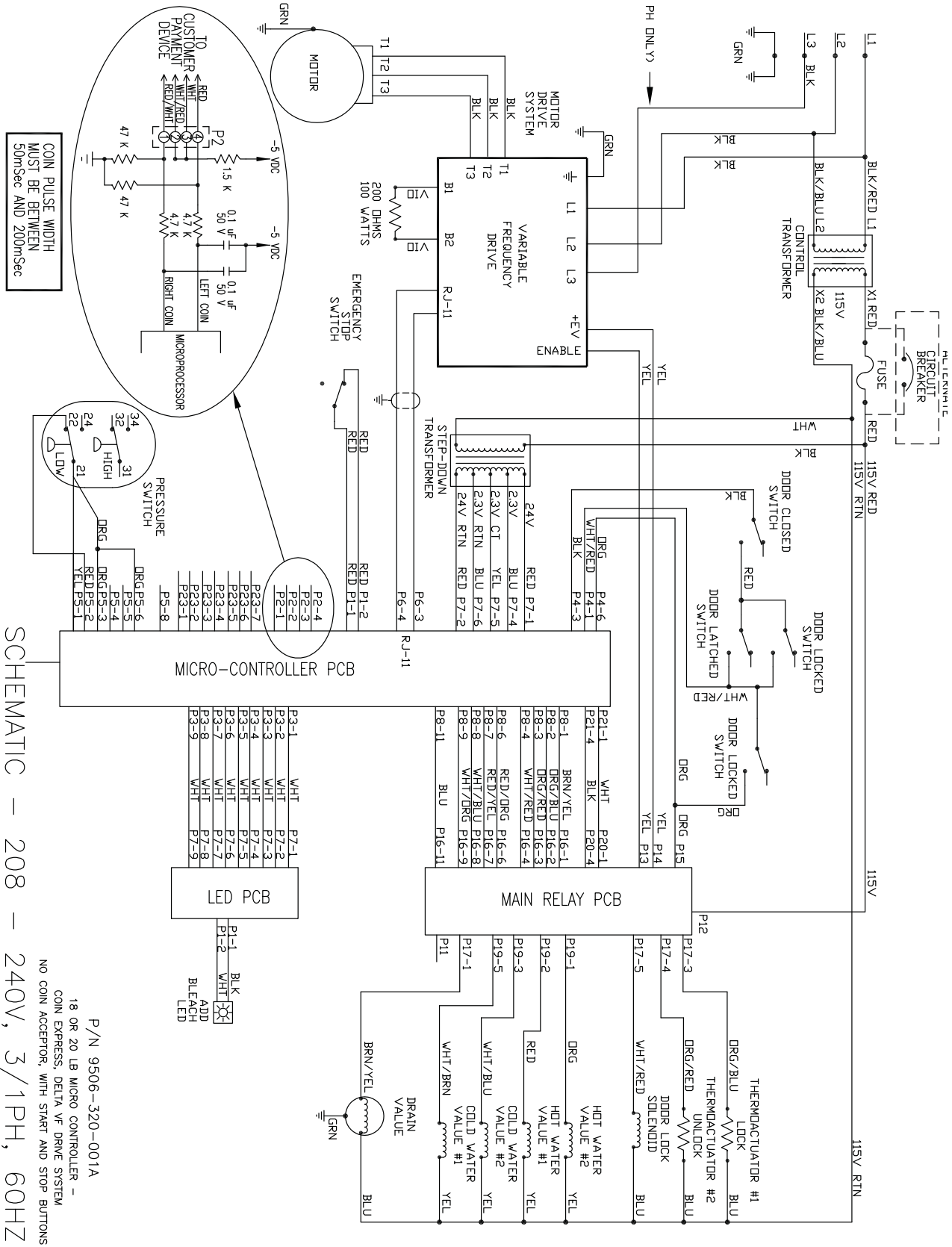

# CN (No Coin Acceptor) 20Lb. Express: 208-240 Wiring Diagram

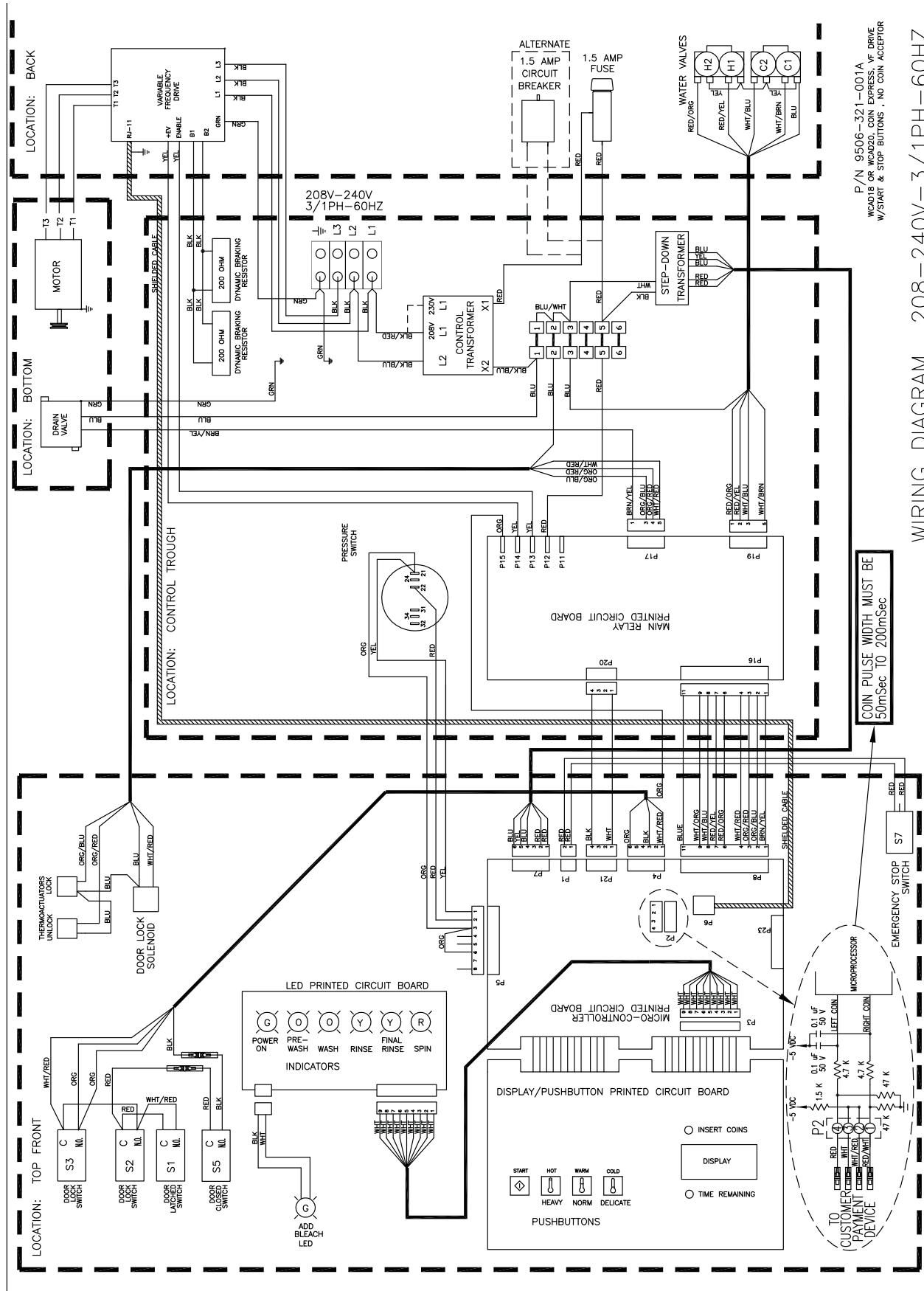

WIRING DIAGRAM 208-240V-3/1PH-60HZ

# 30Lb. Express: Non-Express & Express: CN (No Coin Acceptor) Schematic 208-240

208-240V-3PH

OHZ

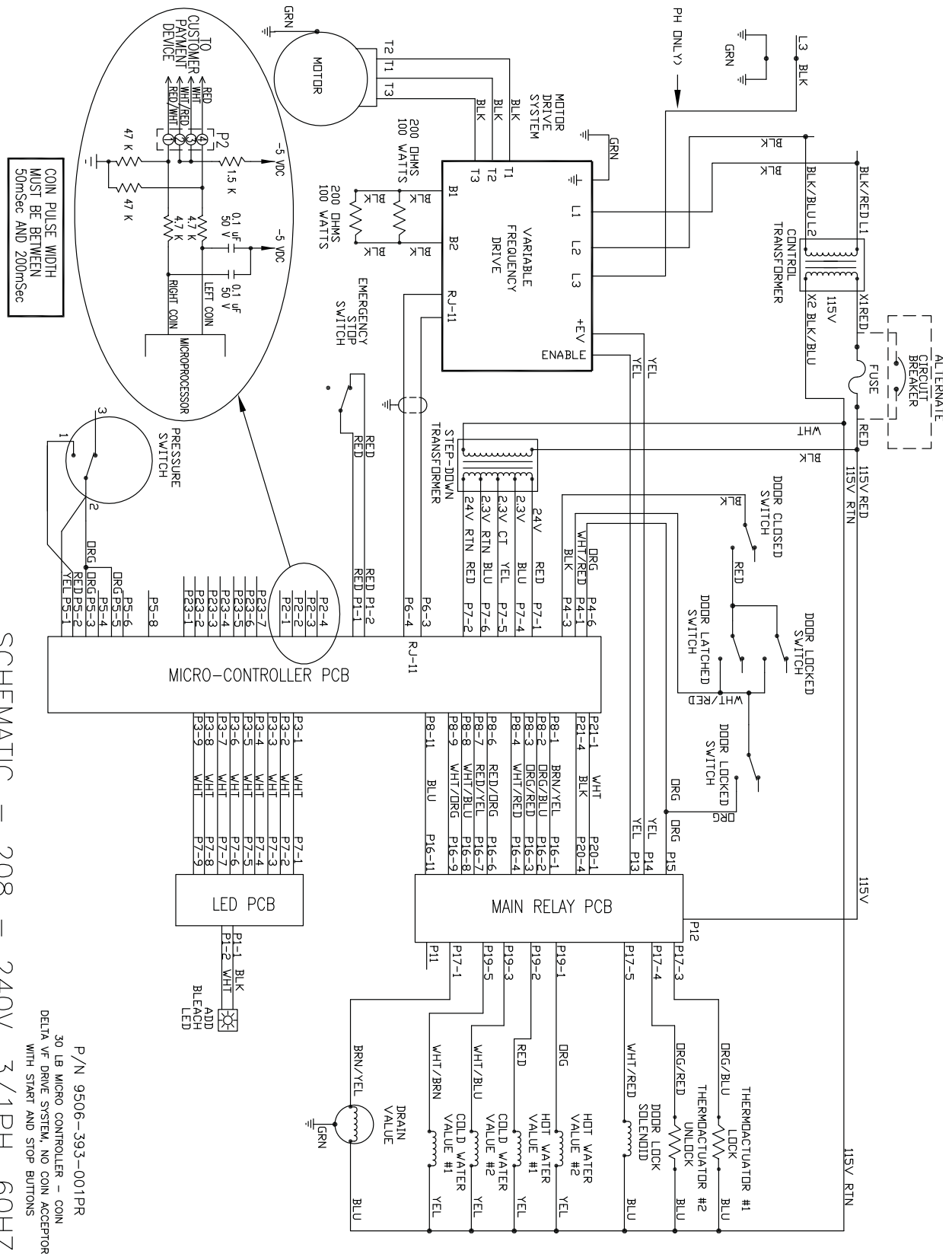

# 30Lb. Express: Non-Express & Express: CN (No Coin Acceptor) Schematic 208-240

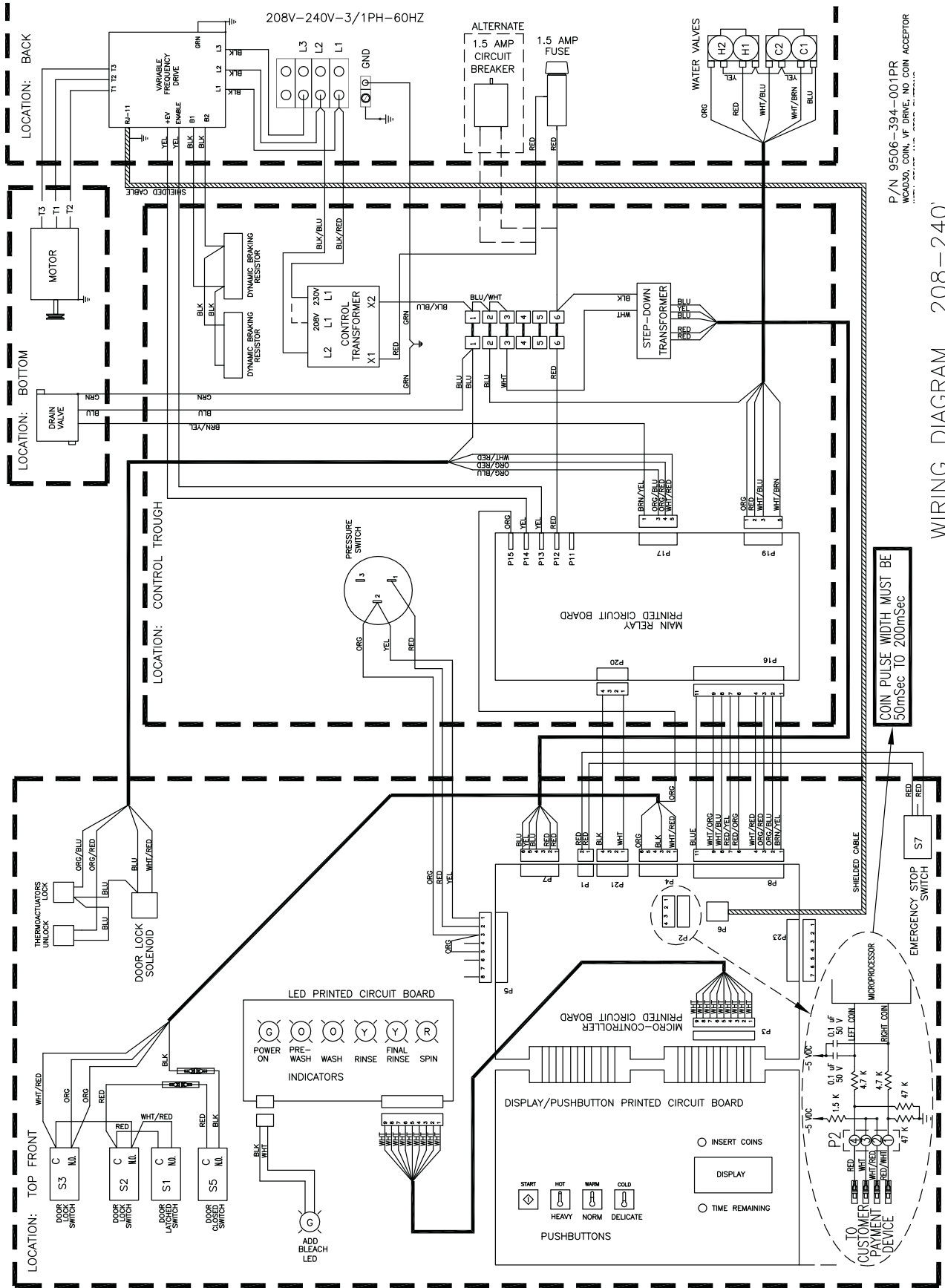

P/N 9506-394-001PR  
WCAC30, COIN, VF DRIVE, NO COIN ACCEPTOR

# 40Lb. Express: Non-Express: CN (No Coin Acceptor) Schematic 208-240

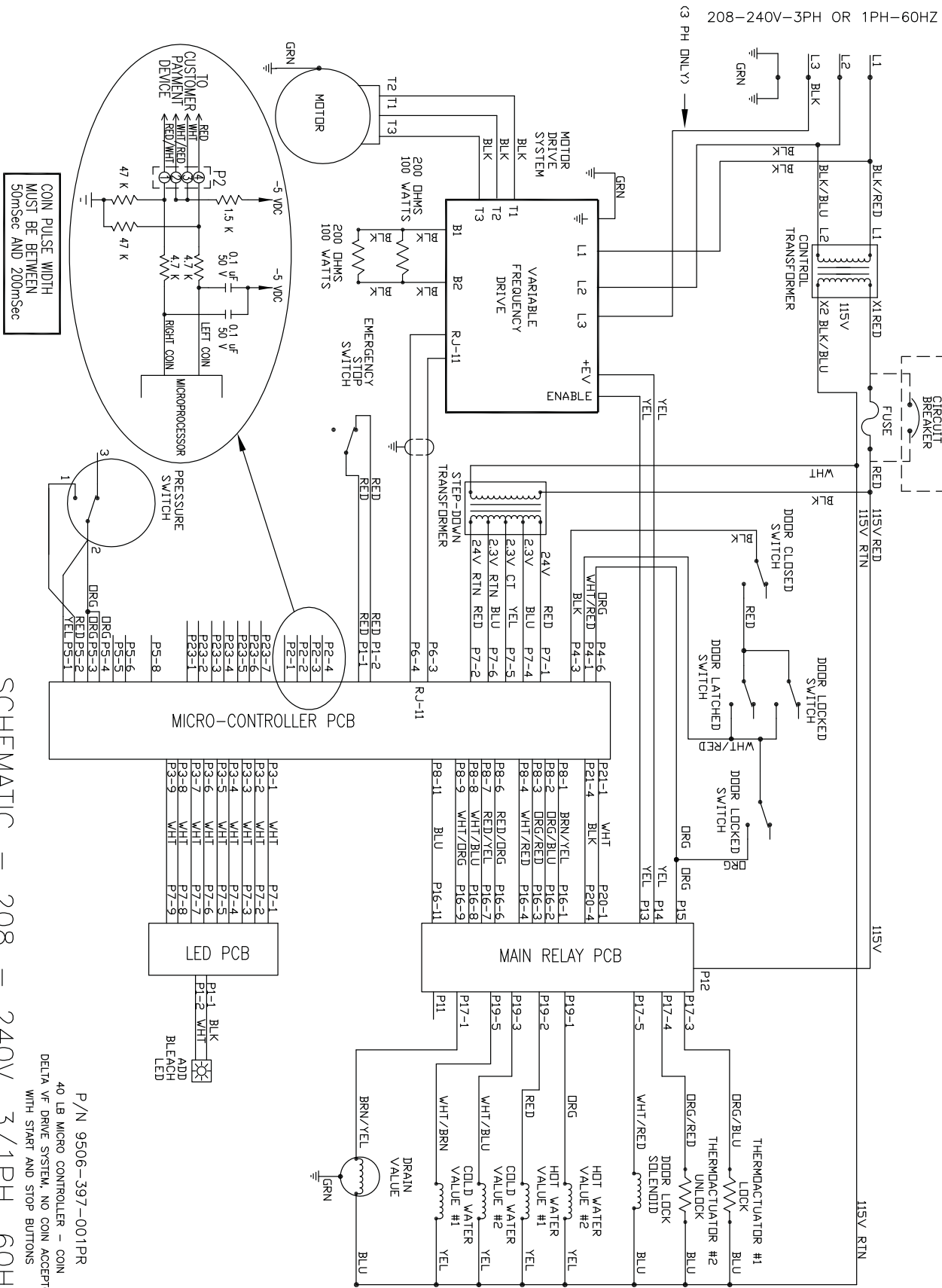

SCHEMATIC -- 208 -- 240V, 3/1PH, 60HZ

P/N 9506-397-001PR  
 40 LB MICRO CONTROLLER -- COIN  
 DELTA V/F DRIVE SYSTEM, NO COIN ACCEPTOR  
 WITH START AND STOP BUTTONS

# 40Lb. Express: Non-Express CN (No Coin Acceptor) Schematic 208-240

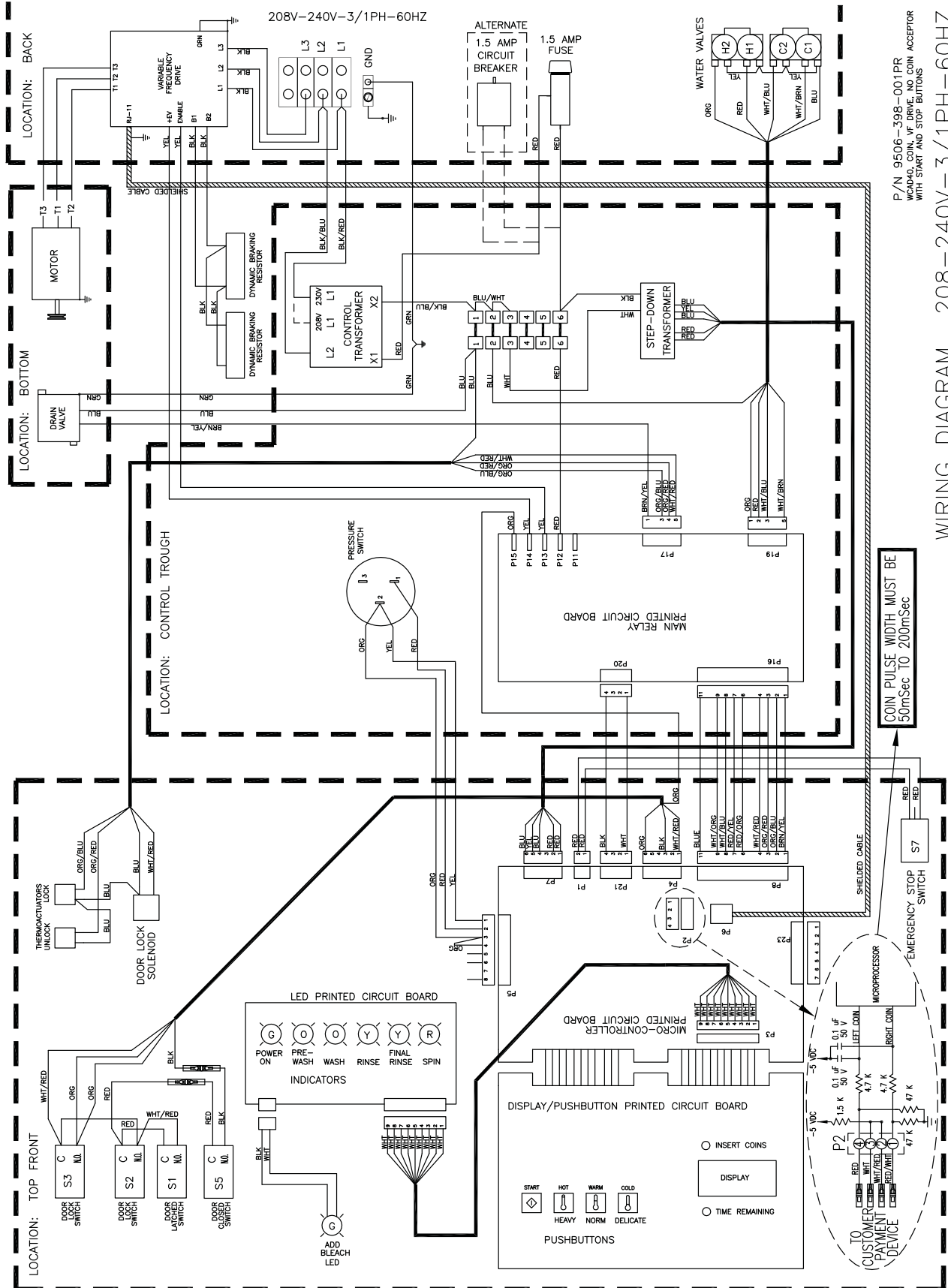

P/N 9506-398-001 PR  
W/40LB. CN, 1.5 AMP FUSE, 1.5 AMP CIRCUIT BREAKER, AND COIN ACCEPTOR WITH START AND STOP BUTTONS

WIRING DIAGRAM 208-240V-3/1PH-60HZ