



ADG-385 / WDA-385

Parts Manual

24 VAC Phase 5

1996 / 1997

American Dryer Corporation
88 Currant Road
Fall River MA 02720-4781 USA
Telephone: +1 (508) 678-9000 / Fax: +1 (508) 678-9447
e-mail: techsupport@amdry.com

www.adclaundry.com

Retain This Manual In A Safe Place For Future Reference

American Dryer Corporation products embody advanced concepts in engineering, design, and safety. If this product is properly maintained, it will provide many years of safe, efficient, and trouble free operation.

ONLY qualified technicians should service this equipment.

OBSERVE ALL SAFETY PRECAUTIONS displayed on the equipment or specified in the installation manual included with the dryer.

The following “**FOR YOUR SAFETY**” caution must be posted near the dryer in a prominent location.

FOR YOUR SAFETY

Do not store or use gasoline or other flammable vapors and liquids in the vicinity of this or any other appliance.

POUR VOTRE SÉCURITÉ

Ne pas entreposer ni utiliser d'essence ni d'autres vapeurs ou liquides inflammables à proximité de cet appareil ou de tout autre appareil.

We have tried to make this manual as complete as possible and hope you will find it useful. ADC reserves the right to make changes from time to time, without notice or obligation, in prices, specifications, colors, and material, and to change or discontinue models.

Important

For your convenience, log the following information:

DATE OF PURCHASE _____ MODEL NO. _____

RESELLER'S NAME _____

Serial Number(s) _____

Replacement parts can be obtained from your reseller or the ADC factory. When ordering replacement parts from the factory, you can FAX your order to ADC at (508) 678-9447 or telephone your order directly to the ADC Parts Department at (508) 678-9000. Please specify the dryer model number and serial number in addition to the description and part number, so that your order is processed accurately and promptly.

The illustrations on the following pages may not depict your particular dryer exactly. The illustrations are a composite of the various dryer models. Be sure to check the descriptions of the parts thoroughly before ordering.

“IMPORTANT NOTE TO PURCHASER”

Information must be obtained from your local gas supplier on the instructions to be followed if the user smells gas. These instructions must be posted in a prominent location near the dryer.

Table of Contents

High Security Control Door Assembly	4
Phase 5 Coin Microprocessor Control Panel Assembly	5
Phase 5 Microprocessor Control Box Assembly	6
Coin Vault Assembly	7
Main Door "Steel" Assembly	8
Insulated Front Panel Assembly	10
Main Door Switch Assembly	11
Drop Lint Door Assembly	12
Lint Trap Assembly	13
Tumbler / Support Assemblies	14
Tumbler Bearing Assembly	15
Idler Bearing Assembly	16
Totally Enclosed, Fan-Cooled Motor Mount Assembly	17
Sensor Bracket Assemblies	18
Direct Spark Ignition Burner Assembly	19
ADG-385 Sail Switch / Hi-Limit Assembly	20
Single Phase Motor, Electric Relay Panel Assembly	21
Outer Top / Back Guard Assembly	22
Microprocessor Coin Acceptor Listing	23
ADG-385 Step Down Transformer Usage Listing	24
Additional Parts Available	25

High Security Control Door Assembly

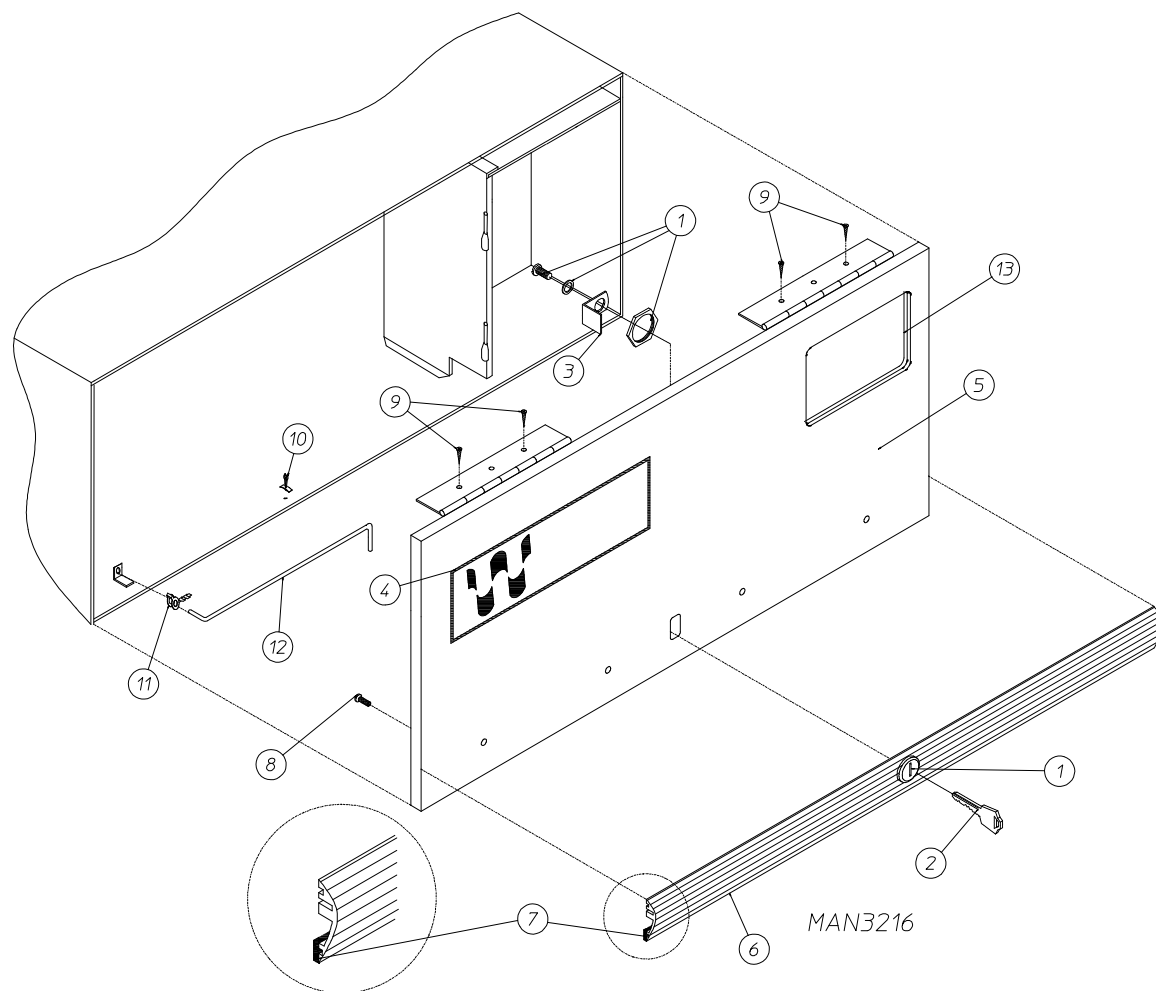

<u>Illus. No.</u>	<u>Part No.</u>	<u>Qty.</u>	<u>Description</u>
1	160038	1	XX4451 Lock Assembly with Hardware
2	160140	1	XX4451 Key ONLY
3	160031	1	Lock Cam
4	112347	1	Wascody Logo
5	881434*	1	High Security Control Door Assembly Less Lock (includes illus. nos. 5 through 8)
	881435*	1	High Security Textured Control Door Assembly Less Lock (includes illus. nos. 5 through 8)
6	180303	1	Top Black Trim Strip with Lock Hole
7	117603	3	Suppressor Tape / Gasket (sold by the foot)
8	150201	4	#10-32 x 1/4" Phillips Round Head Machine Screw
9	150300	4	#10 x 1/2" Hex Washer TEK Screw
10	102600	1	Control Door Support Rod Catch
11	102601	1	Control Door Rod Retainer Clip
12	102505	1	Control Door Support Rod
13	117602	2	Suppressor Tape / Gasket (sold by the foot)

* Specify color when ordering.

Phase 5 Coin Microprocessor Control Panel Assembly

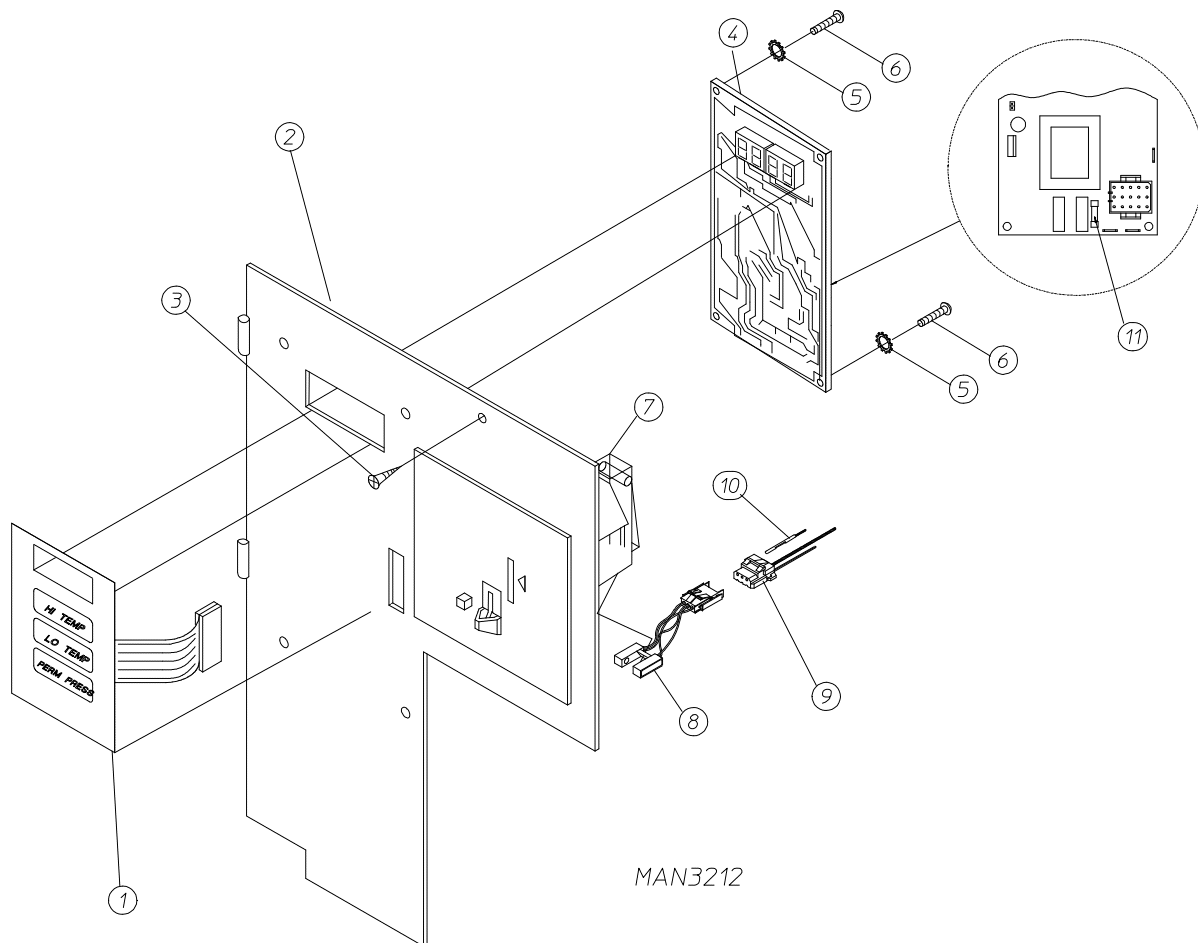

<u>Illus. No.</u>	<u>Part No.</u>	<u>Qty.</u>	<u>Description</u>
1	112526	1	Coin Keypad Label Assembly
2	881506	1	Coin Control Panel Assembly Less Acceptor (includes illus. nos. 1, 2, 4 through 6 and 11)
	881507	1	Coin Control Panel Assembly with Battery Bracket Less Acceptor (includes illus. nos. 1, 2, 4 through 6 and 11)
	881540	1	Coin Control Panel ONLY
	881430	1	Coin Control Panel with Battery Bracket ONLY
3	150309	1	#10-16 x 1/2" Hex Head TEK Crimptite Screw
4	137213	1	Phase 5 Coin Controller ONLY
	824998	1	Phase 5 Battery Clip
5	153010	2	#6 Star Washer
6	150005	2	#6-32 x 1/4" Phillips Round Head Machine Screw
7	—	1	Microprocessor Coin Acceptor with Optical Switch (refer to Microprocessor Coin Acceptor Listing on page 23)
8	137056	1*	Optic Switch ONLY
9	137023	1*	Optic Switch Connector ONLY
10	137021	3*	Microprocessor Socket ONLY
	880772	1	Single Coin Optical Switch Harness
	824080	1	Dual Coin Optical Switch Harness
	122800	1	Microprocessor (female) Pin Extraction Tool
11	136048	1	1/8-Amp (Slo-Blo) Fuse ONLY

* For dual coin models, double the quantity.

Phase 5 Microprocessor Control Box Assembly

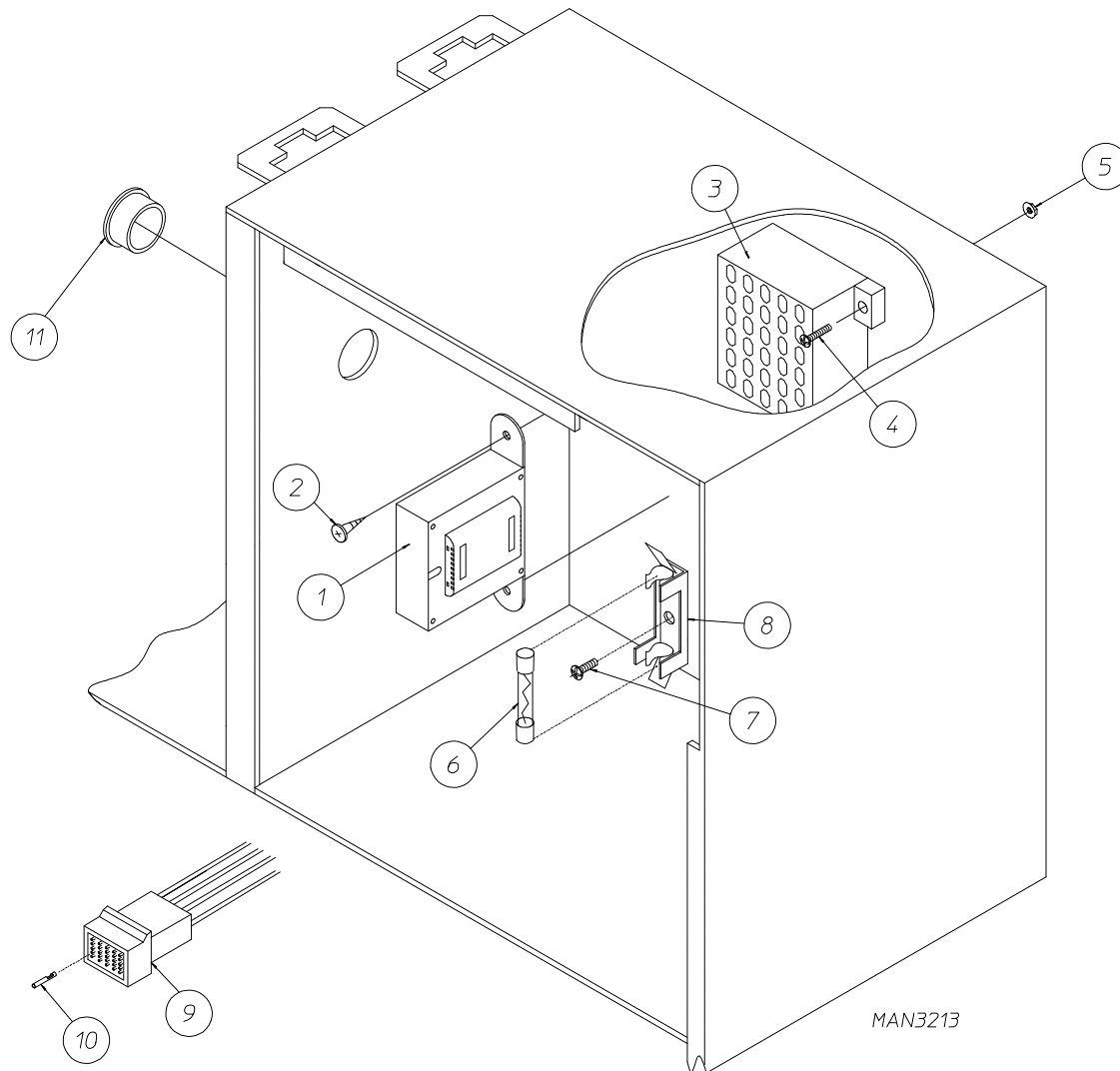

<u>Illus. No.</u>	<u>Part No.</u>	<u>Qty.</u>	<u>Description</u>
1	—	1	Step Down Transformer (refer to ADG-385 Step Down Transformer Usage Listing on page 24)
2	150300	2	#10 x 1/2" Hex Washer TEK Screw
3	120715	1	30-Position Terminal Block
4	150002	2	#6-32 x 1" Slotted Round Head Machine Screw
5	151000	2	#6-32 Pal Nut
6	136057	*	1/2-Amp (Slo-Blo) Fuse
7	150301	*	#8 x 7/16" Phillips Pan Head TEK Screw
8	136008	*	Fuse Block / Strip ONLY
9	122641	1	15-Pin Microprocessor Connector
10	122706	*	Socket Terminal ONLY
11	121400	1	7/8" Universal Bushing

* As required.

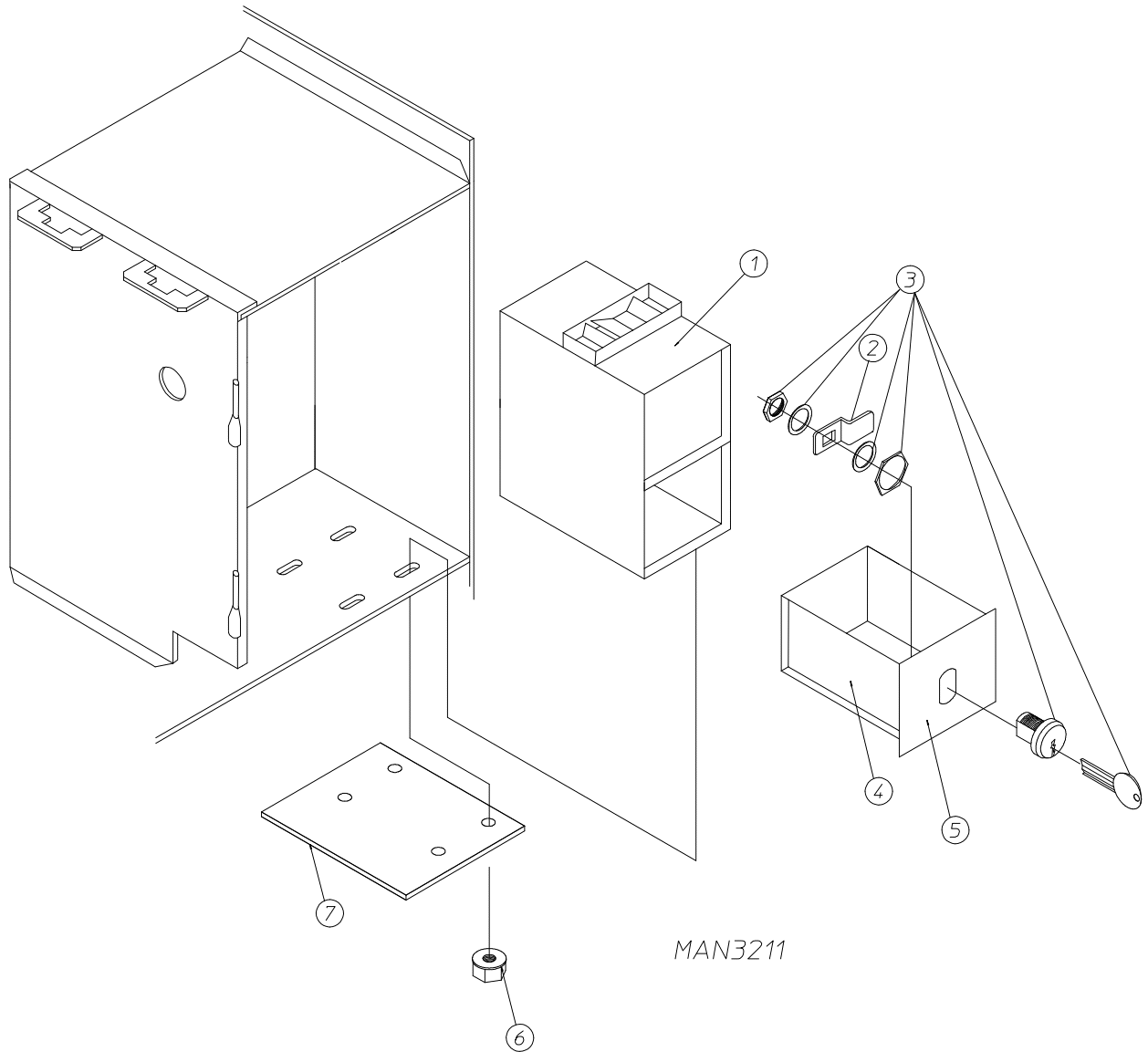

<u>Illus. No.</u>	<u>Part No.</u>	<u>Qty.</u>	<u>Description</u>
1	881431	1	Microprocessor Coin Vault Assembly Complete (includes illus. nos. 1 through 6)
	802123	1	Microprocessor Coin Vault ONLY
2	160006		Cam for 1/4 Turn Lock ONLY
3	875061	1	1/4 Turn Lock Assembly (includes illus. nos. 2 and 3)
	160007	1	1/4 Turn Lock with Key ONLY
	160105*	1	1/4 Turn Mer-Pel Key ONLY
4	802020	1	1/4 Turn Coin Box Assembly (includes illus. nos. 2 through 4)
	802019	1	1/4 Turn Coin Box ONLY Without Faceplate
5	802018	1	1/4 Turn Coin Box Faceplate ONLY
6	152014	4	1/4-20 Free Spin Wash Nut
7	309250	1	Coin Vault Slot Cover

* Specify key number when ordering.

Main Door "Steel" Assembly

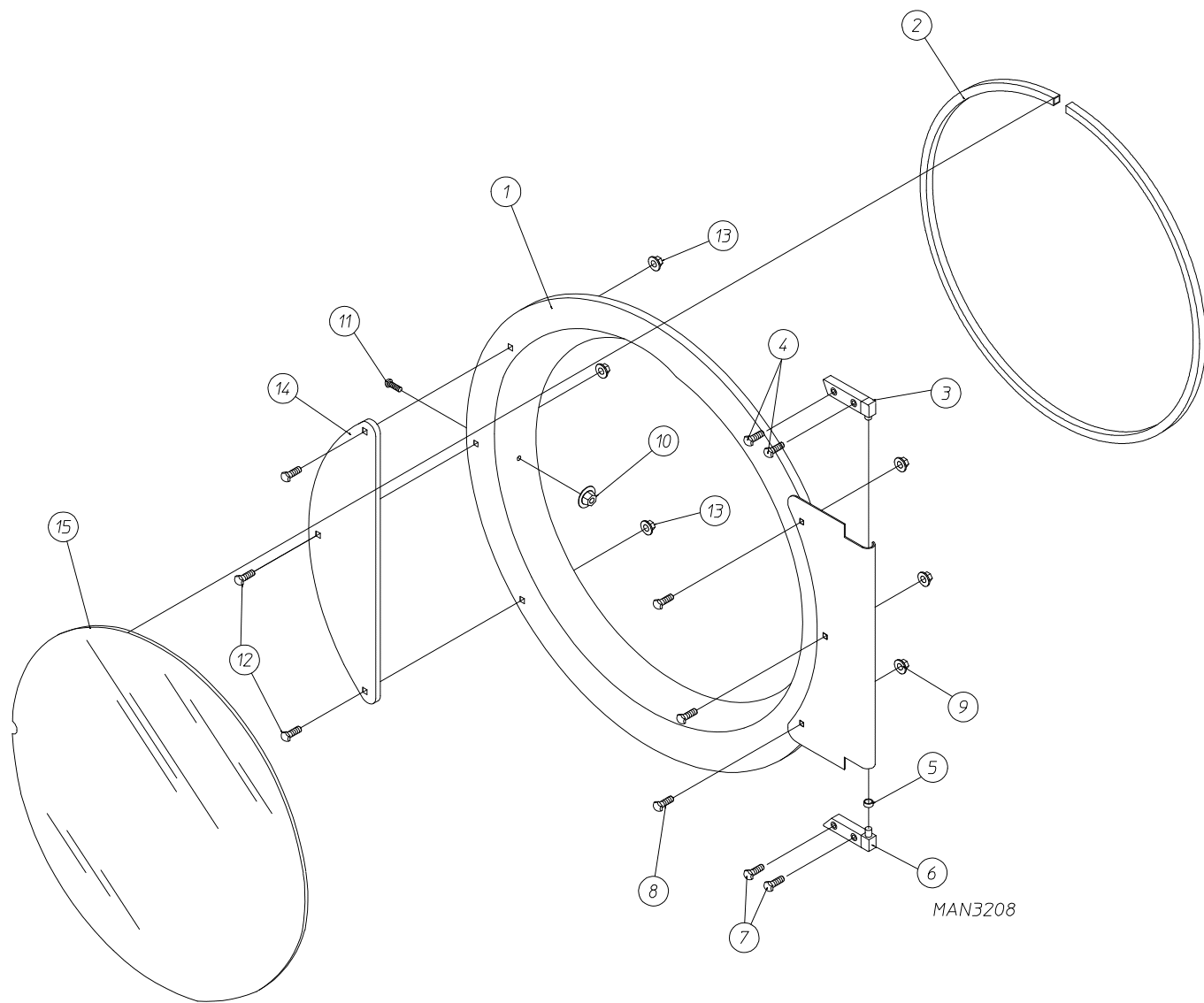

<u>Illus. No.</u>	<u>Part No.</u>	<u>Qty.</u>	<u>Description</u>
1	881150	1	Black Main Door Assembly Complete (includes illus. nos. 1, 2, and 8 through 15)
	881207	1	Stainless Steel Main Door Assembly Complete (includes illus. nos. 1, 2, and 8 through 15)
2	102349	1	Door Gasket
	170731	1	Gasket Adhesive (Black) 10.7 oz. Cartridge
	170730	1	Gasket Adhesive (Clear) 10.7 oz. Cartridge
3	881152	1	Top Hinge Block (Black) (includes illus. nos. 3 and 4)
	881208	1	Top Hinge Block (Stainless Steel) (includes illus. nos. 3 and 4)
4	150445	2	1/4-20 x 3/4" Black Cap Head Setscrew
	150443	2	1/4-20 x 3/4" Stainless Steel Cap Head Setscrew
5	153031	1	1/4" Nylon Washer
6	881151	1	Bottom Hinge Block (Black) (includes illus. nos. 5 through 7)
	881209	1	Bottom Hinge Block (Stainless Steel) (includes illus. nos. 5 through 7)
7	150445	2	1/4-20 x 3/4" Black Cap Head Setscrew
	150443	2	1/4-20 x 3/4" Stainless Steel Cap Head Setscrew
8	150683	3	Black 1/4-20 x 5/8" Carriage Bolt
	150682	3	Polished 1/4-20 x 5/8" Carriage Bolt (for models with stainless steel doors)
9	152014	3	1/2-20 Free Spin Wash Nut
10	151010	1	#10-32 Hex Acorn Nut (Black)
	151009	1	#10-32 Hex Acorn Nut (Stainless Steel)
11	150120	1	Door Latch Screw
12	150683	3	Black 1/4-20 x 5/8" Carriage Bolt
	150682	3	Polished 1/4-20 x 5/8" Carriage Bolt (for models with stainless steel doors)
13	152014	3	1/2-20 Free Spin Wash Nut
14	881210	1	Black Main Door Handle ONLY
	170333	1	Stainless Steel Main Door Handle ONLY
15	102211	1	20-9/16" Door Glass with Notch
	170731	1	Glass Adhesive (Black) 10.3 oz. Cartridge
	170730	1	Glass Adhesive (Clear) 10.3 oz. Cartridge

Insulated Front Panel Assembly

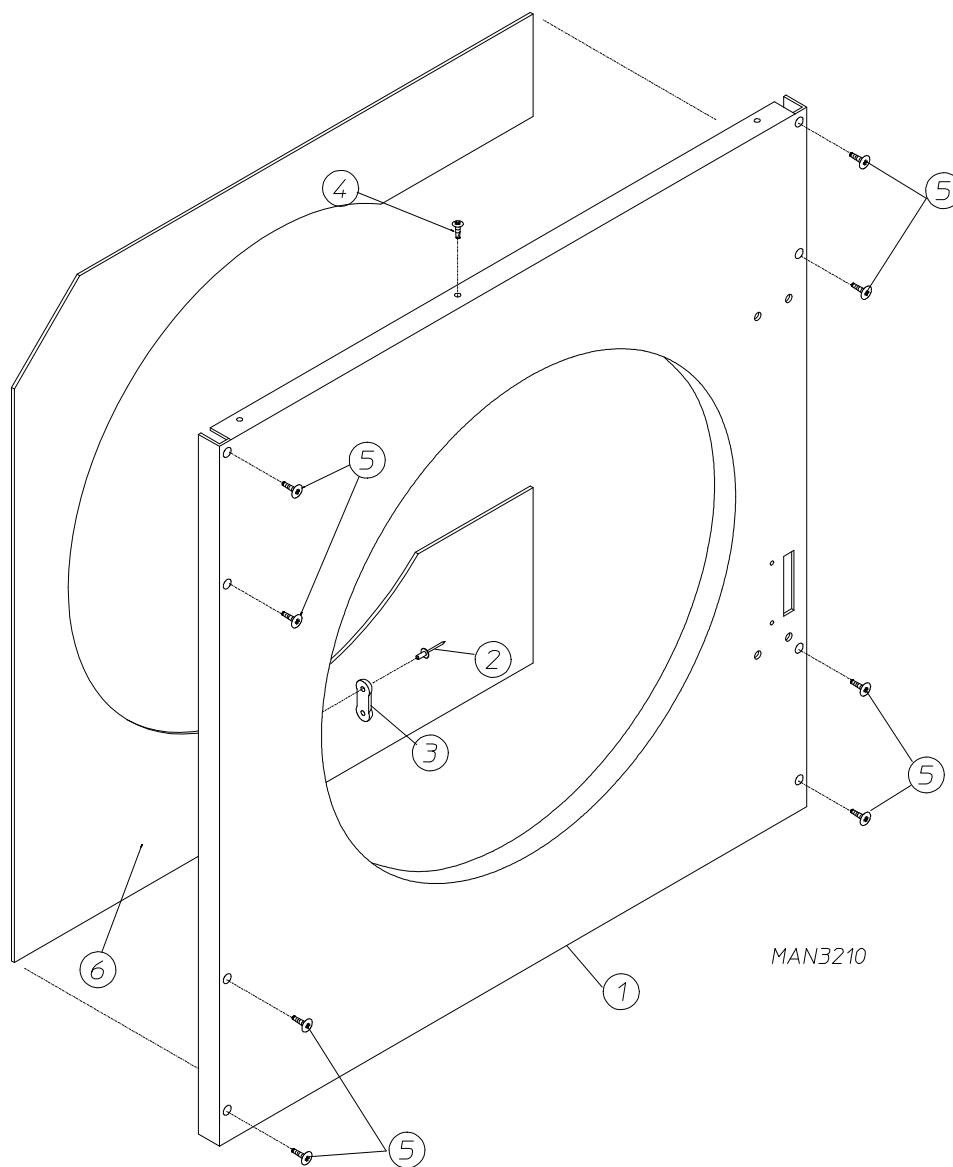

<u>Illus. No.</u>	<u>Part No.</u>	<u>Qty.</u>	<u>Description</u>
1	881510	1*	Insulated Front Panel Assembly (includes illus. nos. 1 through 3 and 6)
	881509	1*	Textured and Insulated Front Panel Assembly (includes illus. nos. 1 through 3 and 6)
2	154215	2	5/32" Pop Rivet
3	170330	1	Friction Door Latch
4	150300	1	#10 x 1/2" Hex Washer TEK Screw
5	150415	8	#10-16 x 1/2" Phillips Round Head Screw
6	116526	1	Front Panel Insulation

* Specify color when ordering.

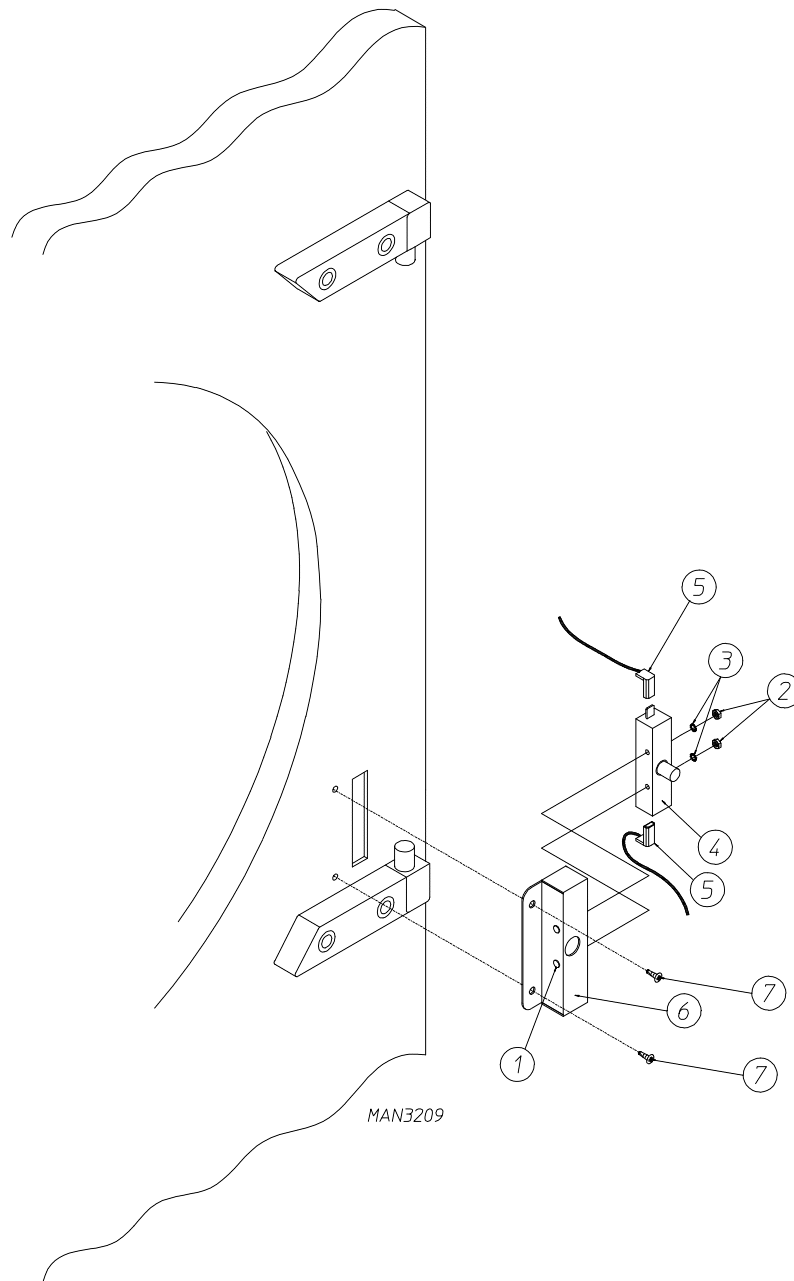

<u>Illus. No.</u>	<u>Part No.</u>	<u>Qty.</u>	<u>Description</u>
1	153565	2	#6-32 x 1" Clinch Stud
2	152013	2	#6-32 Hex Nut
3	153010	2	#6 Star Washer
4	137005	1	Door Switch
5	122636	2	Flag Terminal
6	881211	1	Black Main Door Switch Housing ONLY
	881153	1	Black Main Door Switch Housing Complete (includes illus. nos. 1 through 4 and 6)
7	150301	2	#8 x 7/16" Phillips Head TEK Screw

Drop Lint Door Assembly

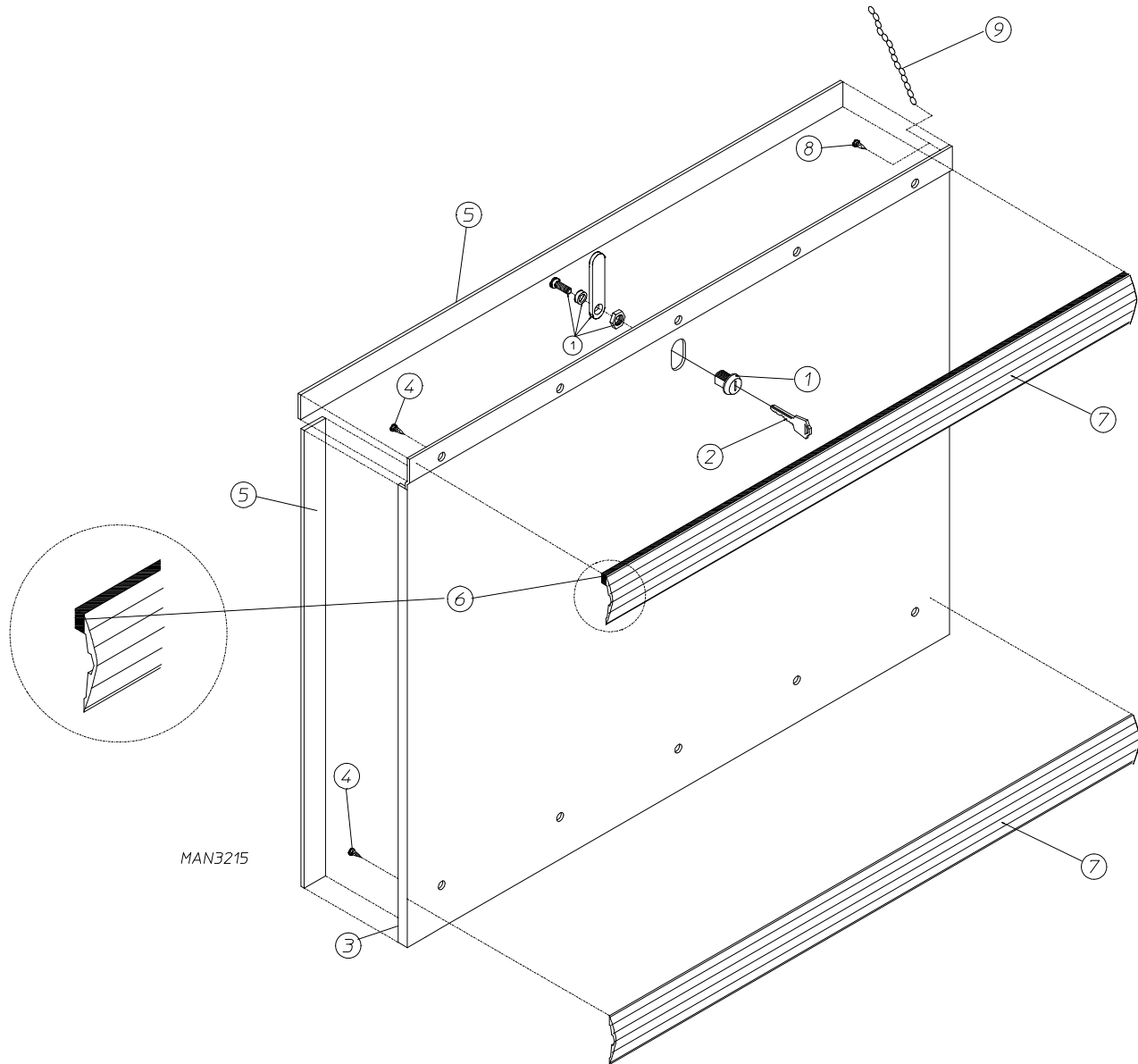

<u>Illus. No.</u>	<u>Part No.</u>	<u>Qty.</u>	<u>Description</u>
1	160039	1	Lint Door Lock
2	160140	1	Key ONLY for XX4451 Lock
3	881436*	1	Insulated Drop Lint Door Assembly Complete (includes illus. nos. 3 through 7)
	881437*	1	Insulated Textured Drop Lint Door Assembly Complete (includes illus. nos. 3 through 7)
4	150201	10	#10-32 x 1/4" Phillips Pan Head TEK Screw
5	117600	7	Noise Suppressor Tape (sold by the foot)
6	117603	5	Suppressor Tape / Gasket (sold by the foot)
7	180313	2	Black Trim
8	150419	2	#6 x 1/2" Tamperproof TEK Screw
-	150418	1	Tamperproof Screw Hand Driver
9	108120	1	Chain for Drop Lint Door (10-1/2" length)

* Specify color when ordering.

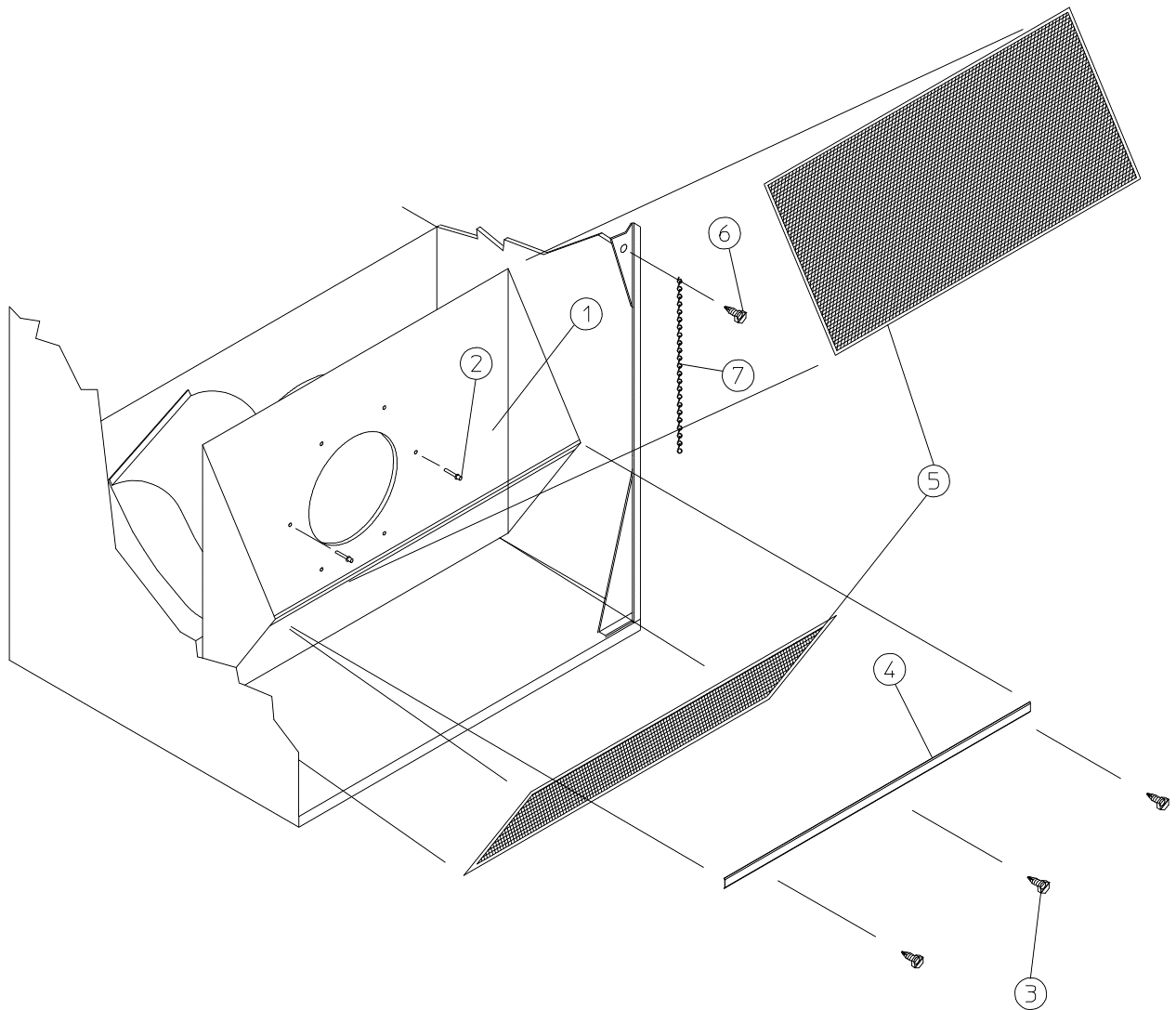

MAN0275

<u>Illus. No.</u>	<u>Part No.</u>	<u>Qty.</u>	<u>Description</u>
1	881432	1	Lint Trap ONLY
	881433	1	Lint Trap Assembly Complete (includes illus. nos. 1 through 5)
2	154200	7	5/32" Pop Rivet
3	150300	3	#10 x 1/2" Hex Washer TEK Screw
4	304100	1	Lint Trap Screen Hold Down
5	800500	2	Lint Screen
6	150419	2	#6 x 1/2" Tamperproof Screw
-	150418	1	Tamperproof Screw Hand Driver
7	108120	1	Chain for Drop Lint Door (10-1/2" length)

Tumbler / Support Assemblies

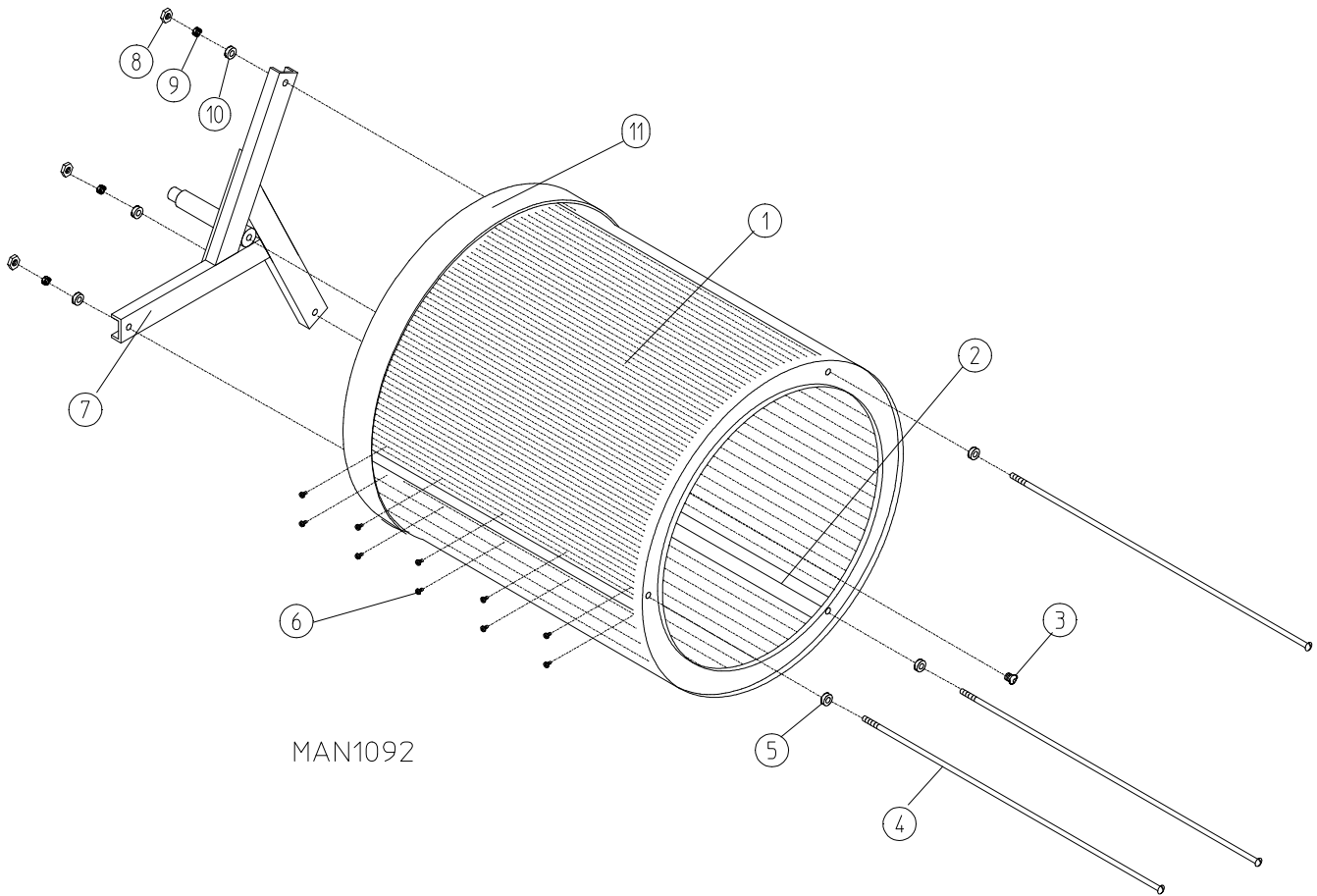

<u>Illus. No.</u>	<u>Part No.</u>	<u>Qty.</u>	<u>Description</u>
1	800830	1	AD-385 Basket and Support Assembly Complete with Felt Collars (includes illus. nos. 1 through 11)
	800890		Complete with Felt Collar (includes illus. nos. 1 through 11)
	800720*	1	AD-385 Basket Only without Felt Collars (includes illus. nos. 1, 2, and 6)
	800840*	1	AD-385 Stainless Steel Basket ONLY without Felt Collar (includes illus. nos. 1, 2, and 6)
2	301315	2	AD-385 (Short) Basket Rib ONLY
	301316	1	AD-385 (Tall) Basket Rib ONLY
	301414	2	AD-385 Stainless Steel (Short) Basket Rib ONLY
	301415	1	AD-385 Stainless Steel (Tall) Basket Rib ONLY
3	150518	1	5/16-18 x 3/8" Socket Button Head Screw
4	882050	3	5/16-18 x 31" Tie Rod
5	153001	3	5/16" Flat Washer
6	150313	30	#10-16 x 1/2" TORX® PLUS BTN Type 1
7	800612	1	AD-385 Tumbler Support ONLY
8	152004	3	5/16-18 Hex Nut
9	153002	3	5/16" Lock Washer
10	153001	3	5/16" Flat Washer
11	116003	1	Felt Collar ONLY
—	401010	1	#847 Adhesive for Felt Collar (5 oz. Tube)

* Felt collar not included and must be ordered separately.

Tumbler Bearing Assembly

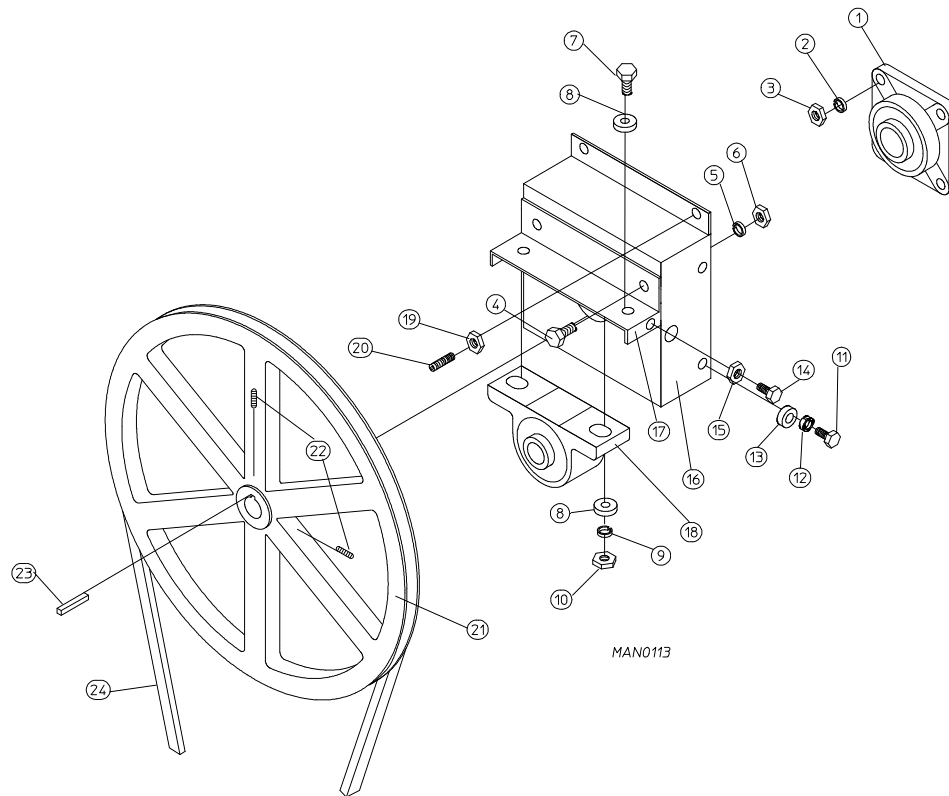

<u>Illus. No.</u>	<u>Part No.</u>	<u>Qty.</u>	<u>Description</u>
1	880203	1	1-3/8" Flange Bearing
2	153005	4	3/8" Lock Washer
3	152005	4	3/8-16 Hex Nut
4	150508	2	3/8-16 x 3/4" Hex Head Machine Bolt
5	153005	2	3/8" Lock Washer
6	152005	2	3/8-16 Hex Nut
7	150600	2	3/8-16 x 1/2" Hex Head Machine Bolt
8	153004	2*	3/8" Flat Washer
9	153005	2	3/8" Lock Washer
10	152005	2	3/8-16 Hex Nut
11	150501	4	5/16-18 x 3/4" Hex Head Machine Bolt
12	153002	4	5/16" Lock Washer
13	153001	4	5/16" Flat Washer
14	150621	2	5/16-18 x 1-1/2" Hex Head Machine Bolt
15	152004	2	5/16-18 Hex Nut
16	801101	1	1-3/8" Bearing Box Assembly Complete (for models mfd. without Rotational Sensor) (includes illus. nos. 4 through 20)
	801103	1	1-3/8" Bearing Box and Support Assembly ONLY (includes illus. nos. 4 through 6, 16, and 17)
	801105	1	1-3/8" Bearing Box ONLY
17	801104	1	1-3/8" Pillow Block Bearing Support ONLY
18	880202	1	1-3/8" Pillow Block Bearing ONLY
19	152004	2	5/16-18 Hex Nut
20	150610	2	5/16-18 x 1-1/2" Allen Setscrew
21	101100	1	18" Pulley
22	154301	2	5/16-18 x 5/16" Allen Setscrew
23	100713	1	1/4" x 1/4" x 7/8" Key
24	100189	1	5L640 "V" Belt (to idler assembly) (for models mfd. as of April 16, 1999)
	100111	1	5L650 "V" Belt (to idler assembly) (for models mfd. prior to April 16, 1999)

* Some models require a quantity of 4.

Idler Bearing Assembly

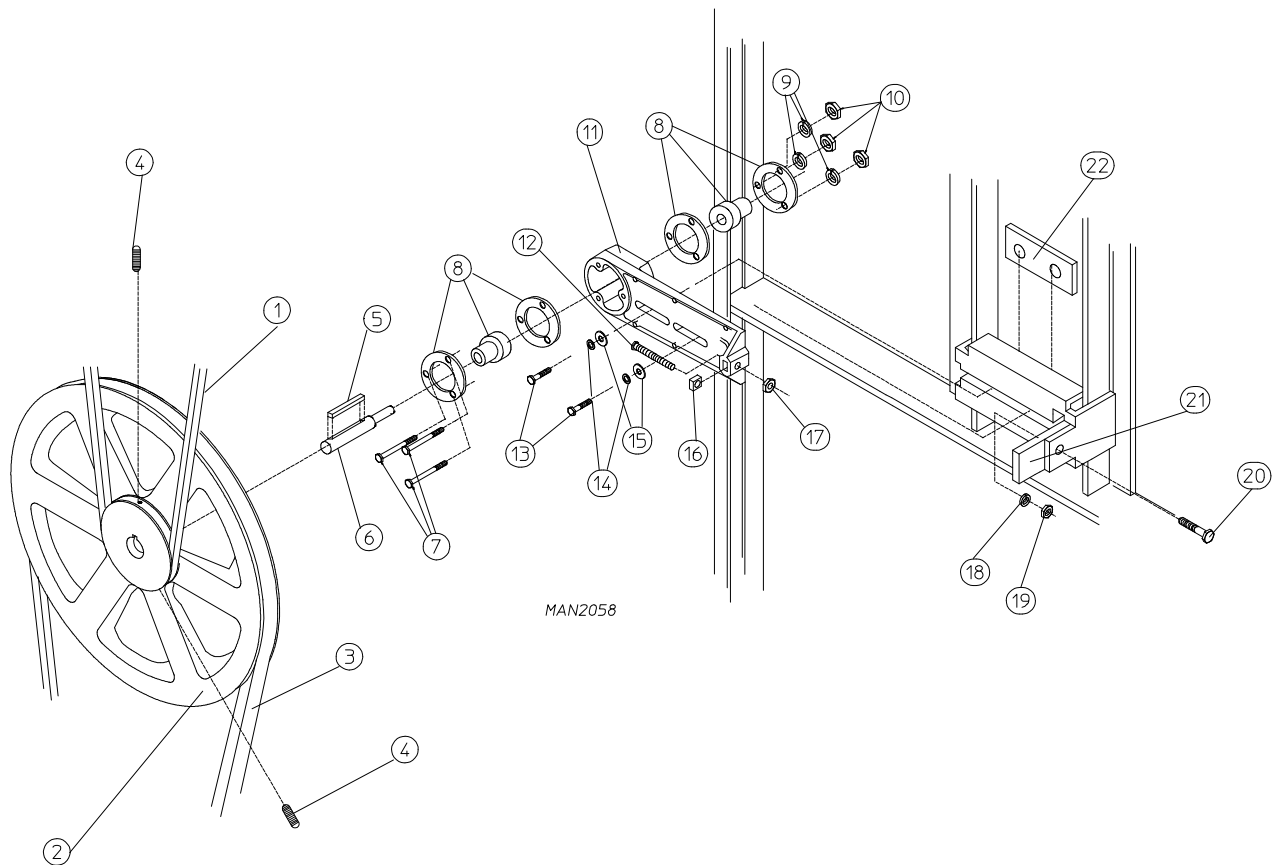

<u>Illus. No.</u>	<u>Part No.</u>	<u>Qty.</u>	<u>Description</u>
1	100189	1	5L640 "V" Belt (tumbler to idler) (for models mfd. as of April 16, 1999)
	100111	1	5L650 "V" Belt (tumbler to idler) (for models mfd. prior to April 16, 1999)
2	101129	1	9" x 2-1/2" Compound Pulley ONLY
3	100101	1	4L480 "V" Belt (idler to motor)
4	154301	4	5/16-18 x 1" Cone Point Setscrew
5	100705	1	3/16" x 3/16" x 1-3/8" Key
6	301850	1	5/8" x 3/4" Idler Shaft ONLY
7	150529	3	1/4-20 x 2-1/4" Carriage Bolt
8	100214	2	5/8" Flange Bearing (with flanges) ONLY
9	153007	3	1/4" Lock Washer
10	152002	3	1/4-20 Hex Nut
11	801008	1	Idler Bearing Assembly Complete (includes illus. nos. 6 through 22)
	100406	1	Idler Bearing Mount ONLY
12	150613	1	5/16-18 x 4" Hex Head Machine Bolt
13	150617	2	3/8-16 x 1" Hex Head Machine Bolt
14	153005	2	3/8" Lock Washer
15	153004	2	3/8" Flat Washer
16	152020	1	5/16-18 Standard Square Nut
17	152004	1	5/16-18 Hex Nut
18	152005	1	3/8-16 Hex Nut
19	153005	1	3/8" Lock Washer
20	150617	1	3/8-16 x 1" Hex Head Machine Bolt
21	301851	1	Idler Bracket Adjustment Plate
22	801009	1	Idler Square Washer

Totally Enclosed, Fan-Cooled (T.E.F.C.) Motor Mount Assembly

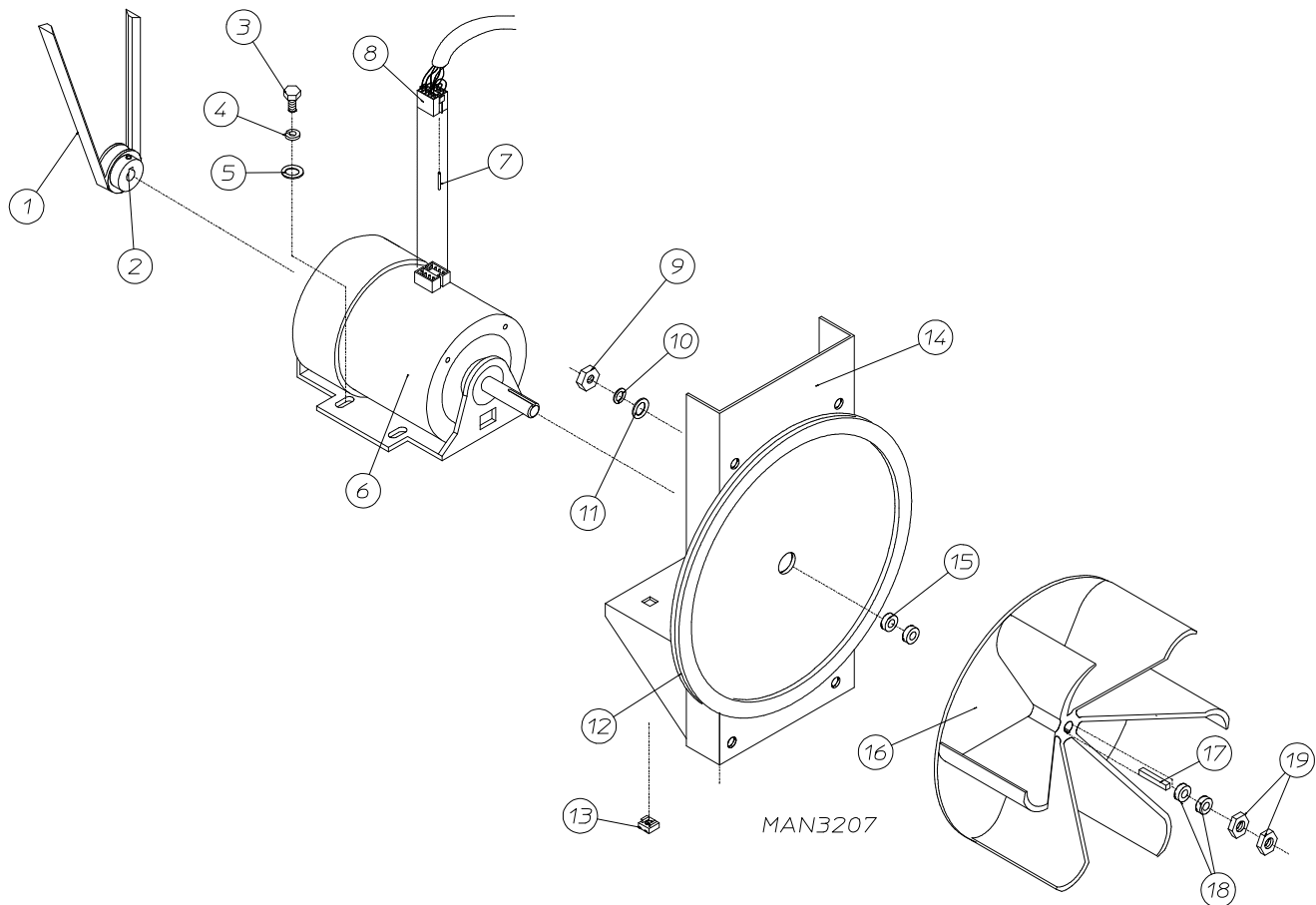

<u>Illus. No.</u>	<u>Part No.</u>	<u>Qty.</u>	<u>Description</u>
1	100101	1	4L480 "V" Belt (to idler assembly)
2	101133	1	5/8" x 2-1/4" Sheave (for use on 1Ø – 60 Hz Motors ONLY)
3	150501	4	5/16-18 x 3/4" Hex Head Machine Bolt
4	153002	4	5/16" Lock Washer
5	153001	4	5/16" Flat Washer
6	100073	1	1 hp 115/230v 60 Hz 1Ø T.E.F.C. Plug-Type Motor
7	122701	8	Socket Terminal ONLY
	122801	1	Pin / Socket Extraction Tool
8	137030	1	8-Pin Housing Connector
9	152004	4	5/16-18 Hex Nut
10	153002	4	5/16" Lock Washer
11	153001	4	5/16" Flat Washer
12	117600	4	Noise Suppressor Tape (sold by the foot)
13	154000	4	5/16-18 Tinnerman Nut
14	800911	1	1 hp Motor Mount ONLY
	881661	1	1 hp 120-230V 1Ø 60 Hz Motor Mount Assembly Complete (includes illus. nos. 2 through 12 and 19)
15	153050	2	1/2" S.A.E. Flat Washer
16	100603	1	16" Impellor (fan / blower) with 3/4" Bore
17	100702	1	1/8" x 1/8" x 1-1/2" Key
18	153050	2	1/2" S.A.E. Flat Washer
19	152006	2	1/2-20 Left-Hand Jam Nut

Sensor Bracket Assemblies

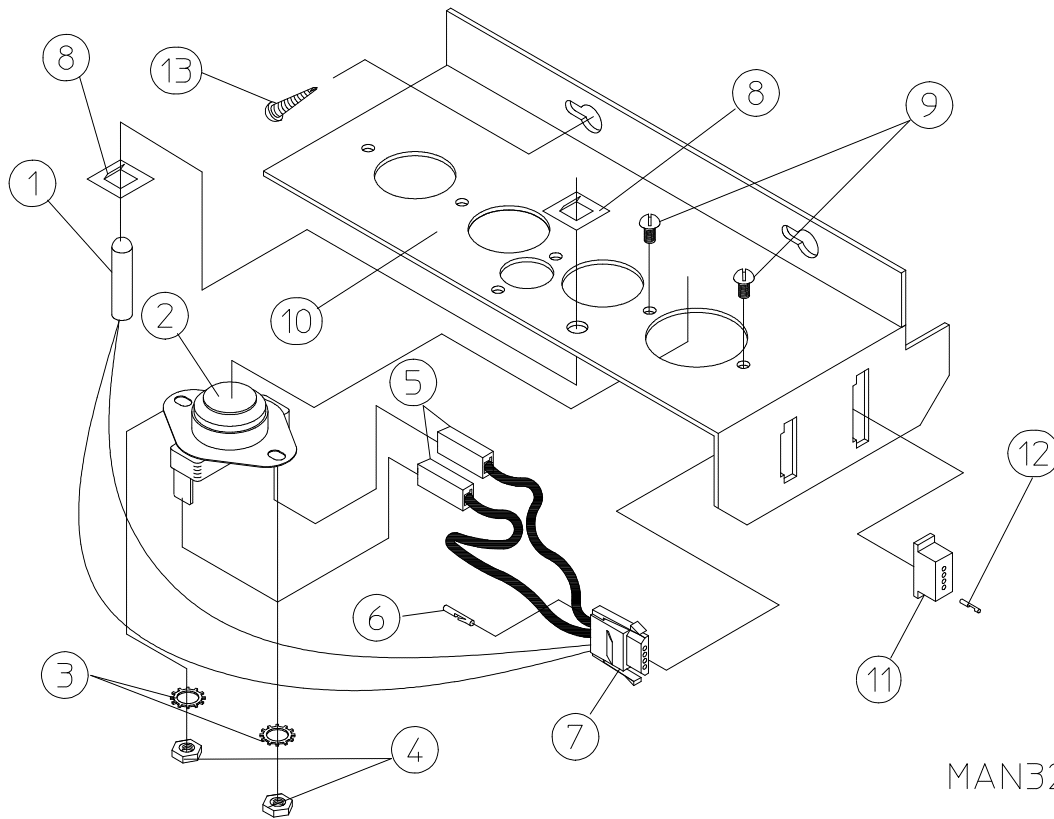

MAN3281

MICROPROCESSOR SENSOR BRACKET ASSEMBLY

<u>Illus. No.</u>	<u>Part No.</u>	<u>Qty.</u>	<u>Description</u>
1	880251	1	1/4" Temperature Sensor Probe Assembly (includes illus. nos. 1 and 5 through 8)
2	130103	1	225° Large Automatic Thermostat
3	153010	2	#6 Star Washer
4	152000	2	#6-32 Hex Nut
5	121028	2	Insulated Terminal ONLY
6	122701	4	Socket Terminal ONLY
7	122605	1	4-Pin Socket ONLY
8	154007	2	1/4" Tinnerman Push-On Fastener
9	150005	2	#6-32 x 1/4" Round Head Machine Screw
10	801425	1	Microprocessor Sensor Bracket Assembly Complete (includes illus. nos. 1 through 10)
	305007	1	Universal Sensor Bracket ONLY
11	122604	1	4-Pin Connector ONLY
	122700	4	Pin Terminal ONLY
	150301	2	#8-18 x 7/16" Phillips Pan Head TEK Screw

Direct Spark Ignition Burner Assembly

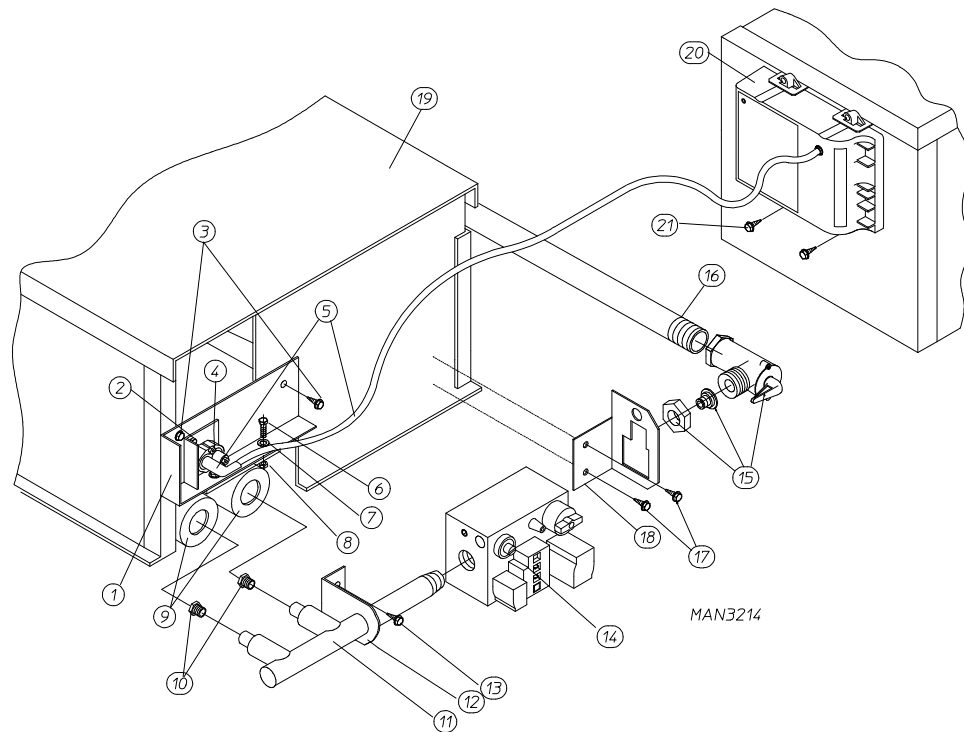

<u>Illus. No.</u>	<u>Part No.</u>	<u>Qty.</u>	<u>Description</u>
1	318030	1	DSI Burner Shield ONLY
2	150300	2	#10 x 1/2" Hex Washer TEK Screw
3	150415	2	#10-16 x 1/2" Phillips Round Head CrimpTite Screw
4	880134	1	DSI Ignitor / Flame-Probe Assembly Kit (includes high voltage wire and connector)
	305410	1	DSI Ignitor Gap Feeler Gauge ... Not Illustrated
5	880330	1	DSI Ignitor High Voltage Wire / Connector ONLY
6	150103	2	#8-32 x 3/4" Pan Head Machine Screw
7	153000	2	#8 Steel Burr
8	151001	2	#8-32 Pal Nut
9	141105	2	Large Gas "T" Burner
10**	140822	2	#27 Burner Orifice (natural gas) ONLY
	140808	2	#44 Burner Orifice (liquid propane) ONLY
11	141230	1	1/2" 2-Port DSI Manifold
12	318700	1	Pipe Bracket (bent)
13	150300	2	#10 x 1/2" Hex Washer TEK Screw
14	128927	1	1/2" 24 VAC Redundant (natural gas) Gas Valve
	140411	1	1/2" 24 VAC Gas Valve Liquid Propane Conversion Kit
	880960	1	1/2" DSI Liquid Propane Gas Valve Assembly
15	141313	1	90° 1/2" x 1" Gas Shutoff Assembly
16	142809	1	1/2" x 29-1/8" Pipe
17	150309	2	#10-16 x 1/2" Phillips Hex Head TEK CrimpTite Screw
18	318712	1	Pipe Bracket
19	850858	1	Burner Box ONLY
	881607*	1	AD-385 DSI (Natural) Burner Assembly Complete Less Orifice (includes illus. nos. 1 through 9 and 11 through 19)
	881608*	1	AD-385 DSI (Liquid Propane) Burner Assembly Complete Less Orifice (includes illus. nos. 1 through 9 and 11 through 19)
20	880815	1	DSI Module Only (50/60 Hz)
21	150299	4	#10 x 1" Hex Washer TEK Screw
—	881478**	1	Dryer Liquid Propane Conversion Kit ... Not Illustrated

* Burner orifices are not included and must be ordered separately.

** Consult factory for elevations over 2,000 feet.

ADG-385 Sail Switch / Hi-Limit Assembly

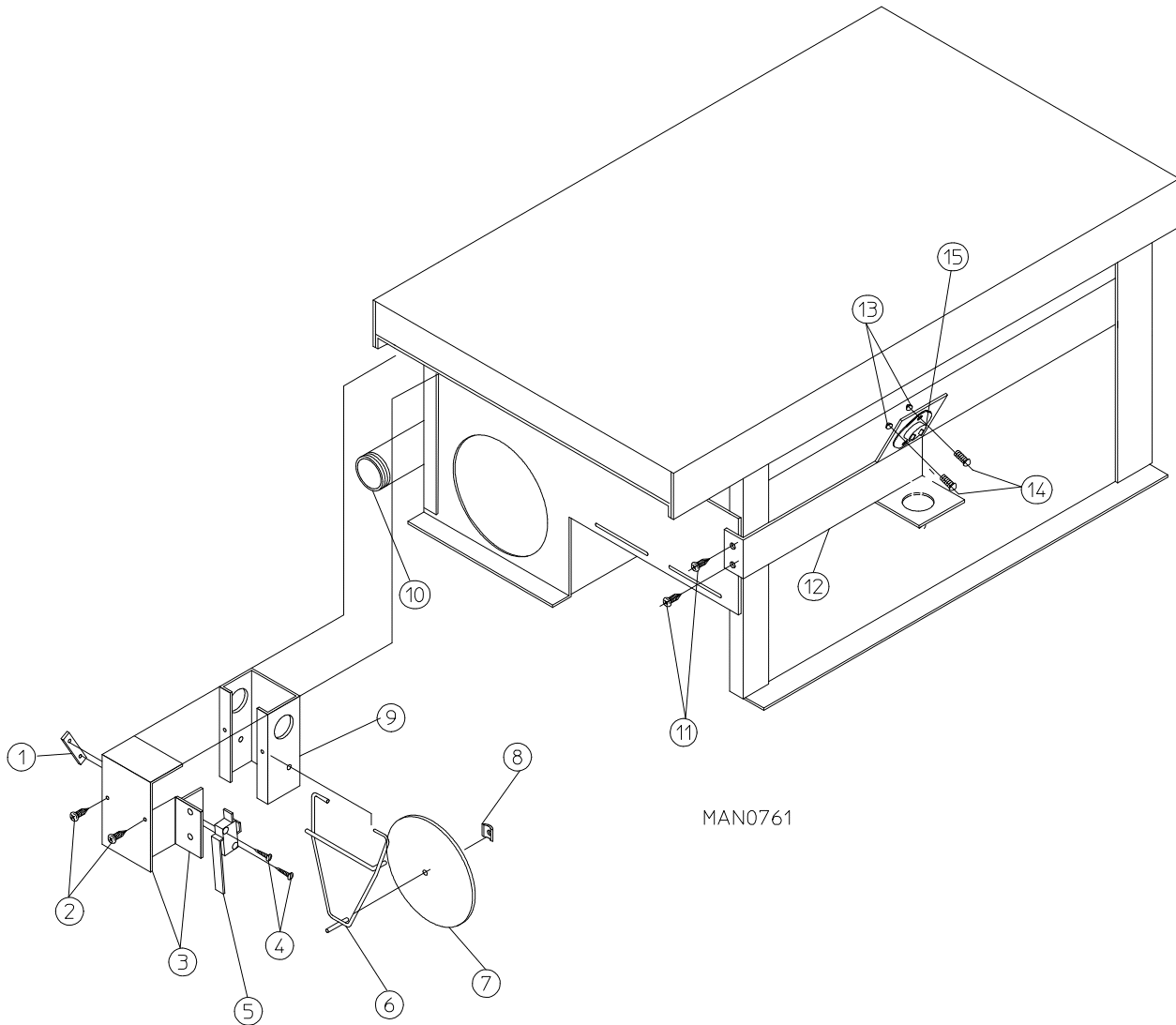

<u>Illus. No.</u>	<u>Part No.</u>	<u>Qty.</u>	<u>Description</u>
1	154004	1	Twin Speed Nut
2	150415	2	#10-16 x 1/2" Phillips Round Head Crimptite Screw
3	802799	1	Sail Switch Box Cover and Bracket ONLY
4	150303	2	#4 x 3/4" Pan Head "A" Machine Screw
5	122200	1	Sail Switch ONLY
6	105500	1	Sail Switch Actuator Rod
7	319202	1	Sail Switch Damper (flat)
8	154002	1	1/8" Push-On Fastener
9	802800	1	Sail Switch Box With Cover and Bracket ONLY
	802801	1	Sail Switch Box Assembly Complete (includes illus. nos. 1 through 8)
10	142809	1	1/2" x 29-1/8" Pipe
11	150415	2	#10-16 x 1/2" Phillips Round Head Crimptite Screw
12	319704	1	Hi-Limit Mounting Bracket ONLY
13	151000	2	#6-32 Pal Nut
14	150001	2	#6-32 x 1/2" Round Head Machine Screw
15	130401	1	330° Hi-Limit

Single Phase Motor, Electric Relay Panel Assembly

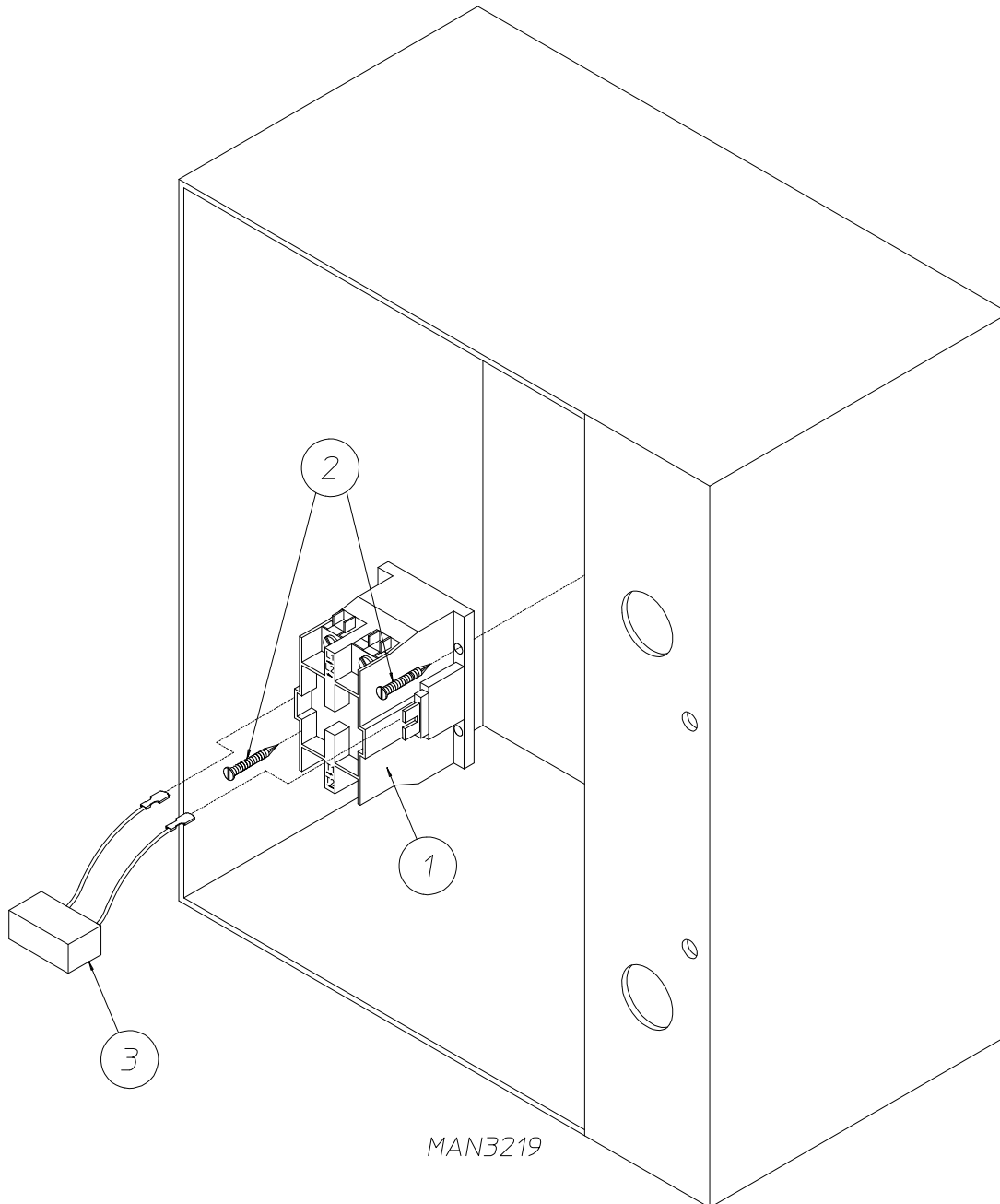

<u>Illus. No.</u>	<u>Part No.</u>	<u>Qty.</u>	<u>Description</u>
1	132451	1	2-Pole Contactor – 24 VAC
2	150299	2	#10 x 1" Hex Head Screw
3	824828	1	RC Network with Connectors (for Microprocessor Models ONLY)
	322809	1	Back Electrical Box Cover ... Not Illustrated
	150301	5	#8-18 x 7/16" Phillips Pan Head TEK Screw ... Not Illustrated

Outer Top / Back Guard Assembly

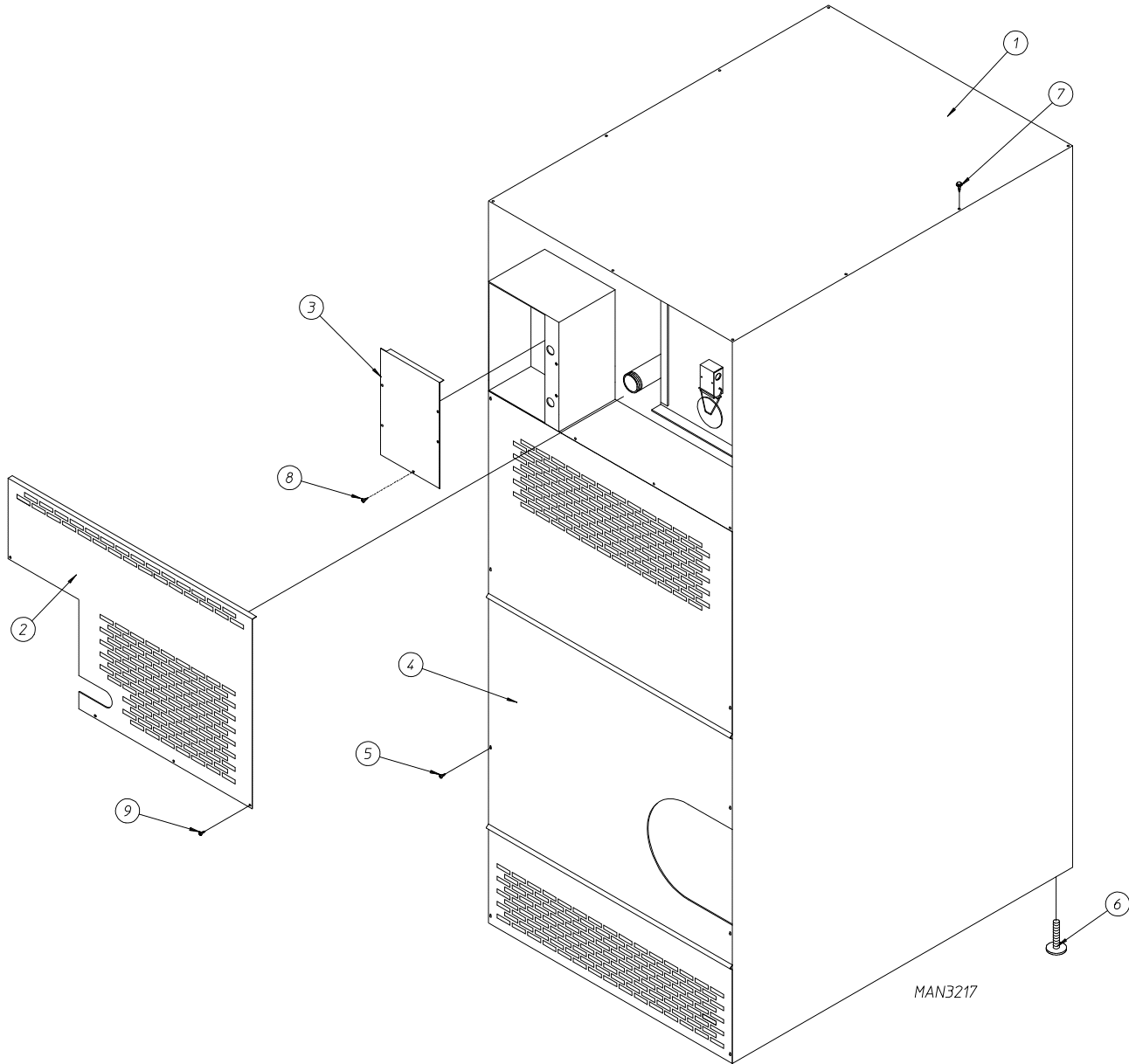

<u>Illus. No.</u>	<u>Part No.</u>	<u>Qty.</u>	<u>Description</u>
1	330605	1	Outer Top
2	330606	1	Top Back Guard Assembly
3	322809	1	Back Electrical Box Cover
4	330604	1	Lower Back Guard Assembly
5	150301	10	#8-18 x 7/16" Phillips Pan Head TEK Screw
6	103500	4	Leveling Leg
7	150300	9	#10 x 1/2" Hex Washer TEK Screw
8	150301	5	#8-18 x 7/16" Phillips Pan Head TEK Screw
9	150301	7	#8-18 x 7/16" Phillips Pan Head TEK Screw

NOTE: Coin acceptors listed include optical switch (ADC Part No. 137056).

Single Coin*

<u>ADC Part No.</u>	<u>Nation</u>	<u>Description</u>
125100	United States and Canada	25¢ Optic Coin Acceptor
125114	United Kingdom	20 New Pence Optic Coin Acceptor
125102	Belgium	5 Belgian Franc Optic Coin Acceptor
125120	France	2 French Franc Optic Coin Acceptor
125124	France	5 French Franc Optic Coin Acceptor
125137	Denmark	New 1 Danish Krone Optic Coin Acceptor
125140	Denmark	New 2 Danish Krone Optic Coin Acceptor
125107	Australia	20¢ Australian Optic Coin Acceptor
125130	Australia	\$1 Australian Optic Coin Acceptor
125123	New Zealand	50¢ New Zealand Optic Coin Acceptor
125132	Singapore	50¢ Singapore Optic Coin Acceptor
125104	Japan	100 Yen Optic Coin Acceptor
125133	Hong Kong	\$1 Hong Kong Optic Coin Acceptor
125103	—	.882 Token Optic Coin Acceptor
125121	—	.800 Token Optic Coin Acceptor
125129	—	Muller Token Optic Coin Acceptor

Dual Coin*

<u>ADC Part No.</u>	<u>Nation</u>	<u>Description</u>
125128	Canada	25¢/\$1 Dual Optic Coin Acceptor
125113	United Kingdom	1£/20 Pence Dual Optic Coin Acceptor
125119	Belgium	5/20 Belgian Franc Dual Optic Coin Acceptor
125122	France	2/5 French Franc Dual Optic Coin Acceptor
125134	Denmark	New 1/5 Danish Krone Dual Optic Coin Acceptor
125139	Denmark	New 2/5 Danish Krone Dual Optic Coin Acceptor
125126	Netherlands	25/1 Dutch Guilder Dual Optic Coin Acceptor

* Consult factory for coin acceptors not listed.

ADG-385 Step Down Transformer Usage Listing

ADG-385	Voltage	Wire Service	Step Down Transformer P/N
	208/240	3 or 4	—
	380	3	132059
	380	4	132059
	416	3	132062
	416	4	132062
	460/480	3	132053
	460/480	4	132053
	575	3	132050

NOTE: Step Down Transformer used on models mfd. for 380 volts or higher.

<u>Part No.</u>	<u>Description</u>
112027	“Water Washed Fabrics” Label
112040	“Lint Compartment” Label
112041	“Caution-Exhausted” Label
112533	Phase 5 Coin “Program Location Summary” Label
112534	Phase 5 Non-Coin “Program Location Summary” Label
120100	3/8” Straight (BX) Connector
120300	3/8” x 45° (BX) Connector
120400	3/8” Red Jacket (BX) Insulator
120500	3/8” Jiffy Clip (BX Retainer Clip)
120600	3/8” Greenfield (BX)
120707	Terminal Strip (2-position)
120708	Terminal Strip (3-position)
120800	1/4” In-Line Connector
120802	Red Butt Connector
120902	#74B Wire Nut
120903	Crimp-On Wire Nut
121014	1/4” Insulated (female) Terminal
121026	Tab Receptacle Combination
121499	4” Harness Tie
121500	8” Harness Tie
121503	Harness Tie Mounting Clip
122804	Manometer (water column test gauge)
404500	Almond Brush-In-Cap Bottle Touch-Up Paint
404502	White Brush-In-Cap Bottle Touch-Up
404506	Beige Brush-In-Cap Bottle Touch-Up Paint
404507	Cornflower Blue Brush-In-Cap Bottle Touch-Up Paint
880200	Electrical Terminal (assortment) Kit

